

**OMRON**

Overview

CompoWay/F

Com Data for  
CompoWay/F

SYSTEMWAY

Modbus

Com Data  
for Modbus

Appendix

**E5CN**

**E5AN**

**E5EN**

**E5GN**

# Digital Temperature Controllers

## Communications Manual Basic Type

Cat. No. H158-E1-02



# Preface

---

Serial communications can be performed with the E5CN, E5AN, E5EN, and E5GN.

This manual describes the communications capabilities supported by the E5CN, E5AN, E5EN, and E5GN. Read and understand this manual before using communications with the E5CN, E5AN, E5EN, or E5GN and be sure you are performing communications correctly.

Keep this manual in a safe location where it will be available when needed.

For information on the communications functions of the Advanced Type E5CN-H, E5AN-H, and E5EN-H Digital Temperature Controllers, refer to the Communications Manual provided for Advanced Type models (Cat. No. H159).

**© OMRON, 2008**

All rights reserved. No part of this publication may be reproduced, stored in a retrieval system or transmitted, in any form, or by any means, mechanical, electronic, photocopying, recording, or otherwise, without the prior written permission of OMRON.

No patent liability is assumed with respect to the use of the information contained herein. Moreover, because OMRON is constantly striving to improve its high-quality products, the information contained in this manual is subject to change without notice. Every precaution has been taken in the preparation of this manual. Nevertheless, OMRON assumes no responsibility for errors or omissions. Neither is any liability assumed for damages resulting from the use of the information contained in this publication.

## Read and Understand this Manual

Please read and understand this manual before using the products. Please consult your OMRON representative if you have any questions or comments.

## Warranty, Limitations of Liability

### WARRANTY

OMRON's exclusive warranty is that the products are free from defects in materials and workmanship for a period of one year (or other period if specified) from date of sale by OMRON.

OMRON MAKES NO WARRANTY OR REPRESENTATION, EXPRESS OR IMPLIED, REGARDING NON-INFRINGEMENT, MERCHANTABILITY, OR FITNESS FOR PARTICULAR PURPOSE OF THE PRODUCTS. ANY BUYER OR USER ACKNOWLEDGES THAT THE BUYER OR USER ALONE HAS DETERMINED THAT THE PRODUCTS WILL SUITABLY MEET THE REQUIREMENTS OF THEIR INTENDED USE. OMRON DISCLAIMS ALL OTHER WARRANTIES, EXPRESS OR IMPLIED.

### LIMITATIONS OF LIABILITY

OMRON SHALL NOT BE RESPONSIBLE FOR SPECIAL, INDIRECT, OR CONSEQUENTIAL DAMAGES, LOSS OF PROFITS OR COMMERCIAL LOSS IN ANY WAY CONNECTED WITH THE PRODUCTS, WHETHER SUCH CLAIM IS BASED ON CONTRACT, WARRANTY, NEGLIGENCE, OR STRICT LIABILITY.

In no event shall the responsibility of OMRON for any act exceed the individual price of the product on which liability is asserted.

IN NO EVENT SHALL OMRON BE RESPONSIBLE FOR WARRANTY, REPAIR, OR OTHER CLAIMS REGARDING THE PRODUCTS UNLESS OMRON'S ANALYSIS CONFIRMS THAT THE PRODUCTS WERE PROPERLY HANDLED, STORED, INSTALLED, AND MAINTAINED AND NOT SUBJECT TO CONTAMINATION, ABUSE, MISUSE, OR INAPPROPRIATE MODIFICATION OR REPAIR.

## Application Considerations

### SUITABILITY FOR USE

OMRON shall not be responsible for conformity with any standards, codes, or regulations that apply to the combination of the products in the customer's application or use of the products.

At the customer's request, OMRON will provide applicable third party certification documents identifying ratings and limitations of use that apply to the products. This information by itself is not sufficient for a complete determination of the suitability of the products in combination with the end product, machine, system, or other application or use.

The following are some examples of applications for which particular attention must be given. This is not intended to be an exhaustive list of all possible uses of the products, nor is it intended to imply that the uses listed may be suitable for the products:

- Outdoor use, uses involving potential chemical contamination or electrical interference, or conditions or uses not described in this manual.
- Nuclear energy control systems, combustion systems, railroad systems, aviation systems, medical equipment, amusement machines, vehicles, safety equipment, and installations subject to separate industry or government regulations.
- Systems, machines, and equipment that could present a risk to life or property.

Please know and observe all prohibitions of use applicable to the products.

NEVER USE THE PRODUCTS FOR AN APPLICATION INVOLVING SERIOUS RISK TO LIFE OR PROPERTY WITHOUT ENSURING THAT THE SYSTEM AS A WHOLE HAS BEEN DESIGNED TO ADDRESS THE RISKS, AND THAT THE OMRON PRODUCTS ARE PROPERLY RATED AND INSTALLED FOR THE INTENDED USE WITHIN THE OVERALL EQUIPMENT OR SYSTEM.

### PROGRAMMABLE PRODUCTS

OMRON shall not be responsible for the user's programming of a programmable product, or any consequence thereof.

## Disclaimers

### **CHANGE IN SPECIFICATIONS**

Product specifications and accessories may be changed at any time based on improvements and other reasons.

It is our practice to change model numbers when published ratings or features are changed, or when significant construction changes are made. However, some specifications of the products may be changed without any notice. When in doubt, special model numbers may be assigned to fix or establish key specifications for your application on your request. Please consult with your OMRON representative at any time to confirm actual specifications of purchased products.

### **DIMENSIONS AND WEIGHTS**

Dimensions and weights are nominal and are not to be used for manufacturing purposes, even when tolerances are shown.

### **PERFORMANCE DATA**

Performance data given in this manual is provided as a guide for the user in determining suitability and does not constitute a warranty. It may represent the result of OMRON's test conditions, and the users must correlate it to actual application requirements. Actual performance is subject to the OMRON Warranty and Limitations of Liability.

### **ERRORS AND OMISSIONS**

The information in this manual has been carefully checked and is believed to be accurate; however, no responsibility is assumed for clerical, typographical, or proofreading errors, or omissions.

## Safety Precautions

### ■ Definition of Precautionary Information

The following notation is used in this manual to provide precautions required to ensure safe usage of the product.

The safety precautions that are provided are extremely important to safety. Always read and heed the information provided in all safety precautions.

The following notation is used.







**CAUTION**

Indicates a potentially hazardous situation which, if not avoided, is likely to result in minor or moderate injury or in property damage.

### ■ Symbols

Symbol		Meaning
Caution		<b>General Caution</b> Indicates non-specific general cautions, warnings, and dangers.
		<b>Electrical Shock Caution</b> Indicates possibility of electric shock under specific conditions.
Prohibition		<b>General Prohibition</b> Indicates non-specific general prohibitions.
Mandatory Caution		<b>General Caution</b> Indicates non-specific general cautions, warnings, and dangers.

## ■ Safety Precautions

 <b>CAUTION</b>	
Do not touch the terminals while power is being supplied. Doing so may occasionally result in minor injury due to electric shock.	
Do not allow pieces of metal, wire clippings, or fine metallic shavings or filings from installation to enter the product. Doing so may occasionally result in electric shock, fire, or malfunction.	
Do not use the product where subject to flammable or explosive gas. Otherwise, minor injury from explosion may occasionally occur.	
Never disassemble, modify, or repair the product or touch any of the internal parts. Minor electric shock, fire, or malfunction may occasionally occur.	
<p><b>CAUTION - Risk of Fire and Electric Shock</b></p> <p>a) This product is UL listed as Open Type Process Control Equipment. It must be mounted in an enclosure that does not allow fire to escape externally.</p> <p>b) When using more than one shutoff switch, always turn OFF all the shutoff switches to ensure that no power is being supplied before servicing the product.</p> <p>c) Signal inputs are SELV, limited energy. (See note 1.)</p> <p>d) Caution: To reduce the risk of fire or electric shock, do not interconnect the outputs of different Class 2 circuits. (See note 2.)</p>	
If the output relays are used past their life expectancy, contact fusing or burning may occasionally occur. Always consider the application conditions and use the output relays within their rated load and electrical life expectancy. The life expectancy of output relays varies considerably with the output load and switching conditions.	

Note 1: An SELV circuit is one separated from the power supply with double insulation or reinforced insulation, that does not exceed 30 V r.m.s. and 42.4 V peak or 60 VDC.

Note 2: A class 2 power supply is one tested and certified by UL as having the current and voltage of the secondary output restricted to specific levels.

 **CAUTION**

Tighten the terminal screws to between 0.74 and 0.90 N·m. Loose screws may occasionally result in fire. (See note 3.)

Set the parameters of the product so that they are suitable for the system being controlled. If they are not suitable, unexpected operation may occasionally result in property damage or accidents.

A malfunction in the Temperature Controller may occasionally make control operations impossible or prevent alarm outputs, resulting in property damage. To maintain safety in the event of malfunction of the Temperature Controller, take appropriate safety measures, such as installing a monitoring device on a separate line.

A semiconductor is used in the output section of long-life relays. If excessive noise or surge is impressed on the output terminals, a short-circuit failure is likely to occur. If the output remains shorted, fire will occur due to overheating of the heater or other cause. Take measures in the overall system to prevent excessive temperature increase and to prevent fire from spreading.

When inserting the body of the Temperature Controller into the case, confirm that the hooks on the top and bottom are securely engaged with the case. If the body of the Temperature Controller is not inserted properly, faulty contact in the terminal section or reduced water resistance may occasionally result in fire or malfunction.



Note 3: The tightening torque is 0.5 N·m for the E5CN-U and 0.43 to 0.58 N·m for the E5GN. The terminal torque is 0.5 to 0.6 N·m for auxiliary output 2 on the E5GN.



## Precautions for Safe Use

Be sure to observe the following precautions to prevent operation failure, malfunction, or adverse affects on the performance and functions of the product. Not doing so may occasionally result in unexpected events. Use the product within specifications.

- 1) The product is designed for indoor use only. Do not use or store the product in any of the following locations.
  - Places directly subject to heat radiated from heating equipment.
  - Places subject to splashing liquid or oil atmosphere.
  - Places subject to direct sunlight.
  - Places subject to dust or corrosive gas (in particular, sulfide gas and ammonia gas).
  - Places subject to intense temperature change.
  - Places subject to icing and condensation.
  - Places subject to vibration and large shocks.

- 2) Use and store the Digital Temperature Controller within the rated ambient temperature and humidity. Gang-mounting two or more temperature controllers, or mounting temperature controllers above each other may cause heat to build up inside the temperature controllers, which will shorten their service life. In such a case, use forced cooling by fans or other means of air ventilation to cool down the Digital Temperature Controllers.

- 3) To allow heat to escape, do not block the area around the product. Do not block the ventilation holes on the product.

- 4) Be sure to wire properly with correct polarity of terminals.

- 5) Use the specified size of crimp terminals for the E5CN, E5AN, or E5EN (M3.5, width of 7.2 mm or less). For open-wired connections to the E5CN, E5AN, or E5EN, use stranded or solid copper wires with a gauge of AWG24 to AWG14 (equal to a cross-sectional area of 0.205 to 2.081 mm<sup>2</sup>). (The stripping length is 5 to 6 mm.) Up to two wires of the same size and type or two crimp terminals can be connected to one terminal. Do not connect more than two wires or more than two crimp terminals to the same terminal.

Use the specified size of crimp terminals for the E5GN (M3.0, width of 5.8 mm or less). For open-wired connections to the E5GN, use stranded or solid copper wires with a gauge of AWG24 to AWG18 (equal to a cross-sectional area of 0.205 to 0.8231 mm<sup>2</sup>). (The stripping length for screw terminals is 6 to 8 mm. The stripping length for screwless clamp terminals is 10 mm. The stripping length for auxiliary output 2 is 6 mm.) Up to two wires of the same size and type or two crimp terminals can be connected to one terminal. Do not connect more than two wires or more than two crimp terminals to the same terminal.

Ferrules for screwless clamp terminals must be 0.8 to 1.4 mm in diameter and the exposed conductor must be 8 to 12 mm in length. Ferrules for auxiliary output 2 must be 0.8 to 1.4 mm in diameter and the exposed conductor must be 6 mm in length.

- 6) Do not wire the terminals which are not used.

- 7) To avoid inductive noise, keep the wiring for the Digital Temperature Controller's terminal block away from power cables carry high voltages or large currents. Also, do not wire power lines together with or parallel to Digital Temperature Controller wiring. Using shielded cables and using separate conduits or ducts is recommended.

Attach a surge suppressor or noise filter to peripheral devices that generate noise (in particular, motors, transformers, solenoids, magnetic coils or other equipment that have an inductance component).

When a noise filter is used at the power supply, first check the voltage or current, and attach the noise filter as close as possible to the temperature controller.

Allow as much space as possible between the Digital Temperature Controller and devices that generate powerful high frequencies (high-frequency welders, high-frequency sewing machines, etc.) or surge.

- 8) Use this product within the rated load and power supply.
- 9) Make sure that the rated voltage is attained within two seconds of turning ON the power using a switch or relay contact. If the voltage is applied gradually, the power may not be reset or output malfunctions may occur.
- 10) Make sure that the Temperature Controller has 30 minutes or more to warm up after turning ON the power before starting actual control operations to ensure the correct temperature display.
- 11) When using self-tuning, turn ON power for the load (e.g., heater) at the same time as or before supplying power to the Digital Temperature Controller. If power is turned ON for the Digital Temperature Controller before turning ON power for the load, self-tuning will not be performed properly and optimum control will not be achieved.
- 12) A switch or circuit breaker should be provided close to this unit. The switch or circuit breaker should be within easy reach of the operator, and must be marked as a disconnecting means for this unit.
- 13) Always turn OFF the power supply before pulling out the interior of the E5CN, E5AN, or E5EN, and never touch nor apply shock to the terminals or electronic components. When inserting the interior of the product, do not allow the electronic components to touch the case.  
Always turn OFF the power supply before removing the terminal block from the E5GN, and never touch nor apply shock to the terminals or electronic components.
- 14) Do not use paint thinner or similar chemical to clean with. Use standard grade alcohol.
- 15) Design system (control panel, etc) considering the 2 second of delay that the controller's output to be set after power ON.
- 16) The outputs may turn OFF when shifting to certain levels, such as the initial setting level. Take this into consideration when performing control.
- 17) The number of EEPROM write operations is limited. Therefore, use RAM write mode when frequently overwriting data during communications or others operations.
- 18) Always touch a grounded piece of metal before touching the Digital Temperature Controller to discharge static electricity from your body.
- 19) Do not remove the terminal block from the E5CN, E5AN, or E5EN. Doing so may result in failure or malfunction.
- 20) Control outputs that are voltage outputs are not isolated from the internal circuits. When using a grounded thermocouple, do not connect any of the control output terminals to ground. (Doing so may result in an unwanted circuit path, causing error in the measured temperature.)
- 21) When replacing the body of the E5CN, E5AN, or E5EN, check the condition of the terminals. If corroded terminals are used, contact failure in the terminals may cause the temperature inside the Digital Temperature Controller to increase, possibly resulting in fire. If the terminals are corroded, replace the case as well.  
When pulling out the terminal block of the E5GN to replace the Digital Temperature Controller, check the condition of the terminals. If corroded terminals are used, contact failure in the terminals may cause the temperature inside the Digital Temperature Controller to increase, possibly resulting in fire. If the terminals are corroded, replace the terminal block as well.
- 22) Use suitable tools when taking the Digital Temperature Controller apart for disposal. Sharp parts inside the Digital Temperature Controller may cause injury.
- 23) When applying Lloyd's standards, install the Digital Temperature Controller according to the requirements given in Shipping Standards in the E5CN, E5AN, E5EN, E5GN User's Manual (Cat. No. H156).
- 24) Do not use the Temperature Controller if the front sheet is peeling or torn.

# Conventions Used in This Manual

## ■ How This Manual is Organized

Descriptions in this manual are separated by the communications method.

Read the sections that are application to the system being used.

Overview

CompoWay/F

Communications Data  
for CompoWay/F•SYSWAY

SYSWAY

Modbus

Communications Data  
for Modbus

Appendix

## ■ Related Manuals

This manual describes the communications functions of the E5CN/AN/EN/GN.

For details on the functions of the E5CN/AN/EN/GN, refer to the User's Manual (H156).

Overview

CompoWay/F

Com Data for  
CompoWay/F

SYSWAY

Modbus

Com Data  
for Modbus

Appendix



# Table of Contents

---

	Preface .....	-I
	Conventions Used in This Manual .....	-IX
<b>SECTION 1</b>		
<b>Communications Methods</b>		
1.1	Overview of Communications Methods .....	1-2
	Introduction .....	1-2
	Communications Specifications .....	1-3
	Transmission Procedure .....	1-3
	Interface .....	1-4
	Wiring .....	1-4
	Communications Parameters .....	1-7
<b>SECTION 2</b>		
<b>CompoWay/F Communications Procedures</b>		
2.1	Data Format .....	2-2
	Command Frame .....	2-2
	Response Frame .....	2-3
	Communications Data .....	2-4
	End Code Example .....	2-4
2.2	Structure of Command Text .....	2-6
	PDU Structure .....	2-6
	Area Definitions .....	2-6
	Type Code (Variable Type) .....	2-6
	Addresses .....	2-7
	Number of Elements .....	2-7
	List of Services (Main Request Codes and Sub-Request Codes) .....	2-7
2.3	Detailed Description of the Services .....	2-9
	Read Variable Area .....	2-9
	Write Variable Area .....	2-10
	Composite Read from Variable Area .....	2-12
	Composite Write to Variable Area .....	2-13
	Read Controller Attributes .....	2-16
	Read Controller Status .....	2-17
	Echoback Test .....	2-18
	Operation Command .....	2-19
2.4	Response Code List .....	2-26
<b>SECTION 3</b>		
<b>Communications Data for CompoWay/F and SYSWAY</b>		
3.1	Variable Area (Setting Range) List .....	3-2
3.2	Status and Status 2 .....	3-15
	Status Structure .....	3-15
	Status 2 Structure .....	3-17
	Status Details .....	3-18
	Status 2 Details .....	3-19

## SECTION 4

### SYSWAY (E5□J and E5□X Format) Communications Procedures

4.1	Data Format .....	4-2
	Command Frame Format .....	4-2
	Response Frame .....	4-3
	Communications Data .....	4-3
	SYSWAY Command Lists .....	4-4
4.2	Command Descriptions .....	4-5
	Read Process Value .....	4-5
	Write Set Values .....	4-6
	Read Set Values and MV Monitor .....	4-7
	Select Communications Writing .....	4-9

## SECTION 5

### Modbus Communications Procedure

5.1	Data Format .....	5-2
	Command Frame .....	5-2
	Response Frame .....	5-4
	Error Codes .....	5-5
5.2	Function List .....	5-6
5.3	Variable Area .....	5-7
5.4	Detailed Description of the Services .....	5-9
	Variable Read, Multiple .....	5-9
	Variable Write, Multiple .....	5-11
	Variable Write, Single/Operation Command .....	5-14
	Echoback Test .....	5-20

## SECTION 6

### Communications Data for Modbus

6.1	Variable Area (Setting Range) List .....	6-2
6.2	Status and status 2 .....	6-17
	Status Structure .....	6-17
	Status 2 Structure .....	6-19
	Status Details .....	6-20
	Status 2 Details .....	6-21

## Appendix

ASCII List .....	A-2
Troubleshooting .....	A-3

Index .....	I-1
Revision History .....	R-1

# SECTION 1

## Communications Methods

This section briefly describes the supported communications methods and how to wire equipment. Refer to this section when setting up equipment.

1.1	Overview of Communications Methods .....	1-2
	Introduction.....	1-2
	Communications Specifications.....	1-3
	Transmission Procedure.....	1-3
	Interface.....	1-4
	Wiring .....	1-4
	RS-485 .....	1-4
	RS-232C (E5AN, E5EN, and E5GN Only).....	1-6
	Communications Parameters .....	1-7
	Communications Parameter Setup .....	1-7
	Communications Parameters .....	1-8
	Setting Communications Writing .....	1-9

# 1.1 Overview of Communications Methods

## ■ Introduction

The program for the communications functions are created on the host (personal computer, PLC, or other type of communications master), and the E5CN/AN/EN/GN's parameters are monitored or set from the host. Therefore, the description provided here is from the viewpoint of the host.

CompoWay/F is OMRON's standard communications format for general serial communications. This format uses a standard frame format as well as the well-established FINS\* commands used for OMRON's PLCs. Therefore, it can simplify communications between components and the host.

\*FINS (Factory Interface Network service)

The FINS protocol provides message communications between controllers in OMRON FA networks.

Modbus is a standard communications control method that conforms to the Modicon Company's RTU-mode Modbus Protocol (PI-MBUS-300 Revision J).

Modbus is a registered trademark of Schneider Electric.

It supports functions equivalent to the CompoWay/F Read Variable Area, Write Variable Area, Operation Command, and Echoback Test functions.

The E5CN/AN/EN/GN supports the following communications functions.

- Reading/writing of parameters
- Operation instructions
- Selection of setup levels

Communications are subject to the following condition:

- Parameters can be written only when the Communications Writing parameter is set to ON (enabled).



## ■ Communications Specifications

Transmission line connection	RS-485: Multidrop RS-232C: Point-to-point
Communications method (See note 1.)	RS-485 (2-wire, half-duplex)/RS-232C
Synchronization method	Start-stop synchronization
Communications baud rate (See note 2.)	1,200, 2,400, 4,800, <b>9,600</b> , 19,200, 38,400 or 57,600 bps
Communications code	ASCII
Communications data length (See notes 2 and 3.)	<b>7</b> or 8 bits
Communications stop bits (See note 2.)	1 or <b>2</b> bits
Error detection	Vertical parity (none, <b>even</b> , or odd) (See note 2.) FCS (Frame Check Sequence) with SYSWAY communications BCC (Block Check Character) with CompoWay/F communications CRC-16 (Cyclic Redundancy Check 16) with Modbus communications
Flow control	None
Interface	RS-485/RS-232C
Retry function	None
Communications buffer	217 bytes
Send data wait time	0 to 99 ms, default time: 20 ms

Note 1: RS-232C is supported by E5AN, E5EN, and E5GN only.

Note 2: Communications baud rate, data length, stop bits and vertical parity can each be set independently in the communications setting level. Highlighted values indicate default settings.

Note 3: The communications data length for Modbus must be 8 bits.

## ■ Transmission Procedure

When the host transmits a command frame, the E5CN/AN/EN/GN transmits a response frame that corresponds to the command frame. A single response frame is returned for each command frame. The following diagram shows the operation of the command and response frames.

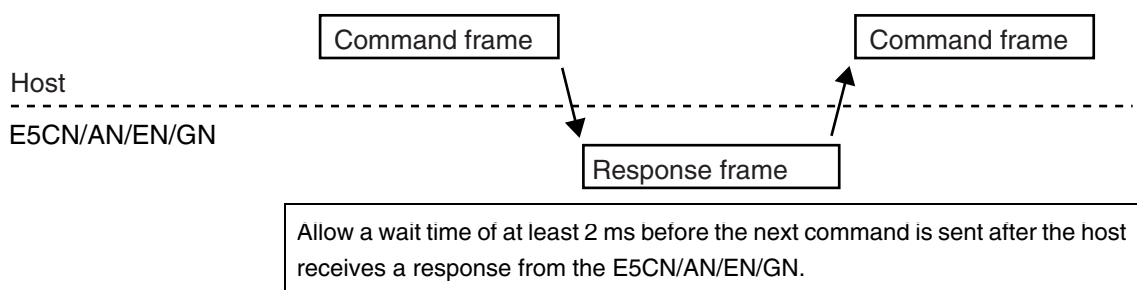

## Interface

Communications with the host are carried out through a standard RS-485 interface or RS-232C interface (E5AN, E5EN, and E5GN only). Use a K3SC Interface Converter for RS-485 and RS-232C interface conversion.

## Wiring

### RS-485

- The RS-485 connection can be either one-to-one or one-to-N. Up to 32 units including the host can be connected in a one-to-N system.
- The total cable length is 500 m max.
- Use a shielded, AWG24 to AWG14 (cross-sectional area of 0.205 to 2.081 mm<sup>2</sup>) twisted-pair cable for the E5CN, E5EN, or E5AN. Use a shielded, AWG24 to AWG18 (cross-sectional area of 0.205 to 0.823 mm<sup>2</sup>) twisted-pair cable for the E5GN. The stripping length is 5 to 6 mm for the E5CN, E5AN, or E5EN, and 6 to 8 mm for the E5GN.

### E5CN

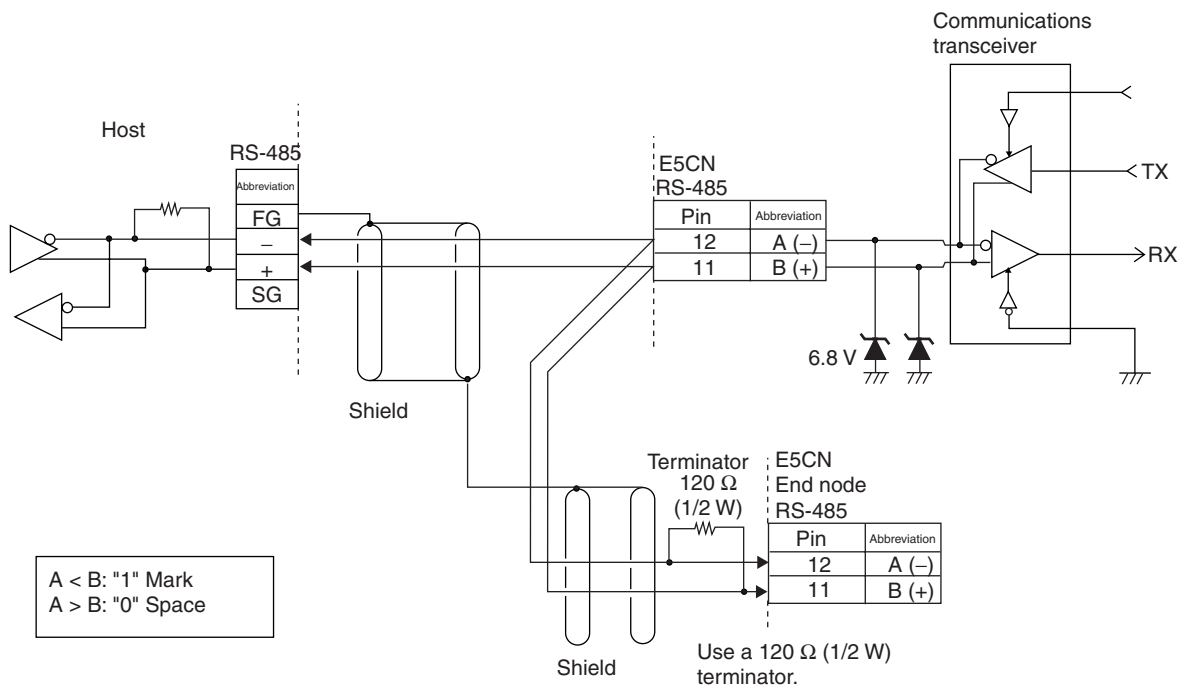

Specify both ends of the transmission path including the host as the end node (that is, connect terminators to both ends). Use a terminating resistance of at least 54 Ω.

● E5AN/EN

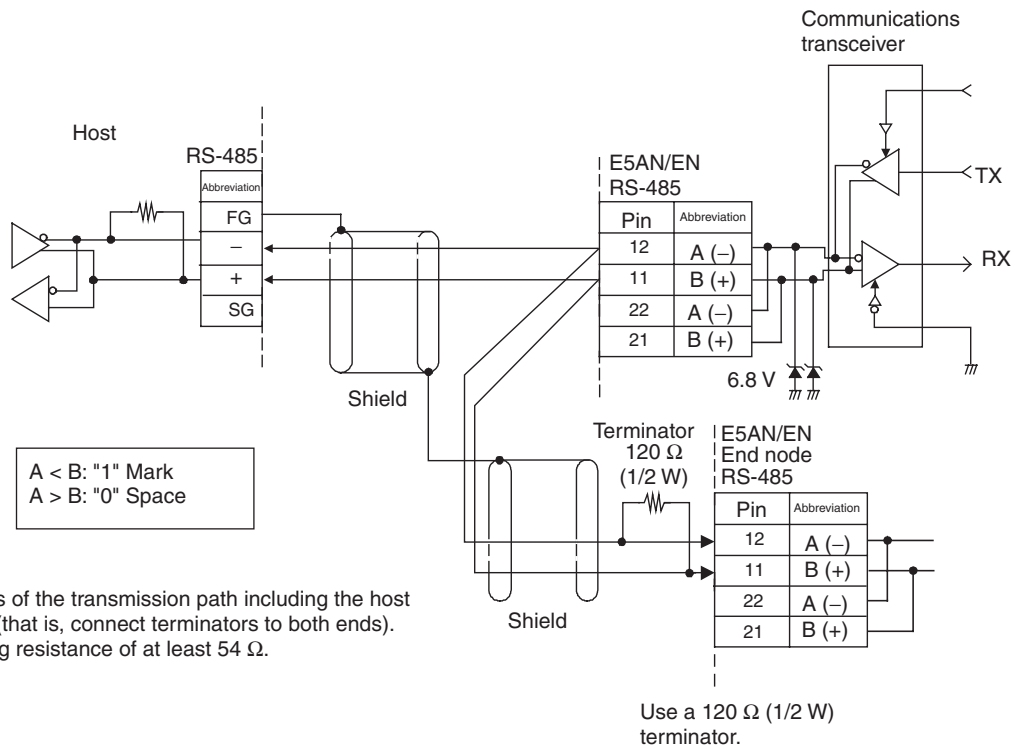

Specify both ends of the transmission path including the host as the end node (that is, connect terminators to both ends). Use a terminating resistance of at least 54 Ω.

● E5GN

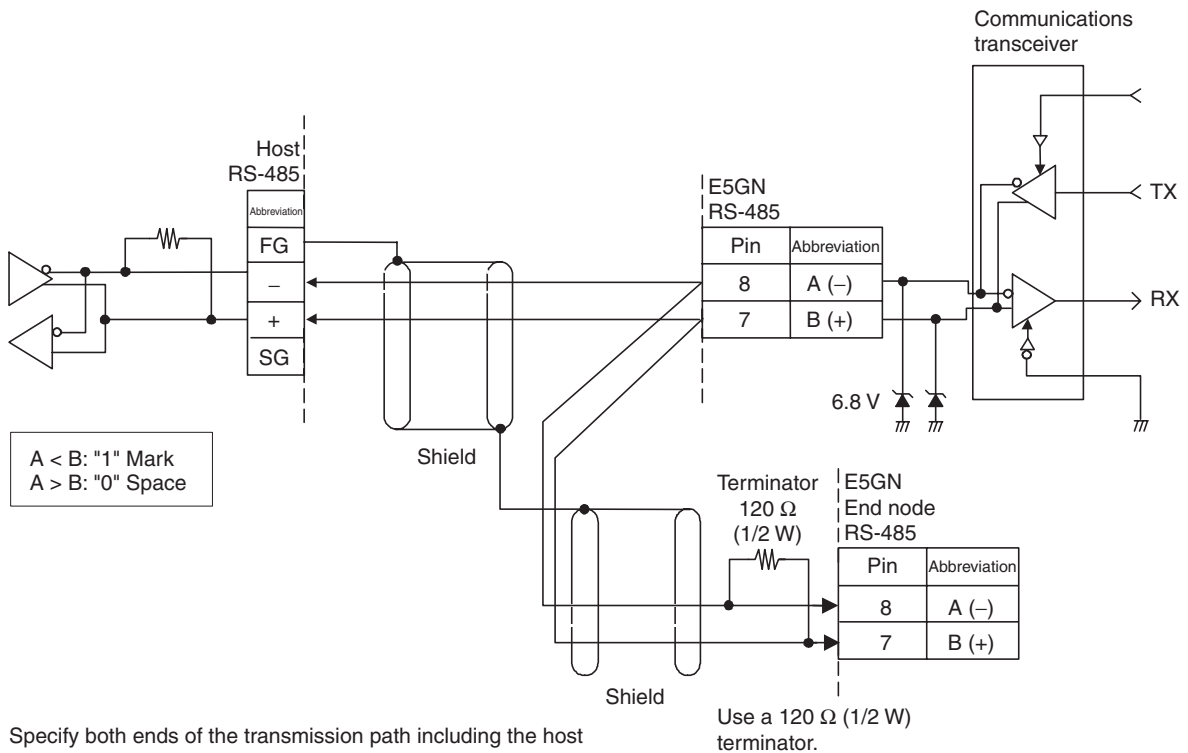

Specify both ends of the transmission path including the host as the end node (that is, connect terminators to both ends). Use a terminating resistance of at least 54 Ω.

Match the communications specifications of the E5CN/AN/EN/GN and the host. When using a 1: N connection, set the same communications specifications in all of the Units. (Of course, each Unit must have a unique unit number.)

This section explains how to set the E5CN/AN/EN/GN's communications specifications. For details on the host, refer to the User's Manual provided with the host.

### ● RS-232C (E5AN, E5EN, and E5GN Only)

- A 1:1 connection is used.
- The maximum cable length is 15 m. To extend the transmission path, use the OMRON Z3R RS-232C Optical Interface.
- Use a shielded, AWG24 to AWG14 (cross-sectional area of 0.205 to 2.081 mm<sup>2</sup>) twisted-pair cable for the E5CN, E5EN, or E5AN. Use a shielded, AWG24 to AWG18 (cross-sectional area of 0.205 to 0.823 mm<sup>2</sup>) twisted-pair cable for the E5GN. The stripping length is 5 to 6 mm for the E5CN, E5AN, or E5EN, and 6 to 8 mm for the E5GN.

### ● E5AN/EN

Host

RS-232C: 25-pin

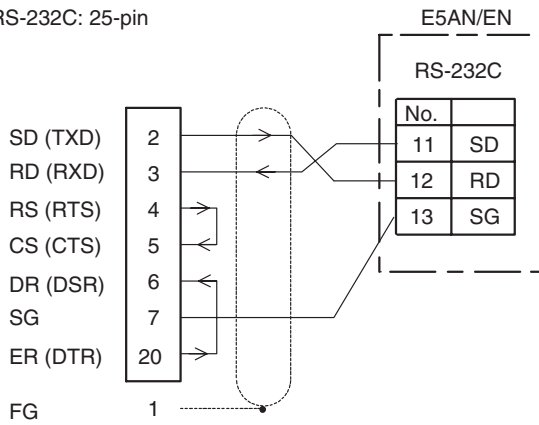

Host (IBM PC/AT or compatible)

RS-232C: 9-pin

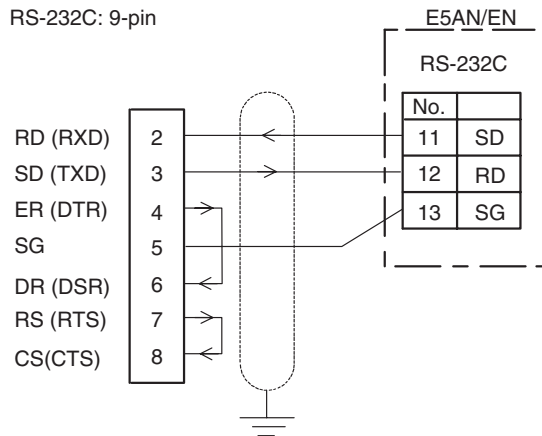

### ● E5GN

Host

RS-232C: 25-pin

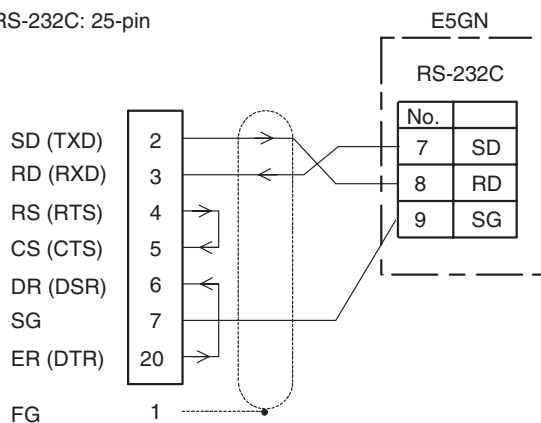

Host (IBM PC/AT or compatible)

RS-232C: 9-pin

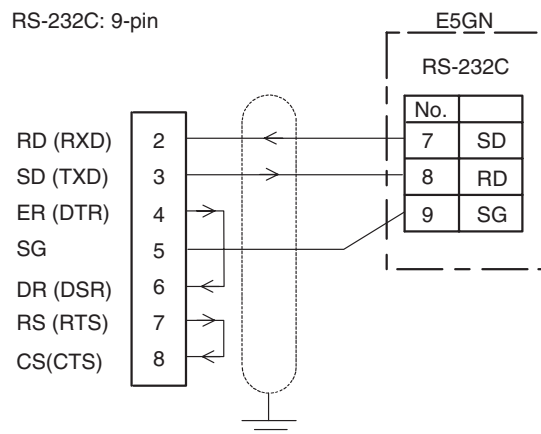

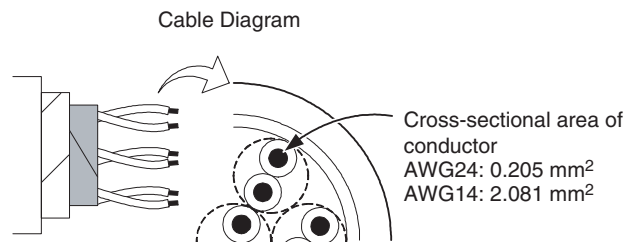

## ■ Communications Parameters

The E5CN/AN/EN/GN's communications specifications are set in the communications setting level. These parameters are set on the E5CN/AN/EN/GN's front panel. The following table shows the communications parameters and their setting ranges.

Item	Code	Settings	Set Values
Communications protocol	<i>PSEL</i>	CompoWay/F (SYSWAY)/Modbus	<b>FWF</b> /Mod
Communications unit number	<i>U-Nō</i>	0 to 99	0, <b>1</b> to 99
Communications baud rate	<i>bPS</i>	1.2/2.4/4.8/9.6/19.2/38.4/57.6 (kbit/s)	1.2/2.4/4.8/ <b>9.6</b> /19.2/38.4/57.6 (kbit/s)
Communications data length (See note.)	<i>LEN</i>	7/8 (bit)	<b>7</b> /8 (bit)
Communications stop bits	<i>Sbct</i>	1/2	1/ <b>2</b>
Communications parity	<i>PRTY</i>	None, Even, Odd	NONE/ <b>EVEN</b> /odd
Send data wait time	<i>SDWT</i>	0 to 99	0 to 99 ms, default time: <b>20</b> ms



Highlighted values indicate default settings.

Note: The communications data length for Modbus must be 8 bits.

## ● Communications Parameter Setup

Before you carry out communications with the E5CN/AN/EN/GN, set up the communications unit number, baud rate, and other parameters by carrying out the following procedure. For details on operations other than communications parameter setup, refer to the *E5CN/E5AN/E5EN/E5GN Digital Temperature Controllers User's Manual Basic Type* (Cat. No. H156) for the devices being used.

1. Press the Key for at least three seconds to move from the "operation level" to the "initial setting level."
2. Press the Key for less than one second to move from the "initial setting level" to the "communications setting level."
3. Select the parameters as shown below by pressing the Key.

4. Use the  or  Keys to change the parameter set values.

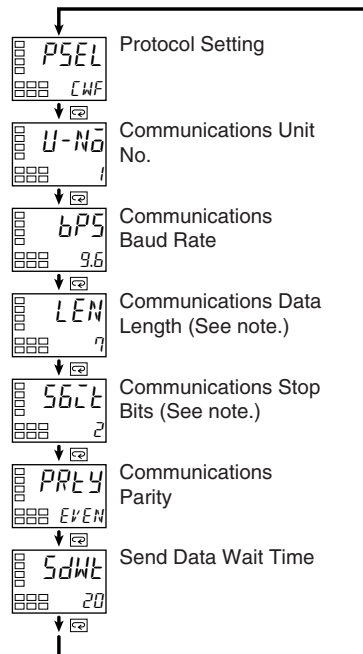

Note: Displayed only when the Protocol Setting parameter is set to CompoWay/F.

### ● Communications Parameters

When communications parameter settings have been changed, the new settings must be enabled by resetting the Controller.





- Protocol Setting (*PSEL*)  
The communications protocol can be selected. Set CompoWay/F (SYSWAY) or Modbus.
- Communications Unit No. (*U-Nb*)  
This parameter is for setting a unique unit number for each of the Temperature Controllers. This unit number is set so that the host can identify the Temperature Controller when communications are carried out with the host. The unit number can be set to an integer value between 0 and 99. The default is "1." When two or more Temperature Controllers are used, do not set the same unit number. Doing so will prevent normal operation.
- Communications Baud Rate (*bPS*)  
This parameter is for setting the baud rate for communications with the host. The communications baud rate settings are as follows: 1.2 (1200 bps), 2.4 (2400 bps), 4.8 (4800 bps), 9.6 (9600 bps), 19.2 (19200 bps), 38.4 (38400 bps) or 57.6 (57600 bps)
- Communications Data Length (*LEN*)  
This parameter is for setting the number of communications data bits. Set either "7 bits" or "8 bits."

- **Communications Stop Bits (*Sb̄t*)**  
This parameter is for setting the number of communications stop bits. Set either “1” or “2.”
- **Communications Parity (*PR̄t*)**  
The communications parity can be set. Set the parity to “none,” “even,” or “odd.”
- **Send Data Wait Time (*Sd̄t*)**  
The send data wait time is the delay from when the Controller receives a command from the host computer until it returns a response. If the response is returned too quickly, the host computer may not be able to receive the response. Change the send data wait time as required. To increase the response speed for communications, reduce the send data wait time. The send data wait time can be set in 1-ms increments between 0 and 99 ms. The default is 20 ms.

### ● Setting Communications Writing

Set the communications writing parameter to ON to allow the host to write to the E5CN/AN/EN/GN via communications.

#### Parameter Setting

1. Press the  Key for less than one second to move from the operation level to the adjustment level.
2. Select the parameter as shown below by pressing the  Key.
3. Press the  or  Key to set the communications writing parameter to ON.

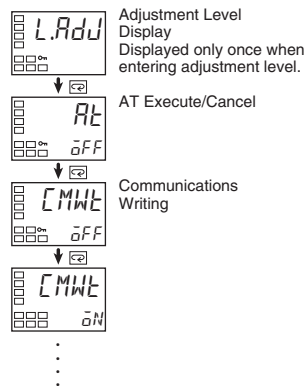





# SECTION 2

## CompoWay/F Communications Procedures

Read this section if you are to communicate using the CompoWay/F format.

2.1	Data Format.....	2-2
	Command Frame.....	2-2
	BCC Calculation Example .....	2-3
	Response Frame .....	2-3
	Communications Data .....	2-4
	End Code Example.....	2-4
2.2	Structure of Command Text .....	2-6
	PDU Structure .....	2-6
	Area Definitions .....	2-6
	Type Code (Variable Type) .....	2-6
	Addresses.....	2-7
	Number of Elements.....	2-7
	List of Services (Main Request Codes and Sub-Request Codes).....	2-7
2.3	Detailed Description of the Services.....	2-9
	Read Variable Area .....	2-9
	Write Variable Area .....	2-10
	Composite Read from Variable Area.....	2-12
	Composite Write to Variable Area .....	2-13
	Read Controller Attributes .....	2-16
	Read Controller Status .....	2-17
	Echoback Test.....	2-18
	Operation Command .....	2-19
2.4	Response Code List .....	2-26

## 2.1 Data Format

Hexadecimal values are expressed by adding the prefix H' before the number, e.g., H'02. Numbers shown without the H' prefix are ASCII characters.

The number underneath each item in a frame indicates the number of bytes.

### ■ Command Frame

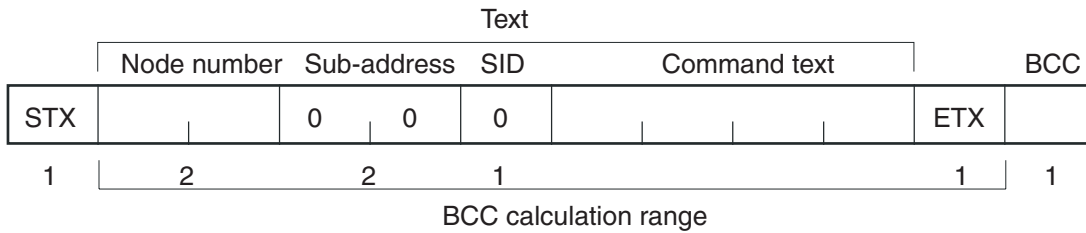

STX	This code (H'02) indicates the beginning of the communications frame (text). Always set this character in the first byte. When STX is received again during reception, reception is carried out again from the point where STX was received.
Node number	<ul style="list-style-type: none"> <li>This number specifies the transmission's destination.</li> <li>Specify the E5CN/AN/EN/GN's communications unit number.</li> <li>A BCD value between 00 and 99 or an ASCII value of XX can be set.</li> <li>Specify "XX" for a broadcast transmission. No responses will be returned for broadcast transmissions.</li> <li>No responses will be returned from node numbers other than the ones in the above range.</li> </ul>
Sub-address	The sub-address is not used in the E5CN/AN/EN/GN. Be sure to set the sub-address to "00."
SID (Service ID)	The service ID is not used in the E5CN/AN/EN/GN. Be sure to set the service ID to "00."
Command text	This is the command text area. For details, see <i>2.2 Structure of Command Text</i> .
ETX	This code (H'03) indicates the end of the text.
BCC	This is the Block Check Character. The BCC result is found by calculating the exclusive OR of the bytes from the node number up to ETX.

## ● BCC Calculation Example

The BCC (Block Check Character) is determined by calculating the exclusive OR of the bytes from the node number up to ETX. The 8-bit result is written to the BCC byte at the end of the frame.

STX	Node number	Sub-address	SID	Command text	ETX	BCC
02H	0 (30H)0 (30H)0 (30H)0 (30H)0 (30H)0 (30H)5 (35H)0 (30H)3 (33H)				03H	35H

$BCC = 30H \oplus 30H \oplus 30H \oplus 30H \oplus 30H \oplus 30H \oplus 30H \oplus 35H \oplus 30H \oplus 33H \oplus 03H = 35H$   
 The result of the calculation (35 hex) is written to the BCC byte.

The ⊕ symbols indicate XOR (exclusive OR) operations.

## ■ Response Frame

STX	Node number	Sub-address	End code	Command text	ETX	BCC
	0	0				
1	2	2	2		1	1

End code	Name	Description	Error detection priority
00	Normal completion	The command ended normally without error.	None
0F	FINS command error	The specified FINS command could not be executed. The FINS response code should indicate why the command could not be executed.	8
10	Parity error	The sum total of bits whose received data is "1" does not match the set value of the "communications parity" bit.	2
11	Framing error	Stop bit is "0."	1
12	Overrun error	An attempt was made to transfer new data when the reception data buffer was already full.	3
13	BCC error	The calculated BCC value is different from the received BCC value.	5
14	Format error	<ul style="list-style-type: none"> <li>The command text contains characters other than 0 to 9, and A to F. This error does not apply to Echoback Tests. (Refer to the Echoback Test for details.)</li> <li>There was no SID and command text. There was no command text.</li> <li>"MRC/SRC" not included in command text.</li> </ul>	7
16	Sub-address error	<ul style="list-style-type: none"> <li>Illegal (unsupported) sub-address</li> <li>There was no sub-address, SID, and command text.</li> <li>Sub-address was less than two characters, and there was no SID and command text</li> </ul>	6
18	Frame length error	The received frame exceeds the specified (supported) number of bytes.	4

- An end code is returned for each command frame received that was addressed to the local node.
- No response will be returned unless the frame contained all elements up to the ETX and BCC.
- "Error Detection Priority" indicates the priority when two or more errors occur simultaneously.

## ■ Communications Data

Communications format	Set (monitor) values	Negative values	Decimal point
CompoWay/F	8-digit hexa-decimal	2's complement	Decimal point is removed and the result is converted to hexadecimal. Example conversion: 105.0 → 1050 → H'0000041A

## ■ End Code Example

The following examples show the end code when a command did not end normally.

Example 1) Illegal Sub-address, No SID, and No Command Text  
Command

	Node number	Sub-address	BCC
STX		0   A	EXT

Response

	Node number	Sub-address	End code	BCC
STX		0   A	1   6	EXT

End code is "16" (sub-address error).

The sub-address error code is used because the sub-address error has a higher error detection priority than the format error.

Example 2) No Command Text  
Command

	Node number	Sub-address	SID	BCC
STX		0   0	0	EXT

Response

	Node number	Sub-address	End code	BCC
STX		0   0	1   4	EXT

The end code is "14" (format error).

Example 3) No Node Number Provided  
Command

	BCC
STX	EXT

The node number is lacking one character.

Response

There is no response.

## Example 4) No Sub-address and Illegal BCC

Command

Node number		BCC	
STX		EXT	Err

Response

Node number		Sub-address		End code		BCC	
STX		0	0	1	3	EXT	

The sub-address is "00" and the end code is "13" (BCC error).

## 2.2 Structure of Command Text

### ■ PDU Structure

An MRC (Main Request Code) and SRC (Sub-Request Code) followed by the various required data is transferred to the command text.

Service Request PDU



The MRES (Main Response Code) and SRES (Sub-Response Code) are transferred to the response frame following the above MRC/SRC. Data is then transferred following the MRES and SRES.

Service Response PDU (Normal Response)



If the specified command text could not be executed, the service response PDU will contain only the MRC/SRC and MRES/SRES.

Service Response PDU (Command Text Not Executed)



MRES/SRES provides the response code. MRES/SRES are not output when processing ends in a normal completion.

### ■ Area Definitions

Areas comprise only the variable area.

### ■ Type Code (Variable Type)

The following tables show the variable area type codes.

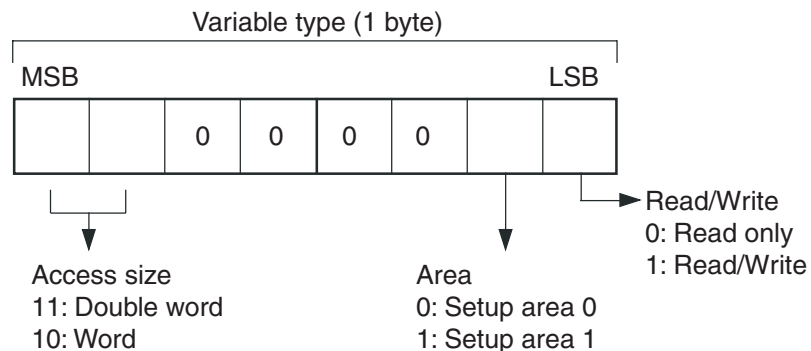

The following table summarizes setup areas 0 and 1.

Area	Description
Setup area 0	This area groups together the protect, manual control, operation, and adjustment levels.
Setup area 1	This area groups together the initial setting, communications setting, advanced function setting, and calibration levels.

The type code depends on the parameter. Refer to *3.1 Variable Area (Setting Range) List* for details.

The variable type is converted to 2-byte ASCII and loaded to the frame. The following table shows the available variable types.

Variable type	Description
C0/80	R/O (read only) parameter for setup area 0.
C1/81	R/W parameter for setup area 0.
C3/83	R/W parameter for setup area 1.

Note: Setup area 1 has no read-only parameters, so there is no variable type "C2."

## ■ Addresses

An address is appended to each of the variable types. Express addresses in 2-byte hexadecimal and append them for the specified access size. The address depends on the parameter. Refer to *3.1 Variable Area (Setting Range) List* for details.

## ■ Number of Elements

The number of elements is expressed in 2-byte hexadecimal. The range that can be specified for the number of elements depends on the command. Refer to *2.3 Detailed Description of the Services* for details.

## ■ List of Services (Main Request Codes and Sub-Request Codes)

MRC	SRC	Name of service	Processing
01	01	Read Variable Area	This service reads from the variable area.
01	02	Write Variable Area	This service writes to the variable area.
01	04	Composite Read from Variable Area	This service reads from the variable area in the order specified by the parameters.
01	13	Composite Write to Variable Area	This service writes to the variable area in the order specified by the parameters.
05	03	Read Controller Attributes	This service reads the model number and communications buffer size.

MRC	SRC	Name of service	Processing
06	01	Read Controller Status	This service reads the operating status.
08	01	Echoback Test	This service performs an echoback test.
30	05	Operation Command	This service performs operations such as RUN/STOP, executing/stopping AT (auto-tuning), and moving to Setup Area 1.

Note: No commands will be accepted and no responses will be returned when a memory error (RAM error) has occurred or the Controller is initializing (until the Controller recognizes the process value after the power is turned ON).



## 2.3 Detailed Description of the Services

### ■ Read Variable Area

This service reads data from the variable area.

Service Request PDU

MRC	SRC	Variable type	Read start address	Bit position	Number of elements
0   1	0   1			0   0	
2	2	2	4	2	4

Service Response PDU

MRC	SRC	Response code	Read data (for number of elements)
0   1	0   1		
2	2	4	Number of elements × 8 or 4

(1) Variable Type and Read Start Address

For details on variable types and read start addresses, see *SECTION 3 Communications Data for CompoWay/F and SYSWAY*.

(2) Bit Position

The E5CN/AN/EN/GN does not support bit access. Fixed to “00.”

(3) Number of Elements

Number of elements	Processing
0000	The read operation is not performed (read data is not appended to the service response PDU), and processing ends in “normal completion.”
Double word (variable type C0, C1, or C3)	The read operation is performed and processing ends in a normal completion.
Word (variable type 80, 81, or 83)	

(4) Response Code

Normal Completion

Response code	Name	Description
0000	Normal completion	No errors were found.

Error Occurred

Response code	Error name	Cause
1001	Command too long	The command is too long.
1002	Command too short	The command is too short.

Response code	Error name	Cause
1101	Area type error	The variable type is wrong.
1103	Start address out-of-range error	The read start address is out of range.
110B	Response too long	The number of elements exceeds the maximum.
1100	Parameter error	Bit position is not "00."
2203	Operation error	EEPROM error

## (5) Precautions

## ● Alarm Function

Even though alarms are not displayed on the Controller's display, they function normally in communications.

## ■ Write Variable Area

This service writes data to the variable area.

## Service Request PDU

MRC	SRC	Variable type	Start write address	Bit position	Number of elements	Write Data (for number of elements)
0   1	0   2			0   0		
2	2	2	4	2	4	Number of elements × 8 or 4

## Service Response PDU

MRC	SRC	Response code
0   1	0   2	
2	2	4

## (1) Variable Type and Write Start Address

For details on variable types and write start addresses, see *SECTION 3 Communications Data for CompoWay/F and SYSWAY*.

## (2) Bit Position

The E5CN/AN/EN/GN does not support bit access. Fixed to "00."

## (3) Number of Elements

Number of elements		Processing
0000		The write operation is not performed (do not append write data to the service request PDU) and processing ends in "normal completion."
Double word (variable type C0, C1, or C3)	0001 to 0018 (1 to 24)	The write operation is performed and processing ends in a normal completion.
Word (variable type 80, 81, or 83)	0001 to 0030 (1 to 48)	

## (4) Response Code

## Normal Completion

Response code	Name	Description
0000	Normal completion	No errors were found.

## Error Occurred

Response code	Error name	Cause
1002	Command too short	The command is too short.
1101	Area type error	The variable type is wrong.
1103	Start address out-of-range error	Write start address is out of range.
1104	End address out-of-range error	The write end address (write start address + number of elements) exceeds the final address of the variable area.
1003	Number of elements/data mismatch	The number of data does not match the number of elements.
1100	Parameter error	<ul style="list-style-type: none"> <li>• Bit position is not "00."</li> <li>• The write data is out of the setting range.</li> </ul>
3003	Read-only error	Variable type "C0" was written to.
2203	Operation error	<ul style="list-style-type: none"> <li>• The Communications Writing parameter is set to "OFF" (disabled).</li> <li>• Attempted to write to a parameter in setup area 1 from setup area 0.</li> <li>• Attempted to write to a protect parameter from other than the protect level.</li> <li>• AT (auto-tuning) was in progress. (See note.)</li> <li>• EEPROM error</li> </ul>

Note: For details on AT (auto-tuning), refer to the *E5CN/E5AN/E5EN/E5GN Digital Temperature Controllers User's Manual Basic Type* (Cat. No. H156).

(5) Precautions

● Alarm Function

Even though alarms are not displayed on the Controller's display, they function normally in communications.

## ■ Composite Read from Variable Area

This service reads in order the contents of specified addresses in the variable area.

### Service Request PDU



### Service Response PDU

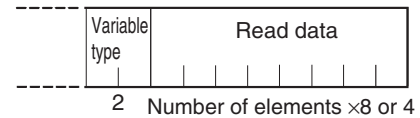
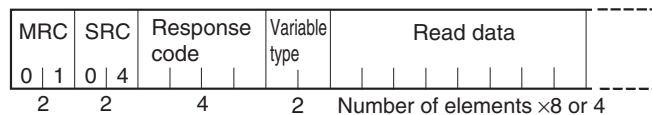

Note: The read data is read together with the variable type in the order specified by the command.

(1) Variable Type and Read Start Address

For details on variable types and read start addresses, see *SECTION 3 Communications Data for CompoWay/F and SYSWAY*.

(2) Bit Position

The E5CN/AN/EN/GN does not support bit access. Fixed to "00."

(3) Number of Read Data Items (Variable Type + Read Data + Bit Position Counted As 1 Item)

Read data length	Number of read data items
For double word (variable type C0, C1, or C3)	20 max.
For word (variable type 80, 81, or 83)	25 max.

Note: The following table gives the maximum number of read data items when double-word data and word data are used together.

Composite Read		Composite Read	
Double word (variable type C0, C1, or C3)	Word (variable type 80, 81, or 83)	Double word (variable type C0, C1, or C3)	Word (variable type 80, 81, or 83)
20	0	11	14
19	1	10	15
18	2	9	16
18	3	8	17
17	4	7	18
17	5	6	19
16	6	5	20
15	7	4	21
15	8	3	22
14	9	2	23
14	10	1	24
13	11	0	25
12	12		
12	13		

(4) Response Code  
Normal Completion

Response code	Name	Description
0000	Normal completion	No errors were found.

Error Occurred

Response code	Error name	Cause
1002	Command too short	The command is too short.
1101	Area type error	The variable type is wrong.
110B	Response too long	The number of elements exceeds the maximum.
1100	Parameter error	Bit position is not "00."
2203	Operation error	EEPROM error

## ■ Composite Write to Variable Area

This service writes in order the contents of specified addresses to a variable area.

## Service Request PDU

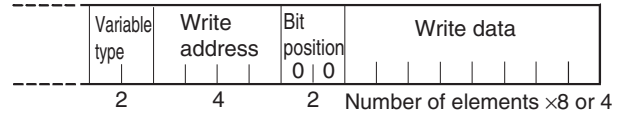
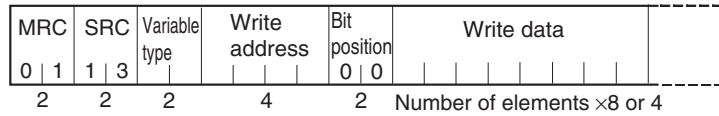

## Service Response PDU

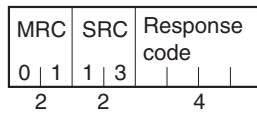

## (1) Variable Type and Write Start Address

For details on variable types and write start addresses, see *SECTION 3 Communications Data for CompoWay/F and SYSWAY*.

## (2) Bit Position

The E5CN/AN/EN/GN does not support bit access. Fixed to "00."

## (3) Number of Write Data Items (Variable Type + Write Address + Bit Position + Write Data Counted As 1 Item)

Write data length	Number of write data items
For double word (variable type C0, C1, or C3)	12 max.
For word (variable type 80, 81, or 83)	17 max.

Note: The following table gives the maximum number of write data items when double-word data and word data are used together.

Composite Write	
Double word (variable type C0, C1, or C3)	Word (variable type 80, 81, or 83)
12	0
12	1
11	2
10	3
9	4
9	5
8	6
7	7
6	8
6	9

Composite Write	
Double word (variable type C0, C1, or C3)	Word (variable type 80, 81, or 83)
5	10
4	11
3	12
3	13
2	14
1	15
0	16
0	17

(4) Response Code  
Normal Completion

Response code	Name	Description
0000	Normal completion	No errors were found.

Error Occurred

Response code	Error name	Cause
1002	Command too short	The command is too short.
1101	Area type error	The variable type is wrong.
1100	Parameter error	<ul style="list-style-type: none"> <li>• Bit position is not "00."</li> <li>• The write data is out of the setting range.</li> </ul>
3003	Read-only error	Variable type "C0" was written to.
2203	Operation error	<ul style="list-style-type: none"> <li>• The Communications Writing parameter is set to "OFF" (disabled).</li> <li>• Attempted to write to a parameter in setup area 1 from setup area 0.</li> <li>• Attempted to write to a protect parameter from other than the protect level.</li> <li>• AT (auto-tuning) was in progress. (See note.)</li> <li>• EEPROM error</li> </ul>

Note: For details on AT (auto-tuning), refer to the *E5CN/E5AN/E5EN/E5GN Digital Temperature Controllers User's Manual Basic Type* (Cat. No. H156).

## ■ Read Controller Attributes

This service reads the model number and communications buffer size.

### Service Request PDU

MRC	SRC
0   5	0   3
2	2

### Service Response PDU

MRC	SRC	Response code	Model No.	Buffer size
0   5	0   3			0   0   D   9
2	2	4	10	4

#### (1) Model Number

The model number is expressed in 10-byte ASCII. When 10 bytes are not required, pad the remaining bytes with spaces.

Example: The following model number is used for the E5CN-Q2HH03T (voltage output, two auxiliary outputs, two heater burnout detection inputs, communications functions, and TC/Pt universal input).

E	5	c	n	-	Q	2	H	H	O
---	---	---	---	---	---	---	---	---	---

Note: A lowercase “e” is applied to the E5AN/EN/GN (eg., e5an).

#### (2) Buffer Size

The communications buffer size is expressed in 2-byte hexadecimal, and read after being converted to 4-byte ASCII.

Buffer size: 217 bytes (= H'00D9)

#### (3) Response Code

Normal Completion

Response code	Name	Description
0000	Normal completion	No errors were found.

Error Occurred

Response code	Name	Description
1001	Command too long	The command is too long.
2203	Operation error	EEPROM error



**■ Read Controller Status**

This service reads the operating status and error status.

Service Request PDU

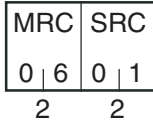

Service Response PDU

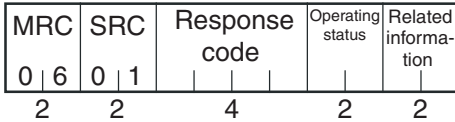

(1) Operating Status

Operating status	Description
00	Control is being carried out (error has not occurred in setup area 0 and the Controller is running).
01	Control is not being carried out (state other than above).

(2) Related Information

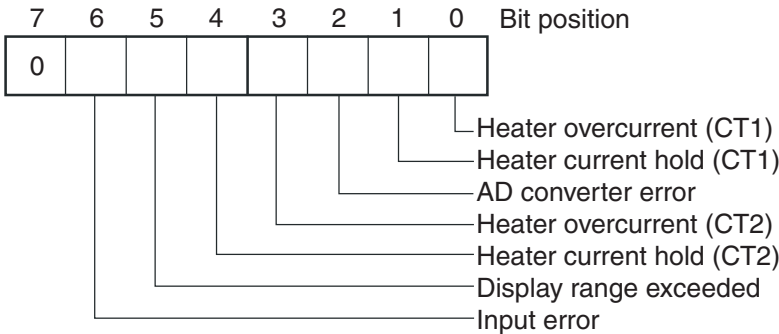

(3) Response Code

Normal Completion

Response code	Name	Description
0000	Normal completion	No errors were found.

Error Occurred

Response code	Name	Description
1001	Command too long	The command is too long.
2203	Operation error	EEPROM error

## ■ Echoback Test

This service performs an echoback test.

### Service Request PDU

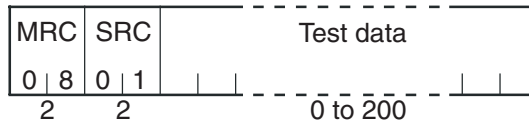

### Service Response PDU

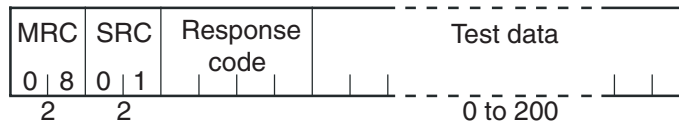

#### (1) Test Data

Set between 0 and 200 bytes of user-defined test data.

Set a value for the test data within the ranges shown below according to the communications data length.

Communications data length	Test Data
8 bits	ASCII data: H'20 to H'7E or H'A1 to H'FE
7 bits	ASCII data: H'20 to H'7E

Do not set the value H'40. No response will be returned.

#### (2) Response Code

Normal Completion

Response code	Name	Description
0000	Normal completion	No errors were found.

Error Occurred

Response code	Name	Description
1001	Command too long	The command is too long.
2203	Operation error	EEPROM error

## ■ Operation Command

This service performs operations such as the following:

- Communications Writing
- AT Execute/Cancel
- Software Reset
- Auto/Manual Switch
- Invert Direct/Reverse Operation
- RUN/STOP
- Write Mode
- Move to Setup Area 1
- Parameter Initialization
- Program Start
- Multi-SP
- Save RAM Data
- Move to Protect Level
- Alarm Latch Cancel

### Service Request PDU

MRC	SRC	Com- mand code	Related informa- tion
3   0	0   5		
2	2	2	2

### Service Response PDU

MRC	SRC	Response code
3   0	0   5	
2	2	4

(1) Command Code and Related Information

Command code	Command content	Related Information
00	Communications Writing	00: OFF (disabled) 01: ON (enabled)
01	RUN/STOP	00: Run 01: Stop
02	Multi-SP	00: Set point 0 01: Set point 1 02: Set point 2 03: Set point 3
03	AT Execute/Cancel	00: AT cancel 01: 100% AT execute 02: 40% AT execute
04	Write Mode	00: Backup mode 01: RAM write mode
05	Save RAM Data	00
06	Software Reset	00
07	Move to Setup Area 1	00
08	Move to Protect Level	00
09	Auto/Manual Switch	00: Automatic mode 01: Manual mode
0B	Parameter Initialization	00: Initialize to defaults

Command code	Command content	Related Information
0C	Alarm Latch Cancel	00: Alarm 1 latch cancel 01: Alarm 2 latch cancel 02: Alarm 3 latch cancel 03: HB alarm latch cancel 04: HS alarm latch cancel 05: OC alarm latch cancel 0F: All alarm latch cancel
0E	Invert Direct/Reverse Operation	00: Not invert 01: Invert
11	Program Start	00: Reset 01: Start

(2) Response Code  
Normal Completion

Response code	Name	Description
0000	Normal completion	No errors were found.

Error Occurred

Response code	Error name	Cause
1001	Command too long	The command is too long.
1002	Command too short	The command is too short.
1100	Parameter error	Command code and related information are wrong.
2203	Operation error	<ul style="list-style-type: none"> <li>The Communications Writing parameter is set to "OFF" (disabled). The command is received regardless of the Communications Writing parameter setting (ON/OFF).</li> <li>Processing could not be performed. For details, see (3) <i>Operation Commands and Precautions</i> below.</li> <li>EEPROM error</li> </ul>

(3) Operation Commands and Precautions

● Communications Writing

Set the Communications Writing parameter to "ON: enabled" or "OFF: disabled" with the related information setting. The setting can be accepted in both setup area 0 and setup area 1. An operation error will occur, however, if enabling or disabling communications writing is set for an event input.

#### ● RUN/STOP

Set control to “run” or “stop” with the related information setting. The setting can be accepted in both setup area 0 and setup area 1. An operation error will occur, however, if RUN/STOP is set for an event input.

#### ● Multi-SP

Set four set points beforehand in the adjustment level so that you can switch to a desired set point. The setting can be accepted in both setup area 0 and setup area 1. An operation error will occur in the following situations.

- When AT is being executed.
- When the Multi-SP Uses parameter is set to OFF.
- When the Multi-SP Uses parameter is set to ON but multi-SP is set for an event input (Number of Multi-SP Uses > 0).

#### ● AT Execute/Cancel

Set AT (auto-tuning) to “execute” or “cancel” with the related information setting. This command can be accepted in setup area 0 only. An “operation error” will be generated in the following instances:

- When the RUN/STOP parameter is set to “stop”
- When the command is executed in “setup area 1”
- When ON/OFF control is being used
- When 40% AT is specified during 100% AT execution.
- When 100% AT is specified during 40% AT execution.

In addition, a parameter error will occur if 40% AT is specified during heating and cooling control.

**Note:** If the same type of AT execution is specified during AT execution (e.g., if 100% AT is specified during 100% AT execution), the AT will not be restarted and the operation will end in normal completion with no processing.

#### ● Write Mode

Set either the backup mode or RAM write mode with the related information setting. The setting can be accepted in both setup area 0 and setup area 1.

The number of EEPROM (non-volatile memory) write operations is limited. Therefore, use RAM write mode when frequently overwriting data.

Write mode	Description
Backup mode	The data is written to EEPROM when the parameters in the operation/adjustment levels (excluding read-only parameters) are written by communications.

Write mode	Description
RAM write mode	The data is not written to EEPROM when the parameters in the operation/adjustment levels (excluding read-only parameters) are written by communications. Parameters can be changed by operating the keys on the front panel of the controller.

- When the mode is switched from RAM write mode to backup mode, the parameters in the operation/adjustment levels (excluding read-only parameters) are written to EEPROM.
- The RAM write mode is enabled only when the Communications Writing parameter is set to “ON” (enabled).  
Consequently, when the Communications Writing parameter setting is changed to “OFF” (disabled), the parameters in the operation/adjustment levels (excluding read-only parameters) are written to EEPROM even if the mode is set to RAM write mode.

● **Save RAM Data**

This command writes the parameters in the operation/adjustment levels (excluding read-only parameters) to EEPROM. The setting can be accepted in both setup area 0 and setup area 1.

● **Software Reset**

Restarts processing from the point when power is turned ON. The setting can be accepted in both setup area 0 and setup area 1.

● **Move to Setup Area 1**

This command moves to “setup area 1” and can be accepted at both setup areas 0 and 1. If the “initial setting/communications protect” is set to “2,” an “operation error” will be generated, and the move to setup area 1 will be prohibited.

When this move is carried out from setup area 0, the display indicates the Input Type parameter in the “initial setting level.” When this operation command is executed in setup area 1, the display will not change.

● **Move to Protect Level**

This command moves to the “protect level” and can be accepted only in setup area 0. When this command is issued in setup area 1, an “operation error” will be generated, and the move to the protect level will be prohibited.

◆ **Moving to Protect Level in Manual Mode**

When this operation command is issued in manual mode, an “operation error” will be generated, and the move to the protect level will be prohibited.

### ● Auto/Manual Switch

This operation command switches the mode to manual mode or automatic mode, based on the related information setting. This command can be accepted in setup area 0 only. An “operation error” will be generated in the following instances:

- When the command is executed in “setup area 1”
- When auto/manual switching is disabled (not displayed)

When the Controller is switched to manual mode, the “manual manipulated variable” will be displayed. When the Controller is switched from manual mode to automatic mode, the operation level’s first parameter will be displayed. When the Controller is switched to manual mode while already in manual mode, the command will be completed normally and the display will not change (the contents will not be refreshed).

### ◆ Writing Auto/Manual Status in EEPROM

The write mode determines whether the auto/manual status is written to EEPROM.

Write mode	Description
Backup mode	When the auto/manual mode is switched by communications, the auto/manual status is written to EEPROM.
RAM write mode	When the auto/manual mode is switched by communications, the auto/manual status is not written to EEPROM. The status can be written with the Controller key operation.

**Note:** When the auto/manual mode is switched with an operation command through communications and the Controller is in RAM write mode, the auto/manual status is not stored in EEPROM. Consequently, if the Controller is restarted by performing a software reset or turning the power OFF and ON again, the auto/manual mode is set to the last saved status.

### ◆ Switching to Manual Mode during Auto-tuning

If the mode is switched during auto-tuning (AT), the AT will be cancelled and the Controller will be switched to manual mode.

### ● Parameter Initialization

The present settings are returned to the default values and written to EEPROM. This command can be accepted in setup area 1 only. When this command is issued in setup area 0, an “operation error” will be generated.

### ● Alarm Latch Cancel

Related information	Explanation (initialization values)
00	Default initialization values (See <i>SECTION 3 Communications Data for CompoWay/F and SYSWAY</i> for details.) (These settings are the same as the ones used when “FACT” is selected for the setting data’s set value initialization.)

The applicable alarm latch can be cleared with the related information setting. The setting can be accepted in both setup area 0 and setup area 1. An operation error will occur if communications writing is disabled or if an EEPROM error occurs.

#### ● Invert Direct/Reverse Operation

Inverting or not inverting direct/reverse operation can be selected with the related information setting. The setting can be accepted in both setup area 0 and setup area 1. The related information specifications are written to EEPROM according to the write mode settings. An operation error will occur in the following situations:

- When AT is being executed.
- When inverting direct/reverse operation is set for an event input.
- When executed in manual mode.

#### ● Program Start

The simple program function can be reset/started with the related information setting. The setting can be accepted in both setup area 0 and setup area 1. An operation error will be generated if program start has been set in the event input.

#### ● Setting Areas

Control operation is executed in setting area 0. In this state, you can perform operations that are permitted only during control or those that cause no problems even if control is in progress. These operations include reading PVs, writing SPs, and change RUN/STOP status.

Setting area 0, however, prohibits operations that affect control, including writing data at the initial setting level. (Reading setting data is always allowed.)

In setting area 1, control operation is stopped. In this state, you can perform operations that are not allowed in setting area 0. These operations include writing data at the initial setting level.

At power-ON, the Temperature Controller is set in setting area 0. To move to setting area 1, use the “move-to-setting area 1” command. To return to setting area 0, turn the power OFF and ON again, or use the “software reset” command.



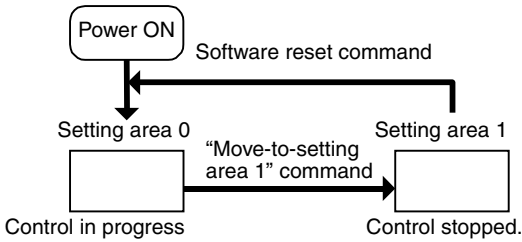

## 2.4 Response Code List

### Normal Completion

Response code	Name	Description	Error detection priority
0000	Normal completion	No errors were found.	None

### Error Occurred

Response code	Name	Description	Error detection priority
0401	Unsupported command	The service function for the relevant command is not supported.	1
1001	Command too long	The command is too long.	2
1002	Command too short	The command is too short.	3
1101	Area type error	Wrong variable type	4
1103	Start address out-of-range error	The read/write start address is out of range.	5
1104	End address out-of-range error	The write end address (write start address + number of elements) exceeds the final address of the variable area.	6
1003	Number of elements/data mismatch	The amount of data does not match the number of elements.	7
110B	Response too long	The response length exceeds the communications buffer size (when the number of elements is greater than the maximum number of elements for that service).	8
1100	Parameter error	<ul style="list-style-type: none"> <li>• Bit position is not "00."</li> <li>• The write data is out of the setting range.</li> <li>• The command code or related information in the operation command is wrong.</li> </ul>	9
3003	Read-only error	Variable type "C0" was written to.	10
2203	Operation error	<ul style="list-style-type: none"> <li>• The Communications Writing parameter is set to "OFF" (disabled).</li> <li>• Attempted to write to a parameter in setup area 1 from setup area 0.</li> <li>• Attempted to write to a protect parameter from other than the protect level.</li> <li>• Writing was carried out during AT execution.</li> <li>• Processing is not possible by operation command.</li> <li>• EEPROM error</li> </ul>	11

# SECTION 3

## Communications Data for CompoWay/F and SYSWAY

This section lists the details of the communications data in the CompoWay/F and SYSWAY communications protocols.

3.1	Variable Area (Setting Range) List .....	3-2
3.2	Status and Status 2 .....	3-15
	Status Structure .....	3-15
	Status 2 Structure .....	3-17
	Status Details .....	3-18
	Status 2 Details .....	3-19

### 3.1 Variable Area (Setting Range) List

For communications using a variable type not enclosed in parentheses in the following table, the set value is double-word data (8 digits). For communications using a variable type enclosed in parentheses, the set value is single-word data (4 digits).

For example, variable type C0 is double-word data (8 digits), and variable type 80 is single-word data (4 digits).

Items expressed in hexadecimal in the “Set (monitor) value” column are the setting range for CompoWay/F communications. The values in parentheses are the actual setting range. Use the values in parentheses as the setting range for SYSWAY communications. When there is a section reference for a setting item, refer to that reference for details.

Variable type	Address	Parameter name	Setting (monitor) value	Level	
C0 (80)	0000	PV	Temperature: Use the specified range for each sensor. Analog: Scaling lower limit –5% FS to Scaling upper limit +5% FS	Operation	
C0 (80)	0001	Status (See notes 1 and 2.)	See 3.2 Status and Status 2 for details.		
C0 (80)	0002	Internal Set Point (See note 1.)	SP lower limit to SP upper limit		
C0 (80)	0003	Heater Current 1 Value Monitor	H'00000000 to H'00000226 (0.0 to 55.0)		
C0 (80)	0004	MV Monitor (Heating)	Standard: H'FFFFFFCE to H'0000041A (–5.0 to 105.0) Heating and cooling: H'00000000 to H'0000041A (0.0 to 105.0)		
C0 (80)	0005	MV Monitor (Cooling)	H'00000000 to H'0000041A (0.0 to 105.0)		
C0 (80)	0006	Heater Current 2 Value Monitor	H'00000000 to H'00000226 (0.0 to 55.0)		
C0 (80)	0007	Leakage Current 1 Monitor	H'00000000 to H'00000226 (0.0 to 55.0)		
C0 (80)	0008	Leakage Current 2 Monitor	H'00000000 to H'00000226 (0.0 to 55.0)		
C0 (80)	0009	Soak Time Remain	H'00000000 to H'0000270F (0 to 9999)		
C0 (80)	000C	Multi-SP Monitor	H'00000000 to H'00000003 (0 to 3)		
C0 (80)	000E	Decimal Point Monitor (See note 1.)	H'00000000 to H'00000003 (0 to 3)		
C0 (80)	000F	Control Output 1 ON/OFF Count Monitor	H'00000000 to H'0000270F (0 to 9999)		Advanced function setting
C0 (80)	0010	Control Output 2 ON/OFF Count Monitor	H'00000000 to H'0000270F (0 to 9999)		
C0 (80)	0011	Status 2 (See notes 1 and 2.)	Refer to 3.2 Status and Status 2.	Operation	
C0 (80)	0012	Status (See notes 1 and 3.)	Refer to 3.2 Status and Status 2.		
C0 (80)	0013	Status 2 (See notes 1 and 3.)	Refer to 3.2 Status and Status 2.		

Note 1: Not displayed on the Controller display.

Note 2: When the variable type is 80 (word access), the rightmost 16 bits are read.

Note 3: When the variable type is 80 (word access), the leftmost 16 bits are read.

Variable type	Address	Parameter name	Setting (monitor) value	Level
C1 (81)	0000	Operation/Adjustment Protect	H'00000000 (0): No restrictions in operation and adjustment levels H'00000001 (1): Move to adjustment level is prohibited. H'00000002 (2): Display and change of only "PV" and "PV/SP" parameters is allowed. H'00000003 (3): Display of only "PV" and "PV/SP" parameters is allowed.	Protect
C1 (81)	0001	Initial Setting/Communications Protect	H'00000000 (0): Move to initial setting/communications setting level is allowed. (Move to advanced function setting level is displayed.) H'00000001 (1): Move to initial setting/communications setting level is allowed. (Move to advanced function setting level is not displayed.) H'00000002 (2): Move to initial setting/communications setting level is prohibited.	
C1 (81)	0002	Setting Change Protect	H'00000000 (0): OFF (Changing of setup on Controller display is allowed.) H'00000001 (1): ON (Changing of setup on Controller display is prohibited.)	
C1 (81)	0003	Set Point	SP lower limit to SP upper limit	Operation
C1 (81)	0004	Alarm Value 1	H'FFFFFF831 to H'0000270F (-1999 to 9999)	
C1 (81)	0005	Alarm Value Upper Limit 1	H'FFFFFF831 to H'0000270F (-1999 to 9999)	
C1 (81)	0006	Alarm Value Lower Limit 1	H'FFFFFF831 to H'0000270F (-1999 to 9999)	
C1 (81)	0007	Alarm Value 2	H'FFFFFF831 to H'0000270F (-1999 to 9999)	
C1 (81)	0008	Alarm Value Upper Limit 2	H'FFFFFF831 to H'0000270F (-1999 to 9999)	
C1 (81)	0009	Alarm Value Lower Limit 2	H'FFFFFF831 to H'0000270F (-1999 to 9999)	
C1 (81)	000A	Alarm Value 3 (See note 1.)	H'FFFFFF831 to H'0000270F (-1999 to 9999)	
C1 (81)	000B	Alarm Value Upper Limit 3 (See note 1.)	H'FFFFFF831 to H'0000270F (-1999 to 9999)	
C1 (81)	000C	Alarm Value Lower Limit 3 (See note 1.)	H'FFFFFF831 to H'0000270F (-1999 to 9999)	
C1 (81)	000D	Heater Burnout Detection 1	H'00000000 to H'000001F4 (0.0 to 50.0)	Adjustment
C1 (81)	000E	SP 0	SP lower limit to SP upper limit	
C1 (81)	000F	SP 1	SP lower limit to SP upper limit	
C1 (81)	0010	SP 2	SP lower limit to SP upper limit	
C1 (81)	0011	SP 3	SP lower limit to SP upper limit	
C1 (81)	0012	Temperature Input Shift	H'FFFFFF831 to H'0000270F (-199.9 to 999.9)	
C1 (81)	0013	Upper Limit Temperature Input Shift Value	H'FFFFFF831 to H'0000270F (-199.9 to 999.9)	
C1 (81)	0014	Lower Limit Temperature Input Shift Value	H'FFFFFF831 to H'0000270F (-199.9 to 999.9)	

Note: The alarm function can also be used in Controllers without alarm output terminals. In this case, confirm alarm occurrences via the status data.

Note 1: Not displayed on the Controller display when Alarm 3 is not assigned to an output.

SECTION 3 Communications Data for CompoWay/F and SYSWAY

Variable type	Address	Parameter name	Setting (monitor) value	Level
C1 (81)	0015	Proportional Band	H'00000001 to H'0000270F (0.1 to 999.9)	Adjustment
C1 (81)	0016	Integral Time	H'00000000 to H'00000F9F (0 to 3999)	
C1 (81)	0017	Derivative Time	H'00000000 to H'00000F9F (0 to 3999) (Range when RT is "OFF") H'00000000 to H'0000270F (0.0 to 999.9) (Range when RT is "ON")	
C1 (81)	0018	Cooling Coefficient	H'00000001 to H'0000270F (0.01 to 99.99)	
C1 (81)	0019	Dead Band	H'FFFFFF831 to H'0000270F (-199.9 to 999.9 for TC/Pt universal input models) (-19.99 to 99.99 for Analog input models)	
C1 (81)	001A	Manual Reset Value	H'00000000 to H'000003E8 (0.0 to 100.0)	
C1 (81)	001B	Hysteresis (Heating)	H'00000001 to H'0000270F (0.1 to 999.9 for TC/Pt universal input models) (0.01 to 99.99 for Analog input models)	
C1 (81)	001C	Hysteresis (Cooling)	H'00000001 to H'0000270F (0.1 to 999.9 for TC/Pt universal input models) (0.01 to 99.99 for Analog input models)	
C1 (81)	001D	Heater Burnout Detection 2	H'00000000 to H'000001F4 (0.0 to 50.0)	
C1 (81)	001E	HS Alarm 1	H'00000000 to H'000001F4 (0.0 to 50.0)	
C1 (81)	001F	HS Alarm 2	H'00000000 to H'000001F4 (0.0 to 50.0)	
C1 (81)	0020	Soak Time	H'00000001 to H'0000270F (1 to 9999)	
C1 (81)	0021	Wait Band	H'00000000 (0): OFF H'00000001 to H'0000270F (0.1 to 999.9 for TC/Pt universal input models) (0.01 to 99.99 for Analog input models)	
C1 (81)	0022	MV at Stop	Standard: H'FFFFFFCE to H'0000041A (-5.0 to 105.0) Heating and cooling: H'FFFFFFBE6 to H'0000041A (-105.0 to 105.0)	
C1 (81)	0023	MV at PV Error	Standard: H'FFFFFFCE to H'0000041A (-5.0 to 105.0) Heating and cooling: H'FFFFFFBE6 to H'0000041A (-105.0 to 105.0)	
C1 (81)	0024	Manual MV	Standard: H'FFFFFFCE to H'0000041A (-5.0 to 105.0) Heating and cooling: H'FFFFFFBE6 to H'0000041A (-105.0 to 105.0)	
C1 (81)	0025	SP Ramp Set Value	H'00000000 (0): OFF H'00000001 to H'0000270F (1 to 9999)	Adjustment
C1 (81)	0026	MV Upper Limit	Standard: MV lower limit + 0.1 to H'0000041A (MV lower limit + 0.1 to 105.0) Heating and cooling: H'00000000 to H'0000041A (0.0 to 105.0)	
C1 (81)	0027	MV Lower Limit	Standard: H'FFFFFFCE to MV upper limit - 0.1 (-5.0 to MV upper limit - 0.1) Heating and cooling: H'FFFFFFBE6 to H'00000000 (-105.0 to 0.0)	

Com Data for CompoWay/F

Variable type	Address	Parameter name	Setting (monitor) value	Level
C1 (81)	0028	Move to Protect Level	H'FFFFFF831 to H'0000270F (-1999 to 9999)	Protect
C1 (81)	0029	Password to Move to Protect Level	H'FFFFFF831 to H'0000270F (-1999 to 9999) (Can only be set. The monitor value is always H'00000000.)	
C1 (81)	002A	Parameter Mask Enable	H'00000000 (0): OFF H'00000001 (1): ON	
C1 (81)	002B	PF Key Protect	H'00000000 (0): OFF H'00000001 (1): ON	
C1 (81)	002C	MV Change Rate Limit	H'00000000 to H'000003E8 (0.0 to 100.0)	Adjustment
C1 (81)	002F	Heater Overcurrent Detection 1	H'00000000 to H'000001F4 (0.0 to 50.0)	
C1 (81)	0030	Heater Overcurrent Detection 2	H'00000000 to H'000001F4 (0.0 to 50.0)	
C1 (81)	0031	Extraction of Square Root Low-cut Point	H'00000000 to H'000003E8 (0.0 to 100.0)	
C3 (83)	0000	Input Type (Controllers with TC/Pt universal input) (See note.)	H'00000000 (0): Pt (-200 to 850°C/-300 to 1500°F) H'00000001 (1): Pt (-199.9 to 500.0°C/-199.9 to 900.0°F) H'00000002 (2): Pt (0.0 to 100.0°C/0.0 to 210.0°F) H'00000003 (3): JPt (-199.9 to 500.0°C/-199.9 to 900.0°F) H'00000004 (4): JPt (0.0 to 100.0°C/0.0 to 210.0°F) H'00000005 (5): K (-200 to 1300°C/-300 to 2300°F) H'00000006 (6): K (-20.0 to 500.0°C/0.0 to 900.0°F) H'00000007 (7): J (-100 to 850°C/-100 to 1500°F) H'00000008 (8): J (-20.0 to 400.0°C/0.0 to 750.0°F) H'00000009 (9): T (-200 to 400°C/-300 to 700°F) H'0000000A (10): T (-199.9 to 400.0°C/-199.9 to 700.0°F) H'0000000B (11): E (-200 to 600°C/-300 to 1100°F) H'0000000C (12): L (-100 to 850°C/-100 to 1500°F) H'0000000D (13): U (-200 to 400°C/-300 to 700°F) H'0000000E (14): U (-199.9 to 400.0°C/-199.9 to 700.0°F) H'0000000F (15): N (-200 to 1300°C/-300 to 2300°F) H'00000010 (16): R (0 to 1700°C/0 to 3000°F) H'00000011 (17): S (0 to 1700°C/0 to 3000°F) H'00000012 (18): B (100 to 1800°C/300 to 3200°F) H'00000013 (19): Infrared temperature sensor (K 140°F/60°C) H'00000014 (20): Infrared temperature sensor (K 240°F/120°C) H'00000015 (21): Infrared temperature sensor (K 280°F/140°C) H'00000016 (22): Infrared temperature sensor (K 440°F/220°C) H'00000017 (23): 0 to 50 mV H'00000018 (24): W (0 to 2300°C/0 to 3200°F) H'00000019 (25): PL II (0 to 1300°C/0 to 2300°F)	Initial setting

Note: The input type can be selected to match the connected sensor.

There are two input type specifications: Thermocouple/Resistance thermometer input and Analog input.

Variable type	Address	Parameter name	Setting (monitor) value	Level
C3 (83)	0000	Input Type (analog input models) (See note.)	H'00000000 (0): 4 to 20 mA H'00000001 (1): 0 to 20 mA H'00000002 (2): 1 to 5 V H'00000003 (3): 0 to 5 V H'00000004 (4): 0 to 10 V	Initial setting
C3 (83)	0001	Scaling Upper Limit	Scaling lower limit + 1 to H'0000270F (scaling lower limit + 1 to 9,999)	
	0002	Scaling Lower Limit	H'FFFFFF831 to Scaling upper limit - 1 (-1999 to Scaling upper limit - 1)	
	0003	Decimal Point (TC/Pt universal input models)	H'00000000 to 00000001 (0 to 1)	
		Decimal Point (analog input models)	H'00000000 to 00000003 (0 to 3)	
C3 (83)	0004	Temperature Unit	H'00000000 (0): °C H'00000001 (1): °F	
C3 (83)	0005	SP Upper Limit	The range of values (without decimal point) is as follows: Temperature: SP lower limit + 1 to Input range upper limit Analog: SP lower limit + 1 to Scaling upper limit	
C3 (83)	0006	SP Lower Limit	The range of values (without decimal point) is as follows: Temperature: Input range lower limit to SP upper limit - 1 Analog: Scaling lower limit to SP upper limit - 1	
C3 (83)	0007	PID ON/OFF	H'00000000 (0): ON/OFF H'00000001 (1): 2 PID control	
C3 (83)	0008	Standard or Heating/Cooling	H'00000000 (0): Standard H'00000001 (1): Heating and cooling	
C3 (83)	0009	ST	H'00000000 (0): OFF H'00000001 (1): ON	
C3 (83)	000A	Control Period (Heating)	H'00000000 (0): 0.5 H'00000001 to H'00000063 (1 to 99)	
C3 (83)	000B	Control Period (Cooling)	H'00000000 (0): 0.5 H'00000001 to H'00000063 (1 to 99)	
C3 (83)	000C	Direct/Reverse Operation	H'00000000 (0): Reverse operation H'00000001 (1): Direct operation	

Note: The input type can be selected to match the connected sensor.

There are two input type specifications: Thermocouple/Resistance thermometer input and Analog input.



Variable type	Address	Parameter name	Setting (monitor) value	Level
C3 (83)	000D	Alarm 1 Type	H'00000000 (0): Alarm function OFF H'00000001 (1): Upper and lower-limit alarm H'00000002 (2): Upper-limit alarm H'00000003 (3): Lower-limit alarm H'00000004 (4): Upper and lower-limit range alarm H'00000005 (5): Upper and lower-limit alarm with standby sequence H'00000006 (6): Upper-limit alarm with standby sequence H'00000007 (7): Lower-limit alarm with standby sequence H'00000008 (8): Absolute-value upper-limit alarm H'00000009 (9): Absolute-value lower-limit alarm H'0000000A (10): Absolute-value upper-limit alarm with standby sequence H'0000000B (11): Absolute-value lower-limit alarm with standby sequence H'0000000C (12): LBA (Loop Burnout Alarm) H'0000000D (13): PV change rate alarm	Initial setting
C3 (83)	000E	Alarm 2 Type	H'00000000 (0): Alarm function OFF H'00000001 (1): Upper and lower-limit alarm H'00000002 (2): Upper-limit alarm H'00000003 (3): Lower-limit alarm H'00000004 (4): Upper and lower-limit range alarm H'00000005 (5): Upper and lower-limit alarm with standby sequence H'00000006 (6): Upper-limit alarm with standby sequence H'00000007 (7): Lower-limit alarm with standby sequence H'00000008 (8): Absolute-value upper-limit alarm H'00000009 (9): Absolute-value lower-limit alarm H'0000000A (10): Absolute-value upper-limit alarm with standby sequence H'0000000B (11): Absolute-value lower-limit alarm with standby sequence H'0000000C (12): No alarm function H'0000000D (13): PV change rate alarm	
C3 (83)	000F	Alarm 3 Type (See note 1.)	Same settings as the alarm 2 type	
C3 (83)	0010	Communications Unit No. (See note 2.)	H'00000000 to H'00000063 (0 to 99)	Communications setting
C3 (83)	0011	Communications Baud Rate (See note 2.)	H'00000000 (0): 1.2 H'00000001 (1): 2.4 H'00000002 (2): 4.8 H'00000003 (3): 9.6 H'00000004 (4): 19.2 H'00000005 (5): 38.4 H'00000006 (6): 57.6	
C3 (83)	0012	Communications Data Length (See note 2.)	H'00000007 (7): 7 H'00000008 (8): 8	
C3 (83)	0013	Communications Stop Bits (See note 2.)	H'00000001 (1): 1 H'00000002 (2): 2	
C3 (83)	0014	Communications Parity (See note 2.)	H'00000000 (0): None H'00000001 (1): Even H'00000002 (2): Odd	
C3 (83)	0015	Number of Multi-SP Uses	H'00000000 (0): No multi-SP H'00000001 (1): 2SP H'00000002 (2): 4SP	Initial setting

Note: The alarm function can also be used in Controllers without alarm output terminals. In this case, confirm alarm occurrences via the status data.

Note 1: Not displayed on the Controller display when Alarm 3 is not assigned to the output.

Note 2: After communications parameters have been changed, reset the Controller to enable them.

Variable type	Address	Parameter name	Setting (monitor) value	Level
C3 (83)	0016	Event Input Assignment 1 (See note 1.)	H'00000000 (0): None H'00000001 (1): RUN/STOP H'00000002 (2): Auto/manual switch H'00000003 (3): Program Start (See note 3.) H'00000004 (4): Direct/reverse operation H'00000005 (5): None H'00000006 (6): 100% AT execute/cancel H'00000007 (7): 40% AT execute/cancel H'00000008 (8): Setting change enable/disable H'00000009 (9): Communications writing enable/disable H'0000000A (10): Alarm latch cancel	Initial setting
C3 (83)	0017	Event Input Assignment 2 (See note 2.)	H'00000000 to H'0000000A (0 to 10) * Same as for Event Input Assignment 1.	
C3 (83)	0018	Event Input Assignment 3	H'00000000 to H'0000000A (0 to 10) * Same as for Event Input Assignment 1.	
C3 (83)	0019	Event Input Assignment 4	H'00000000 to H'0000000A (0 to 10) * Same as for Event Input Assignment 1.	
C3 (83)	001A	Multi-SP Uses	H'00000000 (0): OFF H'00000001 (1): ON	Advanced function setting
C3 (83)	001B	SP Ramp Time Unit	H'00000000 (0): EU/second H'00000001 (1): EU/minute H'00000002 (2): EU/hour	
C3 (83)	001C	SP Ramp Set Value	H'00000000 (0): OFF H'00000001 to H'0000270F (1 to 9999)	Adjustment
C3 (83)	001D	Standby Sequence Reset	H'00000000 (0): Condition A H'00000001 (1): Condition B	
C3 (83)	001E	Auxiliary Output 1 Open in Alarm	H'00000000 (0): Close in alarm H'00000001 (1): Open in alarm	Advanced function setting
C3 (83)	001F	Alarm 1 Hysteresis	H'00000001 to H'0000270F (0.1 to 999.9 for TC/Pt universal input models) (0.01 to 99.99 for Analog input models)	Initial setting

Note 1: For Controllers with two event inputs (events 1 and 2), this cannot be set if the Number of Multi-SP Uses parameter is set to 1 or 2.

Note 2: For Controllers with two event inputs (events 1 and 2), this cannot be set if the Number of Multi-SP Uses parameter is set to 2.

Note 3: PRST (program start) can be set even when the program pattern is set to OFF, but the function will be disabled.

Variable type	Address	Parameter name	Setting (monitor) value	Level
C3 (83)	0020	Auxiliary Output 2 Open in Alarm	H'00000000 (0): Close in alarm H'00000001 (1): Open in alarm	Advanced function setting
C3 (83)	0021	Alarm 2 Hysteresis	H'00000001 to H'0000270F (0.1 to 999.9 for TC/Pt universal input models) (0.01 to 99.99 for Analog input models)	Initial setting
C3 (83)	0022	Auxiliary Output 3 Open in Alarm (See note 1.)	H'00000000 (0): Close in alarm H'00000001 (1): Open in alarm	Advanced function setting
C3 (83)	0023	Alarm 3 Hysteresis (See note 1.)	H'00000001 to H'0000270F (0.1 to 999.9 for TC/Pt universal input models) (0.01 to 99.99 for Analog input models)	Initial setting
C3 (83)	0024	HB ON/OFF	H'00000000 (0): OFF H'00000001 (1): ON	Advanced function setting
C3 (83)	0025	Heater Burnout Latch	H'00000000 (0): OFF H'00000001 (1): ON	Advanced function setting
C3 (83)	0026	Heater Burnout Hysteresis	H'00000001 to H'000001F4 (0.1 to 50.0)	
C3 (83)	0027	ST Stable Range	H'00000001 to H'0000270F (0.1 to 999.9)	
C3 (83)	0028	$\alpha$	H'00000000 to H'00000064 (0.00 to 1.00)	
C3 (83)	0029	MV Upper Limit	Standard: MV lower limit + 0.1 to H'0000041A (MV lower limit + 0.1 to 105.0) Heating and cooling: H'00000000 to H'0000041A (0.0 to 105.0)	
C3 (83)	002A	MV Lower Limit	Standard: H'FFFFFFCE to MV upper limit - 0.1 (-5.0 to MV upper limit - 0.1) Heating and cooling: H'FFFFFFBE6 to H'00000000 (-105.0 to 0.0)	
C3 (83)	002B	Input Digital Filter	H'00000000 to H'0000270F (0.0 to 999.9)	Advanced function setting
C3 (83)	002C	Additional PV Display	H'00000000 (0): OFF H'00000001 (1): ON	
C3 (83)	002D	MV Display	H'00000000 (0): OFF (display of manipulated variable OFF) H'00000001 (1): ON (display of manipulated variable ON)	
C3 (83)	002E	Automatic Display Return Time	H'00000000 (0): OFF H'00000001 to H'00000063 (1 to 99)	
C3 (83)	002F	Alarm 1 Latch	H'00000000 (0): OFF H'00000001 (1): ON	
C3 (83)	0030	Alarm 2 Latch	H'00000000 (0): OFF H'00000001 (1): ON	
C3 (83)	0031	Alarm 3 Latch (See note 1.)	H'00000000 (0): OFF H'00000001 (1): ON	
C3 (83)	0032	Move to Protect Level Time	H'00000001 to H'0000001E (1 to 30)	
C3 (83)	0033	Input Error Output	H'00000000 (0): OFF H'00000001 (1): ON	
C3 (83)	0034	Cold Junction Compensation Method	H'00000000 (0): OFF H'00000001 (1): ON	
C3 (83)	0035	MB Command Logic Switching (See note 2.)	H'00000000 (0): OFF H'00000001 (1): ON	

Note: The alarm function can also be used in Controllers without alarm output terminals. In this case, confirm alarm occurrences via the status data.

Note 1: Not displayed on the Controller display when Alarm 3 is not assigned to the output.

Note 2: The logic is switched only in the MB command (SYSWAY). The logic of CompoWay/F operation command code 00 (communications writing) is not affected.

Variable type	Address	Parameter name	Setting (monitor) value	Level	
C3 (83)	0036	PV Change Color	H'00000000 (0): Orange H'00000001 (1): Red H'00000002 (2): Green H'00000003 (3): Red to green: When ALM1 is ON H'00000004 (4): Green to red: When ALM1 is ON H'00000005 (5): Red to green to red: Within PV stable band: Green Outside stable band: Red H'00000006 (6): Green to orange to red: Within PV stable band: Orange Outside stable band: Green, red H'00000007 (7): Orange to green to red: Within PV stable band: Green Outside stable band: Orange, red	Advanced function setting	
C3 (83)	0037	PV Stable Band	H'00000001 to H'0000270F (0.1 to 999.9 for TC/Pt universal input models) (0.01 to 99.99 for Analog input models)		
C3 (83)	0038	Alarm 1 ON Delay	H'00000000 to H'000003E7 (0 to 999)		
C3 (83)	0039	Alarm 2 ON Delay	H'00000000 to H'000003E7 (0 to 999)		
C3 (83)	003A	Alarm 3 ON Delay (See note 1.)	H'00000000 to H'000003E7 (0 to 999)		
C3 (83)	003B	Alarm 1 OFF Delay	H'00000000 to H'000003E7 (0 to 999)		
C3 (83)	003C	Alarm 2 OFF Delay	H'00000000 to H'000003E7 (0 to 999)		
C3 (83)	003D	Alarm 3 OFF Delay (See note 1.)	H'00000000 to H'000003E7 (0 to 999)		
C3 (83)	003E	Transfer Output Type	H'00000000 (0): OFF H'00000001 (1): Set point H'00000002 (2): Set point during SP ramp H'00000003 (3): PV H'00000004 (4): MV monitor (heating) H'00000005 (5): MV monitor (cooling)		Initial setting
C3 (83)	003F	Transfer Output Upper Limit	H'FFFFFF831 to H'0000270F (-1999 to 9999) (See note 2.)		
C3 (83)	0040	Transfer Output Lower Limit	H'FFFFFF831 to H'0000270F (-1999 to 9999) (See note 2.)		
C3 (83)	0041	Linear Current Output	H'00000000 (0): 4 to 20 mA H'00000001 (1): 0 to 20 mA		
C3 (83)	0042	Input Shift Type	H'00000000 (0): Temperature input 1-point shift H'00000001 (1): Temperature input 2-point shift		
C3 (83)	0043	MV at Stop and Error Addition	H'00000000 (0): OFF H'00000001 (1): ON		
C3 (83)	0044	Auto/Manual Select Addition	H'00000000 (0): OFF H'00000001 (1): ON	Advanced function setting	
C3 (83)	0045	RT	H'00000000 (0): OFF H'00000001 (1): ON		
C3 (83)	0046	HS Alarm Use	H'00000000 (0): OFF H'00000001 (1): ON		
C3 (83)	0047	HS Alarm Latch	H'00000000 (0): OFF H'00000001 (1): ON		
C3 (83)	0048	HS Alarm Hysteresis	H'00000001 to H'000001F4 (0.1 to 50.0)		
C3 (83)	0049	LBA Detection Time	H'00000000 to H'0000270F (0 to 9999)		
C3 (83)	004A	LBA Level	H'00000001 to H'0000270F (0.1 to 999.9 for TC/Pt universal input models) (0.01 to 99.99 for Analog input models)		
C3 (83)	004B	LBA Band	H'00000000 to H'0000270F (0.0 to 999.9 for TC/Pt universal input models) (0.00 to 99.99 for Analog input models)		

Note 1: Not displayed on the Controller display when Alarm 3 is not assigned to the output.

Note 2: The setting (monitor) range depends on the transfer output type setting. (Refer to *Section 5 Parameters* in the *E5CN/E5AN/E5EN/E5GN Digital Temperature Controllers User's Manual Basic Type* (Cat. No. H156).)

Variable type	Address	Parameter name	Setting (monitor) value	Level
C3 (83)	004C	Protocol Setting (See note 1.)	H'00000000 (0): CompoWay/F (SYSWAY) H'00000001 (1): Modbus	Communications setting
C3 (83)	004D	Send Data Wait Time (See note 1.)	H'00000000 to H'00000063 (0 to 99)	
C3 (83)	004E	Control Output 1 Assignment	When control output 1 is a linear output: H'00000000 (0): Not assigned. H'00000001 (1): Control output (heating) H'00000002 (2): Control output (cooling) When control output 1 is an ON/OFF output: H'00000000 (0): Not assigned. H'00000001 (1): Control output (heating) H'00000002 (2): Control output (cooling) H'00000003 (3): Alarm 1 H'00000004 (4): Alarm 2 H'00000005 (5): Alarm 3 H'00000006 (6): Program end output (See note 2.) H'00000007 (7): Control output ON/OFF count alarm (See note 3.) H'00000008 (8): Work bit 1 H'00000009 (9): Work bit 2 H'0000000A (10): Work bit 3 H'0000000B (11): Work bit 4 H'0000000C (12): Work bit 5 H'0000000D (13): Work bit 6 H'0000000E (14): Work bit 7 H'0000000F (15): Work bit 8	Advanced function setting
C3 (83)	004F	Control Output 2 Assignment	H'00000000 (0): Not assigned. H'00000001 (1): Control output (heating) H'00000002 (2): Control output (cooling) H'00000003 (3): Alarm 1 H'00000004 (4): Alarm 2 H'00000005 (5): Alarm 3 H'00000006 (6): Program end output (See note 2.) H'00000007 (7): Control output ON/OFF count alarm (See note 3.) H'00000008 (8): Work bit 1 H'00000009 (9): Work bit 2 H'0000000A (10): Work bit 3 H'0000000B (11): Work bit 4 H'0000000C (12): Work bit 5 H'0000000D (13): Work bit 6 H'0000000E (14): Work bit 7 H'0000000F (15): Work bit 8	

Note 1: After communications parameters have been changed, reset the Controller to enable them.

Note 2: P.END (program end output) can be set even when the program pattern is set to OFF, but the function will be disabled.

Note 3: The output turns ON when the status of either the Control Output 1 ON/OFF Count Alarm or the Control Output 2 ON/OFF Count Alarm turns ON.

Variable type	Address	Parameter name	Setting (monitor) value	Level
C3 (83)	0050	Auxiliary Output 1 Assignment	H'00000000 (0): Not assigned. H'00000001 (1): Control output (heating) H'00000002 (2): Control output (cooling) H'00000003 (3): Alarm 1 H'00000004 (4): Alarm 2 H'00000005 (5): Alarm 3 H'00000006 (6): Program end output (See note 1.) H'00000007 (7): Control output ON/OFF count alarm (See note 2.) H'00000008 (8): Work bit 1 H'00000009 (9): Work bit 2 H'0000000A (10): Work bit 3 H'0000000B (11): Work bit 4 H'0000000C (12): Work bit 5 H'0000000D (13): Work bit 6 H'0000000E (14): Work bit 7 H'0000000F (15): Work bit 8	Advanced function setting
C3 (83)	0051	Auxiliary Output 2 Assignment	H'00000000 to H'0000000F (0 to 15) * Same as for the Auxiliary Output 1 Assignment parameter.	
C3 (83)	0052	Character Select	H'00000000 (0): OFF H'00000001 (1): ON	
C3 (83)	0053	Program Pattern	H'00000000 (0): OFF H'00000001 (1): STOP H'00000002 (2): CONT	Initial setting
C3 (83)	0054	Soak Time Unit	H'00000000 (0): Minutes H'00000001 (1): Hours	Advanced function setting
C3 (83)	0055	Alarm SP Selection	H'00000000 (0): Set point during SP ramp H'00000001 (1): Set point	
C3 (83)	0056	Auxiliary Output 3 Assignment	H'00000000 to H'0000000F (0 to 15) * Same as for the Auxiliary Output 1 Assignment parameter.	
C3 (83)	005B	Manual MV Limit Enable	H'00000000 (0): OFF H'00000001 (1): ON	
C3 (83)	005D	AT Calculated Gain	H'00000001 to H'00000064 (0.1 to 10.0)	
C3 (83)	005E	AT Hysteresis	H'00000001 to H'0000270F (0.1 to 999.9: Controllers with TC/Pt universal input) (0.01 to 9.99: Controllers with analog input)	
C3 (83)	005F	Limit Cycle MV Amplitude	H'00000032 to H'000001F4 (5.0 to 50.0)	
C3 (83)	0067	PV Rate of Change Calculation Period	H'00000001 to H'000003E7 (1 to 999)	
C3 (83)	0068	Automatic Cooling Coefficient Adjustment	H'00000000 (0): OFF H'00000001 (1): ON	
C3 (83)	0069	Heater Overcurrent Use	H'00000000 (0): OFF H'00000001 (1): ON	
C3 (83)	006A	Heater Overcurrent Latch	H'00000000 (0): OFF H'00000001 (1): ON	
C3 (83)	006B	Heater Overcurrent Hysteresis	H'00000001 to H'000001F4 (0.1 to 50.0)	

Note 1: P.END (program end output) can be set even when the program pattern is set to OFF, but the function will be disabled.

Note 2: The output turns ON when the status of either the Control Output 1 ON/OFF Count Alarm or the Control Output 2 ON/OFF Count Alarm turns ON.

Variable type	Address	Parameter name	Setting (monitor) value	Level
C3 (83)	006C	Extraction of Square Root Enable	H'00000000 (0): OFF H'00000001 (1): ON	Initial setting
C3 (83)	006D	PF Setting	H'00000000 (0): Not assigned. H'00000001 (1): Run H'00000002 (2): Stop H'00000003 (3): RUN/STOP H'00000004 (4): 100% AT execute H'00000005 (5): 40% AT execute H'00000006 (6): Alarm latch cancel H'00000007 (7): Auto/manual switch H'00000008 (8): Monitor/setting item	Advanced function setting
C3 (83)	006E	Monitor/Setting Item 1	H'00000000 (0): Disabled H'00000001 (1): PV/SP/Multi-SP H'00000002 (2): PV/SP/MV H'00000003 (3): PV/SP/soak time remain H'00000004 (4): Proportional band (P) H'00000005 (5): Integral time (I) H'00000006 (6): Derivative time (D) H'00000007 (7): Alarm value 1 H'00000008 (8): Alarm value upper limit 1 H'00000009 (9): Alarm value lower limit 1 H'0000000A (10): Alarm value 2 H'0000000B (11): Alarm value upper limit 2 H'0000000C (12): Alarm value lower limit 2 H'0000000D (13): Alarm value 3 H'0000000E (14): Alarm value upper limit 3 H'0000000F (15): Alarm value lower limit 3	
C3 (83)	006F	Monitor/Setting Item 2	H'00000000 to H'0000000F (0 to 15) * Same as for Monitor/Setting Item 1.	
C3 (83)	0070	Monitor/Setting Item 3	H'00000000 to H'0000000F (0 to 15) * Same as for Monitor/Setting Item 1.	
C3 (83)	0071	Monitor/Setting Item 4	H'00000000 to H'0000000F (0 to 15) * Same as for Monitor/Setting Item 1.	
C3 (83)	0072	Monitor/Setting Item 5	H'00000000 to H'0000000F (0 to 15) * Same as for Monitor/Setting Item 1.	
C3 (83)	0073	PV/SP Display Screen Selection	H'00000000 (0): PV/SP H'00000001 (1): PV/SP/Multi-SP H'00000002 (2): PV/SP/MV H'00000003 (3): PV/SP/Multi-SP H'00000004 (4): PV/SP/MV H'00000005 (5): PV/SP/Multi-SP H'00000006 (6): PV/SP/Soak Time Remain H'00000007 (7): PV/SP/MV H'00000008 (8): PV/SP/Soak Time Remain H'00000009 (9): PV/SP/Soak Time Remain	
C3 (83)	0074	MV Display Selection	H'00000000 (0): MV (heating) H'00000001 (1): MV (cooling)	
C3 (83)	0075	PV Decimal Point Display	H'00000000 (0): OFF H'00000001 (1): ON	

SECTION 3 Communications Data for CompoWay/F and SYSWAY

Variable type	Address	Parameter name	Setting (monitor) value	Level
C3 (83)	0076	PV Status Display Function	H'00000000 (0): OFF H'00000001 (1): Manual H'00000002 (2): Stop H'00000003 (3): Alarm 1 H'00000004 (4): Alarm 2 H'00000005 (5): Alarm 3 H'00000006 (6): Alarm 1 to 3 OR status H'00000007 (7): Heater alarm	Advanced function setting
C3 (83)	0077	SV Status Display Function	H'00000000 to H'00000006 (0 to 7) * Same as for PV Status Display Function	
C3 (83)	0078	Control Output 1 ON/OFF Count Alarm Set Value	H'00000000 to H'0000270F (0 to 9999)	
C3 (83)	0079	Control Output 2 ON/OFF Count Alarm Set Value	H'00000000 to H'0000270F (0 to 9999)	
C3 (83)	0083	Display Refresh Period	H'00000000 (0): OFF H'00000001 (1): 0.25 H'00000002 (2): 0.5 H'00000003 (3): 1.0	





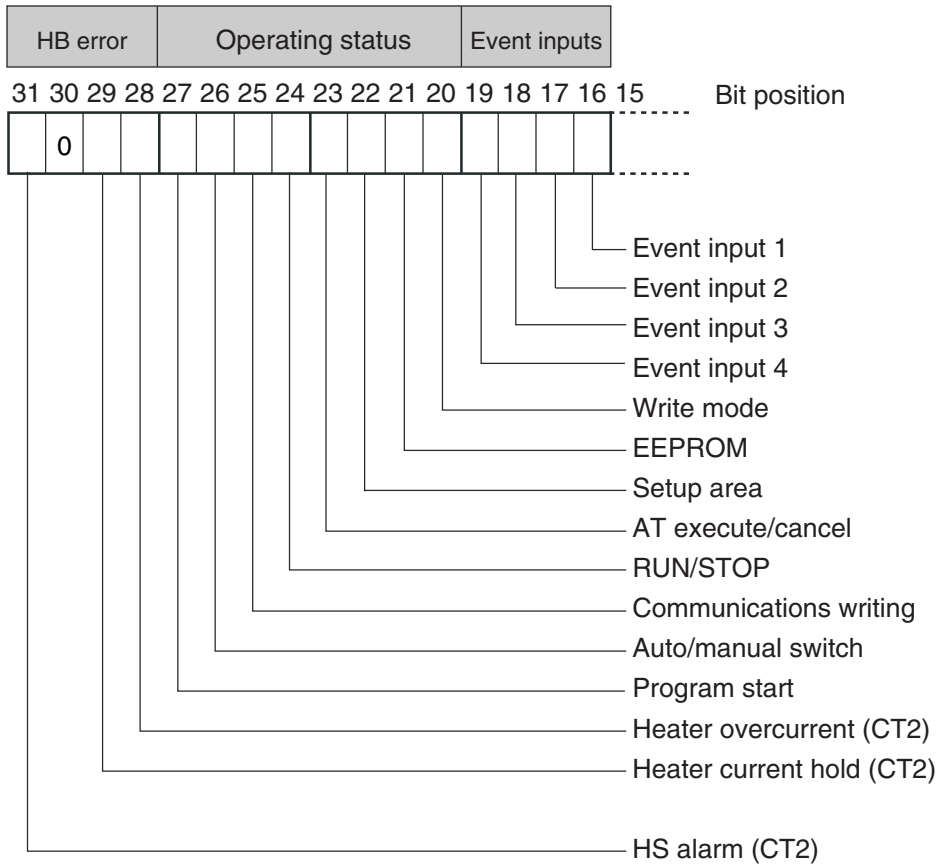

Com Data for CompoWay/F

## ■ Status 2 Structure

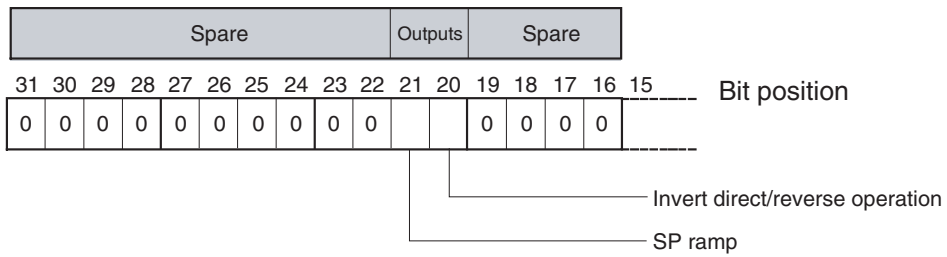
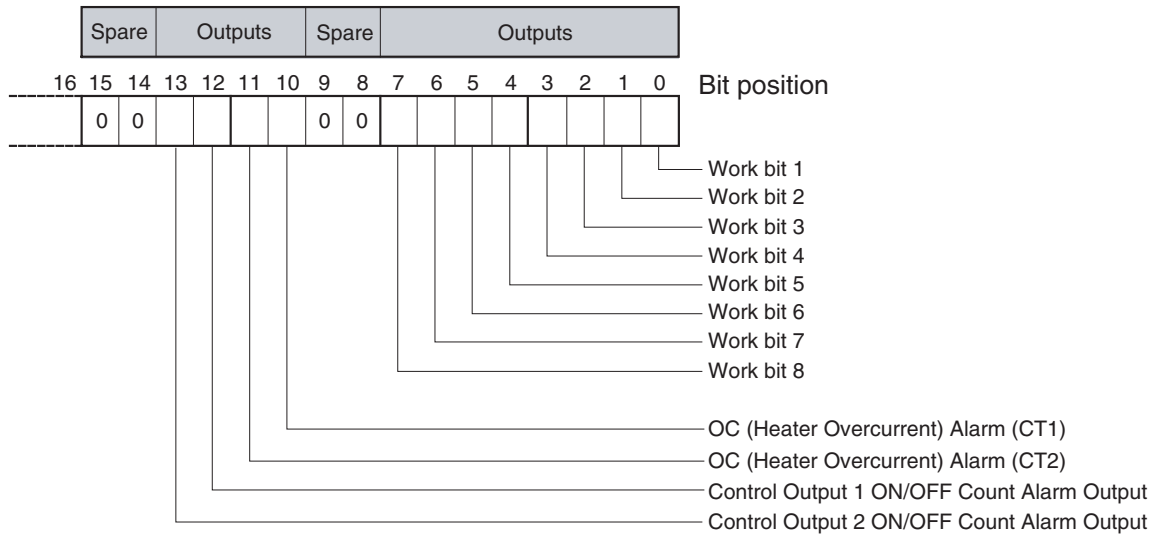

## ■ Status Details

Bit position		Status	Bit Description	
			0	1
Sta- tus (lower word)	0	Heater overcurrent (CT1)	Not generated	Generated
	1	Heater current hold (CT1) (See note 1.)	Update	Hold
	2	A/D converter error	Not generated	Generated
	3	HS alarm (CT1)	OFF	ON
	4	Spare	OFF	---
	5	Display range exceeded	Not generated	Generated
	6	Input error	Not generated	Generated
	7	Spare	OFF	---
	8	Control output (heating)	OFF	ON
	9	Control output (cooling)	OFF	ON
	10	HB (heater burnout) alarm (CT1)	OFF	ON
	11	HB (heater burnout) alarm (CT2)	OFF	ON
	12	Alarm 1	OFF	ON
	13	Alarm 2	OFF	ON
	14	Alarm 3	OFF	ON
15	Program end output	OFF	ON	
Sta- tus (upper word)	16	Event input 1	OFF	ON
	17	Event input 2	OFF	ON
	18	Event input 3	OFF	ON
	19	Event input 4	OFF	ON
	20	Write mode	Backup mode	RAM write mode
	21	EEPROM	RAM = EEPROM	RAM ≠ EEPROM
	22	Setup area	Setup area 0	Setup area 1
	23	AT execute/cancel	AT canceled	AT execution in progress
	24	RUN/STOP	Run	Stop
	25	Communications writing	OFF (disabled)	ON (enabled)
	26	Auto/manual switch	Automatic mode	Manual mode
	27	Program start	Reset	Start
	28	Heater overcurrent (CT2)	Not generated	Generated
	29	Heater current hold (CT2) (See note 1.)	Update	Hold
	30	Spare	OFF	---
	31	HS alarm (CT2)	OFF	ON

Note 1: When the control output ON time is less than 100 ms, the bit is set to “1” and the heater current is held at the last current value.

Note 2: “Spare” bits are always OFF.

Note 3: When read in setup area 1, the status of the bits will be as follows:

- Overcurrent: Last value held
- A/D converter error: Last value held
- Input error: Last value held
- HB and HS outputs: Cleared
- Program end output: Cleared
- Current hold: Last value held
- Display range exceeded: Last value held
- Heating and cooling outputs: Cleared
- Alarm outputs: Cleared

## ■ Status 2 Details

Bit position		Status	Bit Description	
			0	1
Sta- tus (lower word)	0	Work bit 1	OFF	ON
	1	Work bit 2	OFF	ON
	2	Work bit 3	OFF	ON
	3	Work bit 4	OFF	ON
	4	Work bit 5	OFF	ON
	5	Work bit 6	OFF	ON
	6	Work bit 7	OFF	ON
	7	Work bit 8	OFF	ON
	8	Spare	OFF	---
	9	Spare	OFF	---
	10	OC (Heater Overcurrent) Alarm (CT1)	OFF	ON
	11	OC (Heater Overcurrent) Alarm (CT2)	OFF	ON
	12	Control Output 1 ON/OFF Count Alarm Output	OFF	ON
	13	Control Output 2 ON/OFF Count Alarm Output	OFF	ON
	14	Spare	OFF	---
15	Spare	OFF	---	
Sta- tus (upper word)	16	Spare	OFF	---
	17	Spare	OFF	---
	18	Spare	OFF	---
	19	Spare	OFF	---
	20	Invert direct/reverse operation	Not invert	Invert
	21	SP ramp	OFF	During SP ramp
	22	Spare	OFF	---
	23	Spare	OFF	---
	24	Spare	OFF	---
	25	Spare	OFF	---
	26	Spare	OFF	---
	27	Spare	OFF	---
	28	Spare	OFF	---
	29	Spare	OFF	---
	30	Spare	OFF	---
	31	Spare	OFF	---

Note 1: "Spare" bits are always OFF.

Note 2: When read in setup area 1, the status of the bits will be as follows:

- Overcurrent Output: Cleared
- Control Output 1 ON/OFF Count Alarm: Cleared
- Control Output 2 ON/OFF Count Alarm: Cleared
- Work bits 1 to 8: Last value held
- SP ramp: Last value held



# SECTION 4

## SYSWAY (E5□J and E5□X Format) Communications Procedures

These communications procedures are supported to provide compatibility with the E5□J and E5□X Digital Temperature Controllers. When using a new system, we recommend using CompoWay/F communications.

4.1	Data Format.....	4-2
	Command Frame Format .....	4-2
	FCS Calculation Example .....	4-2
	Response Frame .....	4-3
	Communications Data .....	4-3
	SYSWAY Command Lists .....	4-4
4.2	Command Descriptions .....	4-5
	Read Process Value.....	4-5
	Write Set Values.....	4-6
	Read Set Values and MV Monitor .....	4-7
	Select Communications Writing.....	4-9

## 4.1 Data Format

### Command Frame Format

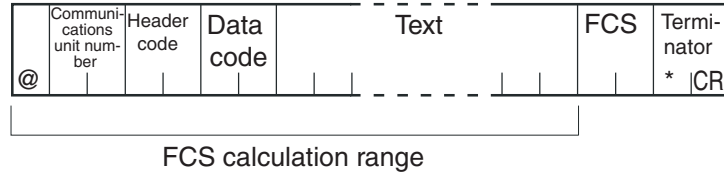

@	The @ character (ASCII H'40) indicates the start of block format.
Communications unit number	A number within the range 0 to 99 can be set in BCD. No response will be returned to a node with a number outside of this range.
Header code	This is a 2-character alphabetic code that indicates the command type.
Data code	Set "02" only when reading and writing alarm value 2. Otherwise, set "01."
Text	This area contains read values, write values, or status data. The data depends on the command.
FCS	This is the Frame Check Sequence. The FCS (Frame Check Sequence) is calculated by taking the exclusive OR of all characters from the @ character to the last text character and converting the result to ASCII characters.
Terminator	Indicates the end of the block format. The terminator is composed of "*" and CR (Carriage Return = H'0D).

### FCS Calculation Example

The FCS (Frame Check Sequence) is calculated by taking the exclusive OR of all characters from the @ character to the last text character and converting that 8-bit result into two ASCII characters.

Start character	Communication unit number	Header code	Data code	FCS	
@ (40H)	0 (30H)	0 (30H)	R (52H) X (58H)	0 (30H) 1 (31H)	4 (34H) B (42H)

$$\text{FCS} = 40\text{H} \oplus 30\text{H} \oplus 30\text{H} \oplus 52\text{H} \oplus 58\text{H} \oplus 30\text{H} \oplus 31\text{H} = 4\text{BH}$$

The calculation result (4B hex) is converted to ASCII and written to the FCS bytes.

4 → 34H

B → 42H

The ⊕ symbols indicate XOR (exclusive OR) operations.



## ■ Response Frame



End code	Name	Description	Priority
10	Parity error	The sum total of bits whose received data is "1" does not match the set value of "communications parity."	1
11	Framing error	Stop bit is "0."	2
12	Overrun error	An attempt was made to transfer new data when the reception data buffer was already full.	3
13	FCS error	The calculated FCS value is different from the received FCS value.	4
IC (See note.)	Undefined error	The header code of the command cannot be interpreted.	5
14	Format error	The command length is incorrect.	6
0D	Non-executable command	<ul style="list-style-type: none"> <li>The set value was written when the Communications Writing parameter was set to "OFF" (disabled).</li> <li>The set value was written during AT execution.</li> </ul>	7
15	Undefined data value	<ul style="list-style-type: none"> <li>The write data is either outside the setting range or not a numerical value.</li> <li>The data code is either outside the setting range or not a numerical value.</li> </ul>	8
00	Normal completion	The command ended normally without error.	---

Note: The response format is unusual when an "Undefined error" has occurred due to an invalid command header code. The error code will be contained in the response's header code rather than the end code. See the following diagram for details.

Response Format when an "Undefined Error" Occurred

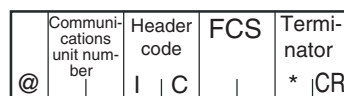

## ■ Communications Data

Communica- tions Format	Setting (monitor) value	Negative values	Decimal Point
SYSWAY	Four digits (decimal)	If the leftmost digit is "-1," it is set to "A." Example: -1999 → A999 If the leftmost digit is "-", it is set to "F." Example: -10 → F010	The decimal point is removed. Example: 105.0 → 1050

### ■ SYSWAY Command Lists

Category	Header code	Data code	Command	R/W	Data length	Remarks
Selecting Communications Writing	MB	01	Select communications writing	Write	4B	
Write mode selection (See note 1.)	ME	01	Select backup mode	Write	None	
	MA	01	Select RAM write mode			
Save operation/adjustment set value	MW	01	Save operation/adjustment set value			
Writing set values	WS	01	Write set point	Write	4B	
	W%	01	Write alarm value 1			
	W%	02	Write alarm value 2			
	WB	01	Write proportional band			
	WN	01	Write integral time			
	WV	01	Write derivative time			
	WI	01	Write temperature input shift values			
	WW	01	Write heater burnout detection			
Read set value and manipulated variable monitor	RS	01	Read set point	Read	4B	
	R%	01	Write alarm value 1			
	R%	02	Write alarm value 2			
	RB	01	Read proportional band			
	RN	01	Write integral time			
	RV	01	Write derivative time			
	RI	01	Write temperature input shift values			
	RW	01	Write heater burnout detection			
	RO	01	Read MV monitor			
Read SP upper and lower limit values	RL	01	Read SP upper and lower limit values	Read	8B	Read both upper/lower limit values at once
Read process value	RX	01	Read process value	Read	8B	See note 2.
Read the heater current monitor	RZ	01	Heater current value monitor	Read	8B	See note 3.
Read the initial status	RU	01	Read the initial status	Read	5B	See note 4.

- No commands will be accepted and no responses will be returned when a memory error (RAM error) has occurred or during initialization (until the process value is recognized after power is turned ON).
- When a write operation is performed while there is a memory error (EEPROM error), data will not be written and the command will end with “normal completion.” Read operations will be executed normally.

Note 1: The number of EEPROM (non-volatile memory) write operations is limited. Therefore, use RAM write mode when frequently overwriting data.

Note 2: The process value read range is the same as the input's display range.

Note 3: Status (last 4 bytes)

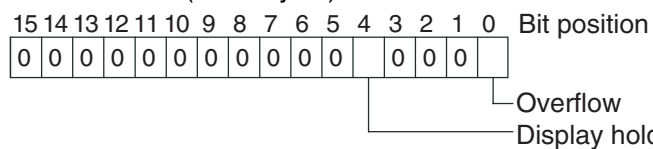

Note 4: Status (first 2 bytes)

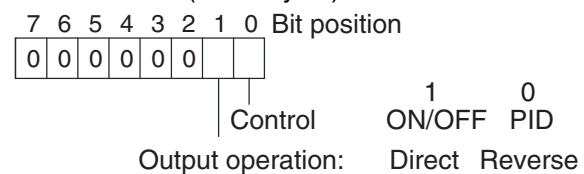

- Overflow: Set 1 when the heater current value is greater than 55.0 A.
- Display hold: Set 1 when the control output ON time is less than 100 ms. The previous heater current value is held.

## 4.2 Command Descriptions

### ■ Read Process Value

This command reads the process value and status.

Command

@	Communi- cations unit num- ber	Header code R   X	Data code 0   1	FCS	Termi- nator *   CR
---	---	-------------------------	-----------------------	-----	---------------------------

Response

@	Communi- cations unit num- ber	Header code R   X	End code	PV	Status	FCS	Termi- nator *   CR
---	---	-------------------------	-------------	----	--------	-----	---------------------------

(1) PV

See *SECTION 3 Communications Data for CompoWay/F and SYSWAY*.

(2) Status

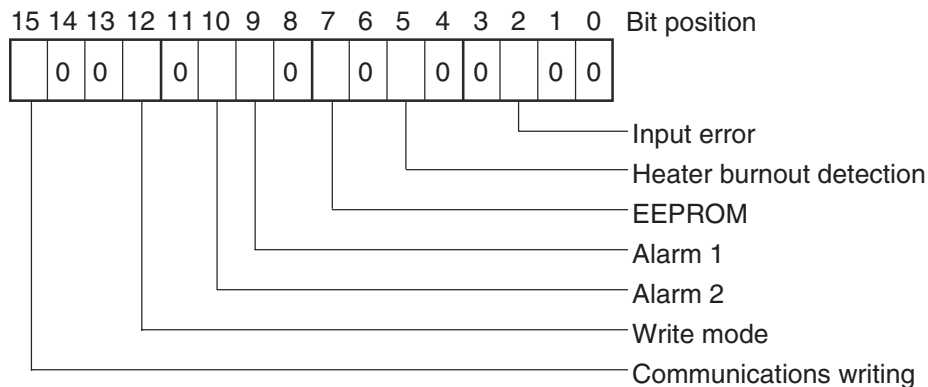

Item	Description	
	0	1
Input error	Not generated	Generated
Heater burnout detection (See note 1.)	OFF or does not function	ON
EEPROM	RAM = EEPROM	RAM ≠ EEPROM
Alarm 1	OFF or does not function	ON
Alarm 2	OFF or does not function	ON
Write mode	Backup mode	RAM write mode
Communications writing	OFF (disabled) or does not function	ON (enabled)

Note: When reading from setup area 1, the status of the bits will be as follows:

- Input error: Last value held
- Heater burnout detection: Cleared

- Alarms 1 and 2: Cleared

Note 1. Heater burnout is the status corresponding to heater burnout 1 (CT1).

(3) End Code

When the end code is “00,” this indicates normal completion of the command. Otherwise, the command could not be processed. For details on end codes, see *Response Frame* on page 4-3.

(4) Precautions

- Even though alarms 1 and 2 are not displayed on the Controller display, they function normally in communications.

## ■ Write Set Values

This command writes the set point, alarm values 1 and 2, proportional band, integral time, derivative time, temperature input shift values, and heater burnout detection.

Command

@	Communi- cations unit num- ber	Header code	Data code	Write value	FCS	Termi- nator *  CR
---	---	----------------	--------------	----------------	-----	--------------------------

Response

@	Communi- cations unit num- ber	Header code	End code	FCS	Termi- nator *  CR
---	---	----------------	-------------	-----	--------------------------

(1) Header Code

Header code	Command
WS	Write set point
W%	Write alarm values 1 and 2
WB	Write proportional band
WN	Write integral time
WV	Write derivative time
WI	Write temperature input shift values
WW	Write heater burnout detection

(2) Data Code

Set the data code to “02” only when writing alarm value 2. In all other cases, set to “01.”

(3) Write Value

For details on the write value (set value) range, see *SECTION 3 Communications Data for CompoWay/F and SYSWAY*.

## (4) Precautions

## ● Alarm Values 1 and 2

When the alarm 1 type is set to “upper and lower-limit alarm,” “upper and lower-limit range alarm,” or “upper and lower-limit alarm with standby sequence,” the alarm’s upper and lower limits are set independently. The “alarm value 1” setting is disabled and the “alarm value upper limit 1” and “alarm value lower limit 1” settings are used as the alarm set values.

For this reason, when an “upper and lower-limit alarm” is set, write values are written by communications to “alarm value upper limit 1” and “alarm value lower limit 1” and not to “alarm value 1.” The same applies to “alarm value 2.”

## ● Temperature Input Shift Value

When the 2-point shift method is used, the Temperature Input Shift is disabled and the Upper Limit Temperature Input Shift Value and Lower Limit Temperature Input Shift Value parameters are enabled as the temperature input shift set values. For this reason, write values are written to the Upper Limit Temperature Input Shift Value and Lower Limit Temperature Input Shift Value parameters and not to the Temperature Input Shift parameter.

The 2-point shift method will be used in the following cases:

- The Input Type parameter is set to infrared temperature sensor.
- The Input Type parameter is not set to infrared temperature sensor, but the Input Shift Type parameter is set to 2-point shift.

## ● Alarms

- Even when alarms 1 and 2 are not displayed on the Controller's display, they function normally in communications.
- Only alarms 1 and 2 are supported.
- Alarm 3 cannot be used.

## ● Heater Burnout Detection

Written to “heater burnout detection 1.” (The value is not written to “heater burnout 2 detection.”)

## ■ Read Set Values and MV Monitor

This command reads the set point, alarm values 1 and 2, proportional band, integral time, derivative time, temperature input shift values, heater burnout detection, and MV monitor.

## Command

	Communi- cations unit num- ber	Header code	Data code	FCS	Termi- nator
@					*  CR

## Response

@	Communi- cations unit num- ber	Header code	End code	Read value	FCS	Termi- nator *   CR
---	---	----------------	-------------	------------	-----	---------------------------

## (1) Header Code

Header code	Command
RS	Read set point
R%	Read alarm values 1 and 2
RB	Read proportional band
RN	Read integral time
RV	Read derivative time
RI	Read temperature input shift val- ues
RW	Read heater burnout detection
RO	Read MV monitor

## (2) Data Code

Set the data code to “02” only when writing alarm value 2. In all other cases, set to “01.”

## (3) Read Value

For details on the read value ranges, see *SECTION 3 Communications Data for CompoWay/F and SYSWAY*.

## (4) Precautions

## ● Alarm Values 1 and 2

When the alarm 1 type is set to “upper and lower-limit alarm,” “upper and lower-limit range alarm,” or “upper and lower-limit alarm with standby sequence,” the alarm’s upper and lower limits are set independently. The “alarm value 1” setting is disabled and the “alarm value upper limit 1” and “alarm value lower limit 1” settings are used as the alarm set values.

For this reason, when “upper/lower-limit alarm” is set, the value of “alarm value upper limit 1” and not “alarm value 1” is the value read by communications. The same applies to “alarm value 2.”

## ● Temperature Input Shift Value

When the 2-point shift method is used, the Temperature Input Shift parameter is disabled and the Upper Limit Temperature Input Shift Value and Lower Limit Temperature Input Shift Value parameters are enabled as the temperature input shift set values. For this reason, when 2-point shift method is being used, the Upper Limit Temperature Input Shift Value parameter is read and not the Temperature Input Shift parameter.

The 2-point shift method will be used in the following cases:

- The Input Type parameter is set to infrared temperature sensor.
- The Input Type parameter is not set to infrared temperature sensor, but the Input Shift Type parameter is set to 2-point shift.

- Alarm

- Even when alarms 1 and 2 are not displayed on the Controller's display, they function normally in communications.
- Only alarms 1 and 2 are supported.
- Alarm 3 cannot be used.

- Heater Burnout Detection

Reads the Heater Burnout Detection 1 parameter. (The Heater Burnout Detection 2 parameter value is not read.)

## ■ Select Communications Writing

The logic of the MB command changes as shown in the table below according to the MB command logic switching setting (advanced function setting level). The MB command (communications writing selection) is equivalent to the E5□J Controller's MB command (remote/local switching).

Text data of MB command	MB command logic switching setting	
	OFF	ON
0000	Communications writing enabled (remote mode selection)	Communications writing disabled (local mode selection)
0001	Communications writing disabled (local mode selection)	Communications writing enabled (remote mode selection)

- The default value of the MB Command Logic Switching Setting is OFF (same logic as E5□J).





# SECTION 5

## Modbus Communications Procedure

Read this section if you are to communicate using the Modbus format.

5.1	Data Format.....	5-2
	Command Frame.....	5-2
	CRC-16 Calculation Example.....	5-3
	Response Frame .....	5-4
	Normal Response Frame .....	5-4
	Error Response Frame.....	5-4
	Error Codes .....	5-5
	No Response.....	5-5
5.2	Function List .....	5-6
5.3	Variable Area .....	5-7
	Addresses .....	5-7
	Number of Elements.....	5-8
	Set Values .....	5-8
5.4	Detailed Description of the Services.....	5-9
	Variable Read, Multiple .....	5-9
	Variable Write, Multiple.....	5-11
	Variable Write, Single/Operation Command.....	5-14
	Echoback Test.....	5-20

## 5.1 Data Format

The data format complies with the Modbus (RTU) communications protocol, so commands from the host and responses from the E5CN/AN/EN/GN are contained in data blocks called frames.

The structure of the command and response frames is described below.

In the following explanations, hexadecimal values are expressed by adding the prefix H' before the number, e.g., H'02. Numbers and alphabetic characters without the H' prefix are ASCII characters.

### ■ Command Frame

When using RTU mode, start with a silent interval of at least 3.5 character times and end with a silent interval of at least 3.5 character times.

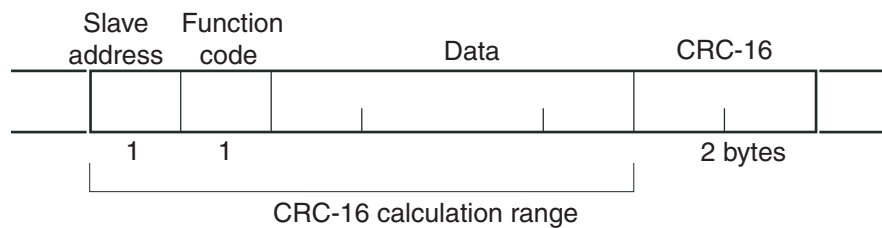

	Silent interval of 3.5 character times minimum.
<b>Slave address</b>	Specify the unit number. The unit number can be set between H'00 to H'63 hexadecimal (0 to 99 decimal). Specify H'00 for a broadcast transmission. No responses will be returned for broadcast transmissions.
<b>Function code</b>	The function code is a 1-byte hexadecimal code that indicates the type of command sent from the host device.
<b>Data</b>	This is the text data associated with the specified function code. Specify the required data, such as the variable address or setting data. (Set in hexadecimal.)
<b>CRC-16</b>	Cyclical Redundancy Check This check code is calculated with the data from the slave address to the end of the data. The check code is 2-byte hexadecimal.
	Silent interval of 3.5 character times minimum.

## ● CRC-16 Calculation Example

Messages are processed one byte at a time in the work memory (a 16-bit register known as the CRC register).

- (1) The CRC register is initialized to H'FFFF.
- (2) An XOR operation is performed on the content of the CRC register and the first byte of the message, and the result is returned to the CRC register.
- (3) The MSB is packed with zeroes and the CRC register is shifted 1 bit to the right.
- (4) If the bit shifted from the LSB is 0, step 3 is repeated (next bit-shift processing).  
If the bit shifted from the LSB is 1, an XOR is performed on the content of the CRC register and H'A001, and the result is returned to the CRC register.
- (5) Steps 3 and 4 are repeated until 8 bits are shifted.
- (6) CRC processing continues to the end of the message, as XOR operations are performed on the content of the CRC register and the next byte of the message, step 3 is repeated, and the result is returned to the CRC register.
- (7) The result of the CRC calculation (value in the CRC register) is appended to the last byte of the message.

### Example of Appending the Calculation Result

When the calculated CRC value is H'1234, the CRC value is appended to the command frame as follows.

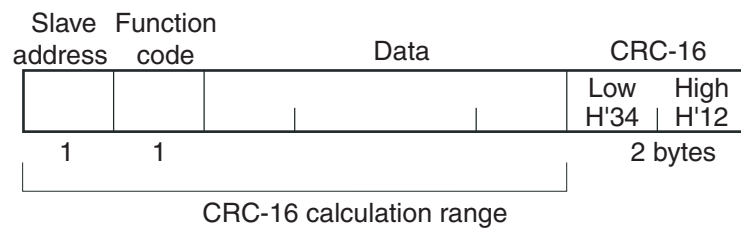

## ■ Response Frame

### ● Normal Response Frame

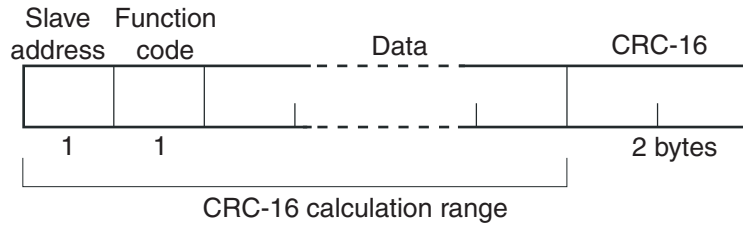

### ● Error Response Frame

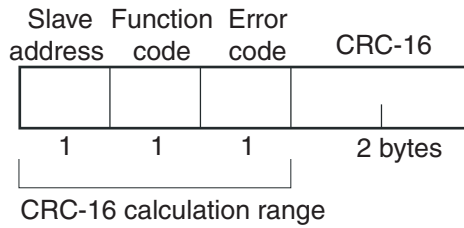

<b>Slave address</b>	The number specified in the command frame is entered as-is. This is the unit number of the Unit returning the response.
<b>Function code</b>	This is the received function code with the hexadecimal value of H'80 added to indicate that the response is an error response. Example: Received function code = H'03 Function code in response frame when an error occurred = H'83
<b>Error code</b>	This code indicates the kind of error that occurred.
<b>CRC-16</b>	Cyclical Redundancy Check This check code is calculated with the data from the slave address to the end of the data. The check code is 2-byte hexadecimal.

## ■ Error Codes

End code	Name	Description	Error detection priority
H'01	Function code error	An unsupported function code was received.	1
H'02	Variable address error	The specified variable area address is out-of-range.	2
H'03	Variable data error	The amount of data does not match the number of elements. The byte count is not 2 times the number of elements. The response length exceeds the size of the communications buffer. The command code or related information in the operation command is wrong or the write data is not in the setting range.	3
H'04	Operation error	The write data contents are not allowed in the present operation mode. <ul style="list-style-type: none"> <li>◆ The Communications Writing parameter is set to "OFF" (disabled).</li> <li>◆ Attempted to write to a parameter in setup area 1 from setup area 0.</li> <li>◆ Attempted to write to a protect parameter from other than the protect level.</li> <li>◆ AT execution in progress</li> <li>◆ The command cannot be processed.</li> </ul>	4

## ● No Response

In the following cases, the received command will not be processed and a response will not be returned.

Consequently, a timeout error will occur at the host device.

- The slave address in the received command does not match the communications unit number.
- A parity error, framing error, or overrun error occurred due to a problem such as a transfer error.
- A CRC-16 code error occurred in the received command frame.
- There was a time interval of more than 3.5 character times between data packets that make up the command frame.

Furthermore, the specified function's processing will be performed but no response will be returned for broadcast functions (slave address = H'00).

## 5.2 Function List

The following table lists the function codes.

Function Code List

Function code	Name	Process
03 (H'03)	Read variable (multiple)	This function reads from the variable area. It is possible to read two or more consecutive variables.
16 (H'10)	Write variable (multiple)	This function writes to the variable area. It is possible to write two or more consecutive variables. It is also possible to broadcast this function (broadcast transmission).
06 (H'06)	Write variable (Single/operation command)	This function writes to the variable area and writes operation commands. It is also possible to write to a single parameter by specifying the address in 2-byte mode. (This is not supported in 4-byte mode.) It is also possible to broadcast this function (broadcast transmission.)
08 (H'08)	Echoback Test	This function performs an echoback test.



Setup area 0 and setup area 1 do not correspond directly to Modbus addresses, but the following areas have a rough correspondence with one exception.

Setup area	Modbus addresses	
	Area number	Address range
Setup area 0	00 to 0B, 20 to 2B	0000 to 0BFE, 2000 to 2B7F
Setup area 1	0C to 13, 2C to 33	0C00 to 1366, 2C00 to 3333

\* Partial Exception to Modbus Address Correspondence

The Hysteresis (Heating), Hysteresis (Cooling), Control Period (Heating), and Control Period (Cooling) parameters are assigned to consecutive addresses, but the control period parameters are setup area 1 parameters. For this reason, an operation error will occur when writing the control period (heating or cooling) from the setup area 0 side, e.g., from the operation level.

## ● Number of Elements

The number of elements is expressed in 2-byte hexadecimal. The setting range for the number of elements varies according to the command.

For example, when the number of elements is "0010," this specifies eight items of data (H'10) from the address.

- **Four-byte Mode**

One element uses 2 bytes of data, so specify two-element units. Reading and writing in 4-byte units is executed by specifying an even address and specifying the number of elements in multiples of 2.

- **Two-byte Mode**

One element uses 2 bytes of data, so specify one-element units. Reading and writing in 2-byte data units is executed by specifying 1-element units.

## ● Set Values

The values read from the variable area or written to the variable area are expressed in hexadecimal, ignoring the decimal point position. (Negative values are expressed in 2's complement format.)

Example: D'105.0 → H'0000041A

The variables are 4-digit or 8-digit hexadecimal values. Negative values are expressed in 2's complement format. The values are hexadecimal values with no decimal point indication.

For example, if the E5CN/AN/EN/GN's process value is read in 4-byte mode when the process value is 105.0, the read value will be H'0000041A (105.0 → 1050 → H'0000041A).



## 5.4 Detailed Description of the Services

### ■ Variable Read, Multiple

To read from the variable area, set the required data in the command frame, as shown in the following diagram.

Command Frame

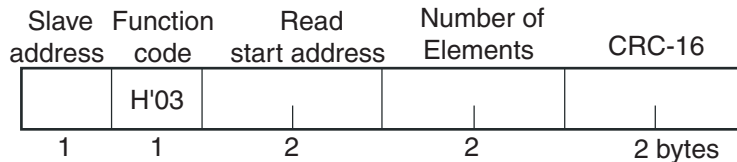

Name	Description
Slave address	Specify the E5CN/AN/EN/GN's unit number. The unit number can be set between H'01 and H'63 hexadecimal (1 to 99 decimal).
Function code	The Read Variable Area function's function code is H'03.
Read start address	Specify the address containing the data to be read. See <i>SECTION 6 Communications Data for Modbus</i> for details on addresses.
Number of elements	<p>4-byte Mode</p> <p>Specify 2 times the number of setting data items as the number of elements to be read. The setting range for the number of elements is H'0002 to H'006A (2 to 106). When H'006A is set, 53 items of setting data can be read. Example: When reading 2 items of setting data, set the number of elements to H'0004.</p>
	<p>2-byte Mode</p> <p>Specify the number of setting data items to be read as the number of elements. The setting range for the number of elements is H'0001 to H'006A (1 to 106). When H'006A is set, 106 items of setting data can be read. Example: When reading two items of setting data, set the number of elements to H'0002.</p>
CRC-16	This check code is calculated with the data from the slave address to the end of the data. For details on the CRC-16 calculation, see <i>CRC-16 Calculation Example</i> in <i>5.1 Data Format</i> on page 5-3.

## Response Frame

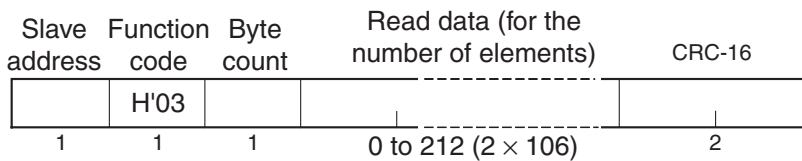

Name	Description
Slave address	The value from the command frame is entered as-is.
Function code	This is the received function code. When the function ended normally, the function code is left as-is. When an error occurred, the hexadecimal value of H'80 is added to the function code to indicate that the response is an error response. Example: Received function code = H'03 Function code in response frame when an error occurred = H'83
Byte count	Contains the number of bytes of read data.
Number of elements	Contains the number of setting data items that were read.
CRC-16	This check code is calculated with the data from the slave address to the end of the data. For details on the CRC-16 calculation, see <i>CRC-16 Calculation Example</i> in 5.1 Data Format on page 5-3.

## Response Code

Function code	Error code	Error name	Cause
H'83	H'02	Variable address error	The read start variable address is incorrect. <ul style="list-style-type: none"> <li>The variable area number is incorrect.</li> </ul>
	H'03	Variable data error	The number of elements exceeds the allowed range.
H'03	---	Normal completion	No errors were found.

## ◆ Reading Undisplayed Parameters

It is possible to read the parameters that are not displayed due to display settings as well as the parameters that are never displayed in the Controller.

## Example Command and Response

The following example shows the command and response when reading the process value (slave address: H'01).

Process Value in 4-byte Mode

- Address: H'0000; Read data: H'000003E8 (100.0 °C)

Command: 01 03 00 00 00 02 C4 0B(CRC-16)

Response: 01 03 04 00 00 03 E8 FA 8D(CRC-16)

## Process Value in 2-byte Mode

- Address: H'2000; Read data: H'03E8 (100.0 °C)

Command: 01 03 20 00 00 01 8FCA (CRC-16)

Response: 01 03 02 03 E8 B8FA (CRC-16)

## Variable Write, Multiple

To write data to the variable area, set the required data in the command frame, as shown in the following diagram.

### Command Frame

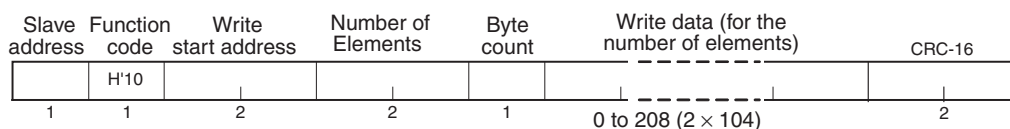

Name	Description
Slave address	Specify the E5CN/AN/EN/GN's unit number. The unit number can be set between H'01 and H'63 hexadecimal (1 to 99 decimal).
Function code	The Write Variable Area function's function code is H'10.
Write start address	Specify the starting address where the setting data will be written. See <i>SECTION 6 Communications Data for Modbus</i> for details on addresses.
Number of elements	<b>4-byte Mode</b> Specify 2 times the number of setting data items as the number of elements to be written. The setting range for the number of elements is H'0002 to H'0068 (2 to 104). When H'0068 is set, 52 items of setting data can be read. Example: When writing 2 items of setting data, set the number of elements to H'0004.
	<b>2-byte Mode</b> Specify the number of setting data items to be written as the number of elements. The setting range for the number of elements is H'0001 to H'0068 (1 to 104). When H'0068 is set, 104 items of setting data can be read. Example: When reading two items of setting data, set the number of elements to H'0002.
Byte count	Specify the number of bytes of write data.
CRC-16	This check code is calculated with the data from the slave address to the end of the data. For details on the CRC-16 calculation, see <i>CRC-16 Calculation Example</i> in <i>5.1 Data Format</i> on page 5-3.

## Response Frame

Slave address	Function code	Write start address	Number of Elements	CRC-16
	H'10			
1	1	2	2	2 bytes

Name	Description
Slave address	The value from the command frame is entered as-is.
Function code	This is the received function code. When the function ended normally, the function code is left as-is. When an error occurred, the hexadecimal value of H'80 is added to the function code to indicate that the response is an error response. Example: Received function code = H'10 Function code in response frame when an error occurred = H'90
Write start address	This is the received write start address.
Number of elements	This is the received number of elements.
CRC-16	This check code is calculated with the data from the slave address to the end of the data. For details on the CRC-16 calculation, see <i>CRC-16 Calculation Example</i> in 5.1 Data Format on page 5-3.

## Response Code

Function code	Error code	Error name	Cause
H'90	H'02	Variable address error	The write start variable address is incorrect. <ul style="list-style-type: none"> <li>The variable area number is incorrect.</li> </ul>
	H'03	Variable data error	<ul style="list-style-type: none"> <li>The amount of data does not match the number of elements.</li> <li>The byte count is not 2 times the number of elements.</li> <li>The write data is out of the setting range.</li> </ul>
	H'04	Operation error	The Controller cannot write the data in its present operating status. The write data contents are not allowed in the present operation mode. <ul style="list-style-type: none"> <li>The Communications Writing parameter is set to "OFF" (disabled).</li> <li>Attempted to write to a parameter in setup area 1 from setup area 0.</li> <li>Attempted to write to a protect parameter from other than the protect level.</li> <li>AT execution in progress</li> </ul>
H'10	---	Normal completion	No errors were found.

◆ Writing Undisplayed Parameters

It is possible to write the parameters that are not displayed due to display settings as well as the parameters that are never displayed in the Controller.

Example Command and Response

The following example shows the command/response when writing the Alarm Value Upper Limit 1 and Alarm Value Lower Limit 1 parameters. (In this case, the slave address is H'01.)

**Four-byte Mode**

Alarm Value Upper Limit 1

- Address: H'010A; Write data: H'000003E8 (when 1000)

Alarm Value Lower Limit 1

- Address: H'010C; Write data: H'FFFFFFC18 (when -1000)

Command: 01 10 01 0A 00 04 08 00 00 03 E8 FF FF FC 18 8D E9(CRC-16)

Response: 01 10 01 0A 00 04 E0 34(CRC-16)

**Two-byte Mode**

Alarm Value Upper Limit 1

- Address: H'2105; Write data: H'03E8 (when 1000)

Alarm Value Lower Limit 1

- Address: H'2106; Write data: H' FC18 (when -1000)

Command: 01 10 21 05 00 02 04 03 E8 FC 18 66BB (CRC-16)

Response: 01 10 21 05 00 02 5BF5 (CRC-16)

## ■ Variable Write, Single/Operation Command

This function performs operations such as writing to the variable area (single) and operation commands (communications writing, RUN/STOP, multi-SP, AT execute/cancel, write mode, save RAM data, software reset, move to setup area 1, move to protect level, auto/manual switch, initialize settings, alarm latch cancel, invert direct/reverse operation, and program start.)

Writing is enabled in only the 2-byte mode.

Command Frame

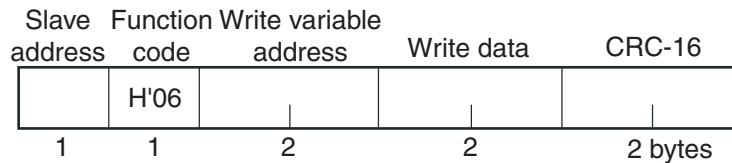

Response Frame

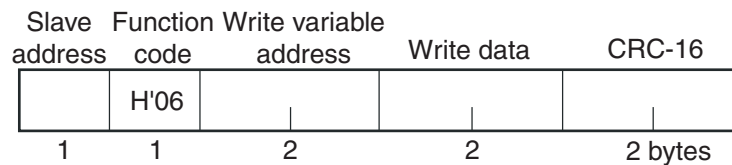

(1) Write variable address

Specify the address of the setting data that is to be written. For details on addresses, refer to *Section 6 Communications Data for Modbus*.

For an operation command, specify 0000 or FFFF.

(2) Command Code and Related Information

Command code	Command content	Related information
00	Communications writing	00: OFF (disabled) 01: ON (enabled)
01	RUN/STOP	00: Run 01: Stop
02	Multi-SP	00: Set point 0 01: Set point 1 02: Set point 2 03: Set point 3
03	AT execute/cancel	00: AT cancel 01: 100% AT execute 02: 40% AT execute
04	Write mode	00: Backup mode 01: RAM write mode
05	Save RAM data	00
06	Software reset	00
07	Move to setup area 1	00
08	Move to protect level	00
09	Auto/manual switch	00: Automatic mode 01: Manual mode

Command code	Command content	Related information
0B	Parameter initialization	00: Initialize to defaults
0C	Alarm latch cancel	00: Alarm 1 latch cancel 01: Alarm 2 latch cancel 02: Alarm 3 latch cancel 03: HB alarm latch cancel 04: HS alarm latch cancel 05: OC alarm latch cancel 0F: All alarm latch cancel
0E	Invert direct/reverse operation	00: Not invert 01: Invert
11	Program start	00: Reset 01: Start

## (3) Response Code

## Normal Completion

Function code	Error code	Name	Description
H'06	---	Normal completion	No errors were found.

## Error Occurred

Function code	Error code	Name	Description
H'86	H'02	Variable address error	The write variable address is incorrect. The variable area number (2-byte data) is wrong, or the address is not 0000 or FFFF.
	H'03	Variable data error	The write data is incorrect. <ul style="list-style-type: none"> <li>The write data is out of the setting range.</li> <li>Command code or related information are incorrect.</li> </ul>
	H'04	Operation error	The Controller cannot write the data in its present operating status. <ul style="list-style-type: none"> <li>The Communications Writing parameter is set to "OFF" (disabled). The command is received regardless of the Communications Writing parameter setting (ON/OFF).</li> <li>Writing was attempted from setup area 0 to setup area 1.</li> <li>Writing was attempted to a protected parameter from outside the protect level.</li> <li>AT execution was in progress.</li> <li>Processing could not be performed. For details, see (5) <i>Operation Commands and Precautions</i> on the next page.</li> </ul>

Note: For details on variable writing, refer to *Variable Write, Multiple* on page 5-11. For details on AT, refer to the E5CN/E5AN/E5EN/E5GN Digital Temperature Controllers User's Manual Basic Type (Cat. No. H156).

#### (4) Example Command and Response

The following example shows the command/response for a Stop command. (In this case, the slave address is H'01.)

Stop command (command code: 01; related information: 01)

•Address: H'0000 (fixed)

Write data: H'0101 (Run/Stop, Stop command)

Command: 

01	06	00 00	01 01	49 9A(CRC-16)
----	----	-------	-------	---------------

Response: 

01	06	00 00	01 01	49 9A(CRC-16)
----	----	-------	-------	---------------

#### (5) Operation Commands and Precautions

##### ● Communications Writing

Set the Communications Writing parameter to “ON” (enabled) or “OFF” (disabled) with the related information setting.

The setting can be accepted in both setup area 0 and setup area 1. An operation error will occur, however, if communications writing enable/disable is set for an event input.

##### ● RUN/STOP

Set control to “run” or “stop” with the related information setting. The setting can be accepted in both setup area 0 and setup area 1. An operation error will occur, however, if RUN/STOP is set for an event input.

##### ● Multi-SP

Set four set points beforehand in the adjustment level so that you can switch to a desired set point. The setting can be accepted in both setup area 0 and setup area 1. An operation error will occur in the following situations.

- When AT is being executed.
- When the Multi-SP Uses parameter is set to OFF.
- When the Multi-SP Uses parameter is set to ON but multi-SP is set for an event input (Number of Multi-SP Uses > 0).

##### ● AT Execute/Cancel

Set AT (auto-tuning) to “execute” or “cancel” with the related information setting. This command can be accepted in setup area 0 only. An “operation error” will be generated in the following instances:

- When the RUN/STOP parameter is set to “stop”
- When the command is executed in “setup area 1”
- When ON/OFF control is being used



- When 40% AT is specified during 100% AT execution.
- When 100% AT is specified during 40% AT execution.

In addition, a parameter error will occur if 40% AT execution is specified during heating and cooling control.

**Note:** If the same type of AT execution is specified during AT execution (e.g., if 100% AT execution is specified during 100% AT execution), the AT will not be restarted and the operation will end in normal completion with no processing.

#### ● Write Mode

Set either “backup mode” or “RAM write mode” with the related information setting. The setting can be accepted in both setup area 0 and setup area 1.

The number of EEPROM (non-volatile memory) write operations is limited. Therefore, use RAM write mode when frequently overwriting data.

Write mode	Description
Backup mode	The data is written to EEPROM when the parameters in the operation/adjustment levels (excluding read-only parameters) are written by communications.
RAM write mode	The data is not written to EEPROM when the parameters in the operation/adjustment levels (excluding read-only parameters) are written by communications. Parameters can be changed by operating the keys on the front panel of the controller.

- When the mode is switched from RAM write mode to backup mode, the parameters in the operation/adjustment levels (excluding read-only parameters) are written to EEPROM.
- The RAM write mode is enabled only when the Communications Writing parameter is set to “ON” (enabled).

Consequently, when the Communications Writing parameter setting is changed to “OFF” (disabled), the parameters in the operation/adjustment levels (excluding read-only parameters) are written to EEPROM even if the RAM write mode is set to “disabled.”

#### ● RAM Data

This command writes the parameters in the operation/adjustment levels (excluding read-only parameters) to EEPROM. The setting can be accepted in both setup area 0 and setup area 1.

#### ● Software Reset

Restarts processing from the point when power is turned ON. The setting can be accepted in both setup area 0 and setup area 1.

● Move to Setup Area 1

This command moves to “setup area 1” and can be accepted at both setup areas 0 and 1. If the “initial setting/communications protect” is set to “2,” an “operation error” will be generated, and the move to setup area 1 will be prohibited.

When this move is carried out from setup area 0, the display indicates the “input type” in the “initial setting level.” When this operation command is executed in setup area 1, the display will not change.

● Move to Protect Level

This command moves to the “protect level” and can be accepted only in setup area 0. When this command is issued in setup area 1, an “operation error” will be generated, and the move to the protect level will be prohibited.

◆ Moving to Protect Level in Manual Mode

When this operation command is issued in manual mode, an “operation error” will be generated, and the move to the protect level will be prohibited.

● Auto/Manual Switch

This operation command switches the mode to manual mode or automatic mode, based on the related information setting. This command can be accepted in setup area 0 only. An “operation error” will be generated in the following instances:

- When the command is executed in “Setup Area 1”
- When auto/manual switching is disabled (not displayed)

When the Controller is switched to manual mode, the “manual manipulated variable” will be displayed. When the Controller is switched from manual mode to automatic mode, the operation level’s first parameter will be displayed. When the Controller is switched to manual mode while already in manual mode, the command will be completed normally and the display will not change (the contents will not be refreshed).

● Writing Auto/Manual Status in EEPROM

The write mode determines whether the auto/manual status is written to EEPROM.

Write mode	Description
Backup mode	When the auto/manual mode is switched by communications, the auto/manual status is written to EEPROM.

Write mode	Description
RAM write mode	When the auto/manual mode is switched by communications, the auto/manual status is not written to EEPROM. The status can be written with the Controller key operations.

Note: When the auto/manual mode is switched with an operation command through communications and the Controller is in RAM write mode, the auto/manual status is not stored in EEPROM. Consequently, if the Controller is restarted by performing a software reset or turning the power OFF and ON again, the auto/manual mode is set to the last saved status.

◆ Switching to Manual Mode during Auto-tuning

If the mode is switched during auto-tuning (AT), the AT will be cancelled and the Controller will be switched to manual mode.

● Parameter Initialization

The present settings are returned to the default values and written to EEPROM. This command can be accepted in setup area 1 only. When this command is issued in setup area 0, an “operation error” will be generated.

Related information	Explanation (initialization values)
00	Default set values (See <i>SECTION 3 Communications Data for CompoWay/F and SYSWAY</i> for details.) (These settings are the same as the ones used when “FACT” is selected for the setting data’s set value initialization.)

● Alarm Latch Cancel

The applicable alarm latch can be cleared with the related information setting. The setting can be accepted in both setup area 0 and setup area 1. An operation error will occur if communications writing is disabled or if an EEPROM error occurs.

● Invert Direct/Reverse Operation

Inverting or not inverting direct/reverse operation can be selected with the related information setting. The setting can be accepted in both setup area 0 and setup area 1. The related information specifications are written to EEPROM according to the write mode settings. An operation error will occur in the following situations:

- When AT is being executed.
- When inverting direct/reverse operation is set for an event input.
- When executed in manual mode.

### ● Program Start

The simple program function can be reset/started with the related information setting. The setting can be accepted in both setup area 0 and setup area 1. An operation error will be generated if program start has been set in the event input.

### ● Setting Areas

Control operation is executed in setting area 0. In this state, you can perform operations that are permitted only during control or those that cause no problems even if control is in progress. These operations include reading PVs, writing SPs, and change RUN/STOP status.

Setting area 0, however, prohibits operations that affect control, including writing data at the initial setting level. (Reading setting data is always allowed.)

In setting area 1, control operation is stopped. In this state, you can perform operations that are not allowed in setting area 0. These operations include writing data at the initial setting level.

At power-ON, the Temperature Controller is set in setting area 0. To move to setting area 1, use the "move-to-setting area 1" command. To return to setting area 0, turn the power OFF and ON again, or use the "software reset" command.

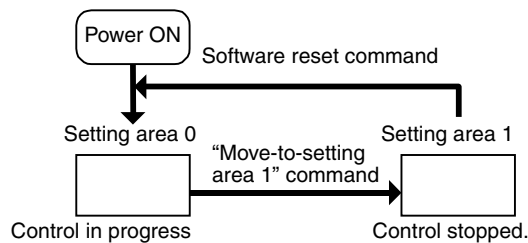

## ■ Echoback Test

### Command Frame

Slave address	Function code	Write start address	Test data	CRC-16
1	H'08	H'00 H'00	2	2 bytes

### Response Frame

Slave address	Function code	Write start address	Test data	CRC-16
1	H'08	H'00 H'00	2	2 bytes

\* When the command is executed normally, the response returns the same data sent in the command.

#### (1) Test Data

Enter any 2-byte hexadecimal data.

## (2) Response Code

Function code	Error code	Name	Description
H'88	H'03	Variable data error	The data following the function code was not the fixed data (H'00, H'00).
H'08	---	Normal completion	No errors were found.

## (3) Example Command and Response

The following example shows the command/response for an Echoback Test command.

(In this case, the test data is H'1234.)

(In this case, the slave address is H'01.)

Command: 01 08 00 00 12 34 ED 7C(CRC-16)  
 Response: 01 08 00 00 12 34 ED 7C(CRC-16)



# SECTION 6

## Communications Data for Modbus

This section lists the details of the communications data in the Modbus communications protocol.

6.1	Variable Area (Setting Range) List .....	6-2
6.2	Status and status 2 .....	6-17
	Status Structure .....	6-17
	Status 2 Structure .....	6-19
	Status Details .....	6-20
	Status 2 Details .....	6-21

## 6.1 Variable Area (Setting Range) List

- Four-byte Mode

One element uses 2 bytes of data (H'0000 to H'FFFF), so specify two-element units. Reading and writing in 4-byte units is executed by specifying an even address and specifying the number of elements in multiples of 2.

- Two-byte Mode

One element uses 2 bytes of data (H'0000 to H'FFFF), so specify one-element units. Reading and writing in 2-byte data units is executed by specifying 1-element units.

The following table lists the variable area. Items expressed in hexadecimal in the “Set (monitor) value” column are the setting range in the Modbus specifications. Values in parentheses “( )” are the actual setting range.

When there is a section reference for a setting item, refer to that reference for details.

Address		Parameter name	Setting (monitor) value	Level
Four-byte mode	Two-byte mode			
0000	2000	PV	Temperature: Use the specified range for each sensor. Analog: Scaling lower limit – 5% FS to Scaling upper limit + 5% FS	Operation
0002	2001	Status (See notes 1 and 2.)	See the 6.2 <i>Status and status 2</i> for details.	
0004	2002	Internal Set Point (See note 1.)	SP lower limit to SP upper limit	
0006	2003	Heater Current 1 Value Monitor	H'00000000 to H'00000226 (0.0 to 55.0)	
0008	2004	MV Monitor (Heating)	Standard: H'FFFFFFCE to H'0000041A (–5.0 to 105.0) Heating and cooling: H'00000000 to H'0000041A (0.0 to 105.0)	
000A	2005	MV Monitor (Cooling)	H'00000000 to H'0000041A (0.0 to 105.0)	
0106	2103	Set Point	SP lower limit to SP upper limit	
0108	2104	Alarm Value 1	H'FFFFFF831 to H'0000270F (–1999 to 9999)	
010A	2105	Alarm Value Upper Limit 1	H'FFFFFF831 to H'0000270F (–1999 to 9999)	
010C	2106	Alarm Value Lower Limit 1	H'FFFFFF831 to H'0000270F (–1999 to 9999)	

Note 1: Not displayed on the Controller display.

Note 2: In 2-byte mode, the rightmost 16 bits are read.



Address		Parameter name	Setting (monitor) value	Level
Four-byte mode	Two-byte mode			
010E	2107	Alarm Value 2	H'FFFFFF831 to H'0000270F (–1999 to 9999)	Operation
0110	2108	Alarm Value Upper Limit 2	H'FFFFFF831 to H'0000270F (–1999 to 9999)	
0112	2109	Alarm Value Lower Limit 2	H'FFFFFF831 to H'0000270F (–1999 to 9999)	
0404	2402	PV	Temperature: Use the specified range for each sensor. Analog: Scaling lower limit – 5% FS to Scaling upper limit + 5% FS	
0406	2403	Internal Set Point (See note 1.)	SP lower limit to SP upper limit	
0408	2404	Multi-SP Monitor	H'00000000 to H'00000003 (0 to 3)	
040C	2406	Status (See notes 1 and 2.)	See the 6.2 Status and status 2 for details.	
040E	2407	Status (See note 3.)	See the 6.2 Status and status 2 for details.	
0410	2408	Status 2 (See notes 1 and 2.)	See the 6.2 Status and status 2 for details.	
0412	2409	Status 2 (See notes 1 and 3.)	See the 6.2 Status and status 2 for details.	
0420	2410	Decimal Point Monitor	H'00000000 to H'00000003 (0 to 3)	
0422	2411	Control Output 1 ON/OFF Count Monitor	H'00000000 to H'0000270F (0 to 9999)	Advanced function setting
0424	2412	Control Output 2 ON/OFF Count Monitor	H'00000000 to H'0000270F (0 to 9999)	
0500	2500	Operation/Adjustment Protect	H'00000000 (0): No restrictions in operation and adjustment levels H'00000001 (1): Move to adjustment level is prohibited. H'00000002 (2): Display and change of only “PV” and “PV/SP” parameters is allowed. H'00000003 (3): Display of only “PV” and “PV/SP” parameters is allowed.	Protect
0502	2501	Initial Setting/Communications Protect	H'00000000 (0): Move to initial setting/communications setting level is allowed. (Move to advanced function setting level is displayed.) H'00000001 (1): Move to initial setting/communications setting level is allowed. (Move to advanced function setting level is not displayed.) H'00000002 (2): Move to initial setting/communications setting level is prohibited.	
0504	2502	Setting Change Protect	H'00000000 (0): OFF (Changing of setup on controller display is allowed.) H'00000001 (1): ON (Changing of setup on controller display is prohibited.)	
0506	2503	PF Key Protect	H'00000000 (0): OFF H'00000001 (1): ON	
0508	2504	Move to Protect Level	H'FFFFFF831 to H'0000270F (–1999 to 9999)	
050A	2505	Password to Move to Protect Level	H'FFFFFF831 to H'0000270F (–1999 to 9999) (Can only be set. The monitor value is always H'00000000.)	
050C	2506	Parameter Mask Enable	H'00000000 (0): OFF H'00000001 (1): ON	

Note 1: Not displayed on the Controller display.

Note 2: In 2-byte mode, the rightmost 16 bits are read.

Note 3: In 2-byte mode, the leftmost 16 bits are read.

Address		Parameter name	Setting (monitor) value	Level
Four-byte mode	Two-byte mode			
0600	2600	Manual MV	Standard: H'FFFFFFCE to H'0000041A (–5.0 to 105.0) Heating and cooling: H'FFFFFFBE6 to H'0000041A (–105.0 to 105.0)	Manual control
0602	2601	Set Point	SP lower limit to SP upper limit	Operation
0608	2604	Heater Current 1 Value Monitor	H'00000000 to H'00000226 (0.0 to 55.0)	
060A	2605	MV Monitor (Heating)	Standard: H'FFFFFFCE to H'0000041A (–5.0 to 105.0) Heating and cooling: H'00000000 to H'0000041A (0.0 to 105.0)	
060C	2606	MV Monitor (Cooling)	H'00000000 to H'0000041A (0.0 to 105.0)	
0700	2700	Cooling Coefficient	H'00000001 to H'0000270F (0.01 to 99.99)	Adjustment
0708	2704	Dead Band	H'FFFFFF831 to H'0000270F (–199.9 to 999.9 for TC/Pt universal input models) (–19.99 to 99.99 for Analog input models)	
070A	2705	Manual Reset Value	H'00000000 to H'000003E8 (0.0 to 100.0)	
070C	2706	Hysteresis (Heating)	H'00000001 to H'0000270F (0.1 to 999.9 for TC/Pt universal input models) (0.01 to 99.99 for Analog input models)	
070E	2707	Hysteresis (Cooling)	H'00000001 to H'0000270F (0.1 to 999.9 for TC/Pt universal input models) (0.01 to 99.99 for Analog input models)	
0710	2708	Control Period (Heating)	H'00000000 (0): 0.5 H'00000001 to H'00000063 (1 to 99)	Initial setting
0712	2709	Control Period (Cooling)	H'00000000 (0): 0.5 H'00000001 to H'00000063 (1 to 99)	
0718	270C	SP Ramp Time Unit	H'00000000 (0): EU/second H'00000001 (1): EU/minute H'00000002 (2): EU/hour	Advanced function setting
071A	270D	SP Ramp Set Value	H'00000000 (0): OFF H'00000001 to H'0000270F (1 to 9999)	Adjustment
071E	270F	MV at Stop	Standard: H'FFFFFFCE to H'0000041A (–5.0 to 105.0) Heating and cooling: H'FFFFFFBE6 to H'0000041A (–105.0 to 105.0)	
0722	2711	MV at PV Error	Standard: H'FFFFFFCE to H'0000041A (–5.0 to 105.0) Heating and cooling: H'FFFFFFBE6 to H'0000041A (–105.0 to 105.0)	
0726	2713	MV Change Rate Limit	H'00000000 to H'000003E8 (0.0 to 100.0)	
072C	2716	Lower Limit Temperature Input Shift Value	H'FFFFFF831 to H'0000270F (–199.9 to 999.9)	
0730	2718	Upper Limit Temperature Input Shift Value	H'FFFFFF831 to H'0000270F (–199.9 to 999.9)	
0734	271A	Heater Current 1 Value Monitor	H'00000000 to H'00000226 (0.0 to 55.0)	Operation
0736	271B	Heater Burnout Detection 1	H'00000000 to H'000001F4 (0.0 to 50.0)	Adjustment
0738	271C	Leakage Current 1 Monitor	H'00000000 to H'00000226 (0.0 to 55.0)	Operation

Address		Parameter name	Setting (monitor) value	Level
Four-byte mode	Two-byte mode			
073A	271D	HS Alarm 1	H'00000000 to H'000001F4 (0.0 to 50.0)	Adjustment
0746	2723	Temperature Input Shift	H'FFFFFF831 to H'0000270F (-199.9 to 999.9)	
0748	2724	Heater Current 2 Value Monitor	H'00000000 to H'00000226 (0.0 to 55.0)	Operation
074A	2725	Heater Burnout Detection 2	H'00000000 to H'000001F4 (0.0 to 50.0)	Adjustment
074C	2726	Leakage Current 2 Monitor	H'00000000 to H'00000226 (0.0 to 55.0)	Operation
074E	2727	HS Alarm 2	H'00000000 to H'000001F4 (0.0 to 50.0)	Adjustment
0750	2728	Soak Time Remain	H'00000000 to H'0000270F (0 to 9999)	Operation
0752	2729	Soak Time	H'00000001 to H'0000270F (1 to 9999)	Adjustment
0754	272A	Wait Band	H'00000000 (0): OFF H'00000001 to H'0000270F (0.1 to 999.9 for TC/Pt universal input models) (0.01 to 99.99 for Analog input models)	
0756	272B	Heater Overcurrent Detection 1	H'00000000 to H'000001F4 (0.0 to 50.0)	
0758	272C	Heater Overcurrent Detection 2	H'00000000 to H'000001F4 (0.0 to 50.0)	

Address		Parameter name	Setting (monitor) value	Level
Four-byte mode	Two-byte mode			
0800	2800	Input Digital Filter	H'00000000 to H'0000270F (0.0 to 999.9)	Advanced function setting
0810	2808	Extraction of Square Root Low-cut Point	H'00000000 to H'000003E8 (0.0 to 100.0)	Adjustment
0900	2900	SP 0	SP lower limit to SP upper limit	
0904	2902	Alarm Value 1	H'FFFFFF831 to H'0000270F (-1999 to 9999)	Operation
0906	2903	Alarm Value Upper Limit 1	H'FFFFFF831 to H'0000270F (-1999 to 9999)	
0908	2904	Alarm Value Lower Limit 1	H'FFFFFF831 to H'0000270F (-1999 to 9999)	
090A	2905	Alarm Value 2	H'FFFFFF831 to H'0000270F (-1999 to 9999)	
090C	2906	Alarm Value Upper Limit 2	H'FFFFFF831 to H'0000270F (-1999 to 9999)	
090E	2907	Alarm Value Lower Limit 2	H'FFFFFF831 to H'0000270F (-1999 to 9999)	
0910	2908	Alarm Value 3 (See note 1.)	H'FFFFFF831 to H'0000270F (-1999 to 9999)	
0912	2909	Alarm Value Upper Limit 3 (See note 1.)	H'FFFFFF831 to H'0000270F (-1999 to 9999)	
0914	290A	Alarm Value Lower Limit 3 (See note 1.)	H'FFFFFF831 to H'0000270F (-1999 to 9999)	
091C	290E	SP 1	SP lower limit to SP upper limit	
0938	291C	SP 2	SP lower limit to SP upper limit	
0954	292A	SP 3	SP lower limit to SP upper limit	
0A00	2A00	Proportional Band	H'00000001 to H'0000270F (0.1 to 999.9)	
0A02	2A01	Integral Time	H'00000000 to H'00000F9F (0 to 3999)	
0A04	2A02	Derivative Time	H'00000000 to H'00000F9F (0 to 3999) (Range when RT is "OFF:") H'00000000 to H'0000270F (0.0 to 999.9) (Range when RT is "ON:")	
0A0A	2A05	MV Upper Limit	Standard: MV lower limit + 0.1 to H'0000041A (MV lower limit + 0.1 to 105.0) Heating and cooling: H'00000000 to H'0000041A (0.0 to 105.0)	
0A0C	2A06	MV Lower Limit	Standard: H'FFFFFFCE to MV upper limit - 0.1 (-5.0 to MV upper limit - 0.1) Heating and cooling: H'FFFFFFBE6 to H'00000000 (-105.0 to 0.0)	

Note: The alarm function can also be used in Controllers without alarm output terminals. In this case, confirm alarm occurrences via the status data.

Note 1: Not displayed on the Controller display when Alarm 3 is not assigned to the output.

Address		Parameter name	Setting (monitor) value	Level
Four-byte mode	Two-byte mode			
0C00	2C00	Input Type (TC/Pt multi-input models) (See note.)	H'00000000 (0): Pt (–200 to 850°C/–300 to 1500°F) H'00000001 (1): Pt (–199.9 to 500.0°C/–199.9 to 900.0°F) H'00000002 (2): Pt (0.0 to 100.0°C/0.0 to 210.0°F) H'00000003 (3): JPt (–199.9 to 500.0°C/–199.9 to 900.0°F) H'00000004 (4): JPt (0.0 to 100.0°C/0.0 to 210.0°F) H'00000005 (5): K (–200 to 1300°C/–300 to 2300°F) H'00000006 (6): K (–20.0 to 500.0°C/0.0 to 900.0°F) H'00000007 (7): J (–100 to 850°C/–100 to 1500°F) H'00000008 (8): J (–20.0 to 400.0°C/0.0 to 750.0°F) H'00000009 (9): T (–200 to 400°C/–300 to 700°F) H'0000000A (10): T (–199.9 to 400.0°C/–199.9 to 700.0°F) H'0000000B (11): E (–200 to 600°C/–300 to 1100°F) H'0000000C (12): L (–100 to 850°C/–100 to 1500°F) H'0000000D (13): U (–200 to 400°C/–300 to 700°F) H'0000000E (14): U (–199.9 to 400.0°C/–199.9 to 700.0°F) H'0000000F (15): N (–200 to 1300°C/–300 to 2300°F) H'00000010 (16): R (0 to 1700°C/0 to 3000°F) H'00000011 (17): S (0 to 1700°C/0 to 3000°F) H'00000012 (18): B (100 to 1800°C/300 to 3200°F) H'00000013 (19): Infrared temperature sensor (K 140°F/60°C) H'00000014 (20): Infrared temperature sensor (K 240°F/120°C) H'00000015 (21): Infrared temperature sensor (K 280°F/140°C) H'00000016 (22): Infrared temperature sensor (K 440°F/220°C) H'00000017 (23): 0 to 50 mV H'00000018 (24): W (0 to 2300°C/0 to 3200°F) H'00000019 (25): PL II (0 to 1300°C/0 to 2300°F)	Initial setting
		Input Type (Analog input models, see note)	H'00000000 (0): 4 to 20 mA H'00000001 (1): 0 to 20 mA H'00000002 (2): 1 to 5 V H'00000003 (3): 0 to 5 V H'00000004 (4): 0 to 10 V	
0C02	2C01	Temperature Unit	H'00000000 (0): °C H'00000001 (1): °F	
0C12	2C09	Scaling Lower Limit	H'FFFFFF831 to scaling upper limit –1 (–1999 to scaling upper limit –1)	
0C16	2C0B	Scaling Upper Limit	Scaling lower limit +1 to H'0000270F (Scaling lower limit +1 to 9999)	
0C18	2C0C	Decimal Point (TC/Pt universal input models)	H'00000000 to 00000001 (0 to 1)	
		Decimal Point (Analog input models)	H'00000000 to 00000003 (0 to 3)	
0C1E	2C0F	PV Decimal Point Display	H'00000000 (0): OFF H'00000001 (1): ON	Advanced function setting

Note: The input type can be selected to match the connected sensor.

There are two input type specifications: Thermocouple/Resistance thermometer input and Analog input.

Address		Parameter name	Setting (monitor) value	Level
Four-byte mode	Two-byte mode			
0D06	2D03	Linear Current Output	H'00000000 (0): 4 to 20 mA H'00000001 (1): 0 to 20 mA	Initial setting
0D1E	2D0F	SP Upper Limit	The range of values (without decimal point) is as follows: Temperature: SP lower limit + 1 to Input range upper limit Analog: SP lower limit + 1 to scaling upper limit	
0D20	2D10	SP Lower Limit	The range of values (without decimal point) is as follows: Temperature: Input range lower limit to SP upper limit – 1 Analog: Scaling lower limit to SP upper limit – 1	
0D22	2D11	Standard or Heating/ Cooling	H'00000000 (0): Standard H'00000001 (1): Heating and cooling	
0D24	2D12	Direct/Reverse Operation	H'00000000 (0): Reverse operation H'00000001 (1): Direct operation	
0D28	2D14	PID ON/OFF	H'00000000 (0): ON/OFF H'00000001 (1): 2 PID control	
0D2A	2D15	ST	H'00000000 (0): OFF H'00000001 (1): ON	
0D2C	2D16	Program Pattern	H'00000000 (0): OFF H'00000001 (1): STOP H'00000002 (2): CONT	
0E00	2E00	Transfer Output Type	H'00000000 (0): OFF H'00000001 (1): Set point H'00000002 (2): Set point during SP ramp H'00000003 (3): PV H'00000004 (4): MV monitor (heating) H'00000005 (5): MV monitor (cooling)	

Address		Parameter name	Setting (monitor) value	Level
Four-byte mode	Two-byte mode			
0E0C	2E06	Control Output 1 Assignment	When control output 1 is a linear output: H'00000000 (0): Not assigned. H'00000001 (1): Control output (heating) H'00000002 (2): Control output (cooling) When control output 1 is an ON/OFF output: H'00000000 (0): Not assigned. H'00000001 (1): Control output (heating) H'00000002 (2): Control output (cooling) H'00000003 (3): Alarm 1 H'00000004 (4): Alarm 2 H'00000005 (5): Alarm 3 H'00000006 (6): Program end output (See note 1.) H'00000007 (7): Control output ON/OFF count alarm (See note 2.) H'00000008 (8): Work bit 1 H'00000009 (9): Work bit 2 H'0000000A (10): Work bit 3 H'0000000B (11): Work bit 4 H'0000000C (12): Work bit 5 H'0000000D (13): Work bit 6 H'0000000E (14): Work bit 7 H'0000000F (15): Work bit 8	Advanced function setting
0E0E	2E07	Control Output 2 Assignment	H'00000000 (0): Not assigned. H'00000001 (1): Control output (heating) H'00000002 (2): Control output (cooling) H'00000003 (3): Alarm 1 H'00000004 (4): Alarm 2 H'00000005 (5): Alarm 3 H'00000006 (6): Program end output (See note.) H'00000007 (7): Control output ON/OFF count alarm H'00000008 (8): Work bit 1 H'00000009 (9): Work bit 2 H'0000000A (10): Work bit 3 H'0000000B (11): Work bit 4 H'0000000C (12): Work bit 5 H'0000000D (13): Work bit 6 H'0000000E (14): Work bit 7 H'0000000F (15): Work bit 8	

Note 1: P.END (program end output) can be set even when the program pattern is set to OFF, but the function will be disabled.

Note 2: The output turns ON when the status of either the Control Output 1 ON/OFF Count Alarm or the Control Output 2 ON/OFF Count Alarm turns ON.

Address		Parameter name	Setting (monitor) value	Level
Four-byte mode	Two-byte mode			
0E14	2E0A	Event Input Assignment 1 (See note 1.)	H'00000000 (0): None H'00000001 (1): RUN/STOP (Cannot be set if the "Number of multi-SP uses" is set to 1 or 2.) H'00000002 (2): Auto/manual switch (Cannot be set if the "Number of multi-SP uses" is set to 1 or 2.) H'00000003 (3): Program Start (Cannot be set if the "Number of multi-SP uses" is set to 1 or 2.) (See note 3.) H'00000004 (4): Direct/reverse operation H'00000005 (5): None H'00000006 (6): 100% AT execute/cancel H'00000007 (7): 40% AT execute/cancel H'00000008 (8): Setting change enable/disable H'00000009 (9): Communications writing enable/disable H'0000000A (10): Alarm latch cancel	Advanced function setting
0E16	2E0B	Event Input Assignment 2 (See note 2.)	H'00000000 to H'0000000A (0 to 10) * Same as for Event Input Assignment 1.	
0E18	2E0C	Event Input Assignment 3	H'00000000 to H'0000000A (0 to 10) * Same as for Event Input Assignment 1.	
0E1A	2E0D	Event Input Assignment 4	H'00000000 to H'0000000A (0 to 10) * Same as for Event Input Assignment 1.	
0E20	2E10	Auxiliary Output 1 Assignment	H'00000000 (0): None H'00000001 (1): Control output (heating) H'00000002 (2): Control output (cooling) H'00000003 (3): Alarm 1 H'00000004 (4): Alarm 2 H'00000005 (5): Alarm 3 H'00000006 (6): Program end output (See note 5.) H'00000007 (7): Control output ON/OFF count alarm (See note 6.)	
0E22	2E11	Auxiliary Output 2 Assignment	H'00000000 to H'00000007 (0 to 7) (Same settings as the Auxiliary Output 1 Assignment)	
0E24	2E12	Auxiliary Output 3 Assignment	H'00000000 to H'00000007 (0 to 7) (Same settings as the Auxiliary Output 1 Assignment)	
0E28	2E14	Transfer Output Upper Limit	H'FFFFFF831 to H'0000270F (-1999 to 9999) (See note 4.)	Initial setting
0E2A	2E15	Transfer Output Lower Limit	H'FFFFFF831 to H'0000270F (-1999 to 9999) (See note 4.)	

Note 1: For Controllers with two event inputs (events 1 and 2), this cannot be set if the Number of Multi-SP Uses parameter is set to 1 or 2.

Note 2: For Controllers with two event inputs (events 1 and 2), this cannot be set if the Number of Multi-SP Uses parameter is set to 2.

Note 3: PRST (program start) can be set even when the program pattern is set to OFF, but the function will be disabled.

Note 4: The setting (monitor) range depends on the transfer output type setting. (See the setting data list for details.)

Note 5: P.END (program end output) can be set even when the program pattern is set to OFF, but the function will be disabled.

Note 6: The output turns ON when the status of either the Control Output 1 ON/OFF Count Alarm or the Control Output 2 ON/OFF Count Alarm turns ON.



Address		Parameter name	Setting (monitor) value	Level
Four-byte mode	Two-byte mode			
0E48	2E24	Extraction of Square Root Enable	H'00000000 (0): OFF H'00000001 (1): ON	Initial setting
0F00	2F00	Alarm 1 Type	H'00000000 (0): Alarm function OFF H'00000001 (1): Upper and lower-limit alarm H'00000002 (2): Upper-limit alarm H'00000003 (3): Lower-limit alarm H'00000004 (4): Upper and lower-limit range alarm H'00000005 (5): Upper and lower-limit alarm with standby sequence H'00000006 (6): Upper-limit alarm with standby sequence H'00000007 (7): Lower-limit alarm with standby sequence H'00000008 (8): Absolute-value upper-limit alarm H'00000009 (9): Absolute-value lower-limit alarm H'0000000A (10): Absolute-value upper-limit alarm with standby sequence H'0000000B (11): Absolute-value lower-limit alarm with standby sequence H'0000000C (12): LBA (Loop Burnout Alarm) H'0000000D (13): PV change rate alarm	
0F02	2F01	Alarm 1 Latch	H'00000000 (0): OFF H'00000001 (1): ON	Advanced function setting
0F04	2F02	Alarm 1 Hysteresis	H'00000001 to H'0000270F (0.1 to 999.9 for TC/Pt universal input models) (0.01 to 99.99 for Analog input models)	Initial setting
0F06	2F03	Alarm 2 Type	H'00000000 (0): Alarm function OFF H'00000001 (1): Upper and lower-limit alarm H'00000002 (2): Upper-limit alarm H'00000003 (3): Lower-limit alarm H'00000004 (4): Upper and lower-limit range alarm H'00000005 (5): Upper and lower-limit alarm with standby sequence H'00000006 (6): Upper-limit alarm with standby sequence H'00000007 (7): Lower-limit alarm with standby sequence H'00000008 (8): Absolute-value upper-limit alarm H'00000009 (9): Absolute-value lower-limit alarm H'0000000A (10): Absolute-value upper-limit alarm with standby sequence H'0000000B (11): Absolute-value lower-limit alarm with standby sequence H'0000000C (12): No alarm function H'0000000D (13): PV change rate alarm	
0F08	2F04	Alarm 2 Latch	H'00000000 (0): OFF H'00000001 (1): ON	Advanced function setting
0F0A	2F05	Alarm 2 Hysteresis	H'00000001 to H'0000270F (0.1 to 999.9 for TC/Pt universal input models) (0.01 to 99.99 for Analog input models)	Initial setting
0F0C	2F06	Alarm 3 Type (See note.)	Same settings as the alarm 2 type.	
0F0E	2F07	Alarm 3 Latch (See note.)	H'00000000 (0): OFF H'00000001 (1): ON	Advanced function setting
0F10	2F08	Alarm 3 Hysteresis (See note.)	H'00000001 to H'0000270F (0.1 to 999.9 for TC/Pt universal input models) (0.01 to 99.99 for Analog input models)	Initial setting
0F18	2F0C	Standby Sequence Reset	H'00000000 (0): Condition A H'00000001 (1): Condition B	Advanced function setting
0F1A	2F0D	Auxiliary Output 1 Open in Alarm	H'00000000 (0): Close in alarm H'00000001 (1): Open in alarm	
0F1C	2F0E	Auxiliary Output 2 Open in Alarm	H'00000000 (0): Close in alarm H'00000001 (1): Open in alarm	
0F1E	2F0F	Auxiliary Output 3 Open in Alarm (See note.)	H'00000000 (0): Close in alarm H'00000001 (1): Open in alarm	

Note: Not displayed on the Controller display when Alarm 3 is not assigned to the output.

Address		Parameter name	Setting (monitor) value	Level
Four-byte mode	Two-byte mode			
0F22	2F11	Alarm 1 ON delay	H'00000000 to H'000003E7 (0 to 999)	Advanced function setting
0F24	2F12	Alarm 2 ON delay	H'00000000 to H'000003E7 (0 to 999)	
0F26	2F13	Alarm 3 ON delay (See note.)	H'00000000 to H'000003E7 (0 to 999)	
0F2A	2F15	Alarm 1 OFF delay	H'00000000 to H'000003E7 (0 to 999)	
0F2C	2F16	Alarm 2 OFF delay	H'00000000 to H'000003E7 (0 to 999)	
0F2E	2F17	Alarm 3 OFF delay (See note.)	H'00000000 to H'000003E7 (0 to 999)	
1000	3000	PV/SP Display Screen Selection	H'00000000 (0): PV/SP H'00000001 (1): PV/SP/multi-SP PV/SP/MV H'00000002 (2): PV/SP/MV PV/SP/multi-SP H'00000003 (3): PV/SP/multi-SP H'00000004 (4): PV/SP/MV H'00000005 (5): PV/SP/multi-SP PV/SP/soak time remain H'00000006 (6): PV/SP/MV PV/SP/soak time remain H'00000007 (7): PV/SP/soak time remain	
1002	3001	MV Display Selection	H'00000000 (0): MV (heating) H'00000001 (1): MV (cooling)	

Note: Not displayed on the Controller display when Alarm 3 is not assigned to the output.



Address		Parameter name	Setting (monitor) value	Level
Four-byte mode	Two-byte mode			
1100	3100	Protocol Setting (See note.)	H'00000000 (0): CompoWay/F (SYSWAY) H'00000001 (1): Modbus	Communications setting
1102	3101	Communications Unit No. (See note.)	H'00000000 to H'00000063 (0 to 99)	
1104	3102	Communications Baud Rate (See note.)	H'00000000 (0): 1.2 H'00000001 (1): 2.4 H'00000002 (2): 4.8 H'00000003 (3): 9.6 H'00000004 (4): 19.2 H'00000005 (5): 38.4 H'00000006 (6): 57.6	
1106	3103	Communications Data Length (See note.)	H'00000007 (7): 7 H'00000008 (8): 8	
1108	3104	Communications Stop Bits (See note.)	H'00000001 (1): 1 H'00000002 (2): 2	
110A	3105	Communications Parity (See note.)	H'00000000 (0): None H'00000001 (1): Even H'00000002 (2): Odd	
110C	3106	Send Data Wait Time (See note.)	H'00000000 to H'00000063 (0 to 99)	
1200	3200	PF Setting	H'00000000 (0): None H'00000001 (1): Run H'00000002 (2): Stop H'00000003 (3): RUN/STOP H'00000004 (4): 100% AT execute H'00000005 (5): 40% AT execute H'00000006 (6): Alarm latch cancel H'00000007 (7): Auto/manual switch H'00000008 (8): Monitor/setting item	
1204	3202	Monitor/Setting Item 1	H'00000000 (0): Disabled H'00000001 (1): PV/SP/multi-SP H'00000002 (2): PV/SP/MV H'00000003 (3): PV/SP/soak time remain H'00000004 (4): Proportional band (P) H'00000005 (5): Integral time (I) H'00000006 (6): Derivative time (D) H'00000007 (7): Alarm value 1 H'00000008 (8): Alarm value upper limit 1 H'00000009 (9): Alarm value lower limit 1 H'0000000A (10): Alarm value 2 H'0000000B (11): Alarm value upper limit 2 H'0000000C (12): Alarm value lower limit 2 H'0000000D (13): Alarm value 3 H'0000000E (14): Alarm value upper limit 3 H'0000000F (15): Alarm value lower limit 3	
1206	3203	Monitor/Setting Item 2	H'00000000 to H'0000000F (0 to 15) * Same as for Monitor/Setting Item 1.	
1208	3204	Monitor/Setting Item 3	H'00000000 to H'0000000F (0 to 15) * Same as for Monitor/Setting Item 1.	
120A	3205	Monitor/Setting Item 4	H'00000000 to H'0000000F (0 to 15) * Same as for Monitor/Setting Item 1.	
120C	3206	Monitor/Setting Item 5	H'00000000 to H'0000000F (0 to 15) * Same as for Monitor/Setting Item 1.	

Note: After communications parameters have been changed, reset the Controller to enable them.

Address		Parameter name	Setting (monitor) value	Level
Four-byte mode	Two-byte mode			
130A	3305	Cold Junction Compensation Method	H'00000000 (0): OFF H'00000001 (1): ON	Advanced function setting
1314	330A	$\alpha$	H'00000000 to H'00000064 (0.00 to 1.00)	
131E	330F	AT Calculated Gain	H'00000001 to H'00000064 (0.1 to 10.0)	
1320	3310	AT Hysteresis	H'00000001 to H'0000270F (0.1 to 999.9 for TC/Pt universal input models) (0.01 to 9.99 for Analog input models)	
1322	3311	Limit Cycle MV Amplitude	H'00000032 to H'000001F4 (5.0 to 50.0)	
1328	3314	Heater Burnout Latch	H'00000000 (0): OFF H'00000001 (1): ON	
132A	3315	Heater Burnout Hysteresis	H'00000001 to H'000001F4 (0.1 to 50.0)	
132C	3316	HS Alarm Latch	H'00000000 (0): OFF H'00000001 (1): ON	
132E	3317	HS Alarm Hysteresis	H'00000001 to H'000001F4 (0.1 to 50.0)	
1334	331A	Number of Multi-SP Uses	H'00000000 (0): No multi-SP H'00000001 (1): 2SP H'00000002 (2): 4SP	
1336	331B	Multi-SP Uses	H'00000000 (0): OFF H'00000001 (1): ON	Advanced function setting
1338	331C	HB ON/OFF	H'00000000 (0): OFF H'00000001 (1): ON	
133A	331D	MB Command Logic Switching (See note.)	H'00000000 (0): OFF H'00000001 (1): ON	
133C	331E	Input Error Output	H'00000000 (0): OFF H'00000001 (1): ON	
133E	331F	Input Shift Type	H'00000000 (0): Temperature input 1-point shift H'00000001 (1): Temperature input 2-point shift	
1340	3320	MV at Stop and Error Addition	H'00000000 (0): OFF H'00000001 (1): ON	
1342	3321	ST Stable Range	H'00000001 to H'0000270F (0.1 to 999.9)	
1344	3322	RT	H'00000000 (0): OFF H'00000001 (1): ON	
1346	3323	HS Alarm Use	H'00000000 (0): OFF H'00000001 (1): ON	
1348	3324	LBA Detection Time	H'00000000 to H'0000270F (0 to 9999)	
134A	3325	LBA Level	H'00000001 to H'0000270F (0.1 to 999.9 for TC/Pt universal input models) (0.01 to 99.99 for Analog input models)	
134C	3326	LBA Band	H'00000000 to H'0000270F (0.0 to 999.9 for TC/Pt universal input models) (0.00 to 99.99 for Analog input models)	
134E	3327	Soak Time Unit	H'00000000 (0): Minutes H'00000001 (1): Hours	
1350	3328	Alarm SP Selection	H'00000000 (0): Set point during SP ramp H'00000001 (1): Set point	

Note: The logic of the Modbus Write Variable operation command is not affected.

Address		Parameter name	Setting (monitor) value	Level
Four-byte mode	Two-byte mode			
1356	332B	Manual MV Limit Enable	H'00000000 (0): OFF H'00000001 (1): ON	Advanced function setting
135A	332D	PV Rate of Change Calculation Period	H'00000001 to H'000003E7 (1 to 999)	
135C	332E	Automatic Cooling Coefficient Adjustment	H'00000000 (0): OFF H'00000001 (1): ON	
135E	332F	Heater Overcurrent Use	H'00000000 (0): OFF H'00000001 (1): ON	
1360	3330	Heater Overcurrent Latch	H'00000000 (0): OFF H'00000001 (1): ON	
1362	3331	Heater Overcurrent Hysteresis	H'00000001 to H'000001F4 (0.1 to 50.0)	
1364	3332	Control Output 1 ON/OFF Count Alarm Set Value	H'00000000 to H'0000270F (0 to 9999)	
1366	3333	Control Output 2 ON/OFF Count Alarm Set Value	H'00000000 to H'0000270F (0 to 9999)	



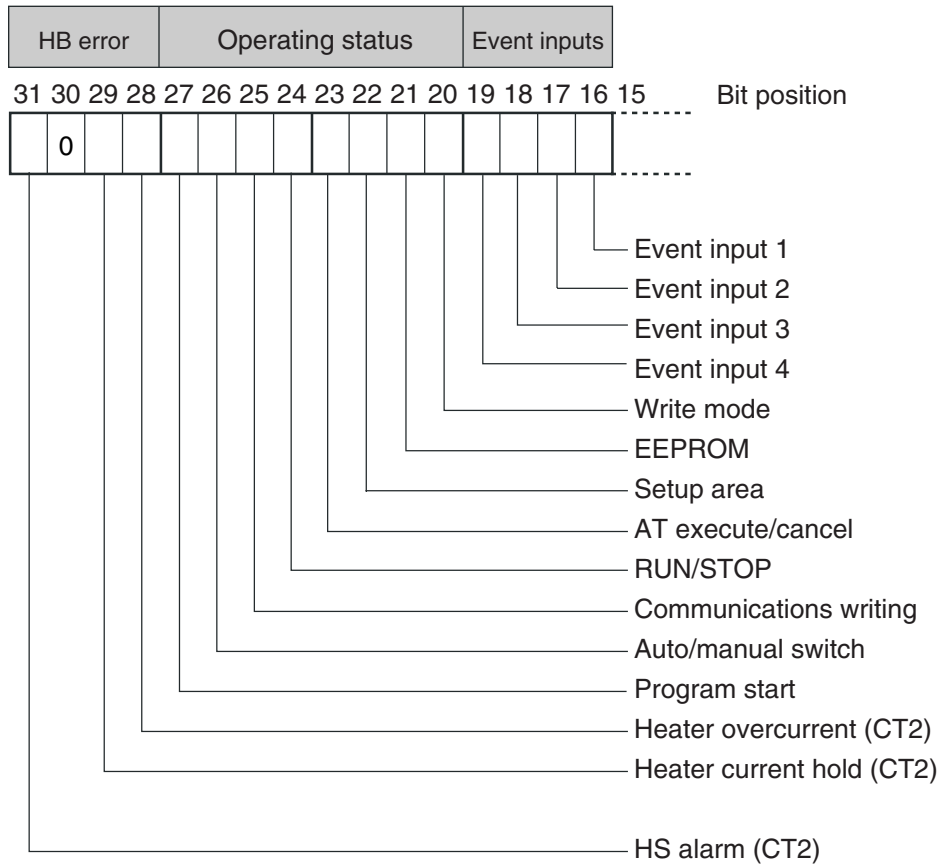



## ■ Status 2 Structure

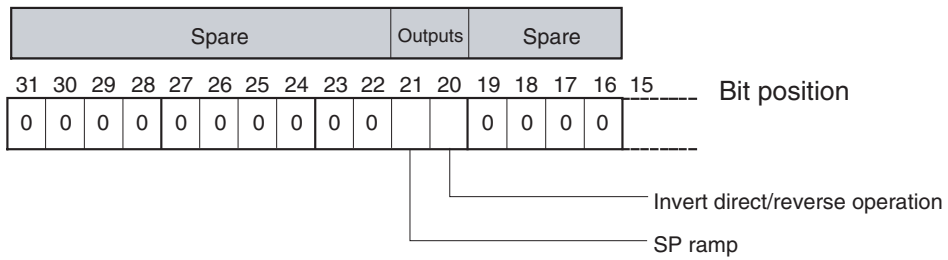
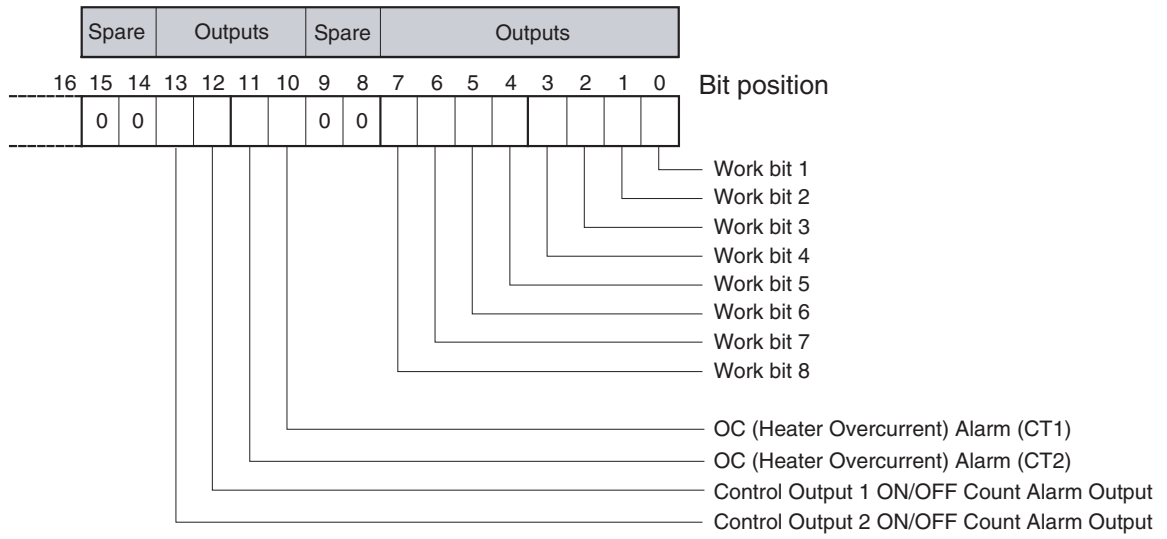

## ■ Status Details

Bit position		Status	Bit Description	
			0	1
Status (lower word)	0	Heater overcurrent (CT1)	Not generated	Generated
	1	Heater current hold (CT1) (See note 1.)	Update	Hold
	2	A/D converter error	Not generated	Generated
	3	HS alarm (CT1)	OFF	ON
	4	Spare	OFF	---
	5	Display range exceeded	Not generated	Generated
	6	Input error	Not generated	Generated
	7	Spare	OFF	---
	8	Control output (heating)	OFF	ON
	9	Control output (cooling)	OFF	ON
	10	HB (heater burnout) alarm (CT1)	OFF	ON
	11	HB (heater burnout) alarm (CT2)	OFF	ON
	12	Alarm 1	OFF	ON
	13	Alarm 2	OFF	ON
	14	Alarm 3	OFF	ON
15	Program end output	OFF	ON	
Status (upper word)	16	Event input 1	OFF	ON
	17	Event input 2	OFF	ON
	18	Event input 3	OFF	ON
	19	Event input 4	OFF	ON
	20	Write mode	Backup mode	RAM write mode
	21	EEPROM	RAM = EEPROM	RAM ≠ EEPROM
	22	Setup area	Setup area 0	Setup area 1
	23	AT execute/cancel	AT canceled	AT execution in progress
	24	RUN/STOP	Run	Stop
	25	Communications writing	OFF (disabled)	ON (enabled)
	26	Auto/manual switch	Automatic mode	Manual mode
	27	Program start	Reset	Start
	28	Heater overcurrent (CT2)	Not generated	Generated
	29	Heater current hold (CT2) (See note 1.)	Update	Hold
	30	Spare	OFF	---
	31	HS alarm (CT2)	OFF	ON

Note 1: When the control output ON time is less than 100 ms, the bit is set to “1” and the heater current is held at the last current value.

Note 2: “Spare” bits are always OFF.

Note 3: When read in setup area 1, the status of the bits will be as follows:

- Overcurrent: Last value held
- A/D converter error: Last value held
- Input error: Last value held
- HB and HS outputs: Cleared
- Program end output: Cleared
- Current hold: Last value held
- Display range exceeded: Last value held
- Heating and cooling outputs: Cleared
- Alarm outputs: Cleared

## ■ Status 2 Details

Bit position		Status	Bit Description	
			0	1
Status (lower word)	0	Work bit 1	OFF	ON
	1	Work bit 2	OFF	ON
	2	Work bit 3	OFF	ON
	3	Work bit 4	OFF	ON
	4	Work bit 5	OFF	ON
	5	Work bit 6	OFF	ON
	6	Work bit 7	OFF	ON
	7	Work bit 8	OFF	ON
	8	Spare	OFF	---
	9	Spare	OFF	---
	10	OC (Heater Overcurrent) Alarm (CT1)	OFF	ON
	11	OC (Heater Overcurrent) Alarm (CT2)	OFF	ON
	12	Control Output 1 ON/OFF Count Alarm Output	OFF	ON
	13	Control Output 2 ON/OFF Count Alarm Output	OFF	ON
	14	Spare	OFF	---
15	Spare	OFF	---	
Status (upper word)	16	Spare	OFF	---
	17	Spare	OFF	---
	18	Spare	OFF	---
	19	Spare	OFF	---
	20	Invert direct/reverse operation	Not invert	Invert
	21	SP ramp	OFF	During SP ramp
	22	Spare	OFF	---
	23	Spare	OFF	---
	24	Spare	OFF	---
	25	Spare	OFF	---
	26	Spare	OFF	---
	27	Spare	OFF	---
	28	Spare	OFF	---
	29	Spare	OFF	---
	30	Spare	OFF	---
	31	Spare	OFF	---

Note 1. "Spare" bits are always OFF.

Note 2. When read in setup area 1, the status of the bits will be as follows:

- Overcurrent Output: Cleared
- Control Output 1 ON/OFF Count Alarm: Cleared
- Control Output 2 ON/OFF Count Alarm: Cleared
- Work bits 1 to 8: Last value held
- SP ramp: Last value held



# Appendix

ASCII List.....	A-2
Troubleshooting.....	A-3

# ASCII List

	b8								
	b7	0	0	0	0	1	1	1	1
	b6	0	0	1	1	0	0	1	1
	b5	0	1	0	1	0	1	0	1

	b8	b7	b6	b5	b4	b3	b2	b1
Even parity ↑	0	0	0	0	0	0	0	0
	0	0	0	0	1	1	1	1
	0	0	1	1	0	0	0	0
	0	0	1	0	0	0	0	0
	0	1	0	0	0	0	0	0
	0	1	0	1	0	0	0	0
	0	1	1	0	0	0	0	0
	0	1	1	1	0	0	0	0
	1	0	0	0	0	0	0	0
	1	0	0	1	0	0	0	0
	1	0	1	0	0	0	0	0
	1	0	1	1	0	0	0	0
	1	1	0	0	0	0	0	0
	1	1	0	1	0	0	0	0
	1	1	1	0	0	0	0	0
	1	1	1	1	0	0	0	0

R \ C	0	1	2	3	4	5	6	7
0	NUL	DLE	SPACE	0	@	P	`	p
1	SOH	DC1	!	1	A	Q	a	q
2	STX	DC2	"	2	B	R	b	r
3	ETX	DC3	#	3	C	S	c	s
4	EOT	DC4	\$	4	D	T	d	t
5	ENQ	NAK	%	5	E	U	e	u
6	ACK	SYN	&	6	F	V	f	v
7	BEL	ETB	'	7	G	W	g	w
8	BS	CAN	(	8	H	X	h	x
9	HT	EM	)	9	I	Y	i	y
A	LF	SUB	*	:	J	Z	j	z
B	VT	ESC	+	;	K	[	k	{
C	FF	FS	,	<	L	\	l	
D	CR	GS	-	=	M	]	m	}
E	SO	RS	.	>	N	^	n	~
F	SI	US	/	?	O	_	o	DEL

# Troubleshooting

## ■ Before Requesting Repairs

If communications are not functioning properly, check the items in the following table before requesting repairs. If normal operation cannot be restored even after checking everything, return the product to your OMRON representative.

**Problem: Communications are not possible or communications errors occur.**

Item	Confirmation	Page
The communications wiring is not correct.	Correct the wiring.	1-4
The communications line has become disconnected.	Connect the communications line securely and tighten the screws.	---
The communications cable is broken.	Replace the cable.	---
The communications cable is too long.	The total cable length is 500 m maximum for RS-485 and 15 m maximum for RS-232C communications. To extend the communications distance for RS-232C communications, use OMRONs Z3R Optical Interface.	1-4 1-5 1-6
The wrong communications cable has been used.	E5CN, E5EN, or E5AN: Use a shielded, AWG24 to AWG14 (cross-sectional area of 0.205 to 2.081 mm <sup>2</sup> ) twisted-pair cable for the communications cable. E5GN: Use a shielded, AWG24 to AWG18 (cross-sectional area of 0.205 to 0.823 mm <sup>2</sup> ) twisted-pair cable for the communications cable.	1-4 1-5 1-6
Too many communications devices are connected to the communications path for RS-485 communications.	When 1:N, RS-485 communications are used, a maximum of 32 nodes may be connected, including the host node.	1-4
An end node has not been set at each end of the communications line for RS-485 communications.	Set or connect terminating resistance at each end of the line. If the E5CN, E5AN, E5EN, or E5GN is the end node, 120-Ω (1/2-W) terminating resistance is used. Be sure that the combined resistance with the host device is 54 Ω minimum.	1-4
The specified power supply voltage is not being supplied to the Controller.	Supply the specified power supply voltage.	---
The specified power supply voltage is not being supplied to an Interface Converter (e.g., the K3SC).	Supply the specified power supply voltage.	---
The same baud rate and communications method are not being used by all of the Controllers, host devices, and other nodes on the same communications line.	Set the same values for the following on all nodes: baud rate, protocol, data length, stop bits, and parity.	1-3
The unit number specified in the command frame is different from the unit number set for the Controller.	Use the same unit number.	2-2 4-2 5-2
The same unit number as the Controller is being used for another node on the same communications line for RS-485 communications.	Set each unit number for only one node.	1-4
There is a mistake in programming in the host device.	Use a line monitor to check the commands. Check operation using a sample program.	---

Item	Confirmation	Page
The host device is detecting the absence of a response as an error before it receives the response from the Controller.	Shorten the send data wait time in the Controller or increase the response wait time in the host device.	1-7
The host device is detecting the absence of a response as an error after broadcasting a command or sending a software reset command (except for SYSWAY).	The Controller does not return responses for broadcast or software reset commands.	2-2 2-14 5-2 5-14
The host device sent another command before receiving a response from the Controller.	Always read the response after sending a command (except for broadcast or software reset commands).	---
The host device sent the next command too soon after receiving a response from the Controller.	Wait for at least 2 ms after receiving a response before sending the next command.	1-3
The communications line became unstable when the Controller's power was turned ON or interrupted, and the host device read the unstable status as data.	Initialize the reception buffer in the host device before sending the first command and after turning OFF the power to the Controller.	---
The communications data was corrupted by noise from the environment.	<p>Try using a slower baud rate.</p> <p>Separate the communications cable from the source of noise.</p> <p>Use a shielded, twisted-pair cable for the communications cable.</p> <p>Use as short a communications cable as possible and do not lay or loop extra cable.</p> <p>Do not run the communications cable parallel to a power line to prevent inductive noise.</p> <p>If noise countermeasures are difficult to implement, use an Optical Interface.</p>	---



# Index

<b>A</b>	addresses CompoWay/F ..... 2-7 Modbus ..... 5-7 area definitions ..... 2-6 ASCII list ..... A-2	<b>F</b>	FCS ..... 4-2 FINS ..... 1-2, 2-3 function code ..... 5-2 function list ..... 5-6
<b>B</b>	BCC ..... 1-3, 2-2, 2-3	<b>I</b>	interface ..... 1-4
<b>C</b>	command descriptions ..... 4-5 command frame CompoWay/F ..... 2-2 Modbus ..... 5-2 SYSWAY ..... 4-2 command lists SYSWAY ..... 4-4 command text ..... 2-2, 2-6 communications baud rate ..... 1-7, 1-8 communications data CompoWay/F ..... 2-4 CompoWay/F and SYSWAY ..... 3-1 SYSWAY ..... 4-3 communications data length ..... 1-7, 1-8 communications methods ..... 1-2 communications parameter setup ..... 1-7 communications parameters ..... 1-7, 1-8 communications parity ..... 1-7, 1-9 communications protocol ..... 1-7, 1-8 communications specifications ..... 1-3 communications stop bits ..... 1-7, 1-9 communications unit number ..... 1-7, 1-8 communications writing selection ..... 4-9 CompoWay/F ..... 1-2, 2-1 CRC-16 ..... 5-3	<b>M</b>	Modbus ..... 1-2, 5-1, 6-1
<b>D</b>	data format CompoWay/F ..... 2-2 Modbus ..... 5-2 SYSWAY ..... 4-2	<b>N</b>	no response Modbus ..... 5-5 node number ..... 2-2 number of elements CompoWay/F ..... 2-7 Modbus ..... 5-8
<b>E</b>	Echoback Test CompoWay/F ..... 2-8, 2-18 Modbus ..... 5-6, 5-20 end code CompoWay/F ..... 2-3, 2-4 SYSWAY ..... 4-3, 4-6 error code ..... 5-5 ETX ..... 2-2	<b>O</b>	Operation Command CompoWay/F ..... 2-8, 2-19
		<b>P</b>	PDU structure ..... 2-6 protocol setting ..... 1-8
		<b>R</b>	Read Controller Attributes CompoWay/F ..... 2-7, 2-16 Read Controller Status ..... 2-8, 2-17 Read Initial Status ..... 4-4 Read Process Value ..... 4-4, 4-5 Read Set Values and MV Monitor SYSWAY ..... 4-7 Read Variable Area CompoWay/F ..... 2-7, 2-9 response code list CompoWay/F ..... 2-26 response frame CompoWay/F ..... 2-3 Modbus ..... 5-4 SYSWAY ..... 4-3 RS-485 ..... 1-4
		<b>S</b>	send data wait time ..... 1-7, 1-9

services details	
CompoWay/F .....	2-9
list (CompoWay/F) .....	2-7
Modbus .....	5-9
set values	
Modbus .....	5-8
SID .....	2-2, 2-4
slave address .....	5-2
status .....	3-15, 6-17
STX .....	2-2
SYSWAY .....	4-1

## T

transmission procedure .....	1-3
type code (variable type) .....	2-6

## V

variable area	
Modbus .....	5-7
Variable Area (setting range) list	
CompoWay/F and SYSWAY .....	3-2
Modbus .....	6-2
variable type .....	2-6, 2-7

## W

wiring .....	1-4
Write Set Values	
SYSWAY .....	4-6
Write Variable Area	
CompoWay/F .....	2-10

## Revision History

A manual revision code appears as a suffix to the catalog number on the front cover of the manual.

Cat. No. H158-E1-02



The following table outlines the changes made to the manual during each revision. Page numbers refer to the previous version.

Revision code	Date	Revised content
01	January 2008	Original production
02	September 2009	Added the E5GN.

# Terms and Conditions of Sale

1. **Offer; Acceptance.** These terms and conditions (these "Terms") are deemed part of all quotes, agreements, purchase orders, acknowledgments, price lists, catalogs, manuals, brochures and other documents, whether electronic or in writing, relating to the sale of products or services (collectively, the "Products") by Omron Electronics LLC and its subsidiary companies ("Omron"). Omron objects to any terms or conditions proposed in Buyer's purchase order or other documents which are inconsistent with, or in addition to, these Terms.
2. **Prices; Payment Terms.** All prices stated are current, subject to change without notice by Omron. Omron reserves the right to increase or decrease prices on any unshipped portions of outstanding orders. Payments for Products are due net 30 days unless otherwise stated in the invoice.
3. **Discounts.** Cash discounts, if any, will apply only on the net amount of invoices sent to Buyer after deducting transportation charges, taxes and duties, and will be allowed only if (i) the invoice is paid according to Omron's payment terms and (ii) Buyer has no past due amounts.
4. **Interest.** Omron, at its option, may charge Buyer 1-1/2% interest per month or the maximum legal rate, whichever is less, on any balance not paid within the stated terms.
5. **Orders.** Omron will accept no order less than \$200 net billing.
6. **Governmental Approvals.** Buyer shall be responsible for, and shall bear all costs involved in, obtaining any government approvals required for the importation or sale of the Products.
7. **Taxes.** All taxes, duties and other governmental charges (other than general real property and income taxes), including any interest or penalties thereon, imposed directly or indirectly on Omron or required to be collected directly or indirectly by Omron for the manufacture, production, sale, delivery, importation, consumption or use of the Products sold hereunder (including customs duties and sales, excise, use, turnover and license taxes) shall be charged to and remitted by Buyer to Omron.
8. **Financial.** If the financial position of Buyer at any time becomes unsatisfactory to Omron, Omron reserves the right to stop shipments or require satisfactory security or payment in advance. If Buyer fails to make payment or otherwise comply with these Terms or any related agreement, Omron may (without liability and in addition to other remedies) cancel any unshipped portion of Products sold hereunder and stop any Products in transit until Buyer pays all amounts, including amounts payable hereunder, whether or not then due, which are owing to it by Buyer. Buyer shall in any event remain liable for all unpaid accounts.
9. **Cancellation; Etc.** Orders are not subject to rescheduling or cancellation unless Buyer indemnifies Omron against all related costs or expenses.
10. **Force Majeure.** Omron shall not be liable for any delay or failure in delivery resulting from causes beyond its control, including earthquakes, fires, floods, strikes or other labor disputes, shortage of labor or materials, accidents to machinery, acts of sabotage, riots, delay in or lack of transportation or the requirements of any government authority.
11. **Shipping; Delivery.** Unless otherwise expressly agreed in writing by Omron:
  - a. Shipments shall be by a carrier selected by Omron; Omron will not drop ship except in "break down" situations.
  - b. Such carrier shall act as the agent of Buyer and delivery to such carrier shall constitute delivery to Buyer;
  - c. All sales and shipments of Products shall be FOB shipping point (unless otherwise stated in writing by Omron), at which point title and risk of loss shall pass from Omron to Buyer; provided that Omron shall retain a security interest in the Products until the full purchase price is paid;
  - d. Delivery and shipping dates are estimates only; and
  - e. Omron will package Products as it deems proper for protection against normal handling and extra charges apply to special conditions.
12. **Claims.** Any claim by Buyer against Omron for shortage or damage to the Products occurring before delivery to the carrier must be presented in writing to Omron within 30 days of receipt of shipment and include the original transportation bill signed by the carrier noting that the carrier received the Products from Omron in the condition claimed.
13. **Warranties.** (a) **Exclusive Warranty.** Omron's exclusive warranty is that the Products will be free from defects in materials and workmanship for a period of twelve months from the date of sale by Omron (or such other period expressed in writing by Omron). Omron disclaims all other warranties, express or implied. (b) **Limitations.** OMRON MAKES NO WARRANTY OR REPRESENTATION, EXPRESS OR IMPLIED, ABOUT NON-INFRINGEMENT, MERCHANTABILITY OR FITNESS FOR A PARTICULAR PURPOSE OF THE PRODUCTS. BUYER ACKNOWLEDGES THAT IT ALONE HAS DETERMINED THAT THE PRODUCTS WILL SUITABLY MEET THE REQUIREMENTS OF THEIR INTENDED USE. Omron further disclaims all warranties and responsibility of any type for claims or expenses based on infringement by the Products or otherwise of any intellectual property right. (c) **Buyer Remedy.** Omron's sole obligation hereunder shall be, at Omron's election, to (i) replace (in the form originally shipped with Buyer responsible for labor charges for removal or replacement thereof) the non-complying Product, (ii) repair the non-complying Product, or (iii) repay or credit Buyer an amount equal to the purchase price of the non-complying Product; provided that in no event shall Omron be responsible for warranty, repair, indemnity or any other claims or expenses regarding the Products unless Omron's analysis confirms that the Products were properly handled, stored, installed and maintained and not subject to contamination, abuse, misuse or inappropriate modification. Return of any Products by Buyer must be approved in writing by Omron before shipment. Omron Companies shall not be liable for the suitability or unsuitability or the results from the use of Products in combination with any electrical or electronic components, circuits, system assemblies or any other materials or substances or environments. Any advice, recommendations or information given orally or in writing, are not to be construed as an amendment or addition to the above warranty. See <http://www.omron247.com> or contact your Omron representative for published information.
14. **Limitation on Liability; Etc.** OMRON COMPANIES SHALL NOT BE LIABLE FOR SPECIAL, INDIRECT, INCIDENTAL, OR CONSEQUENTIAL DAMAGES, LOSS OF PROFITS OR PRODUCTION OR COMMERCIAL LOSS IN ANY WAY CONNECTED WITH THE PRODUCTS, WHETHER SUCH CLAIM IS BASED IN CONTRACT, WARRANTY, NEGLIGENCE OR STRICT LIABILITY. Further, in no event shall liability of Omron Companies exceed the individual price of the Product on which liability is asserted.
15. **Indemnities.** Buyer shall indemnify and hold harmless Omron Companies and their employees from and against all liabilities, losses, claims, costs and expenses (including attorney's fees and expenses) related to any claim, investigation, litigation or proceeding (whether or not Omron is a party) which arises or is alleged to arise from Buyer's acts or omissions under these Terms or in any way with respect to the Products. Without limiting the foregoing, Buyer (at its own expense) shall indemnify and hold harmless Omron and defend or settle any action brought against such Companies to the extent based on a claim that any Product made to Buyer specifications infringed intellectual property rights of another party.
16. **Property; Confidentiality.** Any intellectual property in the Products is the exclusive property of Omron Companies and Buyer shall not attempt to duplicate it in any way without the written permission of Omron. Notwithstanding any charges to Buyer for engineering or tooling, all engineering and tooling shall remain the exclusive property of Omron. All information and materials supplied by Omron to Buyer relating to the Products are confidential and proprietary, and Buyer shall limit distribution thereof to its trusted employees and strictly prevent disclosure to any third party.
17. **Export Controls.** Buyer shall comply with all applicable laws, regulations and licenses regarding (i) export of products or information; (ii) sale of products to "forbidden" or other proscribed persons; and (iii) disclosure to non-citizens of regulated technology or information.
18. **Miscellaneous.** (a) **Waiver.** No failure or delay by Omron in exercising any right and no course of dealing between Buyer and Omron shall operate as a waiver of rights by Omron. (b) **Assignment.** Buyer may not assign its rights hereunder without Omron's written consent. (c) **Law.** These Terms are governed by the law of the jurisdiction of the home office of the Omron company from which Buyer is purchasing the Products (without regard to conflict of law principles). (d) **Amendment.** These Terms constitute the entire agreement between Buyer and Omron relating to the Products, and no provision may be changed or waived unless in writing signed by the parties. (e) **Severability.** If any provision hereof is rendered ineffective or invalid, such provision shall not invalidate any other provision. (f) **Setoff.** Buyer shall have no right to set off any amounts against the amount owing in respect of this invoice. (g) **Definitions.** As used herein, "including" means "including without limitation"; and "Omron Companies" (or similar words) mean Omron Corporation and any direct or indirect subsidiary or affiliate thereof.

## Certain Precautions on Specifications and Use

1. **Suitability of Use.** Omron Companies shall not be responsible for conformity with any standards, codes or regulations which apply to the combination of the Product in the Buyer's application or use of the Product. At Buyer's request, Omron will provide applicable third party certification documents identifying ratings and limitations of use which apply to the Product. This information by itself is not sufficient for a complete determination of the suitability of the Product in combination with the end product, machine, system, or other application or use. Buyer shall be solely responsible for determining appropriateness of the particular Product with respect to Buyer's application, product or system. Buyer shall take application responsibility in all cases but the following is a non-exhaustive list of applications for which particular attention must be given:
  - (i) Outdoor use, uses involving potential chemical contamination or electrical interference, or conditions or uses not described in this document.
  - (ii) Use in consumer products or any use in significant quantities.
  - (iii) Energy control systems, combustion systems, railroad systems, aviation systems, medical equipment, amusement machines, vehicles, safety equipment, and installations subject to separate industry or government regulations.
  - (iv) Systems, machines and equipment that could present a risk to life or property. Please know and observe all prohibitions of use applicable to this Product.

NEVER USE THE PRODUCT FOR AN APPLICATION INVOLVING SERIOUS RISK TO LIFE OR PROPERTY OR IN LARGE QUANTITIES WITHOUT ENSURING THAT THE SYSTEM AS A WHOLE HAS BEEN DESIGNED TO ADDRESS THE RISKS, AND THAT THE OMRON'S PRODUCT IS PROPERLY RATED AND INSTALLED FOR THE INTENDED USE WITHIN THE OVERALL EQUIPMENT OR SYSTEM.
2. **Programmable Products.** Omron Companies shall not be responsible for the user's programming of a programmable Product, or any consequence thereof.
3. **Performance Data.** Data presented in Omron Company websites, catalogs and other materials is provided as a guide for the user in determining suitability and does not constitute a warranty. It may represent the result of Omron's test conditions, and the user must correlate it to actual application requirements. Actual performance is subject to the Omron's Warranty and Limitations of Liability.
4. **Change in Specifications.** Product specifications and accessories may be changed at any time based on improvements and other reasons. It is our practice to change part numbers when published ratings or features are changed, or when significant construction changes are made. However, some specifications of the Product may be changed without any notice. When in doubt, special part numbers may be assigned to fix or establish key specifications for your application. Please consult with your Omron's representative at any time to confirm actual specifications of purchased Product.
5. **Errors and Omissions.** Information presented by Omron Companies has been checked and is believed to be accurate; however, no responsibility is assumed for clerical, typographical or proofreading errors or omissions.

# OMRON

## **OMRON ELECTRONICS LLC • THE AMERICAS HEADQUARTERS**

Schaumburg, IL USA • 847.843.7900 • 800.556.6766 • [www.omron247.com](http://www.omron247.com)

### **OMRON CANADA, INC. • HEAD OFFICE**

Toronto, ON, Canada • 416.286.6465 • 866.986.6766 • [www.omron247.com](http://www.omron247.com)

### **OMRON ELETRÔNICA DO BRASIL LTDA • HEAD OFFICE**

São Paulo, SP, Brasil • 55.11.2101.6300 • [www.omron.com.br](http://www.omron.com.br)

### **OMRON ELECTRONICS MEXICO SA DE CV • HEAD OFFICE**

Apodaca, N.L. • 52.811.156.99.10 • 001.800.556.6766 • [mela@omron.com](mailto:mela@omron.com)

### **OMRON ARGENTINA • SALES OFFICE**

Cono Sur • 54.11.4783.5300

### **OMRON CHILE • SALES OFFICE**

Santiago • 56.9.9917.3920

### **OTHER OMRON LATIN AMERICA SALES**

54.11.4783.5300

© 2009 Omron Electronics LLC

Cat. No. H158-E1-02

09/09

Specifications are subject to change without notice.