

**SYSMAC CS and CJ Series  
CS1W-EIP21 (100Base-TX)  
CJ1W-EIP21 (100Base-TX)  
CJ2H-CPU6□-EIP (100Base-TX)  
CJ2M-CPU3□ (100Base-TX/10Base-T)  
EtherNet/IP Units**

**OPERATION MANUAL**

**OMRON**



**CS1W-EIP21 (100Base-TX)**  
**CJ1W-EIP21 (100Base-TX)**  
**CJ2H-CPU6□-EIP (100Base-TX)**  
**CJ2M-CPU3□ (100Base-TX/10Base-T)**  
**EtherNet/IP Units**

**Operation Manual**

*Revised October 2012*





## Notice:

OMRON products are manufactured for use according to proper procedures by a qualified operator and only for the purposes described in this manual.

The following conventions are used to indicate and classify precautions in this manual. Always heed the information provided with them. Failure to heed precautions can result in injury to people or damage to property.

 **DANGER** Indicates an imminently hazardous situation which, if not avoided, will result in death or serious injury. Additionally, there may be severe property damage.

 **WARNING** Indicates a potentially hazardous situation which, if not avoided, could result in death or serious injury. Additionally, there may be severe property damage.

 **Caution** Indicates a potentially hazardous situation which, if not avoided, may result in minor or moderate injury, or property damage.

## OMRON Product References

All OMRON products are capitalized in this manual. The word “Unit” is also capitalized when it refers to an OMRON product, regardless of whether or not it appears in the proper name of the product.

The abbreviation “Ch,” which appears in some displays and on some OMRON products, often means “word” and is abbreviated “Wd” in documentation in this sense.

The abbreviation “PLC” means Programmable Controller. “PC” is used, however, in some Programming Device displays to mean Programmable Controller.

## Visual Aids

The following headings appear in the left column of the manual to help you locate different types of information.

**Note** Indicates information of particular interest for efficient and convenient operation of the product.

**1,2,3...** 1. Indicates lists of one sort or another, such as procedures, checklists, etc.

## Trademarks and Copyrights

EtherNet/IP is a registered trademark of the ODVA (Open DeviceNet Vendor Association).

Ethernet is a trademark of the Xerox Corporation.

Microsoft, Windows, Windows NT, Windows 2000, Windows XP, and Windows Vista are registered trademarks of the Microsoft Corporation.

Other names of systems or products that appear in this document are trademarks or registered trademarks of the respective company.

### © OMRON, 2007

All rights reserved. No part of this publication may be reproduced, stored in a retrieval system, or transmitted, in any form, or by any means, mechanical, electronic, photocopying, recording, or otherwise, without the prior written permission of OMRON.

No patent liability is assumed with respect to the use of the information contained herein. Moreover, because OMRON is constantly striving to improve its high-quality products, the information contained in this manual is subject to change without notice. Every precaution has been taken in the preparation of this manual. Nevertheless, OMRON assumes no responsibility for errors or omissions. Neither is any liability assumed for damages resulting from the use of the information contained in this publication.



# TABLE OF CONTENTS

<b>PRECAUTIONS</b> .....	<b>xxiii</b>
1 Intended Audience .....	xxiv
2 General Precautions .....	xxiv
3 Safety Precautions .....	xxiv
4 Operating Environment Precautions .....	xxvi
5 Application Precautions .....	xxvi
6 Conformance to EC Directives .....	xxviii
<b>SECTION 1</b>	
<b>Overview of EtherNet/IP</b> .....	<b>1</b>
1-1 EtherNet/IP Unit Features .....	2
1-2 Devices Required for Constructing a Network .....	4
1-3 Support Software Required to Construct a Network .....	4
1-4 Communications Services Overview .....	6
1-5 Network Configurator Overview .....	10
<b>SECTION 2</b>	
<b>Unit Specifications</b> .....	<b>13</b>
2-1 EtherNet/IP Unit and Built-in EtherNet/IP Port Specifications .....	14
2-2 Nomenclature and Functions .....	22
2-3 Selecting the Network Devices .....	29
<b>SECTION 3</b>	
<b>Installation and Initial Setup</b> .....	<b>33</b>
3-1 Overview of Initial Setup Procedures .....	34
3-2 Switch Settings .....	36
3-3 Mounting to a PLC .....	38
3-4 Network Installation .....	41
3-5 Connecting to the Network .....	44
3-6 Creating I/O Tables .....	46
3-7 Setting the Local IP Address .....	50
3-8 TCP/IP and Link Settings .....	52
3-9 Tag Data Link Parameters .....	58
3-10 Other Parameters .....	62
3-11 Communications Test .....	66

# TABLE OF CONTENTS

## SECTION 4

<b>Memory Allocations</b> .....	<b>69</b>
4-1 Overview of Memory Allocated to the EtherNet/IP Unit .....	70
4-2 CIO Area Allocations .....	72
4-3 DM Area Allocations .....	85
4-4 User Settings Area .....	87
4-5 Auxiliary Area Data .....	90

## SECTION 5

<b>Determining IP Addresses</b> .....	<b>93</b>
5-1 IP Addresses .....	94
5-2 IP Addresses in FINS Communications .....	96
5-3 Private and Global Addresses .....	108

## SECTION 6

<b>Tag Data Link Functions</b> .....	<b>113</b>
6-1 Overview of Tag Data Links .....	114
6-2 Setting Tag Data Links .....	123
6-3 Ladder Programming with Tag Data Links .....	185

## SECTION 7

<b>Message Communications Functions</b> .....	<b>189</b>
7-1 Overview .....	190
7-2 FINS Message Communications .....	192
7-3 Explicit Message Communications .....	194
7-4 Message Communications Specifications .....	195
7-5 Message Communications Error Indications .....	196
7-6 Message Communications Errors .....	197

## SECTION 8

<b>FINS Communications</b> .....	<b>199</b>
8-1 Overview of FINS Communications .....	200
8-2 FINS/UDP Method .....	202
8-3 FINS/TCP Method .....	204
8-4 Routing Tables .....	209
8-5 Using FINS Applications .....	213
8-6 Communicating between OMRON PLCs .....	222
8-7 Precautions on High Traffic in FINS Communications .....	234



# TABLE OF CONTENTS

## SECTION 9

### **Message Communications . . . . . 235**

- 9-1 Sending Explicit Messages . . . . . 236
- 9-2 Receiving Explicit Messages . . . . . 249

## SECTION 10

### **Communications Performance and Communications Load 263**

- 10-1 Communications System . . . . . 264
- 10-2 Adjusting the Communications Load . . . . . 270
- 10-3 I/O Response Time in Tag Data Links . . . . . 285
- 10-4 Tag Data Link Performance for CJ2M Built-in EtherNet/IP Ports . . . . . 293
- 10-5 Message Service Transmission Delay . . . . . 296

## SECTION 11

### **FTP Server . . . . . 303**

- 11-1 Overview and Specifications . . . . . 304
- 11-2 FTP Server Function Details . . . . . 305
- 11-3 Using the FTP Server Function . . . . . 307
- 11-4 FTP Server Application Example . . . . . 309
- 11-5 Using FTP Commands . . . . . 310
- 11-6 Checking FTP Status . . . . . 316
- 11-7 Using File Memory . . . . . 317
- 11-8 FTP File Transfer Time . . . . . 322
- 11-9 Host Computer Application Example . . . . . 323

## SECTION 12

### **Automatic Clock Adjustment Function . . . . . 325**

- 12-1 Automatic Clock Adjustment . . . . . 326
- 12-2 Using the Automatic Clock Adjustment Function . . . . . 327
- 12-3 Automatic Clock Adjustment Switch . . . . . 330
- 12-4 Automatic Clock Adjustment Error Processing . . . . . 330

## SECTION 13

### **Maintenance and Unit Replacement . . . . . 333**

- 13-1 Maintenance and Replacement . . . . . 334
- 13-2 Simple Backup Function . . . . . 335
- 13-3 Using the Backup Tool . . . . . 338

# TABLE OF CONTENTS

## SECTION 14

### **Troubleshooting and Error Processing. . . . . 341**

14-1	Checking Status with the Network Configurator. . . . .	342
14-2	Using the LED Indicators and Display for Troubleshooting. . . . .	349
14-3	Connection Status Codes and Error Processing. . . . .	360
14-4	Error Log Function . . . . .	366
14-5	Troubleshooting. . . . .	370
14-6	Troubleshooting with FINS Response Codes . . . . .	373

## **Appendices**

A	CS/CJ-series Ethernet Unit Function Comparison . . . . .	377
B	Ethernet Network Parameters . . . . .	379
C	TCP Status Transitions . . . . .	381
D	CIP Message Communications . . . . .	383
E	FINS Commands Addressed to EtherNet/IP Units or Built-in EtherNet/IP Ports . . . . .	393
F	EDS File Management . . . . .	421
G	Precautions for Using Windows XP, Vista, or Windows 7 . . . . .	425
H	Setting Example for Using Tag Data Links with the CJ2M . . . . .	429

### **Index. . . . . 431**

### **Revision History . . . . . 439**

## ***About this Manual:***

This manual describes the operation of the CS/CJ-series EtherNet/IP Units and the built-in EtherNet/IP ports on a CJ2 CPU Unit for constructing applications and includes the sections described below.

Please read this manual carefully and be sure you understand the information provided before attempting to install or operate the EtherNet/IP Unit or built-in EtherNet/IP port. Be sure to read the precautions provided in the following section.

**Precautions** provides general precautions for using the CS/CJ-series EtherNet/IP Units and built-in EtherNet/IP ports.

**Section 1** introduces the functions and protocols used in EtherNet/IP Unit or built-in EtherNet/IP port communications services.

**Section 2** provides the specifications of EtherNet/IP Units and introduces recommended network configuration devices.

**Section 3** explains how to install and make the initial settings required for operation of the EtherNet/IP Unit or built-in EtherNet/IP port.

**Section 4** describes the words allocated in the CIO Area and the DM Area for EtherNet/IP Units or built-in EtherNet/IP ports.

**Section 5** explains how to manage and use IP addresses.

**Section 6** describes tag data link functions and related Network Configurator operations.

**Section 7** describes message communications using FINS messages and explicit messages.

**Section 8** provides information on communicating on EtherNet/IP Systems and interconnected networks using FINS commands. The information provided in the section deals only with FINS communications in reference to EtherNet/IP Units or built-in EtherNet/IP ports.

**Section 9** describes message communications using FINS commands sent from the ladder program in the CPU Unit of the PLC.

**Section 10** describes the communications performance in an EtherNet/IP network, and shows how to estimate the I/O response times and transmission delays.

**Section 11** describes the functions provided by the FTP server.

**Section 12** provides an overview of the automatic clock adjustment function, including details on specifications, required settings, operations from CX-Programmer, and troubleshooting.

**Section 13** describes cleaning, inspection, and Unit replacement procedures, as well as the Simple Backup Function.

**Section 14** describes error processing, periodic maintenance operations, and troubleshooting procedures needed to keep the EtherNet/IP network operating properly. We recommend reading through the error processing procedures before operation so that operating errors can be identified and corrected more quickly.

**Appendices** provide information on EtherNet/IP network parameters, the buffer configuration, TCP status transitions, ASCII characters, maintenance, and inspections.

## Relevant Manuals

The following table lists CS- and CJ-series manuals that contain information relevant to EtherNet/IP Units or built-in EtherNet/IP ports.

Manual number	Model	Name	Contents
W465	CS1W-EIP21 CJ1W-EIP21 CJ2H-CPU6□-EIP CJ2M-CPU3□	EtherNet/IP Units Operation Manual (this manual)	Provides information on operating and installing EtherNet/IP Units, including details on basic settings, tag data links, and FINS communications.  Refer to the <i>Communications Commands Reference Manual (W342)</i> for details on FINS commands that can be sent to CS-series and CJ-series CPU Units when using the FINS communications service.  Refer to the <i>Ethernet Units Operation Manual Construction of Applications (W421)</i> for details on constructing host applications that use FINS communications.
W420	CS1W-ETN21 CJ1W-ETN21	Ethernet Units Operation Manual Construction of Networks	Provides information on operating and installing 100Base-TX Ethernet Units, including details on basic settings and FINS communications. Refer to the <i>Communications Commands Reference Manual (W342)</i> for details on FINS commands that can be sent to CS-series and CJ-series CPU Units when using the FINS communications service.
W421	CS1W-ETN21 CJ1W-ETN21	Ethernet Units Operation Manual Construction of Applications	Provides information on constructing host applications for 100Base-TX Ethernet Units, including functions for sending/receiving mail, socket service, automatic clock adjustment, FTP server functions, and FINS communications.
W495	CJ1W-EIP21	CJ-series EtherNet/IP Units Operation Manual for NJ-series CPU Unit	Information on using an EtherNet/IP Unit that is connected to an NJ-series CPU Unit is provided. Information is provided on the basic setup, tag data links, and other features. Use this manual together with the <i>NJ-series CPU Unit Hardware User's Manual (Cat. No. W500)</i> and <i>NJ-series CPU Unit Software User's Manual (Cat. No. W501)</i> .
W343	CS1W-ETN01 CS1W-ETN11 CJ1W-ETN11	Ethernet Units Operation Manual	Describes the installation and operation of the 10Base-5 and 10Base-T Ethernet Units.
W342	CS1G/H-CPU□□-EV1 CS1G/H-CPU□□H CS1D-CPU□□H CS1D-CPU□□S CJ1H-CPU□□H-R CJ1G-CPU□□ CJ1M-CPU□□ CJ1G-CPU□□P CJ1G/H-CPU□□H CJ2H-CPU6□-EIP CJ2H-CPU6□ CJ2M-CPU□□ CS1W-SCU□□-V1 CS1W-SCB□□-V1 CJ1W-SCU□□-V1 CP1H-X□□□□-□ CP1H-XA□□□□-□ CP1H-Y□□□□-□ CP1L-M/L□□□□-□ CP1E-E□□D□-□ CP1E-N□□D□-□ NSJ□-□□□□(B)-G5D NSJ□-□□□□(B)-M3D	Communications Commands Reference Manual	Describes the C-series (Host Link) and FINS communications commands used when sending communications commands to CS-series, CJ-series, CP-series, and SYS-MAC One NSJ-series CPU Units.

Manual number	Model	Name	Contents
W472	CJ2H-CPU6□-EIP CJ2H-CPU6□ CJ2M-CPU□□	CJ-series CJ2 CPU Unit Hardware User's Manual	Provides hardware information for the CJ2 CPU Units. Information is included on features, system configuration, component names, component functions, installation, setting procedures, and troubleshooting.  Use together with the <i>CJ-series CJ2 CPU Unit Software User's Manual (W473)</i> .
W473	CJ2H-CPU6□-EIP CJ2H-CPU6□ CJ2M-CPU□□	CJ-series CJ2 CPU Unit Software User's Manual	Provides software information for the CJ2 CPU Units. Information is included on CPU Unit operation, internal memory, programming, setting procedures, and CPU Unit functions.  Use together with the <i>CJ-series CJ2 CPU Unit Hardware User's Manual (W472)</i> .
W474	CJ2H-CPU6□-EIP CJ2H-CPU6□ CJ2M-CPU□□ CJ1G/H-CPU□□H CS1G/H-CPU□□-EV1 CS1D-CPU□□H CS1D-CPU□□S CJ1H-CPU□□H-R CJ1G/H-CPU□□H CJ1G-CPU□□P CJ1M-CPU□□ CJ1G-CPU□□ NSJ□-□□□□(B)-G5D NSJ□-□□□□(B)-M3D	Programmable Controllers Instructions Reference Manual	Provides detailed descriptions of the instructions. When programming, use this manual together with the manuals for your CPU Unit.
W339	CS1G/H-CPU□□H	Programmable Controllers Operation Manual	Provides an outline of, and describes the design, installation, maintenance, and other basic operations for the CS-series PLCs. Information is also included on features, system configuration, wiring, I/O memory allocations, and troubleshooting.  Use together with the <i>Programmable Controllers Programming Manual (W394)</i> .
W393	CJ1H-CPU□□H-R CJ1G/H-CPU□□H CJ1G-CPU□□P CJ1G-CPU□□ CJ1M-CPU□□	Programmable Controllers Operation Manual	Provides an outline of, and describes the design, installation, maintenance, and other basic operations for the CJ-series PLCs. Information is also included on features, system configuration, wiring, I/O memory allocations, and troubleshooting.  Use together with the <i>Programmable Controllers Programming Manual (W394)</i> .
W394	CS1G/H-CPU□□-EV1 CS1G/H-CPU□□H CS1D-CPU□□H CS1D-CPU□□S CJ1H-CPU□□H-R CJ1G-CPU□□ CJ1G/H-CPU□□H CJ1G-CPU□□P CJ1M-CPU□□ NSJ□-□□□□(B)-G5D NSJ□-□□□□(B)-M3D	Programmable Controllers Programming Manual	Describes programming, tasks, file memory, and other functions for the CS-series, CJ-series, and NS-J-series PLCs.  Use together with the <i>Programmable Controllers Operation Manual (W339 for CS-series PLCs and W393 for CJ-series PLCs)</i> .
W463	CXONE-AL□□C-V4 CXONE-AL□□D-V4 CXONE-LT□□C-V4	CX-One Setup Manual	Describes the setup procedures for the CX-One. Information is also provided on the operating environment for the CX-One.
W446	CXONE-AL□□C-V4 CXONE-AL□□D-V4	CX-Programmer Operation Manual	Provides information on how to use the CX-Programmer, a Windows-based programming device. Use together with the <i>Programmable Controllers Operation Manual (W339 for CS-series PLCs and W393 for CJ-series PLCs)</i> , <i>Programmable Controllers Programming Manual (W394)</i> and the <i>Programmable Controllers Instructions Reference Manual (W474)</i> to perform programming.

Manual number	Model	Name	Contents
W464	CXONE-AL□□C-V4/ CXONE-AL□□D-V4	CS/CJ/CP/NSJ-series CX-Integrator Ver. 2.□ Operation Manual	Describes the operating procedures of the CX-Integrator that can be used to set up and monitor networks.



**WARNING** Failure to read and understand the information provided in this manual may result in personal injury or death, damage to the product, or product failure. Please read each section in its entirety and be sure you understand the information provided in the section and related sections before attempting any of the procedures or operations given.

## ***Read and Understand this Manual***

Please read and understand this manual before using the product. Please consult your OMRON representative if you have any questions or comments.

## ***Warranty and Limitations of Liability***

### ***WARRANTY***

OMRON's exclusive warranty is that the products are free from defects in materials and workmanship for a period of one year (or other period if specified) from date of sale by OMRON.

OMRON MAKES NO WARRANTY OR REPRESENTATION, EXPRESS OR IMPLIED, REGARDING NON-INFRINGEMENT, MERCHANTABILITY, OR FITNESS FOR PARTICULAR PURPOSE OF THE PRODUCTS. ANY BUYER OR USER ACKNOWLEDGES THAT THE BUYER OR USER ALONE HAS DETERMINED THAT THE PRODUCTS WILL SUITABLY MEET THE REQUIREMENTS OF THEIR INTENDED USE. OMRON DISCLAIMS ALL OTHER WARRANTIES, EXPRESS OR IMPLIED.

### ***LIMITATIONS OF LIABILITY***

OMRON SHALL NOT BE RESPONSIBLE FOR SPECIAL, INDIRECT, OR CONSEQUENTIAL DAMAGES, LOSS OF PROFITS OR COMMERCIAL LOSS IN ANY WAY CONNECTED WITH THE PRODUCTS, WHETHER SUCH CLAIM IS BASED ON CONTRACT, WARRANTY, NEGLIGENCE, OR STRICT LIABILITY.

In no event shall the responsibility of OMRON for any act exceed the individual price of the product on which liability is asserted.

IN NO EVENT SHALL OMRON BE RESPONSIBLE FOR WARRANTY, REPAIR, OR OTHER CLAIMS REGARDING THE PRODUCTS UNLESS OMRON'S ANALYSIS CONFIRMS THAT THE PRODUCTS WERE PROPERLY HANDLED, STORED, INSTALLED, AND MAINTAINED AND NOT SUBJECT TO CONTAMINATION, ABUSE, MISUSE, OR INAPPROPRIATE MODIFICATION OR REPAIR.

# ***Application Considerations***

## ***SUITABILITY FOR USE***

OMRON shall not be responsible for conformity with any standards, codes, or regulations that apply to the combination of products in the customer's application or use of the products.

At the customer's request, OMRON will provide applicable third party certification documents identifying ratings and limitations of use that apply to the products. This information by itself is not sufficient for a complete determination of the suitability of the products in combination with the end product, machine, system, or other application or use.

The following are some examples of applications for which particular attention must be given. This is not intended to be an exhaustive list of all possible uses of the products, nor is it intended to imply that the uses listed may be suitable for the products:

- Outdoor use, uses involving potential chemical contamination or electrical interference, or conditions or uses not described in this manual.
- Nuclear energy control systems, combustion systems, railroad systems, aviation systems, medical equipment, amusement machines, vehicles, safety equipment, and installations subject to separate industry or government regulations.
- Systems, machines, and equipment that could present a risk to life or property.

Please know and observe all prohibitions of use applicable to the products.

**NEVER USE THE PRODUCTS FOR AN APPLICATION INVOLVING SERIOUS RISK TO LIFE OR PROPERTY WITHOUT ENSURING THAT THE SYSTEM AS A WHOLE HAS BEEN DESIGNED TO ADDRESS THE RISKS, AND THAT THE OMRON PRODUCTS ARE PROPERLY RATED AND INSTALLED FOR THE INTENDED USE WITHIN THE OVERALL EQUIPMENT OR SYSTEM.**

## ***PROGRAMMABLE PRODUCTS***

OMRON shall not be responsible for the user's programming of a programmable product, or any consequence thereof.



## **Disclaimers**

### ***CHANGE IN SPECIFICATIONS***

Product specifications and accessories may be changed at any time based on improvements and other reasons.

It is our practice to change model numbers when published ratings or features are changed, or when significant construction changes are made. However, some specifications of the products may be changed without any notice. When in doubt, special model numbers may be assigned to fix or establish key specifications for your application on your request. Please consult with your OMRON representative at any time to confirm actual specifications of purchased products.

### ***DIMENSIONS AND WEIGHTS***

Dimensions and weights are nominal and are not to be used for manufacturing purposes, even when tolerances are shown.

### ***PERFORMANCE DATA***

Performance data given in this manual is provided as a guide for the user in determining suitability and does not constitute a warranty. It may represent the result of OMRON's test conditions, and the users must correlate it to actual application requirements. Actual performance is subject to the OMRON Warranty and Limitations of Liability.

### ***ERRORS AND OMISSIONS***

The information in this manual has been carefully checked and is believed to be accurate; however, no responsibility is assumed for clerical, typographical, or proofreading errors, or omissions.



# Unit Versions of CS/CJ-series

## Unit Versions

A “unit version” has been introduced to manage Units in the CS/CJ Series according to differences in functionality accompanying Unit upgrades.

### Notation of Unit Versions on Products

The unit version is given to the right of the lot number on the nameplate of the products for which unit versions are being managed, as shown below.

#### ■ CS1W-EIP21/CJ1W-EIP21

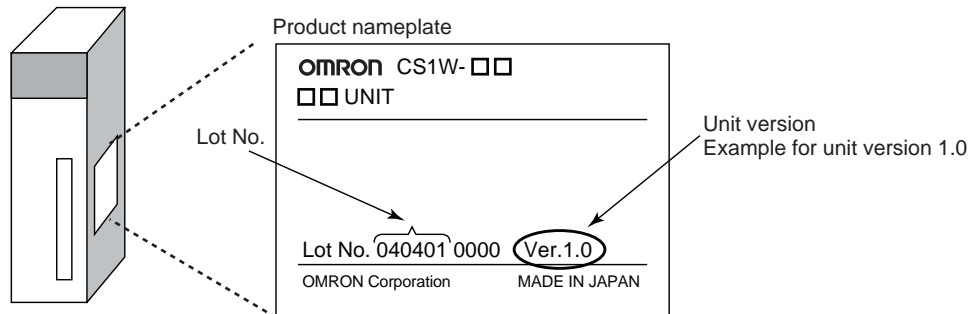

#### ■ CJ2H-CPU□□-EIP/CJ2M-CPU3□

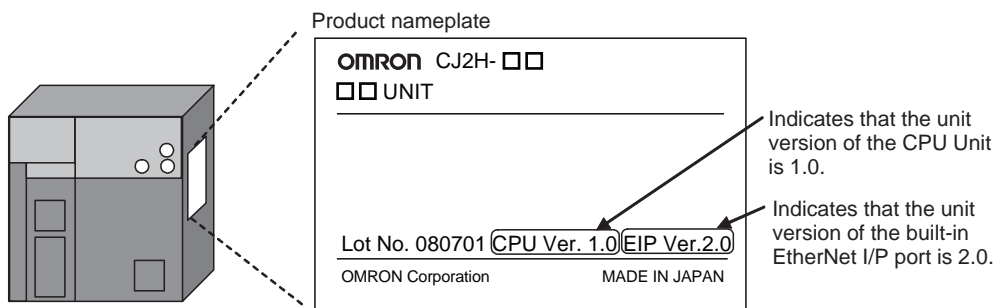

In this manual, the version of the EtherNet/IP port built into the CJ2H-CPU□□-EIP/CJ2M-CPU3□ CPU Unit is given as the unit version.

### Confirming Unit Versions with Support Software

CX-Programmer version 4.0 can be used to confirm the unit version using the **Unit Manufacturing Information**.

**Note** The unit versions of Pre-Ver.1.0 Units cannot be confirmed in **Unit Manufacturing Information**. The following dialog box is displayed.



In the *IO Table* Window, right-click and select **Unit Manufacturing information - CPU Unit**.

The following *Unit Manufacturing information* Dialog Box will be displayed.

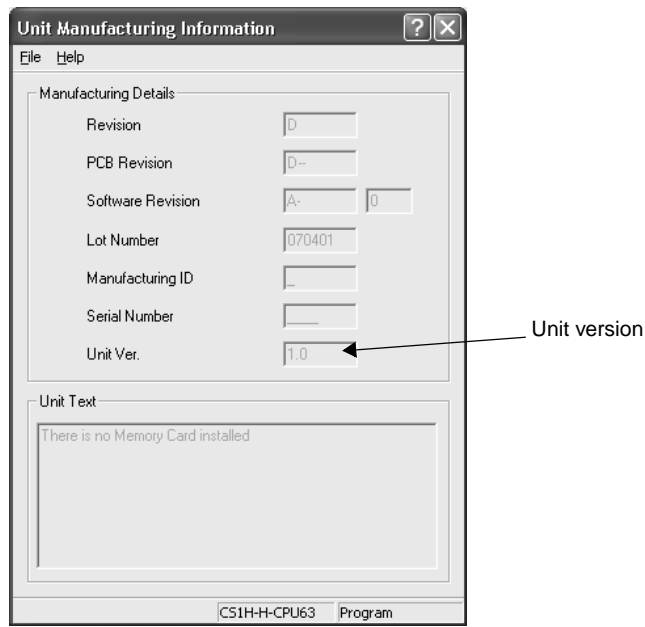

**Note** The unit version will be displayed in the *Unit Manufacturing Information* Dialog Box.

**Using Unit Version Label** The following unit version label is provided with the EtherNet/IP Unit. This label can be attached to the front of the EtherNet/IP Unit to differentiate between EtherNet/IP Units with different unit versions.

**Unit Version Notation** In this manual, the unit version of a EtherNet/IP Unit is given as shown in the following table.

Product nameplate	Notation used in this manual	Special remarks
Ver. 1.0 or later number shown to right of the lot number	Ethernet Unit Ver. 1.0 or later (See note.)	Information without reference to specific Unit Versions applies to all versions of the Unit.

**Note** Some Support Software products call the EtherNet/IP Unit version the “revision.” “Revision” is also sometimes used in this manual.

### Functions That Are Supported for Each Unit Version

	Unit version 2.0 or earlier	Unit version 2.1	
Models	CS1W-EIP21 CJ1W-EIP21 CJ2H-CPU6□-EIP CJ2M-CPU3□	CS1W-EIP21 CJ2H-CPU6□-EIP CJ2M-CPU3□	CJ1W-EIP21
Connection under an NJ-series CPU Unit	Not supported.	Not supported.	Supported. (See note.)

**Note** For details, refer to the *CJ-series EtherNet/IP Units Operation Manual for NJ-series CPU Unit* (Cat. No. W495).

## Applicable CIP Revisions

The following tables list the CIP revisions that are supported by the different unit versions of the EtherNet/IP Unit.

### CS1W-EIP21, CJ1W-EIP21, and CJ2H-CPU□□-EIP

Unit version	CIP revision
Unit version 1.0	Revision 1.01
Unit version 2.0	Revision 2.01 to 2.03
Unit version 2.1	Revision 2.04 or 2.05

### CJ2M-CPU3□

Unit version	CIP revision
Unit version 2.0	Revision 2.01
Unit version 2.1	Revision 2.02 or 2.03

## Unit Versions and Programming Device Versions

The following versions of the CX-Programmer and Network Configuration are required to set EtherNet/IP Units.

### CS1W-EIP21, CJ1W-EIP21, and CJ2H-CPU□□-EIP

Unit version	CX-Programmer		
	Ver. 7.1 or lower	Ver. 8.0	Ver. 8.02 or higher
Unit version 1.0	---	OK <sup>*1</sup>	OK
Unit version 2.0 or later	---	OK	OK <sup>*5</sup>

Unit version	Network Configurator for EtherNet/IP	
	Ver. 3.00 or higher	
Unit version 1.0	OK	
Unit version 2.0 or later	OK	

### CJ2M-CPU3□

Unit version	CX-Programmer		
	Ver. 9.0 or lower	Ver. 9.1	Ver. 9.2 or higher
Unit version 2.0	---	OK	OK
Unit version 2.1	---	OK <sup>*2</sup>	OK <sup>*5</sup>

Unit version	Network Configurator for EtherNet/IP		
	Ver. 3.1 or lower	Ver. 3.20	Ver. 3.21 or higher
Unit version 2.0	---	OK	OK <sup>*3</sup>
Unit version 2.1	---	OK <sup>*4</sup>	OK

\*1: The most recent version of the common module for CX-One version 3.□□ must be installed.

\*2: The most recent version of the common module for CX-One version 4.□□ must be installed.

\*3: The settings cannot be downloaded from the computer to the PLC if more than 20 words of tag data links are set.

\*4: A maximum of 20 words of tag data links can be set.

\*5: For EtherNet/IP Units manufactured in October 2012 or later, you must install CX-Programmer version 9.41 to use the backup functions with the Backup Tool.



# PRECAUTIONS

This section provides general precautions for using the CS/CJ-series EtherNet/IP Units and built-in EtherNet/IP ports.

**The information contained in this section is important for the safe and reliable application of EtherNet/IP Units or built-in EtherNet/IP ports. You must read this section and understand the information contained before attempting to set up or operate an EtherNet/IP Unit or built-in EtherNet/IP port.**

1	Intended Audience .....	xxiv
2	General Precautions .....	xxiv
3	Safety Precautions .....	xxiv
4	Operating Environment Precautions .....	xxvi
5	Application Precautions .....	xxvi
6	Conformance to EC Directives .....	xxviii
6-1	Applicable Directives .....	xxviii
6-2	Concepts .....	xxviii

## 1 Intended Audience

This manual is intended for the following personnel, who must also have knowledge of electrical systems (an electrical engineer or the equivalent).

- Personnel in charge of installing FA systems.
- Personnel in charge of designing FA systems.
- Personnel in charge of managing FA systems and facilities.

## 2 General Precautions

The user must operate the product according to the performance specifications described in the operation manuals.

Before using the product under conditions which are not described in the manual or applying the product to nuclear control systems, railroad systems, aviation systems, vehicles, combustion systems, medical equipment, amusement machines, safety equipment, and other systems, machines, and equipment that may have a serious influence on lives and property if used improperly, consult your OMRON representative.

Make sure that the ratings and performance characteristics of the product are sufficient for the systems, machines, and equipment, and be sure to provide the systems, machines, and equipment with double safety mechanisms.

This manual provides information for programming and operating the Unit. Be sure to read this manual before attempting to use the Unit and keep this manual close at hand for reference during operation.

 **WARNING** It is extremely important that a PLC and all PLC Units be used for the specified purpose and under the specified conditions, especially in applications that can directly or indirectly affect human life. You must consult with your OMRON representative before applying a PLC System to the above-mentioned applications.

## 3 Safety Precautions

 **WARNING** Do not attempt to take any Unit apart while the power is being supplied. Doing so may result in electric shock.

 **WARNING** Do not touch any of the terminals or terminal blocks while the power is being supplied. Doing so may result in electric shock.

 **WARNING** Do not attempt to disassemble, repair, or modify any Units. Any attempt to do so may result in malfunction, fire, or electric shock.





 **WARNING** Provide safety measures in external circuits (i.e., not in the Programmable Controller), including the following items, to ensure safety in the system if an abnormality occurs due to malfunction of the Programmable Controller or another external factor affecting the operation of the Programmable Controller. “Programmable Controller” indicates the CPU Unit and all other Units and is abbreviated “PLC” in this manual.

- Emergency stop circuits, interlock circuits, limit circuits, and similar safety measures must be provided in external control circuits.
- The PLC will turn OFF all outputs when its self-diagnosis function detects any error or when a severe failure alarm (FALS) instruction is executed. As a countermeasure for such errors, external safety measures must be provided to ensure safety in the system.
- The PLC will turn OFF all outputs when its self-diagnosis function detects any error or when a severe failure alarm (FALS) instruction is executed. Unexpected operation, however, may still occur for errors in the I/O control section, errors in I/O memory, and other errors that cannot be detected by the self-diagnosis function. As a countermeasure for all such errors, external safety measures must be provided to ensure safety in the system.
- Provide measures in the computer system and programming to ensure safety in the overall system even if errors or malfunctions occur in data link communications or remote I/O communications.

 **Caution** Execute online editing only after confirming that no adverse effects will be caused by extending the cycle time. Otherwise, the input signals may not be readable.

- Emergency stop circuits, interlock circuits, limit circuits, and similar safety measures must be provided in external control circuits.

 **Caution** Fail-safe measures must be taken by the customer to ensure safety in the event of incorrect, missing, or abnormal signals caused by broken signal lines, momentary power interruptions, or other causes. Serious accidents may result from abnormal operation if proper measures are not provided.

 **Caution** Confirm safety at the destination node before changing or transferring to another node the contents of a program, the PLC Setup, I/O tables, I/O memory, or parameters. Changing or transferring any of these without confirming safety may result in injury.

 **Caution** Tighten the screws on the terminal block of the AC Power Supply Unit to the torque specified in the operation manual. The loose screws may result in burning or malfunction.

## 4 Operating Environment Precautions

 **Caution** Do not operate the control system in the following locations:

- Locations subject to direct sunlight.
- Locations subject to temperatures or humidity outside the range specified in the specifications.
- Locations subject to condensation as the result of severe changes in temperature.
- Locations subject to corrosive or flammable gases.
- Locations subject to dust (especially iron dust) or salts.
- Locations subject to exposure to water, oil, or chemicals.
- Locations subject to shock or vibration.

 **Caution** Take appropriate and sufficient countermeasures when installing systems in the following locations:

- Locations subject to static electricity or other forms of noise.
- Locations subject to strong electromagnetic fields.
- Locations subject to possible exposure to radioactivity.
- Locations close to power supplies.

## 5 Application Precautions

Observe the following precautions when using the EtherNet/IP Unit or built-in EtherNet/IP port.

 **WARNING** Always heed these precautions. Failure to abide by the following precautions could lead to serious or possibly fatal injury.

- Always connect to a ground of 100  $\Omega$  or less when installing the Units. Not connecting to a ground of 100  $\Omega$  or less may result in electric shock.
- Always turn OFF the power supply to the CPU Unit and Slaves before attempting any of the following. Not turning OFF the power supply may result in malfunction or electric shock.
  - Mounting or dismounting Power Supply Units, I/O Units, CPU Units, Memory Packs, or Master Units.
  - Assembling the Units.
  - Setting DIP switches or rotary switches.
  - Connecting cables or wiring the system.
  - Connecting or disconnecting the connectors.

 **Caution** Failure to abide by the following precautions could lead to faulty operation of the EtherNet/IP Unit, built-in EtherNet/IP port, or the system, or could damage the Ethernet Unit. Always heed these precautions.

- Interlock circuits, limit circuits, and similar safety measures in external circuits (i.e., not in the Programmable Controller) must be provided by the customer.

- Always use the power supply voltages specified in the operation manuals. An incorrect voltage may result in malfunction or burning.
- Take appropriate measures to ensure that the specified power with the rated voltage and frequency is supplied. Be particularly careful in places where the power supply is unstable. An incorrect power supply may result in malfunction.
- Install external breakers and take other safety measures against short-circuiting in external wiring. Insufficient safety measures
- Make sure that all the Backplane mounting screws, terminal block screws, and cable connector screws are tightened to the torque specified in the relevant manuals. Incorrect tightening torque may result in malfunction.
- Leave the label attached to the Unit when wiring. Removing the label may result in malfunction if foreign matter enters the Unit.
- Remove the label after the completion of wiring to ensure proper heat dissipation. Leaving the label attached may result in malfunction.
- Use crimp terminals for wiring. Do not connect bare stranded wires directly to terminals. Connection of bare stranded wires may result in burning.
- Observe the following precautions when wiring the communications cable.
  - Separate the communications cables from the power lines or high-tension lines.
  - Do not bend the communications cables past their natural bending radius.
  - Do not pull on the communications cables.
  - Do not place heavy objects on top of the communications cables.
  - Always lay communications cable inside ducts.
  - Use appropriate communications cables.
- Make sure that the terminal blocks, expansion cable connectors, and other items with locking devices are locked in place.
- Wire all connections correctly according to instructions in this manual.
- Double-check all wiring and switch settings before turning ON the power supply. Incorrect wiring may result in burning.
- Mount terminal blocks and connectors only after checking the mounting location carefully.
- Check the user program (ladder program and other programs) and parameters for proper execution before actually running it on the Unit. Not checking the program may result in unexpected operation.
- Confirm that no adverse effect will occur in the system before attempting any of the following. Not doing so may result in an unexpected operation.
  - Changing the operating mode of the PLC.
  - Force-setting/force-resetting any bit in memory.
  - Changing the present value of any word or any set value in memory.
- After replacing a Unit, resume operation only after transferring to the new CPU Unit, Special I/O Unit, or CPU Bus Unit the contents of the DM Area, HR Area, programs, parameters, and other data required for resuming operation. Not doing so may result in an unexpected operation.
- Before touching a Unit, be sure to first touch a grounded metallic object in order to discharge any static build-up. Not doing so may result in malfunction or damage.

- When transporting the Unit, use special packing boxes and protect it from being exposed to excessive vibration or impacts during transportation.
- CPU Bus Units will be restarted when routing tables are transferred from a Programming Device to the CPU Unit. Restarting these Units is required to read and enable the new routing tables. Confirm that the system will not be adversely affected before allowing the CPU Bus Units to be reset.
- When the settings (IP address or tag data link settings) of the EtherNet/IP Unit or built-in EtherNet/IP port are transferred from a Programming Device, all of the destination EtherNet/IP Units or built-in EtherNet/IP ports (nodes) will be reset in order to enable the transferred settings. Transfer settings to the EtherNet/IP Units or built-in EtherNet/IP ports only after verifying that restarting the Units will not cause any problems in the system.
- If a repeater hub is used for EtherNet/IP tag data links (cyclic communications), the network's communications load will increase, data collisions will occur frequently, and stable communications will be impossible. Always use a switching hub when using tag data links in the network.
- Before resetting a CPU Bus Unit or Special I/O Unit, always verify that restart the Unit will not cause any problems in the system.

## 6 Conformance to EC Directives

### 6-1 Applicable Directives

- EMC Directives
- Low Voltage Directive

### 6-2 Concepts

#### EMC Directives

OMRON devices that comply with EC Directives also conform to the related EMC standards so that they can be more easily built into other devices or the overall machine. The actual products have been checked for conformity to EMC standards (see the following note). Whether the products conform to the standards in the system used by the customer, however, must be checked by the customer.

EMC-related performance of the OMRON devices that comply with EC Directives will vary depending on the configuration, wiring, and other conditions of the equipment or control panel on which the OMRON devices are installed. The customer must, therefore, perform the final check to confirm that devices and the overall machine conform to EMC standards.

**Note** Applicable EMS (Electromagnetic Susceptibility) and EMI (Electromagnetic Interference) Standards in the EMC (Electromagnetic Compatibility) standards are as follows:

EtherNet/IP Unit	EMS	EMI
CS1W-EIP21	EN61000-6-2	EN61000-6-4 (Radiated emission: 10-m regulations)
CJ1W-EIP21		

#### Low Voltage Directive

Always ensure that devices operating at voltages of 50 to 1,000 V AC and 75 to 1,500 V DC meet the required safety standards for the PLC (EN61131-2).

# SECTION 1

## Overview of EtherNet/IP

This section introduces the functions and protocols used in EtherNet/IP Unit or built-in EtherNet/IP port communications services.

1-1	EtherNet/IP Unit Features . . . . .	2
1-2	Devices Required for Constructing a Network . . . . .	4
1-3	Support Software Required to Construct a Network. . . . .	4
1-4	Communications Services Overview . . . . .	6
1-5	Network Configurator Overview. . . . .	10
1-5-1	Overview. . . . .	10
1-5-2	Network Configurator Requirements . . . . .	10
1-5-3	Precautions When Using the Network Configurator . . . . .	11

## 1-1 EtherNet/IP Unit Features

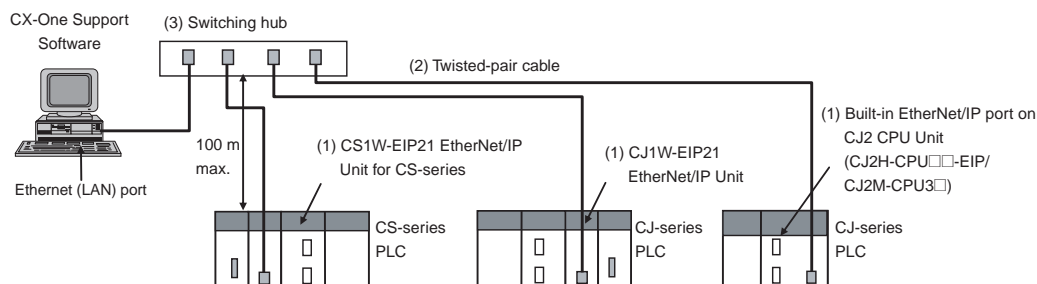

**EtherNet/IP System Configuration Example**

EtherNet/IP is an industrial multi-vendor network that uses Ethernet components. The EtherNet/IP specifications are open standards managed by the ODVA (Open DeviceNet Vendor Association), just like DeviceNet.

EtherNet/IP is not just a network between controllers; it is also used as a field network. Since EtherNet/IP uses standard Ethernet technology, various general-purpose Ethernet devices can be used in the network. The EtherNet/IP Unit and built-in EtherNet/IP port have the following features.

### High-speed, High-capacity Data Exchange through Data Links

The EtherNet/IP protocol supports implicit communications, which allows cyclic communications (called tag data links in this manual) with EtherNet/IP devices. Data can be exchanged at high speed between Controllers and devices, using high-volume tag sets (up to 640 words for the CJ2M-EIP21 and up to 184,832 words for other CPU Units) between PLCs.

### Tag Data Link (Cyclic Communications) Cycle Time

Tag data links (cyclic communications) can operate at the cyclic period specified for each application, regardless of the number of nodes. Data is exchanged over the network at the refresh cycle set for each connection, so the communications refresh cycle will not increase even if the number of nodes is increased, i.e., the synchronicity of the connection's data is preserved.

Since the refresh cycle can be set for each connection, each application can communicate at its ideal refresh cycle. For example, a processes interlocks can be transferred at high speed while the production commands and the status monitor information are transferred at low speed.

**Note** The communications load to the nodes must be within the Units' allowed communications bandwidth.

### Communicating with FINS Messages (FINS/TCP and FINS/UDP)

Data can be exchanged with other OMRON FA devices using SEND, RECV, and CMND instructions from the ladder program, because EtherNet/IP supports OMRON's standard FINS message communications services.

There are two kinds of message services, using UDP/IP and TCP/IP (called FINS/UDP and FINS/TCP), allowing flexible data exchange for different applications.

**Note** There are no particular restrictions when sending FINS messages to OMRON Ethernet Units (CS1W-ETN21 or CJ1W-ETN21) in an Ethernet network.

### Network Connections with Controller Link

Mutual connections of Controller Link and EtherNet/IP are also supported (using the FINS communications service). The Controller Link connection allows a PLC on the Controller Link network to be monitored from a PLC on the EtherNet/IP network. Conversely, data can be exchanged with a PLC on the EtherNet/IP network from a PLC on the Controller Link network.

<b>FTP Server</b>	A built-in FTP server is provided to enable transferring files in the PLC to and from a host computer. This enables transferring large amounts of data from a client without any additional ladder programming.
<b>Automatic PLC Clock Adjustment</b>	<p>The clocks built into PLCs connected to Ethernet can be automatically adjusted to the time of the clock in the SNTP server. If all of the clocks in the system are automatically adjusted to the same time, time stamps can be used to analyze various production histories.</p> <p><b>Note</b> A separate SNTP server is necessary to automatically adjust the PLC clocks.</p>
<b>Manage the Network with an SNMP Manager</b>	<p>Internal status information from the EtherNet/IP Unit or built-in EtherNet/IP port can be passed to network management software that uses an SNMP manager.</p> <p><b>Note</b> A separate SNMP manager is necessary for network management.</p>
<b>Specify Servers with Host Names</b>	<p>DNS client functionality allows you to use host names instead of IP addresses to specify SNTP servers and SNMP managers. This is useful, for example, when server IP addresses change for system revisions because the IP addresses are automatically found when host names are used.</p> <p><b>Note</b></p> <ol style="list-style-type: none"><li>(1) A separate DNS server is necessary to use host names with the DNS client.</li><li>(2) The DNS server is specified directly using its IP address.</li></ol>
<b>Set Classless IP Address with CIDR</b>	A subnet mask can be set to use classless IP addresses, allowing more flexibility in address settings.
<b>Plentiful Troubleshooting Functions</b>	<p>A variety of functions are provided to quickly identify and handle errors.</p> <ul style="list-style-type: none"><li>• Self-diagnosis at power ON</li><li>• PING command to check the connection with another node</li><li>• Error Log functions record the time of occurrence and other error details</li></ul> <p><b>Note</b> The CIP (Common Industrial Protocol) is a shared industrial protocol for the OSI application layer. The CIP is used in networks such as EtherNet/IP, ControlNet, and DeviceNet. Data can be routed easily between networks that are based on the CIP, so a transparent network can be easily configured from the field device level to the host level.</p> <p>The CIP has the following advantages.</p> <ul style="list-style-type: none"><li>• Destination nodes are specified by a relative path, without fixed routing tables.</li><li>• The CIP uses the producer/consumer model. Nodes in the network are arranged on the same level and it is possible to communicate with required devices whenever it is necessary. The consumer node will receive data sent from a producer node when the connection ID in the packet indicates that the node requires the data. Since the producer can send the same data with the same characteristics in a multicast (either multicast or unicast can be selected), the time required for the transfer is fixed and not dependent on the number of consumer nodes.</li></ul>

## 1-2 Devices Required for Constructing a Network

The basic configuration for an EtherNet/IP System consists of one switching hub to which nodes are attached in star configuration using twisted-pair cable.

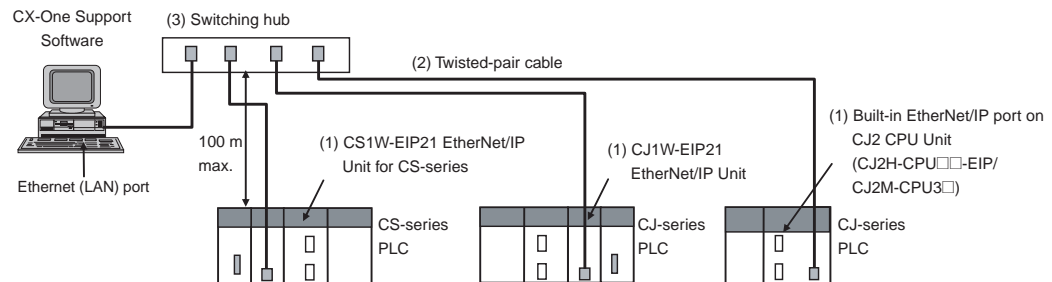

The devices shown in the following table are required to configure a network with CS1W-EIP21 and CJ1W-EIP21 EtherNet/IP Units or the built-in EtherNet/IP port in CJ2H-CPU□□-EIP/CJ2M-CPU3□ CPU Units.

Network device	Contents
(1) CS1W-EIP21 EtherNet/IP Units for CS-series PLCs, CJ1W-EIP21 EtherNet/IP Units for CJ-series PLCs, or built-in EtherNet/IP port in CJ2H-CPU□□-EIP/CJ2M-CPU3□ CPU Units	These are Communications Units or built-in ports that connect a CS-series or CJ-series PLC to an EtherNet/IP network.
(2) Twisted-pair cable	The twisted-pair cable connects EtherNet/IP Units or built-in EtherNet/IP ports to the switching hub, with an RJ45 Modular Connector at each end. Use an STP (shielded twisted-pair) cable of category 5, 5c, or higher.
(3) Switching Hub	This is a relay device that connects multiple nodes in a star-shaped LAN.

### Recommended Switching Hubs

For details on recommended devices for constructing a network, refer to 2-3-1 *Recommended Network Devices*.

**Note** If a repeater hub is used for EtherNet/IP tag data links (cyclic communications), the network's communications load will increase, data collisions will occur frequently, and stable communications will be impossible. Always use a switching hub when using tag data links in the network.

## 1-3 Support Software Required to Construct a Network

This section describes the Support Software that is required to construct an EtherNet/IP network. Make the tag data link settings and Unit setup settings for the EtherNet/IP Unit or built-in EtherNet/IP port. Both of these settings are stored in the EtherNet/IP Unit's non-volatile memory (See note.). Support Software is provided for each, as described below.

**Note** Unlike the Ethernet Units, the EtherNet/IP Unit's TCP/IP settings are not stored in the CPU Unit's CPU Bus Unit System Setup Area. The settings are stored in the EtherNet/IP Unit itself.

### **Unit Setup: CX-Programmer**

The CX-Programmer is used to set basic parameters, such as the local IP address of the EtherNet/IP Unit or built-in EtherNet/IP port and the subnet mask. (The CX-Programmer is included in the CX-One.)  
The CX-Programmer can also be used to check if data I/O is being performed correctly for tag data links.



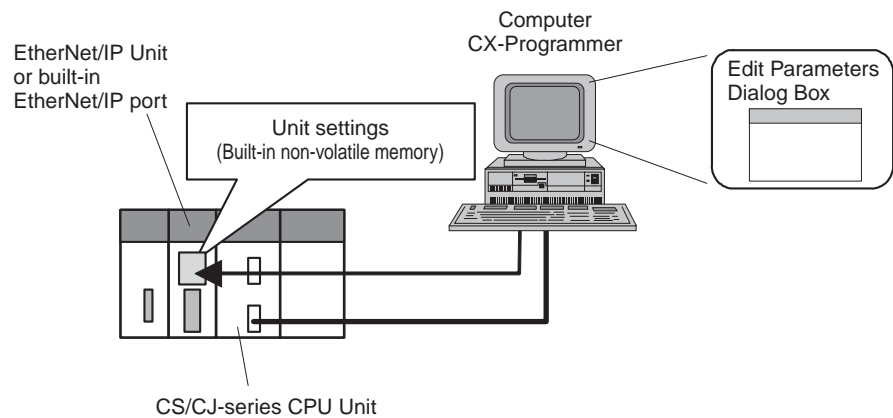

Refer to the *CX-Programmer Operation Manual* (Cat. No. W446) for information on the CX-Programmer.

### Tag Data Link Settings: Network Configurator

The Network Configurator is used to set the tag data links for the EtherNet/IP Unit or built-in EtherNet/IP port. (The Network Configurator is included in CX-One version 3.0 or higher.) The main functions of the Network Configurator are given below.

#### **1) Setting and Monitoring Tag Data Links (Connections)**

The network device configuration and tag data links (connections) can be created and edited. After connecting to the network, the device configuration and tag data link settings can be uploaded and monitored.

#### **2) Multivendor Device Connections**

EDS files can be installed and deleted to enable constructing, setting, and managing networks that contain EtherNet/IP devices from other companies. The IP addresses of EtherNet/IP devices can also be changed.

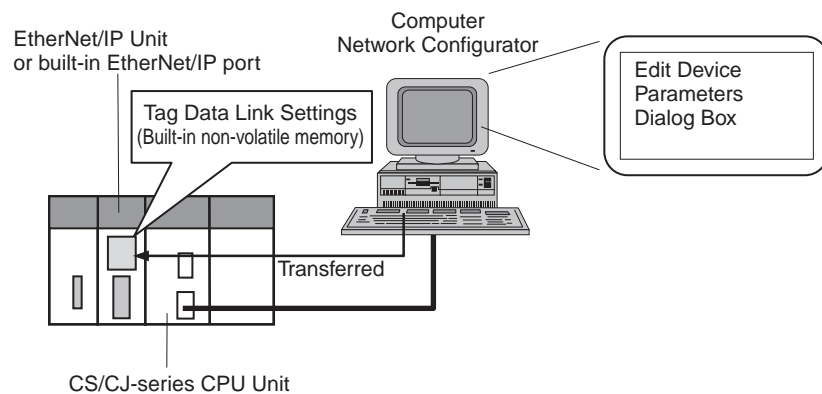

For details on the Network Configurator, refer to *SECTION 6 Tag Data Link Functions*.

### Routing Table Settings: CX-Integrator

Proprietary OMRON FINS network system can be constructed from OMRON Communications Units. When FINS services are used, the CX-Integrator allows you to set routing tables to define transmission paths. (The CX-Integrator is included in the CX-One.) If FINS services are not used, then routing tables are not required.

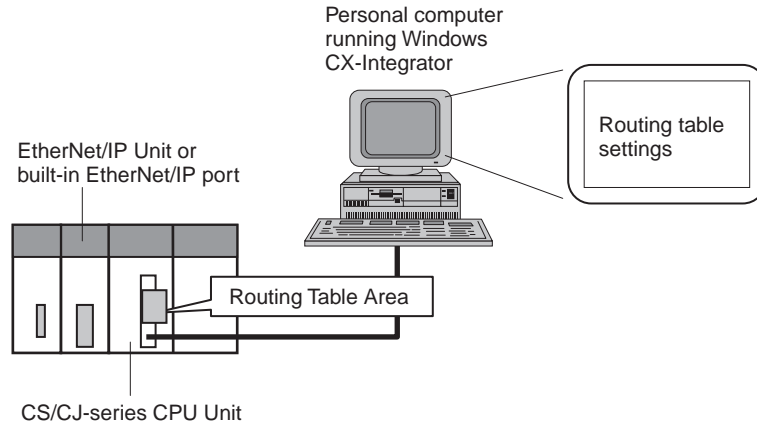

Refer to the *CX-Integrator Operation Manual* (Cat. No. W464) for information on the CX-Integrator.

## 1-4 Communications Services Overview

The following communications services are supported.

### CIP (Common Industrial Protocol) Communications Services

#### **1) Tag Data Links (Cyclic Communications)**

A program is not required to perform cyclic data exchanges with other devices in the EtherNet/IP network.

Normally, the tag data links in an EtherNet/IP Unit or built-in EtherNet/IP port are started by grouping the tags created with the Network Configurator into a tag set, and establishing a connection with the target device using that group of tags. One connection is used per group (tag set). Up to 32 connections for the CJ2M-EIP21 and up to 256 connections for other CPU Units) can be registered.

The following table gives the tag and tag set specifications.

Tags		Tag sets	
CS1W-EIP21 CJ1W-EIP21 CJ2H-CPU□□-EIP	CJ2M-CPU3□	CS1W-EIP21 CJ1W-EIP21 CJ2H-CPU□□-EIP	CJ2M-CPU3□
Total size of all tags ≤ 184,832 words	Total size of all tags ≤ 640 words	Maximum size of 1 tag set ≤ 722 words (The maximum size is 721 words when the tag set includes the PLC status.)	Maximum size of 1 tag set ≤ 640 words <sup>*1</sup> (The maximum size is 639 words when the tag set includes the PLC status.) <sup>*2</sup>
Maximum size of 1 tag ≤ 722 words (The maximum size is 721 words when the tag set includes the PLC status.)	Maximum size of 1 tag ≤ 640 words <sup>*1</sup> (The maximum size is 639 words when the tag set includes the PLC status.) <sup>*2</sup>	Number of tags per tag set ≤ 8 (7 tags/tag set when the tag set includes the PLC status) <b>Note</b> Input and output variables cannot be combined.	
Number of registrable tags ≤ 256	Number of registrable tags ≤ 32	Number of registrable tag sets ≤ 256	Number of registrable tag sets ≤ 32

<sup>\*1</sup> Unit version 2.0: 20 words maximum.

<sup>\*2</sup> Unit version 2.0: 19 words maximum.

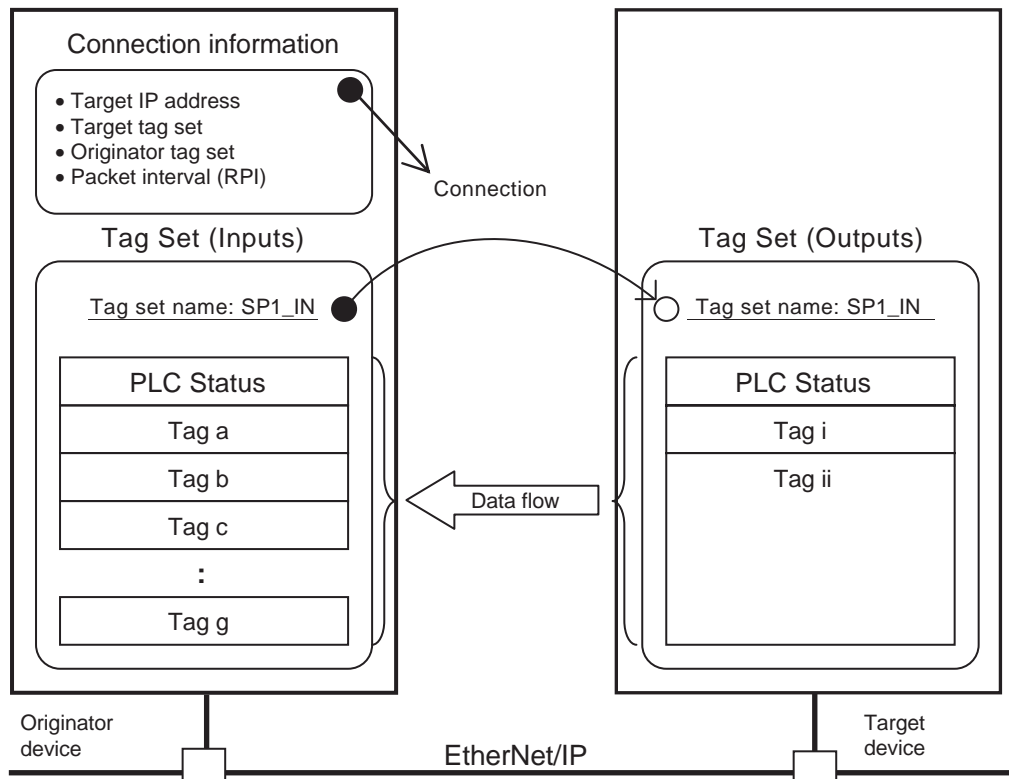

- Note**
- (1) In this example, a connection is established with the originator's tag list containing tags a to g (inputs), which are grouped in a tag set called SP1\_IN, and the target's tag list containing tags i and ii (outputs), which are grouped in a tag set called SP1\_OUT.
  - (2) The specifications for using tag data links with the CJ2M built-in EtherNet/IP port on a CJ2M-CPU3□ CPU Unit are different from the specifications for EtherNet/IP Units (CJ1W-EIP21 or CS1W-EIP21) and the CJ2H built-in EtherNet/IP port on a CJ2H-CPU□□-EIP CPU Unit. Make sure you are using the correct specifications for the application. Refer to 2-1-3 *Communications Specifications* for the communications specifications.

**2) Message Communications (Unconnected Message Service)**

User-specified CIP commands can be sent to devices on the EtherNet/IP network. CIP commands, such as those for reading and writing data, can be sent and their responses received by executing the CMND instruction from the CS/CJ-series CPU Unit's user program (without using a connection).

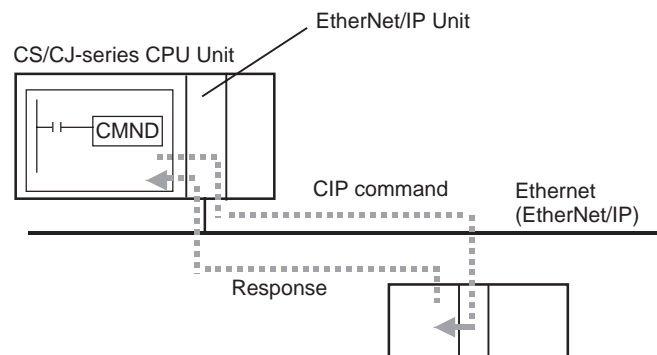

CIP messages (CIP commands and responses) can also be transferred to another CIP-based network via the EtherNet/IP Unit or built-in EtherNet/IP port using the CIP routing function for message communications.

In the CS/CJ Series, CIP routing is possible only through two EtherNet/IP Units or built-in EtherNet/IP port.

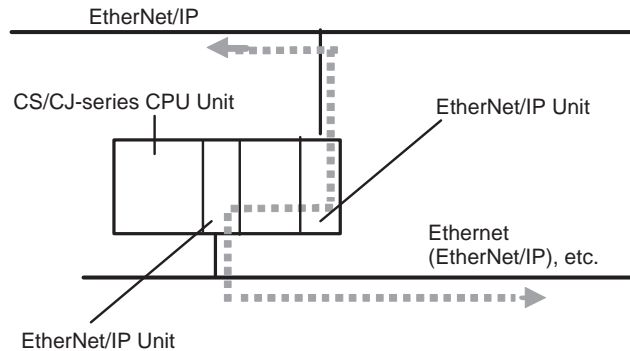

**FINS**  
**Communications**  
**Service**

FINS commands can be sent to or received from other PLCs or computers on the same Ethernet network by executing SEND(090), RECV(098), or CMND(490) instructions in the ladder diagram program. This enables various control operations such as the reading and writing of I/O memory between PLCs, mode changes, and file memory operations.

**Note** There are no particular restrictions when sending FINS messages to OMRON Ethernet Units (CS1W-ETN21 or CJ1W-ETN21) in an Ethernet network.

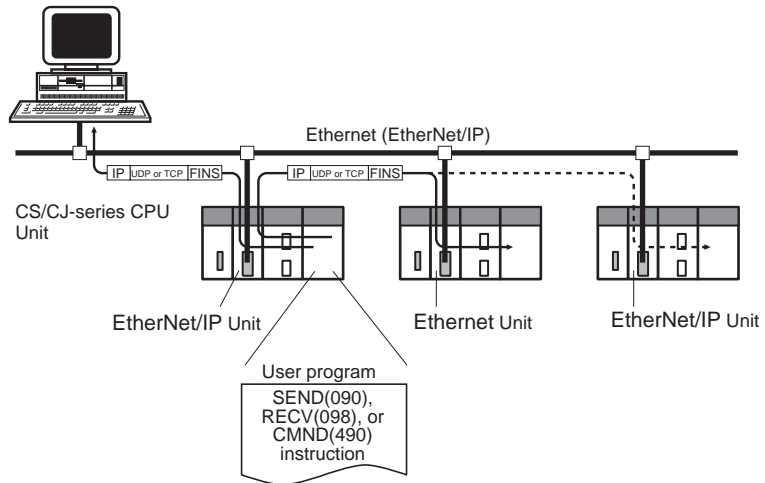

Various control operations (such as the reading and writing of I/O memory between PLCs, mode changes, and file memory operations) can be executed from the host computer by sending the corresponding FINS command with a UDP/IP or TCP/IP header attached.

For example, it is possible to connect online via Ethernet from FINS communications applications such as the CX-Programmer, and to perform remote programming and monitoring. (See note.)

**Note** Use CX-Programmer version 4.0 to use TCP/IP. For lower versions of CX-Programmer, FinsGateway Version 2003 or higher is required to use TCP/IP.

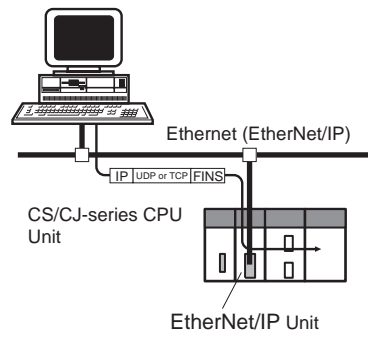

The FINS gateway function enables access to PLCs on not only the same Ethernet network but on various other networks, including SYSMAC LINK and Controller Link.

## 1-5 Network Configurator Overview

### 1-5-1 Overview

Network Configurator version 3.0 or higher is a software package designed for building, setting, and controlling a multi-vendor EtherNet/IP Network using OMRON's EtherNet/IP. It is included in CX-One version 4.0 or higher. Network Configurator version 3.20 is necessary to use the built-in EtherNet/IP port on a CJ2M-CPU3□ CPU Unit. Network Configurator version 3.20 is included with CX-One version 4.0 or higher. The Network Configurator provides the following functions for building, setting, and controlling EtherNet/IP.

#### Network Control

The Network configuration can be created and edited regardless of whether the Network Configurator is online or offline. The Network configuration can be read from a file or the network.

#### Hardware (EDS File) Control

EDS files used by the Network Configurator can be installed and deleted.

### 1-5-2 Network Configurator Requirements

Item		Specification	
Operating environment		Refer to the <i>CX-One Setup Manual (W463)</i> . CXONE-AL□□C-V4/CXONE-AL□□D-V4	
Network connection method		<b>CS1/CJ1</b>	<b>CJ2</b>
	Serial interface	CPU Unit's Peripheral or RS-232C port	CPU Unit's USB or RS-232C port
	Ethernet interface	EtherNet/IP Unit's Ethernet port	CPU Unit's Ethernet port EtherNet/IP Unit's Ethernet port
Location on Network		A single node address is used (only when directly connected to EtherNet/IP).	
Number of Units that can be connected to Network		A single Network Configurator per network (More than one Configurator cannot be used in the same system.)	
Main functions	Network control functions	<ul style="list-style-type: none"> <li>• The network configuration can be created and edited regardless of whether the Network Configurator is online or offline.</li> <li>• The network configuration can be read from a file or the network.</li> </ul>	
	Hardware control functions	The EDS files used by the Network Configurator can be installed and deleted.	
Supported file formats		Configurator network configuration files (*.nvf) Configuration files (*.ncf) created using the Network Configurator for EtherNet/IP (version 2) can be imported by selecting <b>External Data - Import</b> from the File Menu.	

### **1-5-3 Precautions When Using the Network Configurator**

Only an OMRON EtherNet/IP Unit can be set as the originator for a connection using the Network Configurator.

- The Network Configurator can be connected to the EtherNet/IP network through the following ports:
  - CS1/CJ1-series CPU Unit's serial port (peripheral or RS-232C) or Ethernet port on EtherNet/IP Unit
  - CJ2-series CPU Unit's serial port (USB or RS-232C), Ethernet port on EtherNet/IP Unit or built-in EtherNet/IP port
- The Network Configurator can be connected directly to the EtherNet/IP network from the computer's Ethernet port. When connecting directly to the EtherNet/IP network, an Ethernet port must be set up in the computer in advance. In this case, the Network Configurator will be connected to the EtherNet/IP network as a single node. If there isn't an unused node address available, the Network Configurator can't be connected directly to the EtherNet/IP network.





# SECTION 2

## Unit Specifications

This section provides the specifications of EtherNet/IP Units and introduces recommended network configuration devices.

- 2-1 EtherNet/IP Unit and Built-in EtherNet/IP Port Specifications . . . . . 14
  - 2-1-1 General Specifications . . . . . 14
  - 2-1-2 Unit Specifications . . . . . 14
  - 2-1-3 Communications Specifications . . . . . 17
  - 2-1-4 Dimensions . . . . . 19
  - 2-1-5 Software Configuration. . . . . 21
- 2-2 Nomenclature and Functions . . . . . 22
  - 2-2-1 Nomenclature and Functions . . . . . 22
  - 2-2-2 Switch Settings . . . . . 27
- 2-3 Selecting the Network Devices . . . . . 29
  - 2-3-1 Recommended Network Devices . . . . . 29
  - 2-3-2 Network Devices Manufactured by OMRON . . . . . 29
  - 2-3-3 Switching Hub Types . . . . . 29
  - 2-3-4 Switching Hub Functions . . . . . 30
  - 2-3-5 Precautions When Selecting a Switching Hub . . . . . 30

## 2-1 EtherNet/IP Unit and Built-in EtherNet/IP Port Specifications

### 2-1-1 General Specifications

The general specifications conform to those of the CS-series and CJ-series PLCs.

### 2-1-2 Unit Specifications

#### CS-series EtherNet/IP Units

Item		Specifications
Model number		CS1W-EIP21
Type		100Base-TX (See note.)
Applicable PLCs		CS-series PLCs
Unit classification		CS-series CPU Bus Unit
Mounting location		CPU Rack or Expansion Rack
Number of Units that can be mounted		8 max. (including Expansion Racks)
CPU Unit words used	Allocated CIO Area words (CPU Bus Unit words)	25 words/Unit (one unit number's words) These words contain control bits and flags, the target node PLC's operating and error information, Unit status, communications status, registered/normal target node information, and FINS/TCP connection status.
	Allocated DM Area words (CPU Bus Unit words)	100 words/Unit (one unit number's words) These words contain the IP address display/setting area
	User-set area	Any usable data area words Target node PLC's operating and error information, and registered/normal target node information
	CPU Bus Unit System Setup	Not used.
Non-volatile memory within EtherNet/IP Unit (See note.)		The following settings are stored in the EtherNet/IP Unit's non-volatile memory. <b>Note</b> Unlike the regular Ethernet Units, the CPU Bus Unit Setup Area in the CPU Unit is not used for these settings. 1. Unit setup (communications settings for the EtherNet/IP Unit, such as the IP address, DNS server settings, host name, baud rate, FINS/UDP settings, and FINS/TCP settings) 2. Tag data link settings (device parameters)
Transfer specifications	Media access method	CSMA/CD
	Modulation method	Baseband
	Transmission paths	Star form
	Baud rate	100 Mbit/s (100Base-TX)
	Transmission media	Shielded twisted-pair (STP) cable Categories: 100 $\Omega$ at 5, 5e
	Transmission distance	100 m (distance between hub and node)
Number of cascade connections		There is no limitation when a switching hub is used.
Current consumption (Unit)		410 mA max. at 5 V DC
Weight		171 g max.
Dimensions		35 × 130 × 101 mm (W × H × D)
Other general specifications		Other specifications conform to the general specifications of the CS-series

**Note** If tag data links are being used, use 100Base-TX. Otherwise, 10Base-T can be used, but this is not recommended.

**CJ-series EtherNet/IP Unit**

Item		Specifications
Model number		CJ1W-EIP21
Type		100Base-TX (See note.)
Applicable PLCs		CJ-series PLCs
Unit classification		CJ-series CPU Bus Unit
Mounting location		CPU Rack or Expansion Rack
Number of Units that can be mounted		8 max. (including Expansion Racks) <b>Note</b> Up to seven EtherNet/IP Units can be connected to a CJ2H-CPU□□-EIP CPU Unit. A maximum of two EtherNet/IP Units can be connected to a CJ2M CPU Unit (regardless of whether the CPU Unit has a built-in port).
CPU Unit words used	Allocated CIO Area words (CPU Bus Unit words)	25 words/Unit (one unit number's words) These words contain control bits and flags, the target node PLC's operating and error information, Unit status, communications status, registered/normal target node information, and FINS/TCP connection status.
	Allocated DM Area words (CPU Bus Unit words)	100 words/Unit (one unit number's words) These words contain the IP address display/setting area.
	User-set area	Any usable data area words Target node PLC's operating and error information, and registered/normal target node information
	CPU Bus Unit System Setup	Not used.
Non-volatile memory within EtherNet/IP Unit (See note.)		The following settings are stored in the EtherNet/IP Unit's non-volatile memory. <b>Note</b> Unlike the regular Ethernet Units, the CPU Bus Unit Setup Area in the CPU Unit is not used for these settings. 1. Unit Setup (communications settings for the EtherNet/IP Unit, such as the IP address, DNS server settings, host name, baud rate, FINS/UDP settings, and FINS/TCP settings) 2. Tag data link settings (device parameters)
Transfer specifications	Media access method	CSMA/CD
	Modulation method	Baseband
	Transmission paths	Star form
	Baud rate	100 Mbit/s (100Base-TX)
	Transmission media	Shielded twisted-pair (STP) cable Categories: 100 Ω at 5, 5e
	Transmission distance	100 m (distance between hub and node)
	Number of cascade connections	There is no limitation when a switching hub is used.
Current consumption (Unit)		410 mA max. at 5 V DC
Weight		94 g max.
Dimensions		31 × 90 × 65 mm (W × H × D)
Other general specifications		Other specifications conform to the general specifications of the CJ-series.

**Note** If tag data links are being used, use 100Base-TX. Otherwise, 10Base-T can be used, but this is not recommended.

**CJ2 CPU Built-in EtherNet/IP Port**

Item		Specifications
Model number		CJ2H-CPU□□-EIP   CJ2M-CPU3□
Type		100Base-TX (See note.)
Unit classification		CJ2 CPU Unit built-in port (CJ2 CPU Bus Unit)
CPU Unit words used	Allocated CIO Area words (CPU Bus Unit words)	25 words/Unit (one unit number's words) These words contain control bits and flags, the target node PLC's operating and error information, Unit status, communications status, registered/normal target node information, and FINS/TCP connection status.
	Allocated DM Area words (CPU Bus Unit words)	100 words/Unit (one unit number's words) These words contain the IP address display/setting area.
	User-set area	Any usable data area words Target node PLC's operating and error information, and registered/normal target node information
	CPU Bus Unit System Setup	Not used.
Non-volatile memory for the CJ2 built-in EtherNet/IP port		The following settings are stored in the non-volatile memory for the built-in EtherNet/IP port. <b>Note</b> Unlike the regular Ethernet Units, the CPU Bus Unit Setup Area in the CPU Unit is not used for these settings. 1. Unit Setup (communications settings for the built-in EtherNet/IP port, such as the IP address, DNS server settings, host name, baud rate, FINS/UDP settings, and FINS/TCP settings) 2. Tag data link settings (device parameters)
Transfer specifications	Media access method	CSMA/CD
	Modulation method	Baseband
	Transmission paths	Star form
	Baud rate	100 Mbit/s (100Base-TX)
	Transmission media	Shielded twisted-pair (STP) cable Categories: 100 Ω at 5, 5e
	Transmission distance	100 m (distance between hub and node)
	Number of cascade connections	There is no limitation when a switching hub is used.
Current consumption (Unit)		For CJ2 CPU Units, refer to the <i>CJ2 CPU Hardware Operation Manual (W472)</i> .
Weight		
Dimensions		
Other general specifications		Other specifications conform to the general specifications of the CJ2 or built-in EtherNet/IP port CJ2 CPU Unit.

**Note** If tag data links are being used, use 100Base-TX. Otherwise, 10Base-T can be used, but this is not recommended.

### 2-1-3 Communications Specifications

Item		CS1/CJ1	CJ2H	CJ2M	
CIP service	Tag data links (Cyclic communications)	Number of connections	256		
		Packet interval (refresh cycle)	0.5 to 10,000 ms (in 0.5-ms units) Can be set independently for each connection. (Data is refreshed over the network at the preset interval and does not depend on the number of nodes.)		
		Allowed communications bandwidth per Unit	6000 pps (See note 1.) <b>Note</b> Including the heartbeat.		
		Number of tags that can be registered	256		
		Tag types	CIO Area, DM Area, EM Area, Holding Area, Work Area, and network symbols (See note 8.)		
		Number of tags per connection (= 1 tag set)	8 (7 tags when the tag set contains the PLC status)		
		Maximum link data size per node (total size of all tags)	184,832 words		640 words (See note 9.)
		Maximum data size per connection	252 words or 722 words (See note 2.) <b>Note</b> Data synchronicity is maintained within each connection.		640 words (See note 9.) <b>Note</b> Data synchronicity is maintained within each connection.
		Number of registrable tag sets	256 (1 connection = 1 tag set)		32 (1 connection = 1 tag set)
		Maximum size of 1 tag set	722 words (The PLC status uses 1 word when the tag set contains the PLC status.)		20 words (The PLC status uses 1 word when the tag set contains the PLC status.)
		Maximum number of tags that can be refreshed per CPU Unit cycle (See note 3.)	Output/Transmission (CPU → EtherNet/IP): 19 Input/Reception (EtherNet/IP → CPU): 20 (See note 4.)	Output/Transmission (CPU → EtherNet/IP): 256 Input/Reception (EtherNet/IP → CPU): 256	Output/Transmission (CPU → EtherNet/IP): 32 Input/Reception (EtherNet/IP → CPU): 32
		Data that can be refreshed per CPU Unit cycle (See note 3.)	Output/Transmission (CPU → EtherNet/IP): 7,405 words Input/Reception (EtherNet/IP → CPU): 7,405 words	Output/Transmission (CPU → EtherNet/IP): 6,432 words Input/Reception (EtherNet/IP → CPU): 6,432 words	Output/Transmission (CPU → EtherNet/IP): 640 words Input/Reception (EtherNet/IP → CPU): 640 words
		Changing tag data link parameters during operation	Supported (See note 5.)		
		Multicast packet filter function (See note 6.)	Supported		

Item		CS1/CJ1	CJ2H	CJ2M
CIP service	Explicit messaging	Class 3 (connected)	Number of connections: 128	
		UCMM (unconnected)	Number of clients that can communicate at one time: 32 max. Number of servers that can communicate at one time: 32 max.	Number of clients that can communicate at one time: 16 max. Number of servers that can communicate at one time: 16 max.
	CIP routing	CS1W-EIP21 CJ1W-EIP21 CJ2H-CPU□□-EIP CJ2M-CPU3□		
FINS service (See note 7.)		FINS/UDP	Supported	
		FINS/TCP	16 connections max.	
SNMP		Agent	SNMPv1, SNMPv2c	
		MIB	MIB-II	
EtherNet/IP conformance test		Conforms to A5		
Ethernet interface		10BASE-T or 100BASE-TX Auto Negotiation or fixed settings		

- Note**
- (1) In this case, pps means “packets per second” and indicates the number of packets that can be processed in one second.
  - (2) To use 505 to 1,444 bytes as the data size, the system must support the Large Forward Open standard (an optional CIP specification). The SYS-MAC CS/CJ-series Units support this standard, but before connecting to nodes of other companies, confirm that those devices also support it.
  - (3) If the maximum data size is exceeded, the data refreshing with the CPU Unit will extend over two or more cycles.
  - (4) If status layout is selected in the user settings, the maximum number of tags that can be received is 19 tags.
  - (5) If parameters are changed in the EtherNet/IP Unit, however, the EtherNet/IP Unit will be restarted. When other nodes are communicating with the affected node, the communications will temporarily time out and automatically recover later.
  - (6) Because the EtherNet/IP Unit is equipped with an IGMP client (version 2), unnecessary multicast packets can be filtered by using a switching hub that supports IGMP snooping.
  - (7) The EtherNet/IP Unit uses the TCP/UDP port numbers shown in the following table.

Service	Protocol	Port number	Remarks
Tag data links	UDP	2222	Fixed value
Class 3, UCMM	TCP/UDP	44818	
DNS	UDP	53	
FINS/UDP service	UDP	9600	Port numbers in the Unit Setup can be changed with the CX-Programmer.
FINS/TCP service	TCP	9600	
FTP	TCP	20, 21	
SNTP	UDP	123	
SNMP	UDP	161	
SNMP trap	UDP	162	

(8) Network symbols are supported only for the CJ2H-CPU6□-EIP and CJ2M-CPU3□ CPU Units.

(9) Unit version 2.0: 20 words maximum.

**Note** The communications specifications of EtherNet/IP ports on CJ2M CPU Units depend on the unit version. Check the differences in specifications between unit versions carefully before using a port.

### 2-1-4 Dimensions

#### CS1W-EIP21

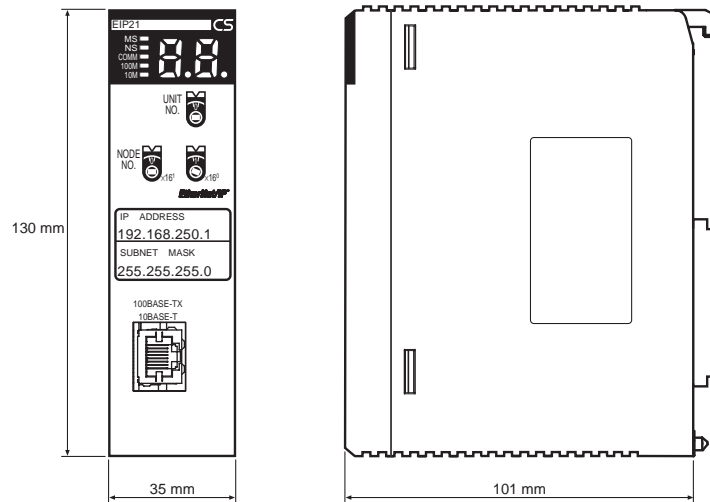

#### CJ1W-EIP21

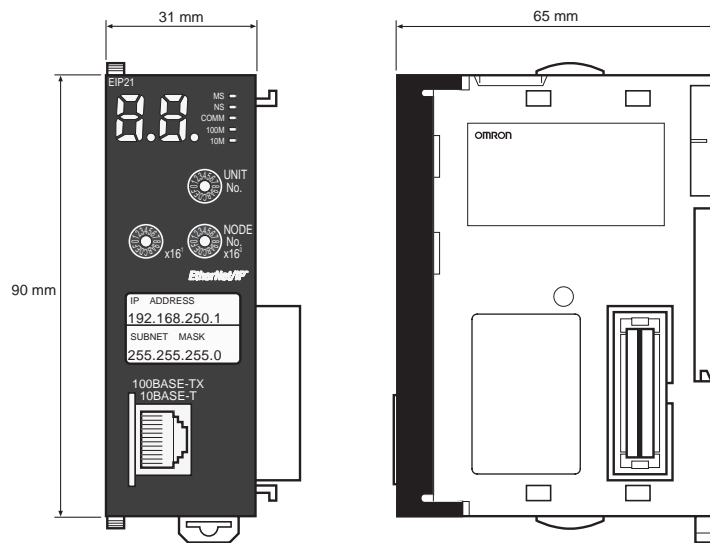

CJ2H-CPU□□-EIP

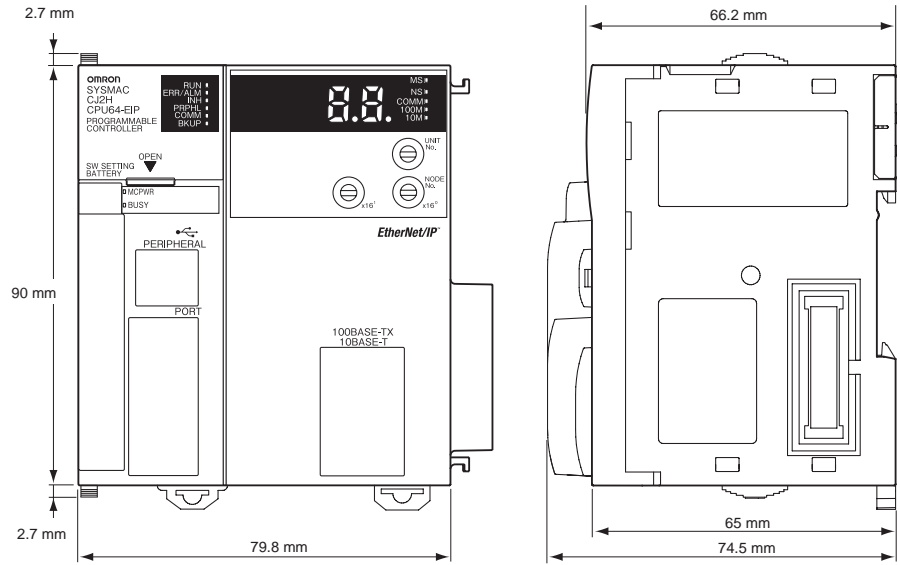

CJ2M-CPU3□

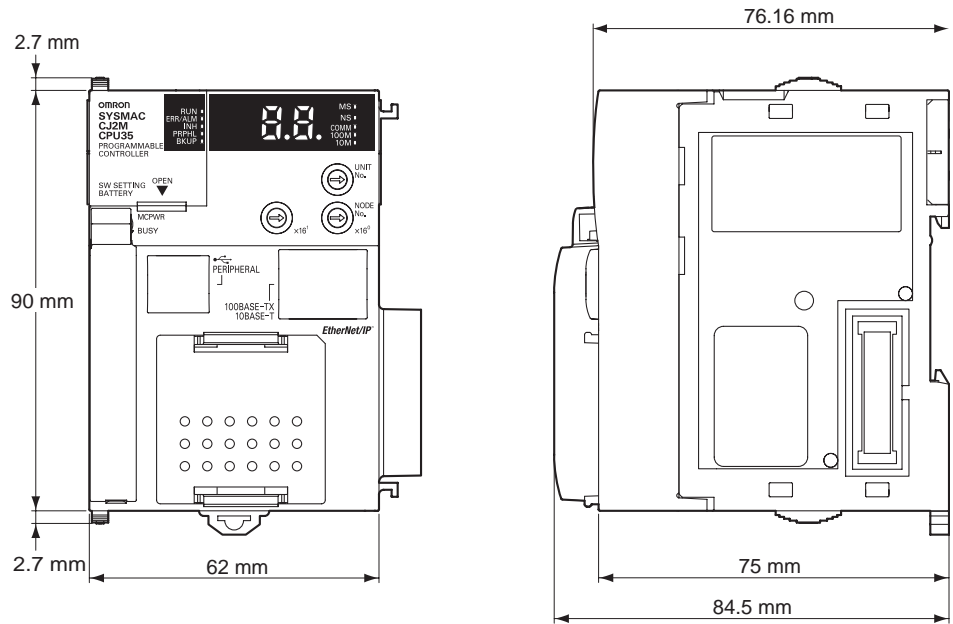



### 2-1-5 Software Configuration

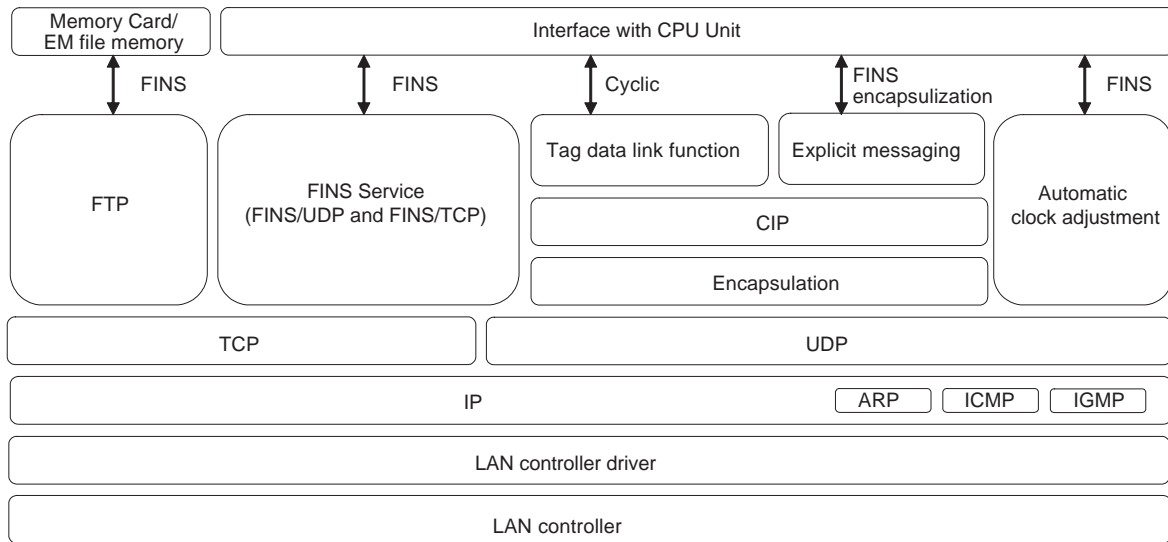

## 2-2 Nomenclature and Functions

### 2-2-1 Nomenclature and Functions

#### CS1W-EIP21

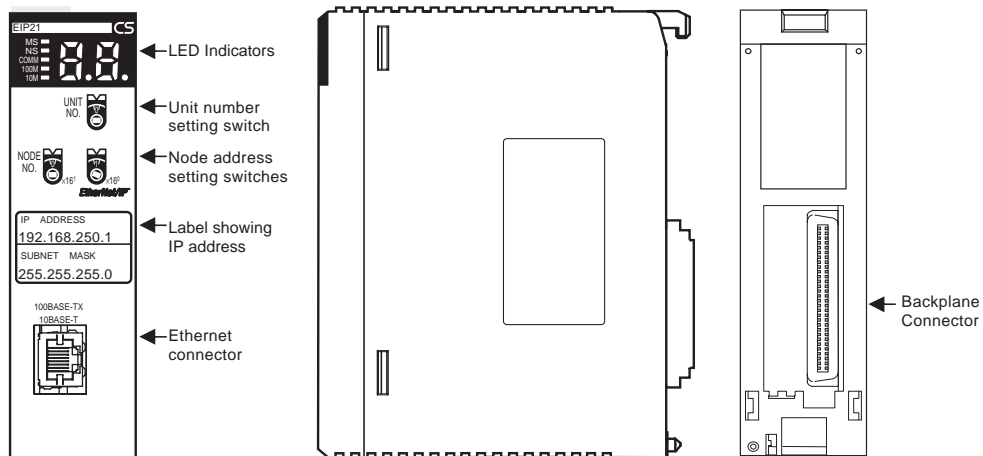

#### CJ1W-EIP21

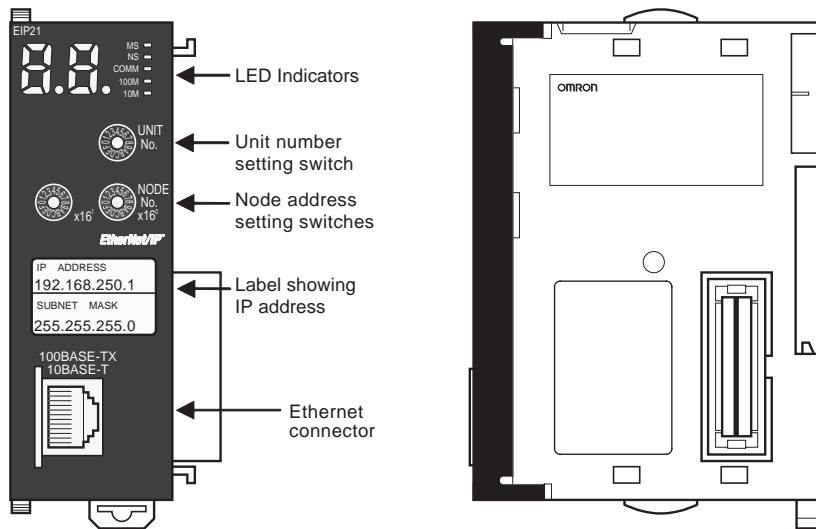

**Built-in EtherNet/IP Port in CJ2H-CPU□□-EIP**

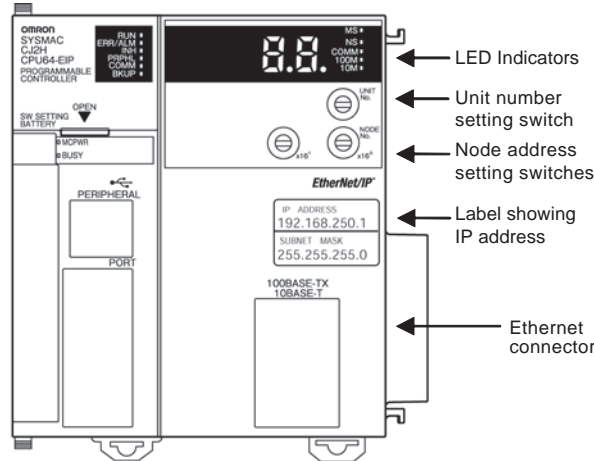

**Built-in EtherNet/IP Port in CJ2M-CPU3□**

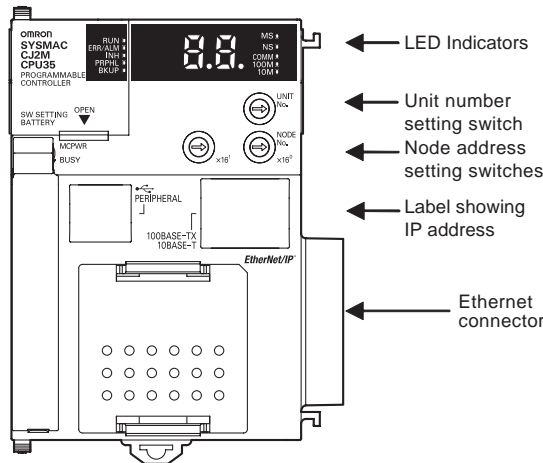

**Ethernet Address Notation**

A specific Ethernet address is allocated to all devices connected to the Ethernet network. The EtherNet/IP Unit's address is listed in 12-digit hexadecimal on the right side of the Unit.

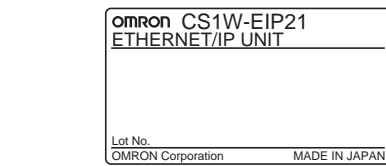

□□□□□□□□□□□□  
Ethernet Address

Ethernet address (12 digits)

**Note**

- (1) The Ethernet Address can also be checked with the CONTROLLER DATA READ command. For details, refer to *Appendix E FINS Commands Addressed to EtherNet/IP Units or Built-in EtherNet/IP Ports*.
- (2) An IP address label is included with the EtherNet/IP Unit, so the user can record the user-set IP address and subnet mask on the label, and affix the label to the front of the Unit. When this label is affixed to the front of the Unit, it is easy to confirm the Unit's IP address and subnet mask.

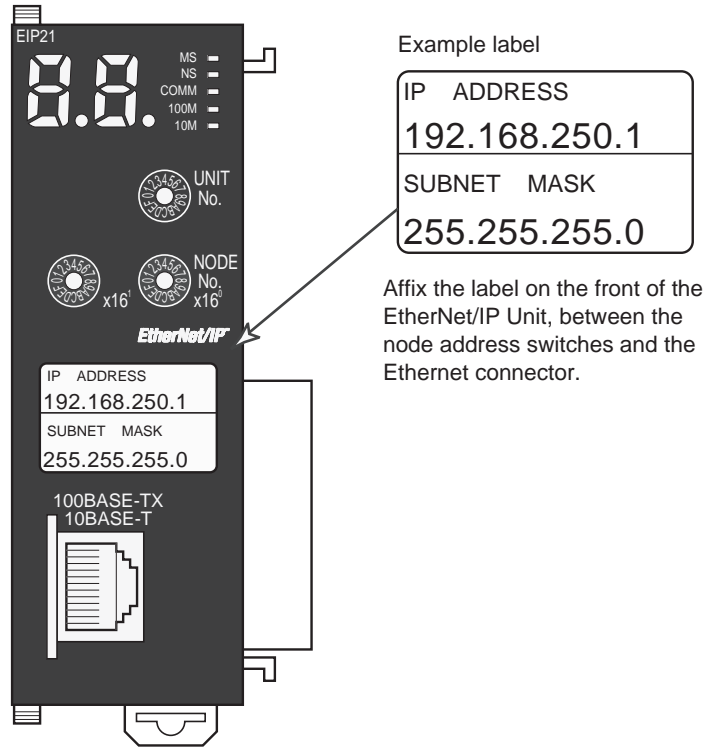

Example label

IP ADDRESS  
192.168.250.1  
SUBNET MASK  
255.255.255.0

Affix the label on the front of the EtherNet/IP Unit, between the node address switches and the Ethernet connector.

**Indicators**

A EtherNet/IP Units or built-in EtherNet/IP port is equipped with the following indicators that indicate the operating status of the node itself and the overall network.

CS1W-EIP21

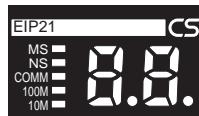

CJ1W-EIP21, CJ2H-CPU□□-EIP, and CJ2M-CPU3□



**Status Indicators: MS, NS, COMM, 100M, and 10M**

The MS (Module Status) indicator indicates the status of the node itself and the NS (Network Status) indicator indicates the status of the network.

The COMM, 100M, and 10M indicators indicate the status of Ethernet communications.

The MS and NS indicators can be green or red. The COMM, 100M, and 10M indicators are yellow. These indicators can be lit, flashing, or not lit. The following table shows the meaning of these indicator conditions.

Refer to *SECTION 14 Troubleshooting and Error Processing* for details on using these indicators for troubleshooting.

Indicator	Name	Color	LED status	Indicated operating status
MS	Module Status	Red	Lit	Fatal error
			Flashing	Recoverable error
		Green	Lit	Normal
			---	Not lit
NS	Network Status	Red	Lit	Fatal error
			Flashing	Recoverable error
		Green	Lit	Tag data link and message connections established
			Flashing	Tag data link and message connections not established
---	Not lit	Offline or power supply OFF		
COMM	Communication	Yellow	Lit	Transferring data
			Not lit	Not transferring data
100M	100 Mbps	Yellow	Lit	100BASE-TX link established
			Not lit	100BASE-TX link not established
10M	10 Mbps	Yellow	Lit	10BASE-TX link established
			Not lit	10BASE-TX link not established

**Seven-segment Display**

When the power is turned ON (or the Unit is restarted), all of the segments will flash twice, the IP address set in the EtherNet/IP Unit or built-in EtherNet/IP port will be displayed on the 7-segment display just once, from right to left. Afterwards, the rightmost 8 bits of the IP address is displayed in hexadecimal during normal operation.

**Example 1: Displaying IP Address 192.168.250.10**

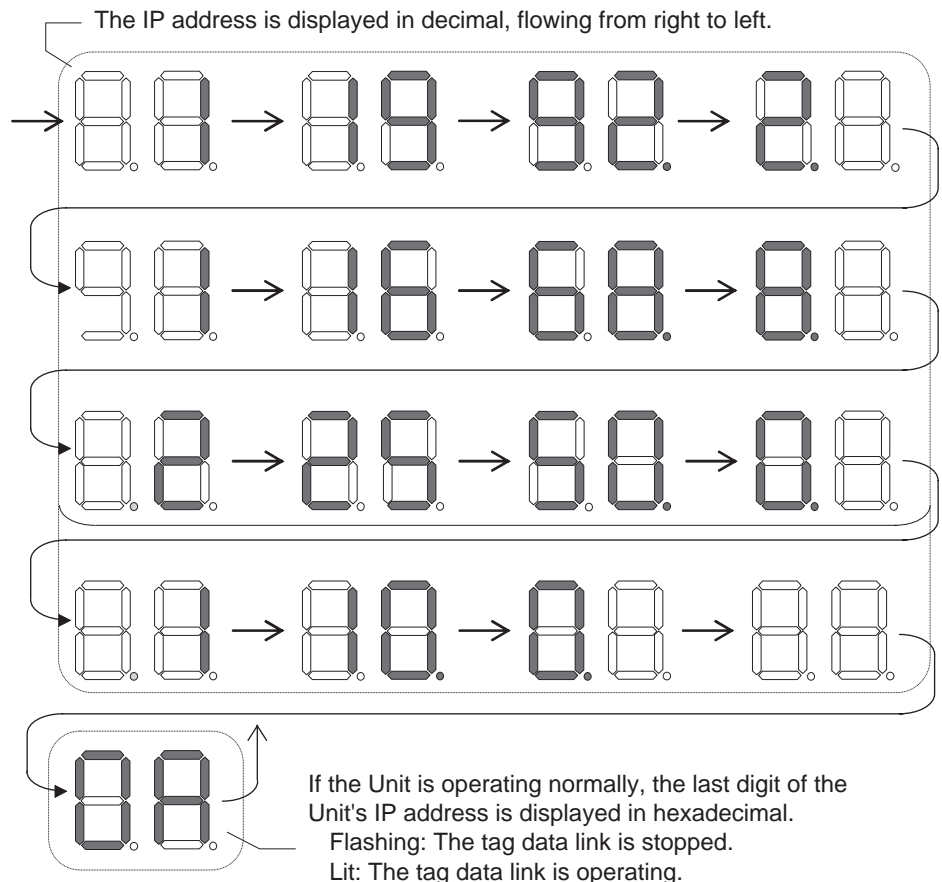

If an error occurs, the error code will be displayed alternately with the right-most byte of the affected device's IP address. For details on error codes, refer to SECTION 14 Troubleshooting and Error Processing.

**Displaying Multiple Error Sources**

- A d6 error (failed to establish connection) occurred with IP address 192.168.250.8.
- A d6 error (failed to establish connection) occurred with IP address 192.168.250.9.
- A d5 error (verification error, target nonexistent) occurred with IP address 192.168.250.64.
- A C6 error (multiple switches ON) and EA error (EtherNet/IP expansion setting error) occurred at the local EtherNet/IP Unit or built-in EtherNet/IP port, IP address 192.168.250.10.

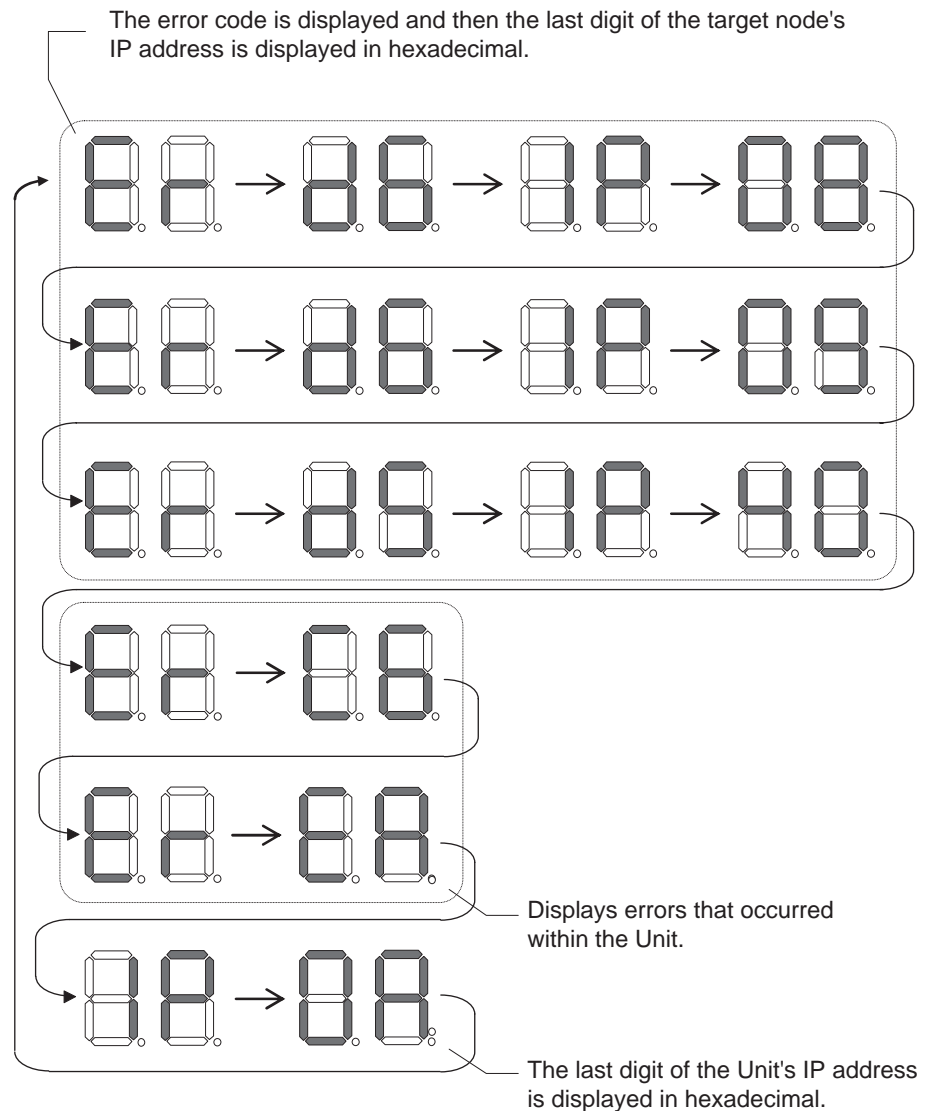

- There is no particular priority to the order in which the errors are displayed. All of the errors are displayed repeatedly in order.

**Right and Left Dot LEDs**

If an error occurred in two or more devices with the same rightmost byte in their IP addresses, the Right Dot LED will be lit while the devices' error is being displayed.

**Example: Displaying the Following Errors**

- A d6 error (failed to establish connection) occurred with IP address 10.0.1.8.
- A d6 error (failed to establish connection) occurred with IP address 10.0.2.8.

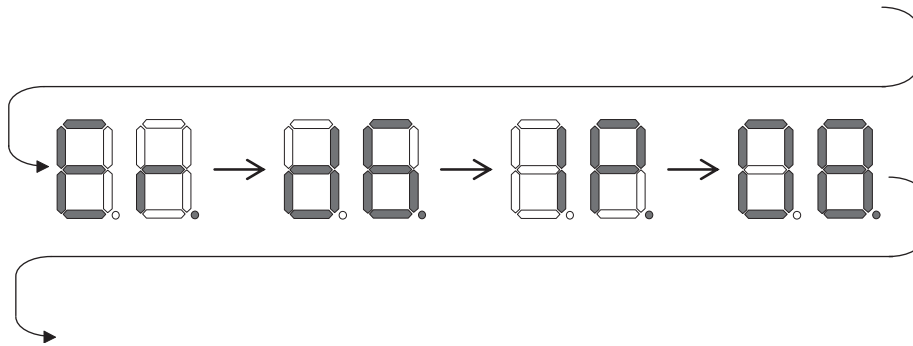

**2-2-2 Switch Settings**

**Unit Number Setting Switch**

The Unit Number Setting Switch sets the unit number of the EtherNet/IP Unit or built-in EtherNet/IP port as a CPU Bus Unit. The unit number determines which data area words are allocated to the Unit to contain data such as control bits, flags, status information, and connection information.



Setting method	Setting range
One-digit hexadecimal	0 to F

**Note** The unit number is factory-set to 0.

The unit number can be set to any number in the setting range (0 to F), as long as the same number is not set on another CPU Bus Unit in the same PLC.

- Note**
- (1) Use a small screwdriver to make the setting, and be sure not to damage the rotary switch.
  - (2) Always turn OFF the PLC's power supply before setting the unit number.
  - (3) The unit number is factory-set to 0.
  - (4) If the same unit number is set on more than one CPU Bus Unit mounted in a PLC, a unit number duplication error will occur in the PLC and the EtherNet/IP Unit or built-in EtherNet/IP port will not be able to start operating.

**Node Address Setting Switch**

The Node Address Setting Switch sets the node address of the EtherNet/IP Unit or built-in EtherNet/IP port.



Setting method	Setting range
Two-digit hexadecimal	01 to FE

**Note** The node address is factory-set to 01. With the default settings, the values set on these switches become the last two digits of the local IP address of the EtherNet/IP Unit or built-in EtherNet/IP port.  
 Default IP address = 192.168.250.node address  
 With the factory-default node address setting of 01, the default IP address is 192.168.250.1.

The node address can be set to any number in the setting range (01 to FE), as long as the same address is not set on another node in the network.

**Note** If the node address setting is changed during operation, the MS Indicator will flash red.



## 2-3 Selecting the Network Devices

### 2-3-1 Recommended Network Devices

The following table shows the devices recommended for use with the EtherNet/IP.

Part	Maker	Model number	Inquires
Switching Hub	Cisco Systems, Inc.	Consult the manufacturer.	Cisco Systems, Inc. Main Corporate HQ
	Contec USA, Inc.	Consult the manufacturer.	CONTEC USA Inc.
	Phoenix Contact	Consult the manufacturer.	Phoenix Contact USA Customer Service
	Hirschmann Automation and Control	Consult the manufacturer.	Hirschmann Automation and Control (US)
Twisted-pair cable	100BASE-TX		
	Fujikura	F-LINK-E 0.5mm × 4P	Fujikura America, Inc.
	EtherNet/IP compliant cable		---
Connectors (Modular plug)	STP Plug		
	Panduit Corporation	MPS588	Panduit Corporation US Headquarters
Boots	Tsuko Company	MK boot (IV) LB	Tsuko Company Japan Headquarters

- Note**
- (1) Always use a switching hub when using tag data links in the network.
  - (2) If a repeater hub is used for EtherNet/IP tag data links (cyclic communications), the network's communications load will increase, data collisions will occur frequently, and stable communications will be impossible.

### 2-3-2 Network Devices Manufactured by OMRON

The following network devices are manufactured by OMRON for EtherNet/IP networks.

Name	Model	Function	Number of ports	Error detection output
Switching Hub	W4S1-03B	Packet priority control (QoS): EtherNet/IP control data priority	3	None
	W4S1-05B	Failure detection: Broadcast storm, LSI error detection, 10/100Base-TX, Auto-Negotiation	5	None
	W4S1-05C		5	Provided.

### 2-3-3 Switching Hub Types

#### Unmanaged Layer 2 (L2) Switching Hubs

These switching hubs use the Ethernet MAC address to switch ports. Ordinary switching hubs have this function. Switching hub functions and settings cannot be changed.

#### Managed Layer 2 (L2) Switching Hubs

These switching hubs use the Ethernet address to switch ports. Switching hub functions and settings can be changed using special software tools for switching hubs running on a network node. Analytical data can also be collected. These switching hubs provide more-advanced functions than unmanaged layer 2 switching hubs.

### 2-3-4 Switching Hub Functions

This section describes the switching hub functions that are important when using an EtherNet/IP network. When using an EtherNet/IP Unit, set the following two functions.

- Multicast filtering
- QoS (Quality of Service) for TCP/UDP port numbers (L4)

#### Multicast Filtering

Multicast filtering transfers multicast packets to the specific nodes only. This function is implemented in the switching hub as IGMP Snooping or GMRP. "Specific nodes" are nodes equipped with an IGMP client that have made transfer requests to the switching hub. (OMRON EtherNet/IP Units are equipped with an IGMP client.)

When the hub does not use multicast filtering, multicast packets are sent to all nodes, just like broadcast packets, which increases the traffic in the network. Settings must be made in the switching hub to enable this function.

There must be enough multicast filters for the network being used.

#### QoS (Quality of Service) Function for TCP/UDP Port Numbers (L4)

This function controls the priority of packet transmissions so that packets can be sent with higher priority to a particular IP address or TCP (UDP) port. The TCP and UDP protocols are called transport layer protocols, leading to the name L4 (layer 4) QoS function.

When tag data links and message communications are executed on the same network, tag data links can be sent at higher priority to prevent problems such as transmission delays due to message communications traffic and packet losses due to buffer overflow. Settings must be made in the switching hub to enable this function and give higher priority to tag data link packets.

Support for the above two functions is as follows for the different types of switching hubs.

Hub	Multicast filtering	L4 QoS	Remarks
Unmanaged L2 switching hub	None	None	---
Managed L2 switching hub	Provided.	Provided.	Both functions must be set with a special software tool.
OMRON W4S1-series Switching Hubs	None	Provided.	L4 QoS is set using a switch. No software tool is necessary.

**Note** If the Network Configurator is used to set the connection type in the connection settings to a multicast connection, multicast packets will be used. If the connection type is set to a point-to-point connection, multicast packets will not be used.

### 2-3-5 Precautions When Selecting a Switching Hub

The functions supported by the switching hub may affect tag data link transmission delays and the configuration. In addition, if the switching hub supports advanced functions, special settings are required for those functions.

When selecting a switching hub, it is necessary to consider whether the switching hub will be selected based on the kind and amount of communications that will be performed in the network or the kind of switching hub that you want to use. Refer to the following precautions when selecting a switching hub.

Refer to *10-2 Adjusting the Communications Load* to estimate the communications load for tag data links.

### **Selecting the Switching Hub Based on the Types of Network Communications**

#### **Executing Tag Data Links Only**

We recommend using an L2 switching hub without multicast filtering or an L2 switching hub with multicast filtering.

Using an L2 switching hub with multicast filtering prevents increased traffic due to unnecessary multicast packets, so the tag data links can operate at higher speed. If either of the following conditions exists, the amount traffic will be the same for both kinds of L2 switching hubs (with or without multicast filtering).

- The tag data links are set to share the same data with all nodes in the network. (The multicast packets are transferred to all nodes in the network, just like a broadcast.)
- The tag data link settings are all one-to-one (unicast) and multicast packets cannot be used.

If multicast filters are being used, settings must be made in the switching hub. There must be enough multicast filters for all of the networks being used.

#### **Executing Tag Data Links and Message Communications**

We recommend using an L2 switching hub with multicast filtering and L4 QoS. By setting tag data links for higher-priority transmission, it is possible to prevent problems such as transmission delays due to message communications traffic and packet losses due to buffer overflow. Settings must be made in the switching hub to enable this function and give higher priority to tag data link packets.

Special settings must be made in the switching hub when using the multicast filtering function and L4 QoS function.

### **Selecting the Switching Hub Based on the Hub's Supported Functions**

#### **L2 Switching Hub without Multicast Filtering**

We recommend this kind of switching hub when only tag data links are executed and any of the following conditions is met.

- The tag data links are set to share the same data with all nodes in the network. (The multicast packets are transferred to all nodes in the network, just like a broadcast.)
- The tag data link settings are all one-to-one (unicast) and multicast packets cannot be used.
- There is little traffic in the tag data links.

No special settings are required for an L2 switching hub without multicast filtering.

#### **L2 Switching Hub with Multicast Filtering**

We recommend this kind of switching hub when only tag data links are executed and the following condition is met.

- There are many 1:N links (where N represents some number of nodes in the network) in the tag data link settings, i.e., there are many multicast packets used, or there is heavy traffic in the tag data links.

Special settings are required for an L2 switching hub with multicast filtering. There must be enough multicast filters for the network being used.

**L3 Switching Hub with Multicast Filtering and L4 QoS Functions**

We recommend this kind of switching hub when both tag data links and message communications are executed.

By setting tag data links for higher-priority transmission, it is possible to prevent problems such as transmission delays due to message communications traffic and packet losses due to buffer overflow. Settings must be made in the switching hub to enable this function and give higher priority to tag data link packets.

Special settings must be made in the switching hub when using the multicast filtering function and L4 QoS function. There must be enough multicast filters for the network being used.

**Note**

- (1) Ask the switching hub manufacturer for setting procedures for the switching hub.
- (2) Install the switching hub so that its environmental resistance capabilities are not exceeded. Ask the switching hub manufacturer for information on the environmental resistance of the switch hub.

# SECTION 3

## Installation and Initial Setup

This section explains how to install and make the initial settings required for operation of the EtherNet/IP Unit or built-in EtherNet/IP port.

3-1	Overview of Initial Setup Procedures . . . . .	34
3-1-1	Procedures. . . . .	34
3-2	Switch Settings . . . . .	36
3-2-1	CS-series EtherNet/IP Units . . . . .	36
3-2-2	CJ-series EtherNet/IP Units and CJ2 Built-in EtherNet/IP Port. . . . .	37
3-3	Mounting to a PLC . . . . .	38
3-3-1	Mounting to a CS-series PLC. . . . .	38
3-3-2	Mounting to a CJ-series PLC . . . . .	38
3-3-3	Mounting. . . . .	39
3-3-4	Handling Precautions . . . . .	40
3-4	Network Installation . . . . .	41
3-4-1	Basic Installation Precautions. . . . .	41
3-4-2	Recommended Products . . . . .	41
3-4-3	Precautions . . . . .	41
3-4-4	Using Contact Outputs (Common to All Units). . . . .	43
3-5	Connecting to the Network . . . . .	44
3-5-1	Ethernet Connectors . . . . .	44
3-5-2	Connecting the Cable . . . . .	44
3-6	Creating I/O Tables . . . . .	46
3-6-1	I/O Table Overview. . . . .	46
3-6-2	Connecting Programming Devices to the PLC. . . . .	46
3-6-3	Procedure for Creating I/O Tables . . . . .	46
3-7	Setting the Local IP Address. . . . .	50
3-8	TCP/IP and Link Settings . . . . .	52
3-8-1	Setting Procedure with the CX-Programmer . . . . .	52
3-8-2	Making TCP/IP Settings with the Network Configurator . . . . .	56
3-9	Tag Data Link Parameters. . . . .	58
3-9-1	Network Configurator Setting Procedure . . . . .	58
3-10	Other Parameters. . . . .	62
3-11	Communications Test . . . . .	66
3-11-1	PING Command. . . . .	66
3-11-2	EtherNet/IP Unit or Built-in EtherNet/IP Port Operation. . . . .	66
3-11-3	Host Computer Operation. . . . .	66

## 3-1 Overview of Initial Setup Procedures

### 3-1-1 Procedures

#### Initial Settings

- 1,2,3...
1. Set the unit number and node address with the switches on the front of the EtherNet/IP Unit or, for the built-in EtherNet/IP port, on the front of the CPU Unit.  
Refer to *3-2 Switch Settings*.
  2. Mount the Unit in the CPU Rack.  
A maximum of seven EtherNet/IP Units can be connected to a CJ2H-CPU□□-EIP CPU Unit (making eight EtherNet/IP ports including the built-in EtherNet/IP port).  
A maximum of two EtherNet/IP Units can be connected to a CJ2M CPU Unit (regardless of whether the CPU Unit has a built-in port).  
Refer to *3-3 Mounting to a PLC*.
  3. Wire the Ethernet network with twisted-pair cable.  
Refer to *3-4 Network Installation* and *3-5 Connecting to the Network*.
  4. Prepare a computer with Support Software installed on it and a serial cable or an Ethernet cable (twisted-pair cable) to connect to the PLC. These are required to perform network settings using the Support Software (e.g., Network Configurator, CX-Programmer, and CX-Integrator).
  5. Connect the PLC to the computer and create the I/O tables using the CX-Programmer. I/O tables do not need to be created for the built-in EtherNet/IP port on the CJ2H-CPU□□-EIP or CJ2M-CPU□□.  
Refer to *3-6 Creating I/O Tables*.
  6. Set the IP address of the EtherNet/IP Unit or built-in EtherNet/IP port using one of the following methods.
    - a) Using the Unit without setting the IP address:
      - The default IP address is *192.168.250.Node\_address*.
    - b) Setting a particular IP address:
      - If you want to store the setting in the CPU Unit, set it in the EtherNet/IP Unit's allocated DM area within the CPU Unit.
      - If you want to store the setting in the Unit, set the IP address in the Edit Parameters Dialog Box of the I/O Table Dialog Box from the CX-Programmer, and transfer the setting to the Unit.Refer to *3-7 Setting the Local IP Address* and *3-8 TCP/IP and Link Settings*.
  7. When necessary, set the following items in the Edit Parameters Dialog Box and transfer them: TCP/IP, Ethernet, FINS/UDP, FINS/TCP, FTP, Auto Adjust Time, Status Area, SNMP, and SNMP Trap  
Refer to *3-10 Other Parameters*.
  8. When necessary, set the routing tables.  
If the FINS communications service is being used and multiple network Communications Units are mounted in the PLC, set the routing tables from the CX-Integrator, and transfer the table.  
Refer to the *CX-Integrator Operation Manual* (Cat. No. W464) for the setting procedure.

9. Test communications.  
Send a PING command to the EtherNet/IP Unit or built-in EtherNet/IP port.  
Refer to *3-11 Communications Test*.

### **Settings Required for Tag Data Link Service (Cyclic Communications)**

#### **1. Using the EtherNet/IP Datalink Tool in the Network Configurator to Set the Parameters**

With this method, there is no flexibility in the settings, but you can easily set the data link parameters using only memory addresses, and the settings will conform to Controller Link data link parameters. Refer to *3-9 Tag Data Link Parameters* or *SECTION 6 Tag Data Link Functions*.

#### **2. Using the Tag Data Link Setting Function in the Network Configurator to Set the Parameters**

With this method, you can set the connections that define the tag data links for each EtherNet/IP node. Tag data links can be set with a high degree of flexibility using both memory addresses and network variables. Refer to *SECTION 6 Tag Data Link Functions* for information on how to make these settings.

### **Settings Required for the Message Communications Service**

Execute a CMND(490) instruction in the CS/CJ-series CPU Unit's user program.

Refer to *SECTION 9 Message Communications*.

## 3-2 Switch Settings

### 3-2-1 CS-series EtherNet/IP Units

#### Setting the Unit Number

The unit number is used to identify individual CPU Bus Units when more than one CPU Bus Unit is mounted to the same PLC. Use a small screwdriver to make the setting, taking care not to damage the rotary switch. The unit number is factory-set to 0.

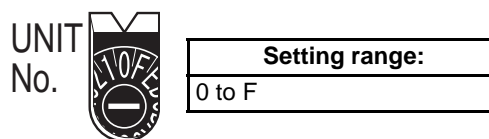

- Note**
- (1) Turn OFF the power supply before setting the unit number.
  - (2) If the unit number is being set for the first time or changed, then I/O tables must be created for the PLC.
  - (3) With CS-series and CJ-series PLCs, words are automatically allocated in the CIO Area and DM Area according to the unit numbers that are set. For details, refer to *SECTION 4 Memory Allocations*.

#### Setting the Node Address

When there are multiple EtherNet/IP Units or Ethernet Units connected to the Ethernet network for the FINS communications service, the EtherNet/IP Units are identified by node addresses. Use the node address switches (NODE NO.) to set the node address between 01 and FE hexadecimal (1 to 254 decimal). Do not set a number that has already been set for another node on the same network.



The left switch sets the sixteens digit (most significant digit) and the right switch sets the ones digit (least significant digit). The node address is factory-set to 01.

- Note** Turn OFF the power supply before setting the node address.

#### **Relationship to IP Addresses**

When IP addresses are generated automatically (either dynamic or passive), the rightmost byte of the host ID of the IP address is set to the same value as the node address. (Refer to *Section 5 Determining IP Addresses*.) If the same node address value cannot be used, the IP address table method or the combined method must be used for address conversion. (For details, refer to *SECTION 5 Determining IP Addresses*.)

If the FINS communications service is not being used on the Ethernet network, then it is all right for the same node address to be set on two or more EtherNet/IP Units. The setting, however, must be made within a range of 01 to FE. If a value outside of this range is set, the MS indicator will light red, the 7-segment display will indicate code H4 (node address setting error), and the EtherNet/IP Unit will stop operating.



## 3-2-2 CJ-series EtherNet/IP Units and CJ2 Built-in EtherNet/IP Port

### Setting the Unit Number

The unit number is used to identify individual CPU Bus Units when more than one CPU Bus Unit is mounted to the same PLC. Use a small screwdriver to make the setting, taking care not to damage the rotary switch. The unit number is factory-set to 0.

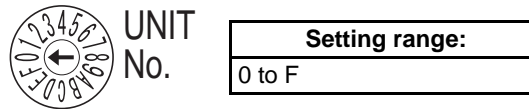

- Note**
- (1) Turn OFF the power supply before setting the unit number.
  - (2) If the unit number is being set for the first time or changed, then I/O tables must be created for the PLC.
  - (3) With CS-series and CJ-series PLCs, dedicated areas are automatically allocated in the CIO Area and DM Area according to the unit numbers that are set. For details, refer to *SECTION 4 Memory Allocations*.

### Setting the Node Address

With the FINS communications service, when there are multiple EtherNet/IP Units connected to the Ethernet network, the EtherNet/IP Units are identified by node addresses. Use the node address switches to set the node address between 01 and FE hexadecimal (1 to 254 decimal). Do not set a number that has already been set for another node on the same network.

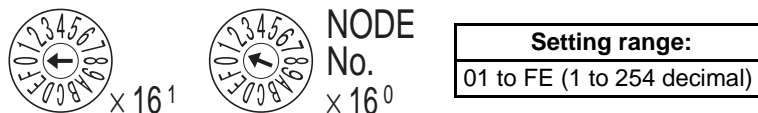

The left switch sets the sixteens digit (most significant digit) and the right switch sets the ones digit (least significant digit). The node address is factory-set to 01.

- Note** Turn OFF the power supply before setting the node address.

#### Relationship to IP Addresses

When IP addresses are generated automatically (either dynamic or passive), the rightmost byte of the host ID of the IP address of the EtherNet/IP Unit or built-in EtherNet/IP port is set to the same value as the node address. (Refer to *Section 5 Determining IP Addresses*.) If the same node address value cannot be used, the IP address table method or the combined method must be used for address conversion. (For details, refer to *SECTION 5 Determining IP Addresses*.)

If the FINS communications service is not being used on the Ethernet network, then it is all right for the same node address to be set on two or more EtherNet/IP Units or built-in EtherNet/IP ports. The setting, however, must be made within a range of 01 to FE. If a value outside of this range is set, the MS indicator will light red, the 7-segment display will indicate code H4 (node address setting error), and the EtherNet/IP Unit or built-in EtherNet/IP port will stop operating.

### 3-3 Mounting to a PLC

#### 3-3-1 Mounting to a CS-series PLC

EtherNet/IP Units can be mounted to any slot in a CS-series CPU Rack or a CS-series Expansion CPU Rack, but the number of slots to which they can be mounted depends on the Backplane. A maximum of eight EtherNet/IP Units can be mounted in a single PLC. If one or more EtherNet/IP Units are mounted in combination with other CPU Bus Units (e.g., Controller Link Units), the maximum total number of CPU Bus Units that can be mounted is 16.

**Note** Tighten PLC Backplane mounting screws to a torque of 0.9 N·m, and the Unit's screws to a torque of 0.4 N·m.

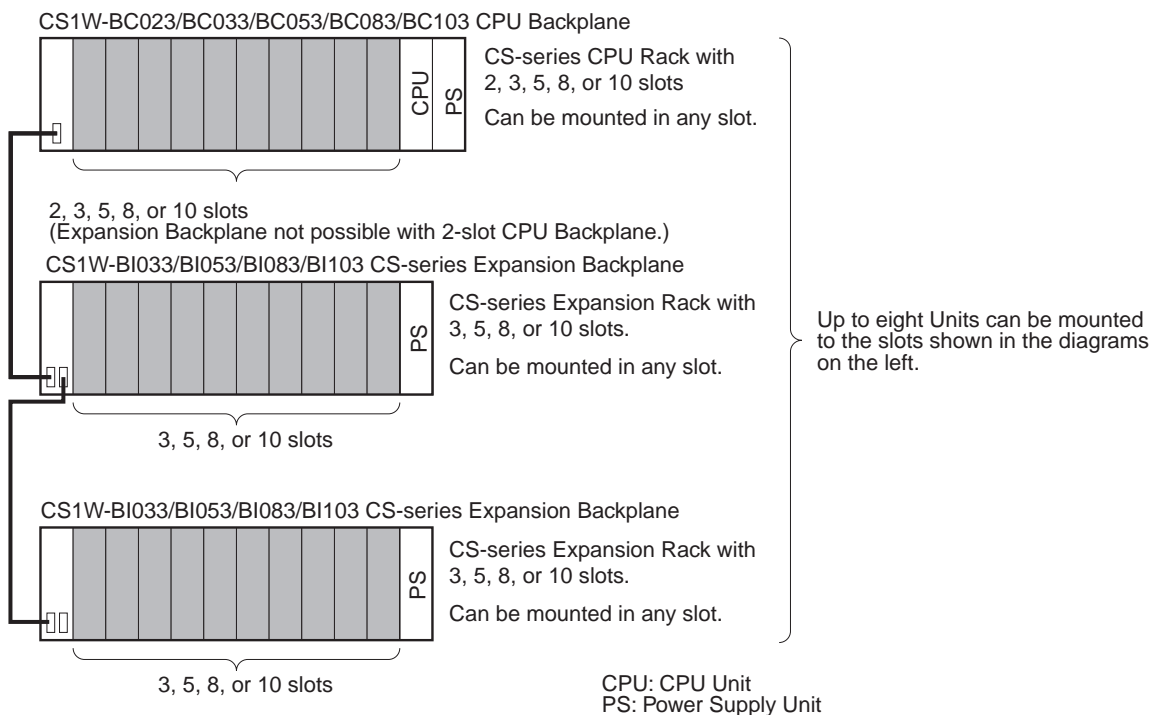

**Note** The CS1W-EIP21 EtherNet/IP Unit's maximum current consumption is 410 mA. Be sure that the total current consumption of all the Units connected to the same CPU Backplane or Expansion Backplane does not exceed the output capacity of the Power Supply Unit.

#### 3-3-2 Mounting to a CJ-series PLC

EtherNet/IP Units can be mounted in a CJ-series CPU Rack or a CJ-series Expansion CPU Rack. Connect the EtherNet/IP Unit in any of the positions shown below using the sliders on the top and bottom of the Unit. Up to seven EtherNet/IP Units can be mounted for a CJ2H-CPU□□-EIP CPU Unit (enabling up to eight EtherNet/IP ports if you include the built-in EtherNet/IP port). Up to two EtherNet/IP Units can be mounted for a CJ2M CPU Unit (regardless of whether the CPU Unit has a built-in port).

If EtherNet/IP Units are mounted in combination with other CPU Bus Units (e.g., Controller Link Units), the maximum total number of CPU Bus Units that can be mounted is 16.

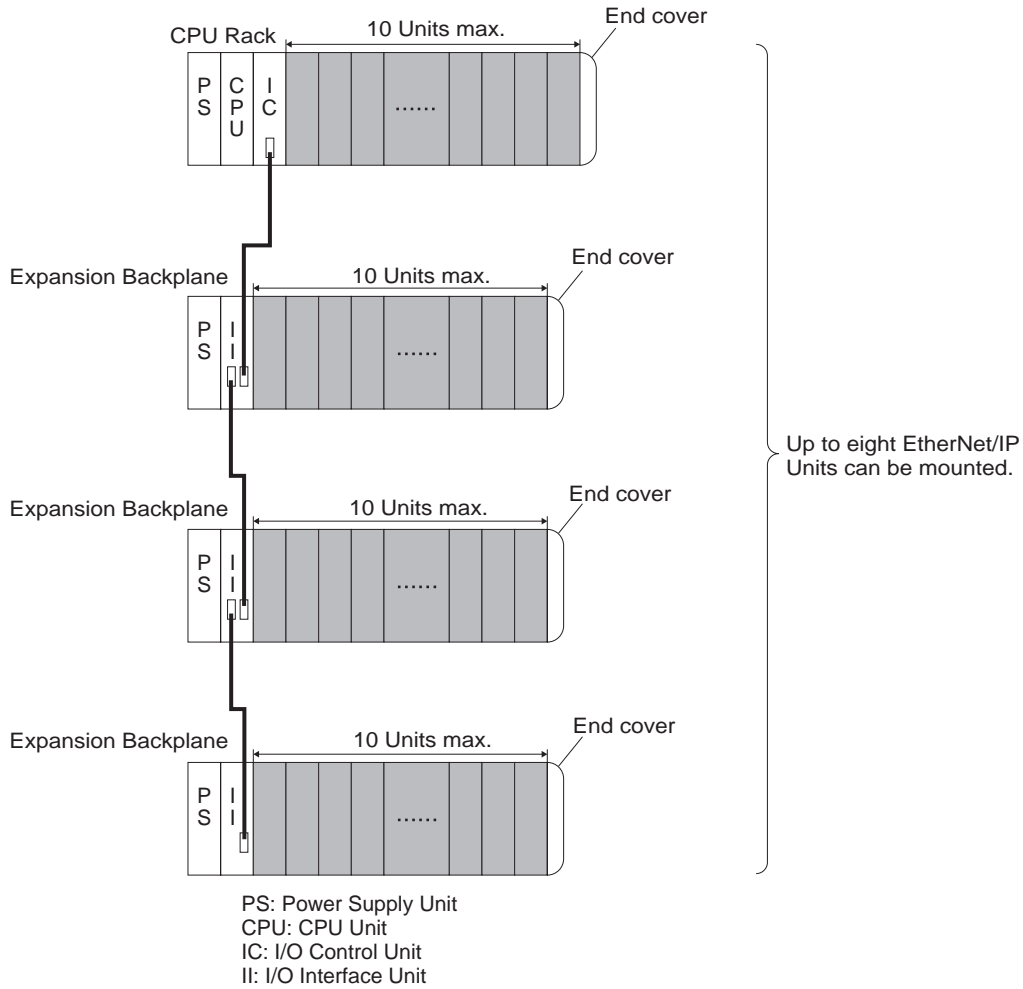

**Note** The CJ1W-EIP21 EtherNet/IP Unit's maximum current consumption is 410 mA. Be sure that the total current consumption of all the Units connected to the same CPU Backplane or Expansion Backplane does not exceed the output capacity of the Power Supply Unit.

### 3-3-3 Mounting

Mount the EtherNet/IP Unit to the Backplane using the following procedure.

- 1,2,3... 1. Hook the claw on the top of the Unit onto the Backplane.

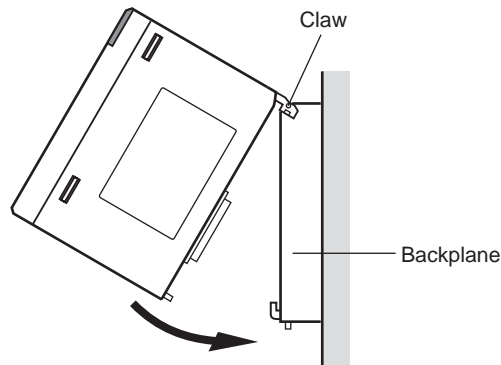

2. Insert the Unit into Backplane connectors and securely tighten the screw at the bottom of the Unit. Tighten the screws to a torque of 0.4 N·m.

- When removing the Unit, first loosen the screw at the bottom of the Unit.

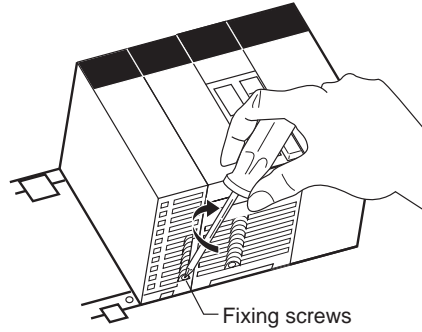

**Note** When mounting the Unit, provide the clearance shown below to facilitate easy mounting or dismounting.

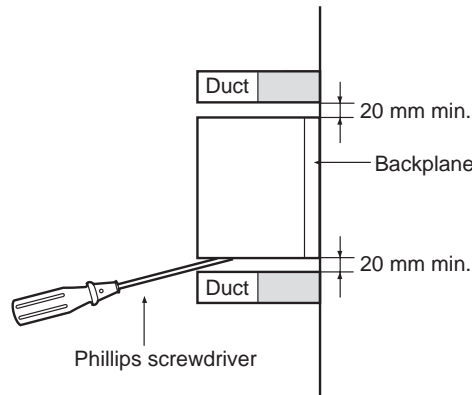

### 3-3-4 Handling Precautions

- Always turn OFF the power supply to the PLC before mounting or dismounting a Unit or connecting or disconnecting cables.
- Provide separate conduits or ducts for the I/O lines to prevent noise from high-tension lines or power lines.
- Leave the label attached to the Unit when wiring. Removing the label may result in malfunction if wire clippings or other foreign matter enters the Unit. Remove the label after the completion of wiring to ensure proper heat dissipation. Leaving the label attached may result in malfunction.

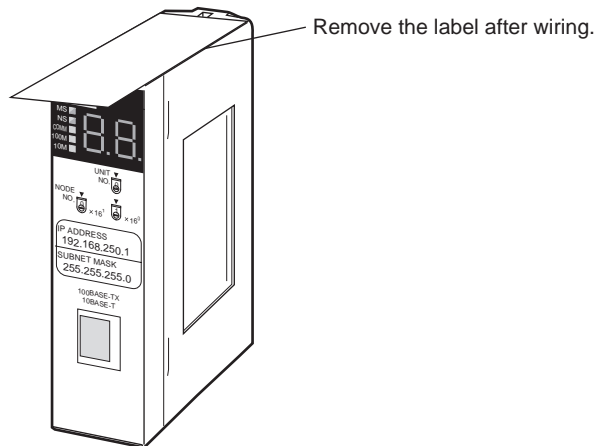

### 3-4 Network Installation

#### 3-4-1 Basic Installation Precautions

- Take the greatest care when installing the Ethernet System, being sure to follow ISO 8802-3 specifications. You must obtain a copy of these specifications and be sure you understand them before attempting to install an Ethernet System. Unless you are already experienced in installing communications systems, we strongly recommend that you employ a professional to install your system.
- Do not install Ethernet equipment near sources of noise. If a noisy environment is unavoidable, take adequate measures against noise interference, such as installing network components in grounded metal cases or using optical cable in the system.
- When installing an EtherNet/IP network that combines an information system with the control system, and the communications load may be heavy due to tag data links, we recommend configuring the network so that the load does not affect communications. For example, install the tag data links in a segment that is separate from the information network.

**Note** The maximum current consumption of the CS1W-EIP21 and CJ1W-EIP21 EtherNet/IP Units is 410 mA. Be sure that the total current consumption of all the Units connected to the same CPU Backplane or Expansion Backplane does not exceed the output capacity of the Power Supply Unit.

#### 3-4-2 Recommended Products

The following table shows the devices recommended for use with the EtherNet/IP Unit 2-3 *Selecting the Network Devices*.

#### 3-4-3 Precautions

##### Precautions on Laying Twisted-pair Cable

- Incorrect handling of the shield or grounding of the devices can create ground loops. Ground loops may lower noise immunity and may destroy the devices. Handle the shield as described below and ground it at only one point.
- Do not connect the shield to the EtherNet/IP Unit's connector.
- If a cable connects two hubs, connect the shields at only one end.

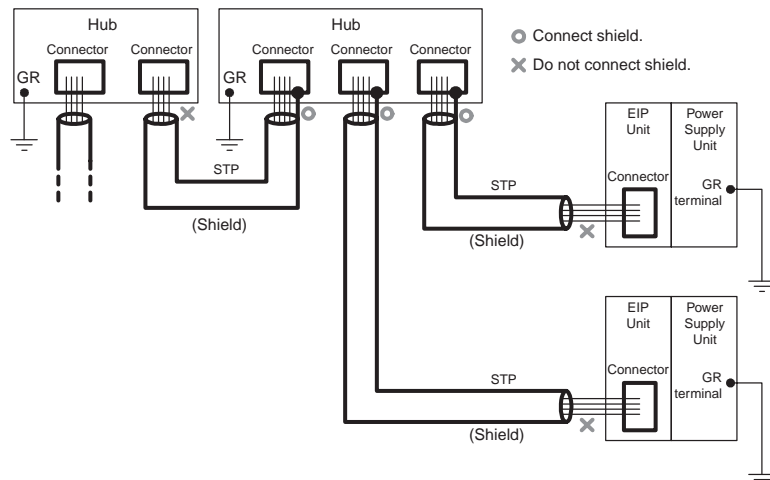

- Press the cable connector in firmly until it locks into place at both the switching hub and the EtherNet/IP Unit.
- Do not lay the twisted-pair cable together with high-voltage lines.
- Do not lay the twisted-pair cable near devices that generate noise.
- Do not lay the twisted-pair cable in locations subject to high temperatures or high humidity.
- Do not lay the twisted-pair cable in locations subject to excessive dirt and dust or to oil mist or other contaminants.

**Switching Hub Installation Environment Precautions**

- Do not ground the switching hub in the same location as a drive-system component such as an inverter.
- Always use a dedicated power supply for the switching hub’s power supply. Do not use the same power supply used for other equipment, such as an I/O power supply, motor power supply, or control power supply.
- Before installation, check the switching hub’s environment-resistance specifications, and use a switching hub appropriate for the ambient conditions. Contact the switching hub manufacturer for details on switching hub’s environment-resistance specifications.

**Switching Hub Connection Methods**

Connect two hubs to each other as follows: Connect an MDI port to an MDI-X port with a straight cable; connect two MDI ports with a cross cable; and connect two MDI-X ports with a cross cable.

**Note** It is very difficult to distinguish cross cables and straight cables by appearance. Incorrect cables will cause communications to fail. We recommend using cascade connections with straight cables whenever possible.

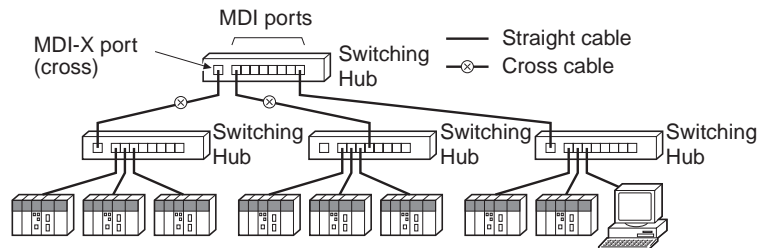

Some switching hubs can automatically distinguish between MDI and MDI-X. When this kind of switching hub is being used, straight cable can be used between switching hubs.

**Note** Adjust the link settings of the EtherNet/IP Unit or built-in EtherNet/IP port to match the communications settings of the connected switching hub. If the settings do not match, the link will become unstable and prevent normal communications. The following table shows the allowed settings for each switching hub communications mode.

Switching hub setting		EtherNet/IP Unit setting				
		Auto-negotiation	10 Mbps (fixed)		100 Mbps (fixed)	
			Full duplex	Half duplex	Full duplex	Half duplex
Auto-negotiation		Best	---	OK	---	OK
10 Mbps (fixed)	Full duplex	---	OK	---	---	---
	Half duplex	OK	---	OK	---	---

Switching hub setting		EtherNet/IP Unit setting				
		Auto-negotiation	10 Mbps (fixed)		100 Mbps (fixed)	
			Full duplex	Half duplex	Full duplex	Half duplex
100 Mbps (fixed)	Full duplex	---	---	---	Best	---
	Half duplex	OK	---	---	---	OK

**Note** Best = Recommended; OK = Allowed; --- = Not allowed.

### 3-4-4 Using Contact Outputs (Common to All Units)

When an EtherNet/IP Unit or built-in EtherNet/IP port and Contact Output Unit are mounted in the same Rack or connected to the same PLC, communications errors may occur due to noise generated by the contact outputs. Use one or more of the following measures when installing Contact Output Units and EtherNet/IP Units on the same Rack.

#### Mounting Location

Mount (or connect) any Contact Output Units as far away from the EtherNet/IP Unit or built-in EtherNet/IP port as possible.

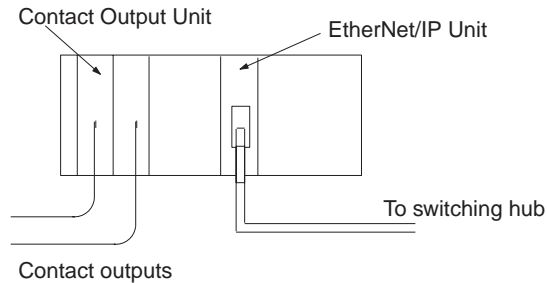

#### Cable Location

Separate the transceiver cable or twisted-pair cable connecting the EtherNet/IP Unit as far from the wiring to the Contact Output Units as possible. The coaxial cable must also be placed as far away from the Contact Output Units and their wiring as possible.

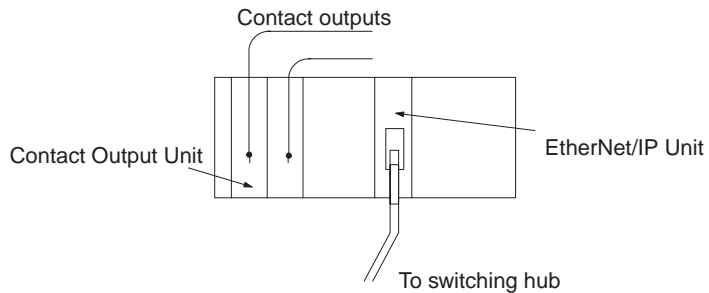

### 3-5 Connecting to the Network

#### 3-5-1 Ethernet Connectors

The following standards and specifications apply to the connectors for the Ethernet twisted-pair cable.

- Electrical specifications: Conforming to IEEE802.3 standards.
- Connector structure: RJ45 8-pin Modular Connector (conforming to ISO 8877)

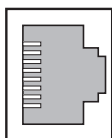

Connector pin	Signal name	Abbr.	Signal direction
1	Transmission data +	TD+	Output
2	Transmission data -	TD-	Output
3	Reception data +	RD+	Input
4	Not used.	---	---
5	Not used.	---	---
6	Reception data -	RD-	Input
7	Not used.	---	---
8	Not used.	---	---
Hood	Frame ground	FG	---

#### 3-5-2 Connecting the Cable

**⚠ Caution** Turn OFF the PLC's power supply before connecting or disconnecting twisted-pair cable.

**⚠ Caution** Allow enough space for the bending radius of the twisted-pair cable as shown in below.

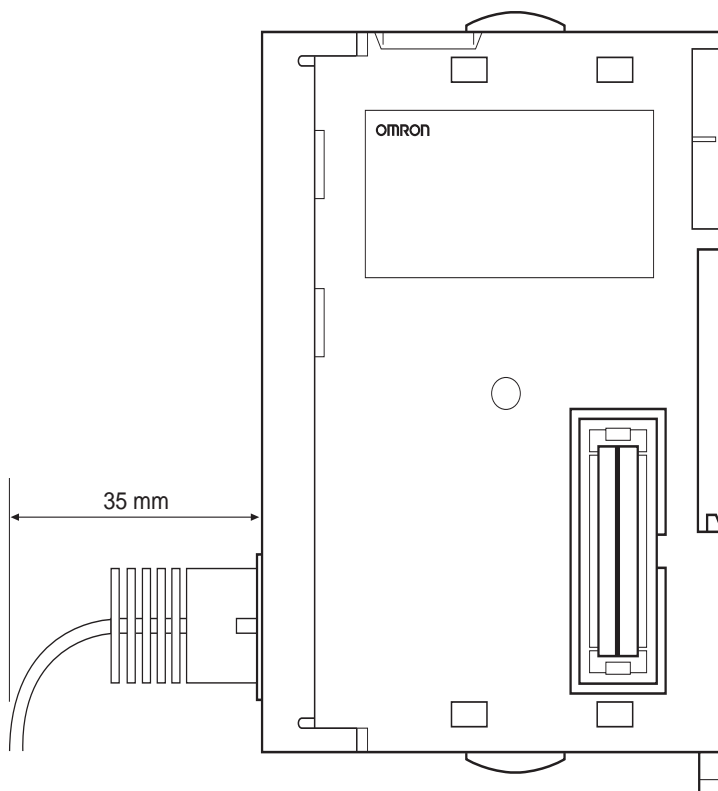



- 1,2,3...**
1. Lay the twisted-pair cable.
  2. Connect the cable to the switching hub. Be sure to press in the cable until it locks into place.
  3. Connect the twisted-pair cable to the connector on the EtherNet/IP Unit. Be sure to press the connectors (both the switching hub side and Ethernet side) until they lock into place.

Example: CS1W-EIP21

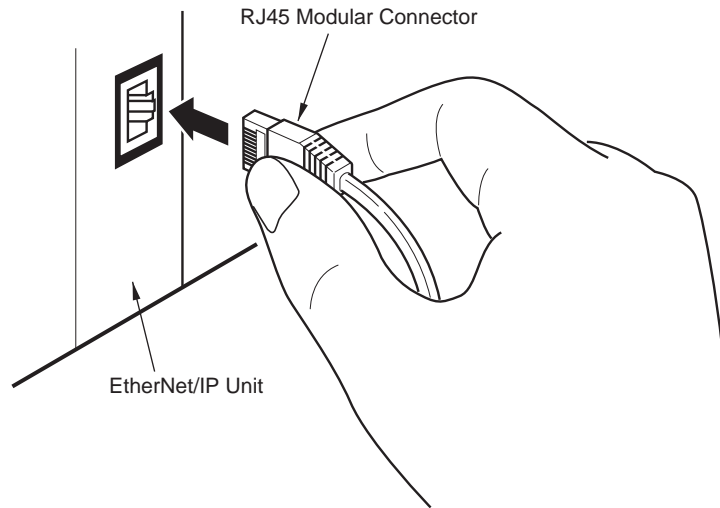

## 3-6 Creating I/O Tables

### 3-6-1 I/O Table Overview

I/O tables are used to identify Units mounted to the PLC, and to allocate I/O to them. With CS-series and CJ-series PLCs, whenever there is a change to the Unit configuration it is necessary to create I/O tables and register the mounted Units in the CPU Unit.

The I/O tables can be created in the following ways.

- Using the CX-Programmer offline.
- Using the CX-Programmer online to create the I/O table based on the Units mounted to the PLC.
- Using the Programming Console to create the I/O table based on the Units mounted to the PLC.
- Using the CPU Unit's automatic I/O allocation at startup. (This method is available for the CJ Series only.)

### 3-6-2 Connecting Programming Devices to the PLC

To create the I/O tables, connect a Programming Device (such as a CX-Programmer or Programming Console) to the PLC.

#### Applicable Programming Devices

The following Programming Devices can be used with CS/CJ-series PLCs.

#### Programming Console

Model number	Key Sheet (required)	Recommended cable (required)
C200H-PRO27-E	CS1W-KS001-E	CS1W-CN224 (cable length: 2.0 m)
		CS1W-CN624 (cable length: 6.0 m)
CQM1-PRO01-E		CS1W-CN114 (cable length: 0.1 m)

**Note** A Programming Console cannot be used with the CJ2H-CPU□□(-EIP) and CJ2M-CPU3□ CPU Units. Use the CX-Programmer.

#### CX-Programmer

For information on how to connect and operate the CX-Programmer, refer to the *CX-Programmer Operation Manual* (Cat. No. W446).

#### Connecting a Programming Console

To connect a Programming Console, attach a CS/CJ-series Key Sheet and then connect the Console to the CPU Unit's peripheral port. (It cannot be connected to the RS-232C port.)

### 3-6-3 Procedure for Creating I/O Tables

#### Programming Console

This section provides the procedure for creating the I/O tables using a Programming Console. For details on using the Programming Console, refer to the Programming Console's operation manual.

- Note**
- (1) With the CJ Series, it is necessary to create I/O tables only when the user is allocating I/O manually. With the CS Series, it is always necessary to create I/O tables.

(2) With the CJ2H-CPU□□-EIP and CJ2M-CPU3□ CPU Units, the built-in EtherNet/IP port is set in the I/O tables by default and cannot be changed. It is not necessary to register it in the I/O tables.

Use the following procedure to create the I/O tables.

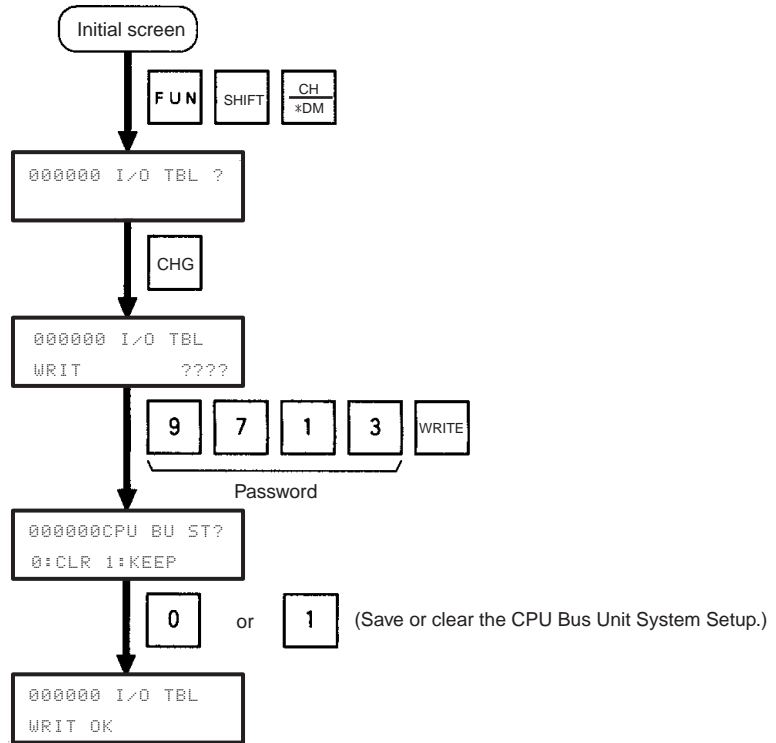

**CX-Programmer (Version 8.0 or Higher)**

This section describes how to register an EtherNet/IP Unit or built-in EtherNet/IP port in the I/O tables using the CX-Programmer (version 8.0 or higher). Refer to the *CX-Programmer Operation Manual* (Cat. No. W446) for details on the operating procedures.

This section describes how to register the CJ1W-EIP21 in the I/O tables by creating the I/O tables on a computer with the CX-Programmer. In this example, the computer is connected to the PLC using a serial cable. The CJ1W-EIP21 is connected to a CJ1H-CPU67 CPU Unit.

- 1,2,3... 1. Start the CX-Programmer, and then select **PLC – Auto Online – Direct Connection** from the menus.

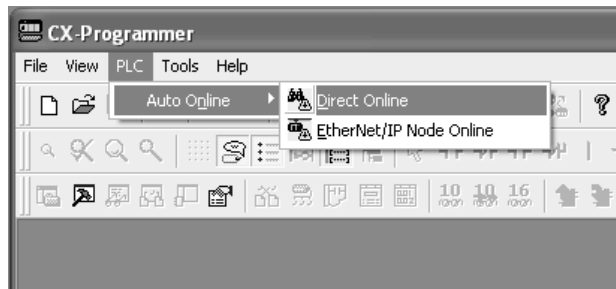

- The Direct Online Dialog Box will be displayed. Select a serial connection, select the name of the applicable computer serial port, and then press the Connect Button.

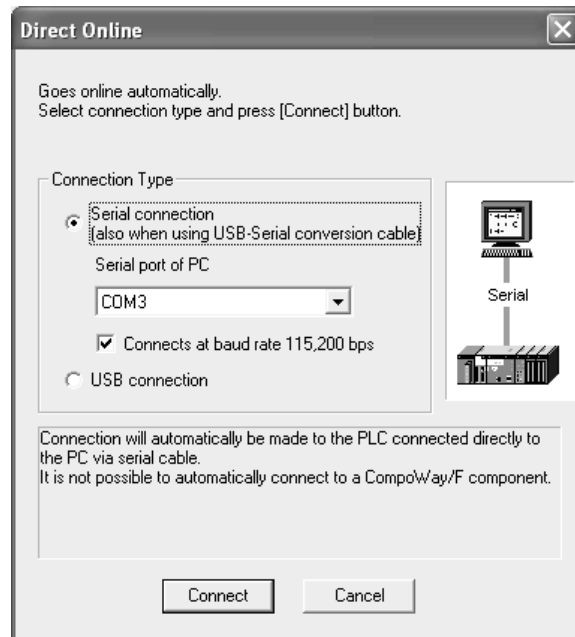

- If the connection process is successful, the system will be connected on-line. Here, check the operating mode of the PLC. If the operating mode is not PROGRAM mode, change the mode by selecting **PLC – Operating Mode – Program** from the menus.
- Double-click **IO Table and Unit Setup** Icon in the project workspace in the CX-Programmer. The PLC IO Table Window will be displayed. Select **Options – Create** from the menus.

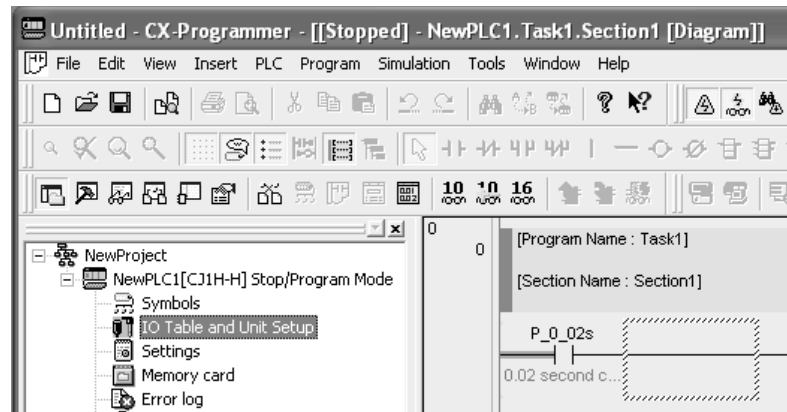

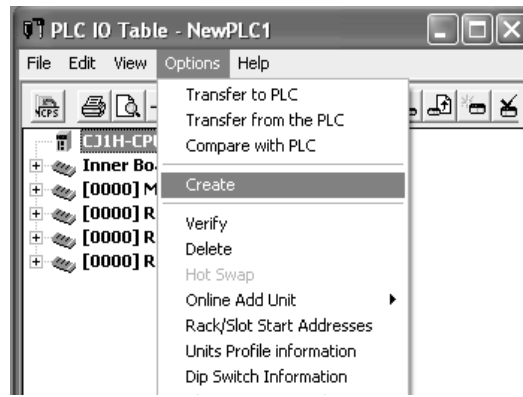

- The EtherNet/IP Unit will be displayed at the position it is mounted in the PLC.

**Note** If it is not displayed, select **Options – Transfer from PLC** from the menus.

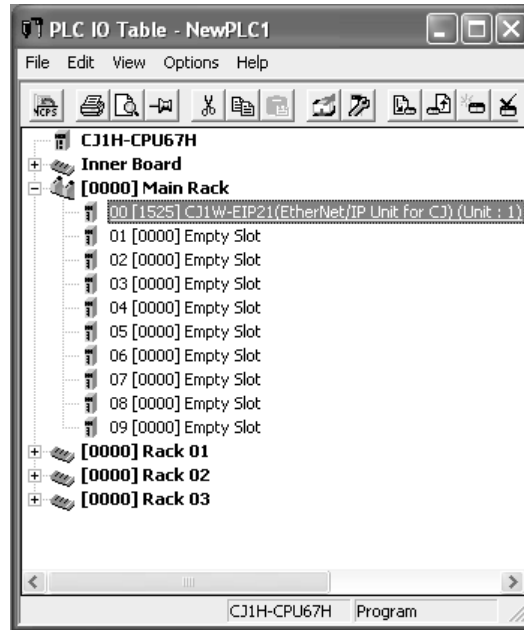

**Note** Creating I/O tables is not required if the built-in EtherNet/IP port of a CJ2 CPU Unit is used. It is registered as a built-in port/Inner Board with a model number of CJ2B-EIP21 for the CJ2H and a model number of CJ2M-EIP21 for the CJ2M. You cannot delete a built-in port from the I/O tables.

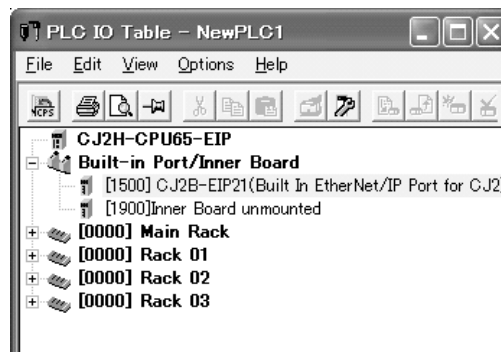

## 3-7 Setting the Local IP Address

This section describes the 3 ways to set the local I/O address of an EtherNet/IP Unit or built-in EtherNet/IP port.

Method 1: Using the default IP address:

The default IP address is *192.168.250.Node\_address*.

(The node address is set with the rotary switches on the front of the EtherNet/IP Unit or, for the built-in EtherNet/IP port, on the front of the CPU Unit.)

→ This method can be used to make a temporary or preliminary connection to the Ethernet. In this case, leave the TCP/IP Configuration and the allocated DM area IP address settings at their default values (0.0.0.0).

Method 2: Setting an IP address in the CPU Unit's allocated DM area:

→ If you want to set a particular local IP address and store that setting in the CPU Unit, set it in the EtherNet/IP Unit's allocated DM area. The IP address can be set from the CX-Programmer, Programming Console, or ladder program.

Method 3: Setting the TCP/IP Configuration from the CX-Programmer:

→ If you want to set a particular local IP address and store that setting in the EtherNet/IP Unit, set the IP address from the CX-Programmer.

When FINS communications are being used, it is necessary to show the correspondence between the IP addresses and FINS node addresses. Refer to *SECTION 5 Determining IP Addresses* for an explanation of IP addresses as well as the correspondence between FINS node addresses and IP addresses.

The three setting methods are described in the following paragraphs.

### **Method 1: Using the Default IP Address (192.168.250.Node\_address)**

When the EtherNet/IP Unit or built-in EtherNet/IP port is just mounted in the PLC and the I/O table is created, the EtherNet/IP Unit or built-in EtherNet/IP port will operate with its default IP address. This default address is enabled when the local IP address in the allocated DM area and the TCP/IP Configuration are both set to their defaults (0.0.0.0).

The default IP address is *192.168.250.Node\_address*, where *Node\_address* is the node address set with the rotary switches on the front of the EtherNet/IP Unit. This address is also used as the FINS node address.

The following table shows the various settings in the Unit Setup when the IP address and TCP/IP Configuration are all set to their default values.

Setting	Operating status
IP address	192.168.250.Node_address
Subnet mask	255.255.255.0 (class C mask)
Default gateway	None (IP routing disabled)
Preferred DNS server	None
Alternate DNS server	None
Host name	None
Domain name	None
Baud rate	Auto-detect

**Method 2: Setting the Address in the CPU Bus Unit's Allocated DM Area**

With this method, an IP address is not set in the TCP/IP Configuration (left at its default setting), and an IP address is set in the allocated DM Area words (the IP Address Display/Setting Area in words m+98 and m+99).

The IP address can be written in the two IP Address Display/Setting Area words using the CX-Programmer or the Programming Console. To enable the new IP Address setting, the EtherNet/IP Unit or built-in EtherNet/IP port must be restarted or the PLC's power must be turned OFF and then ON again.

Beginning word m = D30000 + (100 x unit number)

	15	14	13	12	11	10	9	8	7	6	5	4	3	2	1	0
m+98	(1)				(2)				(3)				(4)			
m+99	(5)				(6)				(7)				(8)			

IP Address: (1)(2).(3)(4).(5)(6).(7)(8) (Hex)

The following table shows the various Unit Setup when only the IP Address Display/Setting Area is set, and the other TCP/IP Configuration settings are left at their default values.

Setting	Operating status
IP address	IP address set in words m+98 and m+99 (IP Address Display/Setting Area) of the DM Area words allocated to the EtherNet/IP Unit as a CPU Bus Unit
Subnet mask	Determined by class of the IP address
Default gateway	None (IP routing disabled)
Preferred DNS server	None
Alternate DNS server	None
Host name	None
Domain name	None
Baud rate	Auto-detect

**Method 3: Setting the TCP/IP Configuration from the Network Configurator**

This method can be used to set IP addresses from the CX-Programmer. For details, refer to 3-8 TCP/IP and Link Settings.

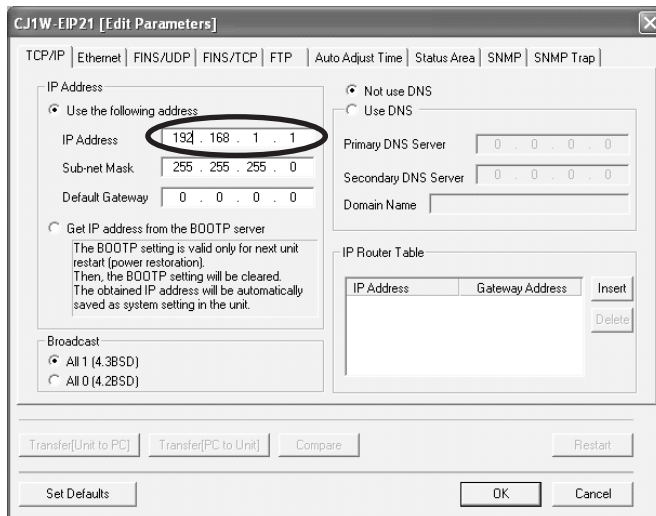

If the IP address is set in the TCP/IP Tab Page, that IP address setting will be displayed in the IP Address Display/Setting Area (words m+98 and m+99) in the DM Area words allocated to the Unit/port.

### 3-8 TCP/IP and Link Settings

This section describes the TCP/IP-related settings, such as the local IP address and subnet mask for the EtherNet/IP Unit or built-in EtherNet/IP port. Use the CX-Programmer to make these settings. The settings are stored in non-volatile memory in the Unit.

**Note** Unlike the Ethernet Units, the TCP/IP settings of the EtherNet/IP Unit and built-in EtherNet/IP port are not stored in the CPU Unit's CPU Bus Unit System Setup Area.

#### 3-8-1 Setting Procedure with the CX-Programmer

- 1,2,3... 1. When the EtherNet/IP Unit is registered in the I/O tables of the CX-Programmer, the EtherNet/IP Unit and built-in EtherNet/IP port will be displayed in the I/O tables. Refer to 3-6 *Creating I/O Tables* for details.

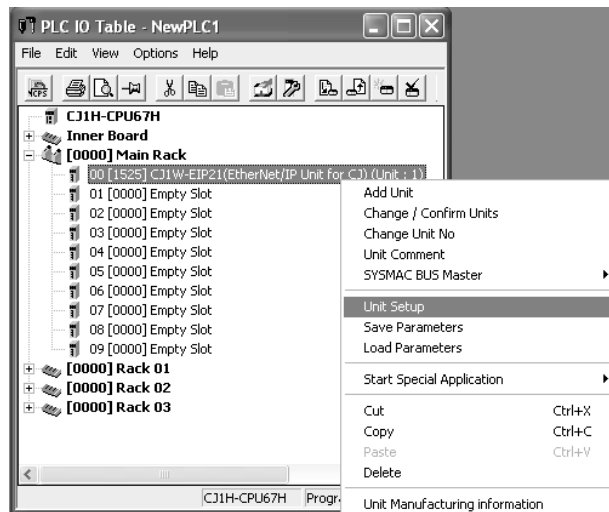

2. Right-click the EtherNet/IP Unit or built-in EtherNet/IP port in the I/O table and select **Edit - Unit Setup** from the menus. The Edit Parameters Dialog Box will be displayed.

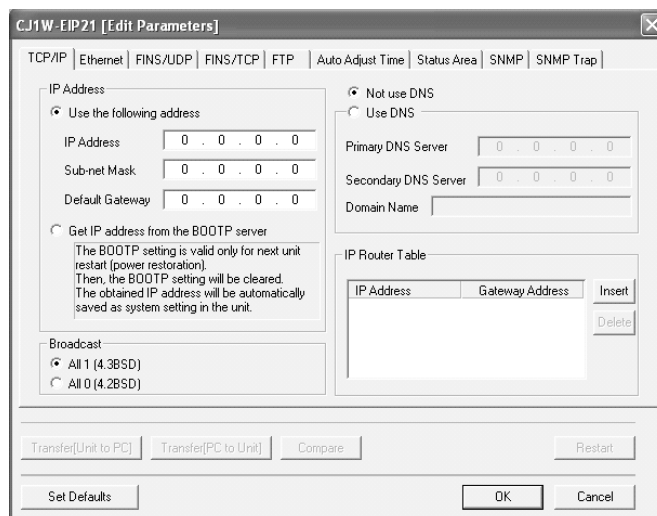

3. Make the necessary settings on the TCP/IP Tab Page of the Edit Parameters Dialog Box. (The IP address is set here.)



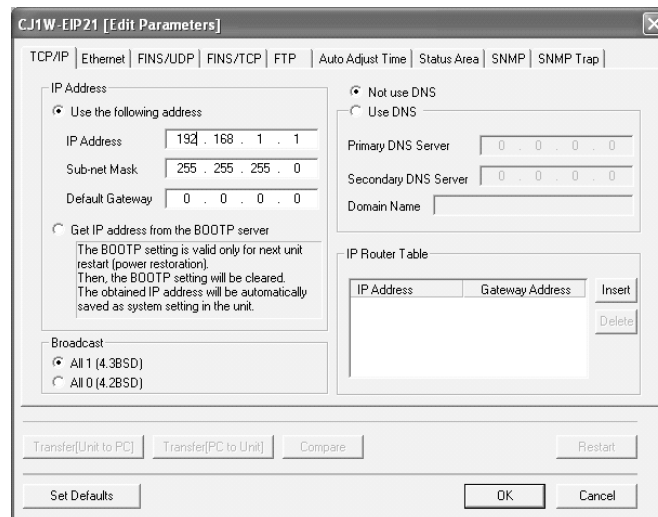

4. Place the CX-Programmer online with the PLC and transfer the settings to the EtherNet/IP Unit or built-in EtherNet/IP port.
5. After transferring the settings, a message will ask if you want to restart the EtherNet/IP Unit or built-in EtherNet/IP port. The Unit/port must be restarted to enable the settings.
6. Check the 7-segment display for the EtherNet/IP Unit or built-in EtherNet/IP port.
7. If the 7-segment display is tested again after it goes OFF, and finally displays the IP address, it indicates that the EtherNet/IP Unit has recognized the new TCP/IP Configuration settings (the IP address in this case).

**Note**

- (1) The EtherNet/IP Unit or built-in EtherNet/IP port must restart in order to enable the parameter settings that are transferred to it. Verify that restarting the Unit/port will not cause any problems in the system before restarting it.
- (2) If the target node address (IP address) is not set correctly, invalid device parameters may be set in the wrong PLC, so check the connected PLC before downloading parameters.

### Settings on the TCP/IP Tab Page

Settings for the following items are provided on the TCP/IP Tab Page of the Edit Parameters Dialog Box in the CX-Programmer.

- IP address
- Subnet mask
- Default gateway
- Broadcasting
- Preferred DNS server
- Alternate DNS server
- Domain name
- IP router table

**IP Address**

Sets the local IP address of the EtherNet/IP Unit or built-in EtherNet/IP port.

Set the local IP address on the TCP/IP Tab Page when not setting the IP address in the CPU Unit's allocated DM Area or using the default IP address (default IP address = 192.168.250.Node\_address).

When the IP address is set on the TCP/IP Tab Page, it will be stored as the IP address in the DM Area words allocated to the Unit/port as a CPU Bus Unit.

**Subnet Mask**

For the subnet mask, all bits corresponding to the bits in the IP address used as the network ID are set to 1, and the bits corresponding to the host number are set to 0. The EtherNet/IP Unit or built-in EtherNet/IP port supports CIDR (Classless Inter-Domain Routing). The subnet mask can be set to 192.0.0.0 to 255.255.255.252. (CIDR is supported by unit version 2.0 or later.)

If no subnet mask is set, or if an illegal value is set, the following values will be used depending on the IP address class.

In normal applications, we recommend setting the subnet mask defined for the class.

Class	Subnet mask
Class A	255.0.0.0
Class B	255.255.0.0
Class C	255.255.255.0

With the default setting (0.0.0.0), a subnet mask corresponding to the IP address class is used.

The following table shows the various parameters in the Unit Setup when only the IP address and subnet mask are set and other settings are left at their default values.

Setting	Operating status
Default gateway	None (IP routing disabled)
Preferred DNS server	None
Alternate DNS server	None
Host name	None
Domain name	None
Broadcasting	4.3 BSD specifications
IP router table	None

**Default Gateway**

Sets the default gateway's IP address.

This setting is not required when the default gateway is not being used.

**Broadcasting**

Sets the IP address specification method for broadcasting with FINS/UDP.

- All 1's (4.3BSD): Broadcasting is performed with the host ID set to all 1's.
- All 0's (4.2BSD): Broadcasting is performed with the host ID set to all 0's.

Normally, use the default setting of all 1's (4.3BSD).

**Preferred DNS Server and Alternate DNS Server**

When accessing another node from the EtherNet/IP Unit or built-in EtherNet/IP port using the host name, the DNS server searches for the other node's IP address from the other node's host name to the DNS server. These settings register the IP addresses of the preferred and alternate DNS servers that will perform the search. At this time, the EtherNet/IP Unit is not equipped with any

functions that require a DNS server, so these settings are not used. (The functionality required to use a DNS server is not provided on EtherNet/IP Units with unit version 1.0. The DNS server cannot be used with these Units.)

**Domain Name**

Sets the domain name of the domain to which the EtherNet/IP Unit or built-in EtherNet/IP port belongs. The EtherNet/IP Unit or built-in EtherNet/IP port does not use a domain name in actual communications.

**IP Router Table**

The IP router table is used to find the IP address of the IP router that is connected to the target segment. This is done when performing communications with a node that is on an IP network segment that is connected to the EtherNet/IP Unit through an IP router. The IP router table is set when EtherNet/IP Unit communications are routed to a specific node through any IP router other than the default gateway.

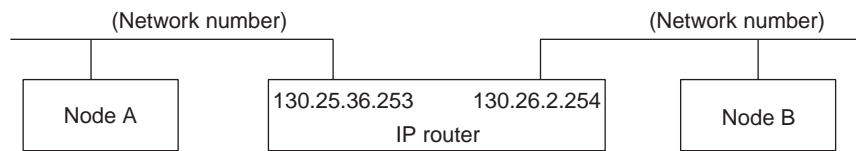

For the IP address in the table, set the network ID of the other IP network segment to communicate with. The length of the network ID in bytes depends on the IP address class. The IP address can be set to four bytes. Set the network ID from the beginning of the text box and enter zeros for any unused digits. You can set up to eight records. No records are set in the default settings.

**Settings on the Ethernet Tab Page**

The following settings are provided on the Ethernet Tab Page of the Unit Setup for the EtherNet/IP Unit or built-in EtherNet/IP port.

- Link settings (baud rate and half/full duplex)

**Link Setting**

Sets the communications baud rate.

Setting	Meaning
Auto (default)	The baud rate with the switching hub is detected automatically. If possible, the Unit operates in 100Base-T (full duplex).
10 Mbps, Half Duplex	Operates in 10Base-T, half duplex.
10 Mbps, Full Duplex	Operates in 10Base-T, full duplex.
100 Mbps, Half Duplex	Operates in 100Base-TX, half duplex.
100 Mbps, Full Duplex	Operates in 100Base-TX, full duplex.

**Note** Adjust the EtherNet/IP Unit's link settings to match the communications settings of the connected switching hub. If the settings do not match, the link will become unstable and prevent normal communications. The following table shows the allowed settings for each switching hub communications mode.

Switching hub setting		EtherNet/IP Unit setting				
		Auto-negotiation	10 Mbps (fixed)		100 Mbps (fixed)	
			Full duplex	Half duplex	Full duplex	Half duplex
Auto-negotiation		Best	---	OK	---	OK
10 Mbps (fixed)	Full duplex	---	OK	---	---	---
	Half duplex	OK	---	OK	---	---

100 Mbps (fixed)	Full duplex	---	---	---	Best	---
	Half duplex	OK	---	---	---	OK

**Note** Best = Recommended; OK = Allowed; --- = Not allowed.

### 3-8-2 Making TCP/IP Settings with the Network Configurator

Use the Network Configurator to change IP address settings for any device other than a CS/CJ-series EtherNet/IP Unit or built-in port. You can also use the Network Configurator to change IP address settings for a CS/CJ-series EtherNet/IP Unit or built-in port.

- 1,2,3...**
1. Connect the Network Configurator online.  
Refer to 6-2-9 *Connecting the Network Configurator to the Network* for details on connecting the Network Configurator to the EtherNet/IP Unit.
  2. Select **Tools - Setup TCP/IP Configuration** to display the following Setup TCP/IP Configuration Dialog Box, and set the TCP/IP Configuration for the target device. In the following example, the settings are all at their default values.

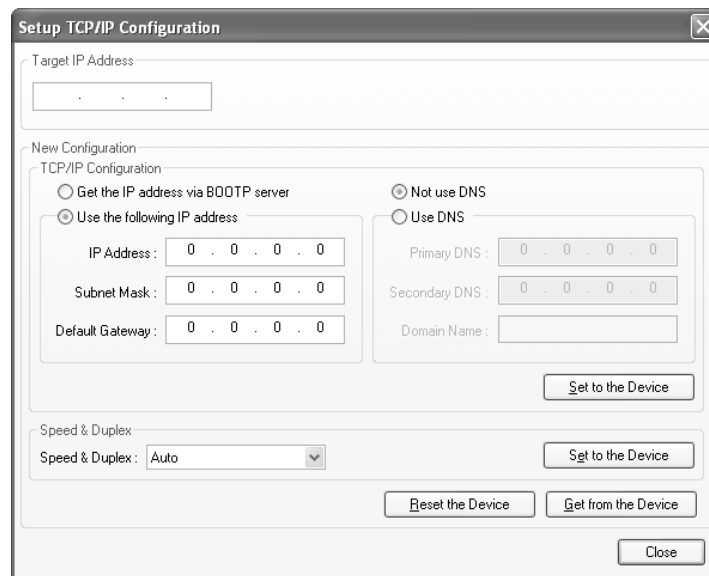

3. Enter the IP address to set and press the **Get from the Device** Button. The present setting will be obtained. Change the IP address in the *New Configuration* Box if required.

4. Press the **Set to the Device** Button. The IP address will be transferred to the device. The applicable device is the device specified in the *Target IP Address* Box. The device must be reset to enable the transferred setting. If the device is not reset when the new IP address is transferred, click the **Reset the Device** Button.

When the EtherNet/IP Unit is reset, the IP address will be displayed once in flowing text on the 7-segment display on the front of the Unit.

**Note**

- (1) The transfer function for IP address settings is defined by ODVA specifications. Target devices that do not support these specifications cannot be set. When setting the IP address of the target device with the Network Configurator, connect the devices one at a time, and download the TCP/IP Configuration's IP address parameters. If TCP/IP parameters are set for the EtherNet/IP Unit or built-in EtherNet/IP port from the Network Configurator, the EtherNet/IP Unit may automatically be reset and restarted. Before setting the TCP/IP parameters, make sure that no system problems will occur when the Unit is restarted. If the Unit does not restart automatically, click the **Reset the Device** Button.
- (2) If the target node address (IP address) is not set correctly, invalid device parameters may be set in the wrong PLC, so check the connected PLC before downloading parameters.

## TCP/IP Parameters

The following TCP/IP parameters can be set from the Network Configurator.

- IP address
- Subnet mask
- Default gateway
- Preferred DNS server
- Alternate DNS server
- Domain name
- Link parameters (baud rate and full/half duplex)

### 3-9 Tag Data Link Parameters

Set the following parameters when using tag data links with an EtherNet/IP Unit or built-in EtherNet/IP port. The parameter settings are saved in flash memory in the EtherNet/IP Unit or CPU Unit. (See note.)

**Note** The CPU Bus Unit Setup Area is not used for tag data link settings for an EtherNet/IP Unit or built-in EtherNet/IP port. This point is different from the operation of Ethernet Units.

Refer to *SECTION 6 Tag Data Link Functions* for details.

#### 3-9-1 Network Configurator Setting Procedure

The methods for setting tag data links using the Network Configurator can be roughly divided into the following two.

##### 1. Using the EtherNet/IP Datalink Tool in the Network Configurator to Set the Parameters

With this method, there is no flexibility in the settings, but you can easily set the data link parameters using only memory addresses, and the settings will conform to Controller Link data link parameters.

##### 2. Using the Tag Data Link Setting Function in the Network Configurator to Set the Parameters

With this method, you can set the connections that comprise the tag data links for each EtherNet/IP node. Tag data links can be set with a high degree of flexibility using both memory addresses and network variables. Refer to *SECTION 6 Tag Data Link Functions* for details on how to perform these settings. This section presents a setting example using the EtherNet/IP Datalink Tool.

#### Using the EtherNet/IP Datalink Tool

The method that is described here is used to set memory addresses in tables to specify data links between EtherNet/IP Units or built-in EtherNet/IP ports on CS/CJ-series PLCs.

The following method can be used to easily set the data links shown in the following figure using a wizard in the EtherNet/IP Datalink Tool.

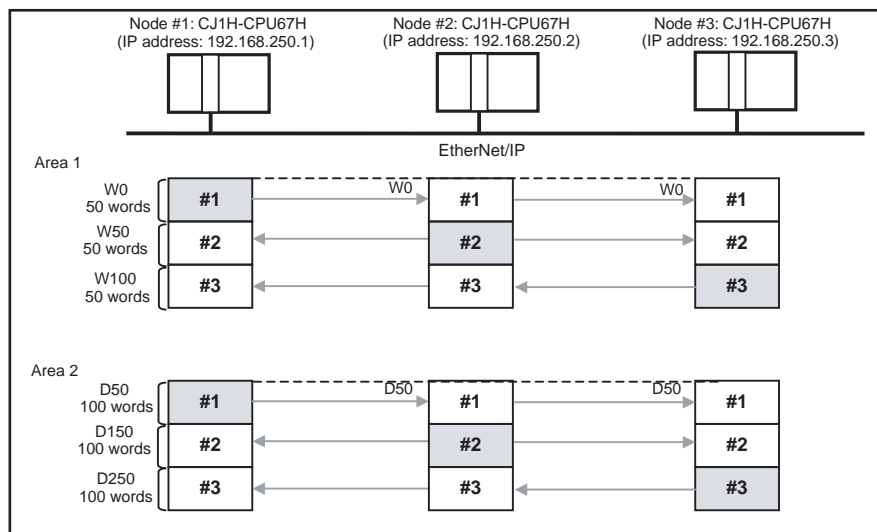

- 1,2,3...**
1. Start the Network Configurator, select the applicable EtherNet/IP Unit in the Tree View on the left, and then paste it into the Device Configuration Pane on the right.

**Note** If an EtherNet/IP system has already been installed, you can create a similar device configuration by connecting to the EtherNet/IP network and selecting **Network – Upload** from the menus. Refer to 6-2-9 *Connecting the Network Configurator to the Network* for information on connecting.

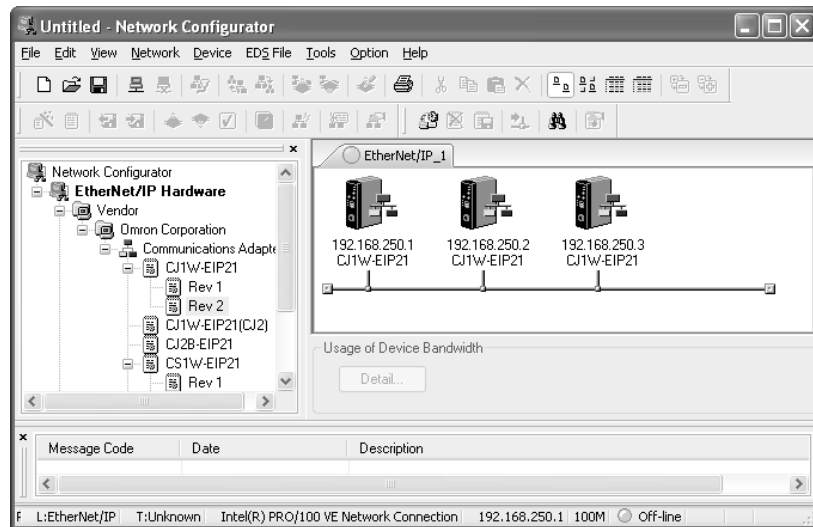

2. Select **Network – EtherNet/IP Datalink** Tool from the menus to start the EtherNet/IP Datalink Tool.
3. Select **Datalink – Wizard** from the menus in the Datalink Tool when it has started.

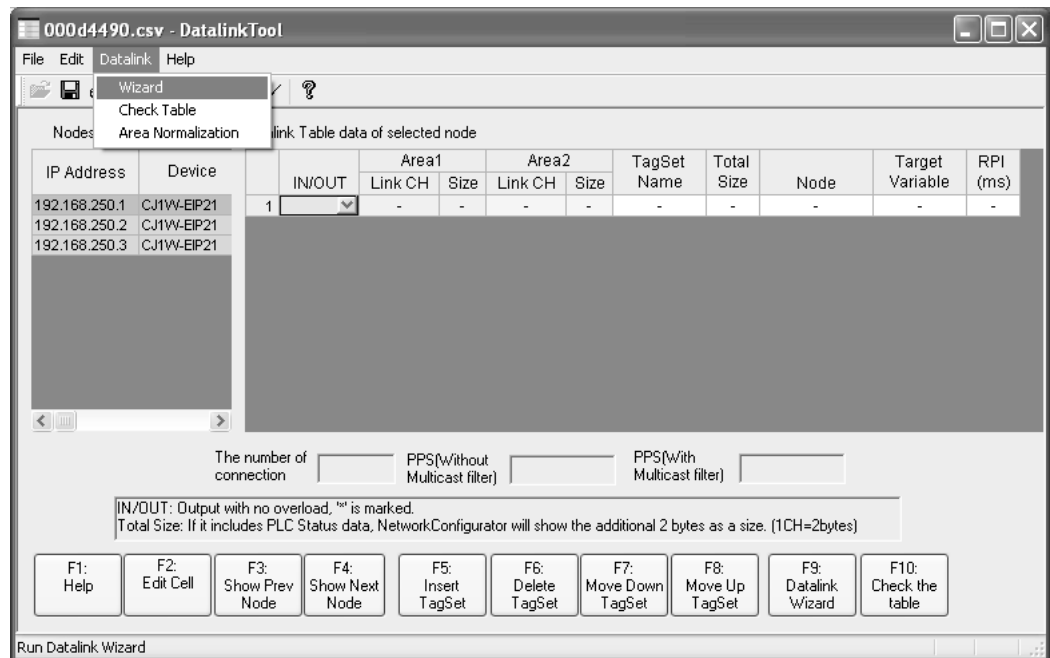

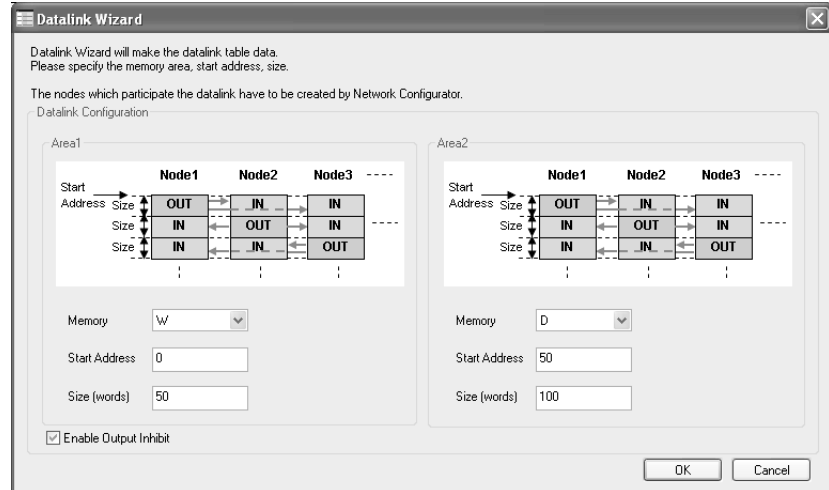

4. In the Datalink Wizard Dialog Box, enter 50 words starting from memory address W000 for area 1 and 100 words starting from D00050 for area 2,

and then press the **OK** Button.

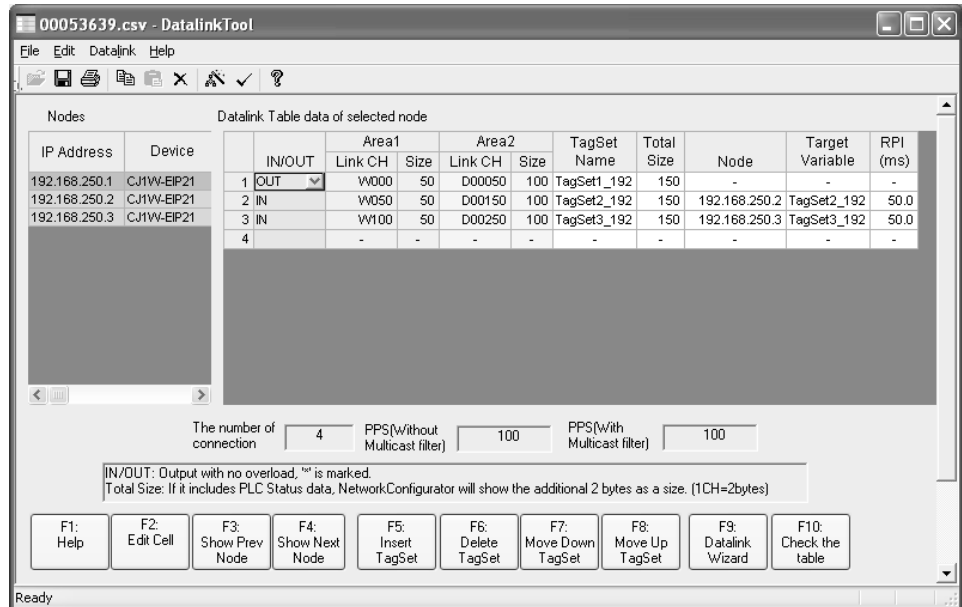

- The data link settings will be automatically created in the window of the EtherNet/IP Datalink Tool. Select **File – Save** to end. The settings will be saved in the Network Configurator.



- In the Device Configuration Window of the Network Configurator, a  mark will be added to each EtherNet/IP Unit to show that data links have



been set.

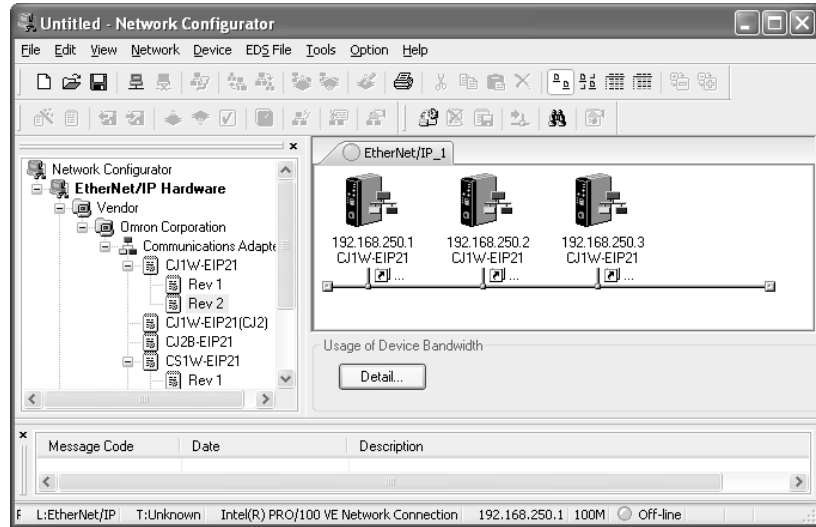

7. Connect the Network Configurator to the EtherNet/IP network and select **Network – Download** from the menus. The data link settings will be downloaded to the EtherNet/IP Units, and the data links will operate.

## 3-10 Other Parameters

In addition to the tag data link parameters, the EtherNet/IP Unit and built-in EtherNet/IP port also have the following communications and operation parameters.

- FINS/UDP
- FINS/TCP
- FTP
- Auto Adjust Time
- Status Area
- SNMP
- SNMP Trap

These parameters are set as Unit Setup from the CX-Programmer. The parameter settings are saved in flash memory in the EtherNet/IP Unit or CPU Unit. (See note.)

**Note** The CPU Bus Unit Setup Area is not used for tag data link settings for an EtherNet/IP Unit or built-in EtherNet/IP port. This point is different from the operation of Ethernet Units.

### Using FINS/UDP

Tab Page in Edit Parameters Dialog Box	Setting	Function
FINS/UDP	FINS/UDP Port	Specifies the local UDP port number to use in the FINS communications service. The UDP uses the UDP port number to distinguish the application layer (FINS communications service in this case). <ul style="list-style-type: none"> <li>• Default value (9,600)</li> <li>• User-set value (1 to 65,535)</li> </ul>
	Conversion	Selects one of the following methods to convert from the FINS node address to an IP address (FINS/UDP only). <ul style="list-style-type: none"> <li>• Automatic generation (dynamic setting)</li> <li>• Automatic generation (static setting)</li> <li>• IP address table</li> <li>• Combined method</li> </ul>
	IP Address Table	Sets the IP address table that defines the relationship between FINS node addresses and IP addresses. This table is effective only when FINS/UDP is being used and the IP address conversion method is set to the IP address table.
	Dynamic change the target IP addresses	Selects dynamic change of other FINS/UDP nodes' IP addresses. To disable dynamic changes, deselect this option by removing the check mark.

When necessary, set the routing tables using the CX-Integrator.

**Using FINS/TCP**

Tab Page in Edit Parameters Dialog Box	Setting	Function
FINS/TCP	FINS/TCP Port	Specifies the local TCP port number to use in the FINS communications service. The TCP uses the TCP port number to distinguish the application layer (FINS communications service in this case). <ul style="list-style-type: none"> <li>• Default value (9,600)</li> <li>• User-set value (1 to 65,535)</li> </ul>
	FINS/TCP Connection Setup	This is the network API used when TCP is used for the FINS communications service. Up to 16 APIs can be used at a time, and they are identified by connection numbers 1 to 16. The EtherNet/IP Unit or built-in EtherNet/IP port can thus simultaneously execute the FINS communications service by TCP with up to 16 remote nodes.
	Protection Setting	Select this check box to refuse connection requests from any IP address not set as the target IP address when the server/client setting is set to a server and the target IP address is set to any value other than 0.0.0.0.  This check box can be selected to prevent inappropriate operations on the PLC for FINS commands from specific nodes.

When necessary, set the routing tables using the CX-Integrator.

**Using FTP**

Tab Page in Edit Parameters Dialog Box	Setting	Function
FTP	Not Use FTP or Use FTP	Specifies whether to use FTP. FTP connections from external devices will not be possible if <i>Not Use FTP</i> is specified.
	Login	Sets the login name for FTP connections to the EtherNet/IP Unit or built-in EtherNet/IP port from external devices
	Password	Sets the password for FTP connections to the EtherNet/IP Unit or built-in EtherNet/IP port from external devices.
	Port No.	Sets the FTP port number of the EtherNet/IP Unit or built-in EtherNet/IP port.  It is normally not necessary to change this setting.  Two ports are used with the FTP: a control port and a data transfer port. Only the control port can be set. The data transfer port number will be one larger than the control port number.

**Using the Automatic Time Adjustment**

Tab Page in Edit Parameters Dialog Box	Setting	Function
Auto Adjust Time	Not get the time information from the SNTP server or Get the time information from the SNTP server	Specifies whether to set the clock in the CPU Unit to the time on the SNTP server. The time can be set only in CPU Units with an EtherNet/IP Unit or a built-in EtherNet/IP port.
	Auto Adjust time	Sets the time to access the SNTP server to automatically adjust the CPU Unit clock. When the specified time arrives, the SNTP server will be accessed and the clock in the CPU Unit will be set to the time on the SNTP server.
	Server Specification Type	Specifies whether to use an IP address or a domain name (i.e., host name) to specify the SNTP server to use for automatic time adjustment.
	IP Address	Sets the IP address of the SNTP server to use for automatic time adjustment. This IP address is valid only when the Server Specification Type is set to an IP address.
	Host Name	Sets the host name of the SNTP server to use for automatic time adjustment. This IP address is valid only when the Server Specification Type is set to a host name.
	Port No.	Sets the port number to use to connect to the SNTP server for automatic time adjustment. It is normally not necessary to change this setting.
	Retry Timer	Sets the time to wait before retrying the connection when connecting to the SNTP server fails. It is normally not necessary to change this setting.
	Adjust Time	Sets the time to offset the clock in the CPU Unit when setting the clock in the CPU Unit to the time obtained from the SNTP server. To use the time from the SNTP server as is, enter 0 for the Adjust Time.

**Using the Status Area**

Tab Page in Edit Parameters Dialog Box	Setting	Function
Status Area	Layout Type	Specifies whether to use the default setting or a custom setting for the words allocated to the status area.
	Allocation Area	Sets the first word in the status area when the Layout Type is set for a customer setting. With CS1/CJ1 CPU Units, only an I/O memory address can be set. With CJ2 or NE1S CPU Units, either an I/O memory address or a symbol defined in the CPU Unit can be set.

**Using SNMP**

Tab Page in Edit Parameters Dialog Box	Setting	Function
SNMP	Not use SNMP service or Use SNMP service	Specifies whether to use the SNMP. If not using the SNMP service is specified, an SNMP manager will not be able to connected from an external device.
	SNMP Port	Sets the port number to use when connecting from an SNMP manager. It is normally not necessary to change this setting.
	SNMP Contact Information	Specifies the contact information as text. This information can be read from the SNMP manager.
	SNMP Location Information	Specifies the location information as text. This information can be read from the SNMP manager.
	Authentication Check 1/2	Specifies the SNMP managers that can access the PLC. To restrict access to only specific SNMP managers, specify the SNMP managers using IP addresses or host names. Community names can also be specified (e.g., public). Either one or two settings can be made.

**Using SNMP Trap**

Tab Page in Edit Parameters Dialog Box	Setting	Function
SNMP Trap	Not use SNMP Trap service or Use SNMP Trap service	Specifies whether to use the SNMP trap. If not using the SNMP trap service is specified, SNMP traps cannot be sent to the SNMP manager.
	SNMP Trap Port	Sets the port number to use to connect to the SNMP manager. It is normally not necessary to change this setting.
	Trap 1/2	Sets the SNMP manager destinations for SNMP traps. The SNMP managers can be specified using IP addresses or host names. Community names can also be specified (e.g., public). Either one or two trap destinations can be set.

### 3-11 Communications Test

If the basic settings (in particular the IP address and subnet mask) have been made correctly for the EtherNet/IP Unit or built-in EtherNet/IP port, then it should be possible to communicate with nodes on the EtherNet/IP network. This section describes how to use the PING command to test communications with the EtherNet/IP Unit or built-in EtherNet/IP port.

#### 3-11-1 PING Command

The PING command sends an echo request packet to a remote node and receives an echo response packet to confirm that the remote node is communicating correctly. The PING command uses the ICMP echo request and responses. The echo response packet is automatically returned in the ICMP. The PING command is normally used to check the connections of remote nodes when configuring a network. The EtherNet/IP Unit or built-in EtherNet/IP port supports both the ICMP echo request and reply functions.

If the remote node returns a normal response to the PING command, then the nodes are physically connected correctly and Ethernet node settings are correct.

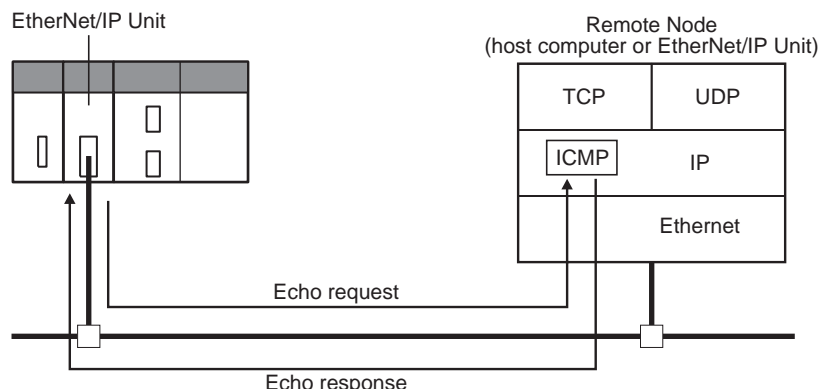

#### 3-11-2 EtherNet/IP Unit or Built-in EtherNet/IP Port Operation

The EtherNet/IP Unit or built-in EtherNet/IP port automatically returns the echo response packet in response to an echo request packet sent by another node (host computer, or other EtherNet/IP Unit or built-in EtherNet/IP port). An echo request packet can be sent to another node by issuing the PING command to execute the PING command from the PLC.

#### 3-11-3 Host Computer Operation

The PING command can be executed from the host computer to send an echo request packet to an EtherNet/IP Unit or built-in EtherNet/IP port. The following example shows how to use the PING command in the host computer.

##### Command Method

Input the following command at the host computer's prompt (\$):  
`$ ping IP_address(host_name)`

The destination is specified by its IP address or host name. If the host name is used, the host name must be defined in the /etc/hosts file.

**Note** The PING command is not supported by some host computers.

## Application Example

In this example, a PING command is sent to the node at IP address 130.25.36.8. The "\$" in the example represents the host computer prompt.

### Normal Execution

```
$ ping 130.25.36.8           ← Executes the PING command.
PING 130.25.36.8: 56 data bytes
64 bytes from 130.25.36.8: icmp_seq=0. time=0. ms
64 bytes from 130.25.36.8: icmp_seq=0. time=0. ms
      :           :           :           :           :
64 bytes from 130.25.36.8: icmp_seq=0. time=0. ms
                                     ← Press the Ctrl+C Keys to cancel execution.
---- 130.25.36.8 PING Statistics ----
9 packets transmitted, 9 packets received, 0% packets loss
round-trip (ms)  min/avg/max  = 0/1/16
$
```

### Error Occurred

```
$ png 130.25.36.8           ← Executes the PING command.
PING 130.25.36.8: 56 data bytes
                                     ← Press the Ctrl+C Keys to cancel execution.
---- 130.25.36.8 PING Statistics ----
9 packets transmitted, 9 packets received, 0% packets loss
$
```

Refer to the OS command reference manual for your computer for details on using the PING command.





# SECTION 4

## Memory Allocations

This section describes the words allocated in the CIO Area and the DM Area for EtherNet/IP Units or built-in EtherNet/IP ports.

4-1	Overview of Memory Allocated to the EtherNet/IP Unit . . . . .	70
4-2	CIO Area Allocations . . . . .	72
4-2-1	Overview of the Allocated CIO Area Words . . . . .	72
4-2-2	Details of the Allocated CIO Area Words . . . . .	73
4-3	DM Area Allocations . . . . .	85
4-3-1	Overview of the Allocated DM Area Words . . . . .	85
4-3-2	Details of the Allocated DM Area Words. . . . .	85
4-4	User Settings Area . . . . .	87
4-4-1	Overview of the User Settings Area . . . . .	87
4-4-2	User Settings Area . . . . .	87
4-5	Auxiliary Area Data . . . . .	90
4-5-1	Read-only Bits/Words. . . . .	90
4-5-2	Read/Write Bits (User Settings). . . . .	91

## 4-1 Overview of Memory Allocated to the EtherNet/IP Unit

The following CPU Unit words are allocated to the EtherNet/IP Unit or built-in EtherNet/IP port.

- CPU Unit's allocated CIO Area words  
Contains software switch and status information.
- CPU Unit's allocated DM Area words  
Contains the IP Address Display/Setting Area
- CPU Unit's user settings area  
Contains status information. (This area can be used only when the allocated CIO Area words are set to user settings.)

**Note** The EtherNet/IP Unit or built-in EtherNet/IP port has the following two data areas in its non-volatile memory. (Unlike the Ethernet Units, settings are not stored in the CPU Unit's CPU Bus Unit System Setup Area.)

- Unit Setup: Settings such as the IP address and FINS/UDP settings. The Unit Setup is set from the CX-Programmer.
- Device parameter settings: Settings such as the tag data link setting parameters. The device parameter settings are made from the Network Configurator.

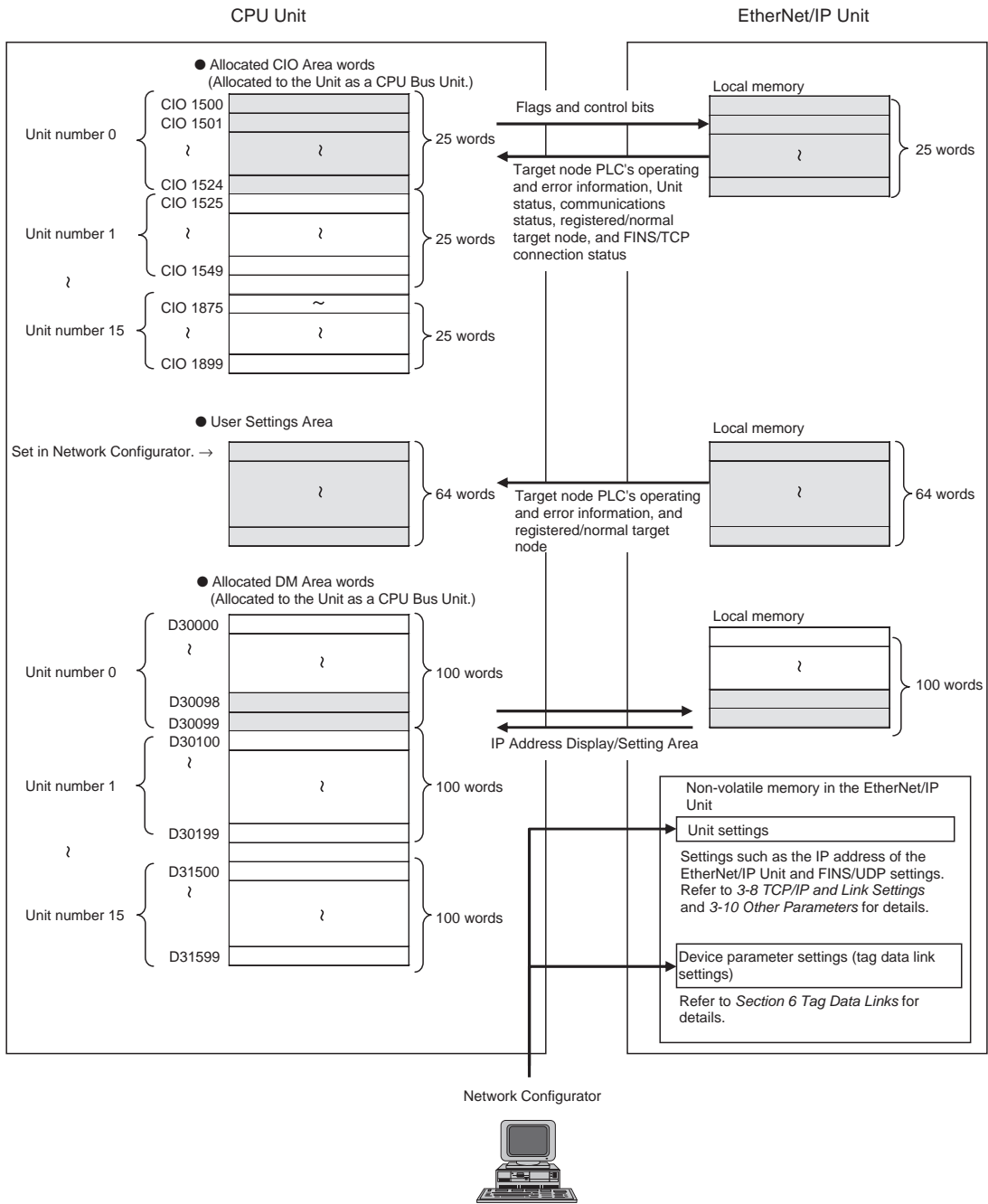

## 4-2 CIO Area Allocations

### 4-2-1 Overview of the Allocated CIO Area Words

The various kinds of data are stored in the allocated CIO Area words, which are identified by the offset from the beginning word (n) allocated to each Unit.

There are two patterns for the layout of the allocated CIO Area words: the default settings and user settings. The layout can be selected in the Status Area settings in the Edit Parameters Dialog Box from the CX-Programmer.

To set a customer areas, select *User defined* for the Layout Type on the Status Area Tab Page.

The beginning word n is calculated by the following equation:

$$\text{Beginning word } n = \text{CIO } 1500 + (25 \times \text{unit number})$$

#### Default Settings

Offset	Bit	15	8 7	0	Data direction
0	n	Unit control bits			CPU Unit → EtherNet/IP Unit
1	n+1	(Reserved)			EtherNet/IP Unit → CPU Unit
2	n+2	Target Node PLC Operating Information (4 words only)			EtherNet/IP Unit → CPU Unit
3	n+3				
4	n+4				
5	n+5				
6	n+6	Target Node PLC Error Information (4 words only)			EtherNet/IP Unit → CPU Unit
7	n+7				
8	n+8				
9	n+9				
10	n+10	Unit status 1			EtherNet/IP Unit → CPU Unit
11	n+11	Unit status 2			
12	n+12	Communications status 1			EtherNet/IP Unit → CPU Unit
13	n+13	Communications status 2			
14	n+14	Communications status 3			
15	n+15	(Reserved)			EtherNet/IP Unit → CPU Unit
16	n+16	Registered Target Node (4 words only)			EtherNet/IP Unit → CPU Unit
17	n+17				
18	n+18				
19	n+19				
20	n+20	Normal Target Node (4 words only)			EtherNet/IP Unit → CPU Unit
21	n+21				
22	n+22				
23	n+23	FINS/TCP Connection Status			EtherNet/IP Unit → CPU Unit
24	n+24				

**Note** The reserved words are regularly refreshed with all zeroes.

User Settings

Offset	Bit		Data direction
0	n	Unit control bits	CPU Unit → EtherNet/IP Unit
1	n+1	(Reserved)	EtherNet/IP Unit → CPU Unit
2	n+2	(Reserved)	
3	n+3		
4	n+4		
5	n+5		
6	n+6		
7	n+7		
8	n+8		
9	n+9		
10	n+10	Unit status 1	EtherNet/IP Unit → CPU Unit
11	n+11	Unit status 2	
12	n+12	Communications status 1	EtherNet/IP Unit → CPU Unit
13	n+13	Communications status 2	
14	n+14	Communications status 3	
15	n+15	(Reserved)	EtherNet/IP Unit → CPU Unit
16	n+16	(Reserved)	
17	n+17		
18	n+18		
19	n+19		
20	n+20		
21	n+21		
22	n+22		
23	n+23		
24	n+24	FINS/TCP Connection Status	EtherNet/IP Unit → CPU Unit

**Note** The reserved words are regularly refreshed with all zeroes.  
 The functions of the allocated CIO Area words are described in the following section.

4-2-2 Details of the Allocated CIO Area Words

Unit Control Bits (CPU Unit to EtherNet/IP Unit) (n)

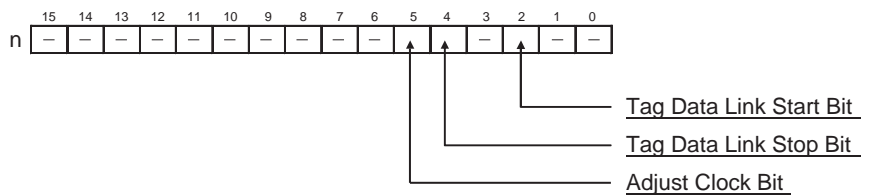

Bit	Switch	Status	Manipulated by	Unit operation
0 to 1	(Not used.)	---	---	---
2	Tag Data Link Start Bit	ON	User	The tag data link starts when this bit is switched from OFF to ON.
		OFF	Unit	Turned OFF by Unit after the tag data link starts operating.

Bit	Switch	Status	Manipulated by	Unit operation
3	(Not used.)	---	---	---
4	Tag Data Link Stop Bit	ON	User	The tag data link stops when this bit is switched from OFF to ON.
		OFF	Unit	Turned OFF by Unit after the tag data link stops operating.
5	Adjust Clock Bit	ON	User	The clock time is automatically adjusted when this bit is switched from OFF to ON.
		OFF	Unit	Turned OFF by Unit after the clock time has been adjusted.
6 to 15	(Not used.)	---	---	---

**Tag Data Link Start Bit (Bit 2)**

Start the tag data links by switching this bit from OFF to ON. If the tag data links are already operating, the signal will be ignored. The tag data link starts operating automatically after the tag data link parameter settings are downloaded from the Network Configurator, the CPU Unit's power is turned ON, or the Unit is restarted.

If the tag data links have been stopped by turning the Tag Data Link Stop Bit (n bit 04) from OFF to ON, the tag data links can be restarted by turning this Tag Data Link Start Bit (n bit 02) from OFF to ON.

Once the tag data links start, the EtherNet/IP Unit automatically turns OFF the Tag Data Link Start Bit. Do not force this bit ON or OFF until it is automatically turned OFF by the Unit.

**Tag Data Link Stop Bit (Bit 4)**

Stop the tag data links by switching this bit from OFF to ON. Once the tag data links have been stopped, they will remain stopped until the Unit is restarted or the Tag Data Link Start Bit is turned ON. (The tag data links will also start operating automatically when the tag data link parameter settings are downloaded from the Network Configurator.)

If the tag data links are already stopped, the signal will be ignored.

Message communications can be performed while the tag data links are stopped.

Once the tag data links have stopped, the EtherNet/IP Unit automatically turns OFF the Tag Data Link Stop Bit. Do not force this bit ON or OFF until it is automatically turned OFF by the Unit.

**Adjust Clock Bit (Bit 5)**

Automatically adjust the time on the clock by switching this bit from OFF to ON. The SNTP server used to adjust the time is set in the Unit Setup.

Once the clock time has been adjusted, the EtherNet/IP Unit automatically turns OFF the Adjust Clock Bit. Do not force this bit ON or OFF until it is automatically turned OFF by the Unit.

**Target Node PLC Operating Information (EtherNet/IP Unit to CPU Unit) (n + 2 to n + 5)**

These words show the operating status of the target node PLCs that are connected with the EtherNet/IP Unit as the originator. This status information is enabled when the PLC status is included in the communications data in both the originator and target node.

These words show the status of nodes 0 to 63 only. If it is necessary to show the status of nodes higher than node 63, select "user settings" as the layout pattern. For details, refer to *4-4 User Settings Area*.

The flags are valid only when the corresponding Normal Target Node Flag is ON. If the corresponding Normal Target Node Flag is OFF, the Target Node PLC Operating Flag indicates the previous operating status.

	15	14	13	12	11	10	9	8	7	6	5	4	3	2	1	0
n+2	15	14	13	12	11	10	9	8	7	6	5	4	3	2	1	0
n+3	31	30	29	28	27	26	25	24	23	22	21	20	19	18	17	16
n+4	47	46	45	44	43	42	41	40	39	38	37	36	35	34	33	32
n+5	63	62	61	60	59	58	57	56	55	54	53	52	51	50	49	48

Bit	Name	Status	Manipulated by	Unit operation
---	Target Node PLC Operating Flags	ON	Unit	The corresponding PLC is operating. (The program is being executed.)
		OFF	Unit	The PLC is not operating.

**Target Node PLC Error Information (EtherNet/IP Unit to CPU Unit) (n + 6 to n + 9)**

These words show the error status (logical OR of fatal and non-fatal errors) of the target node PLCs that are connected with the EtherNet/IP Unit as the originator. This status information is enabled when the PLC status is included in the communications data in both the originator and target node.

These words show the error status of nodes 0 to 63 only. If it is necessary to show the error status of nodes higher than node 63, select “user settings” as the layout pattern. For details, refer to *4-4 User Settings Area*.

The flags are valid only when the corresponding Normal Target Node Flag is ON. If the corresponding Normal Target Node Flag is OFF, the Target Node PLC Error Flag indicates the previous error status.

	15	14	13	12	11	10	9	8	7	6	5	4	3	2	1	0
n+6	15	14	13	12	11	10	9	8	7	6	5	4	3	2	1	0
n+7	31	30	29	28	27	26	25	24	23	22	21	20	19	18	17	16
n+8	47	46	45	44	43	42	41	40	39	38	37	36	35	34	33	32
n+9	63	62	61	60	59	58	57	56	55	54	53	52	51	50	49	48

Bit	Name	Status	Manipulated by	Unit operation
---	Target Node PLC Error Flags	ON	Unit	A fatal or non-fatal error occurred in the corresponding PLC.
		OFF	Unit	No error occurred in the PLC.

**Unit Status 1 (EtherNet/IP Unit to CPU Unit) (n + 10)**

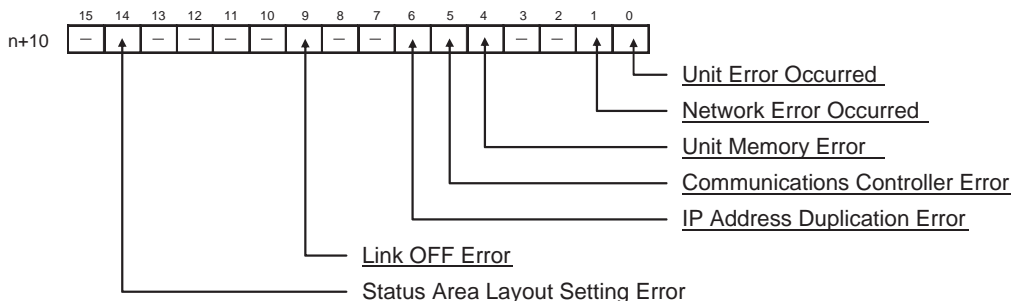

Bit	Name	Status	Manipulated by	Unit operation
0	Unit Error Occurred	ON	Unit	Indicates that an error occurred that is related to EtherNet/IP Unit operation. This flag is turned ON when any bit in Unit Status 1 is ON. (Bits 1 to 15 are logically ORed.)
		OFF	Unit	Indicates that a Unit error did not occur. This flag is turned OFF when the error is cleared.
1	Network Error Occurred	ON	Unit	One or more network-related errors occurred. (The bits in Communications Status 1 and 3 are logically ORed.)
		OFF	Unit	Indicates that a network error did not occur. This flag is turned OFF when the error is cleared.
2 to 3	(Not used)	---	---	---
4	Unit Memory Error	ON	Unit	Indicates that an error occurred in accessing the Unit's internal non-volatile memory (device error).
		OFF	Unit	Indicates that a non-volatile memory error did not occur. This flag is not cleared even if it occurs one time. (Flag remains ON.)
5	Communications Controller Error	ON	Unit	Indicates that an error occurred in the communications controller.
		OFF	Unit	Indicates that a communications controller error did not occur. This flag remains ON until the power supply is turned OFF and ON again.
6	IP Address Duplication Error	ON	Unit	An ARP was sent with the specified IP address, indicating that an IP address duplication was detected. An address duplication is detected if there is an ARP response. This flag remains ON until the power supply is turned OFF and ON again. (The Ethernet interface will stop.)
		OFF	Unit	There was no ARP response.
7 to 8	(Not used)	---	---	---
9	Link OFF Error	ON	Unit	There was an error establishing a link with the switching hub.
		OFF	Unit	A link was established normally with the switching hub.



Bit	Name	Status	Manipulated by	Unit operation
10 to 13	(Not used)	---	---	---
14	Status Area Layout Setting Error	ON	Unit	Indicates that there was an error in the allocated CIO Area's layout settings. When this error occurs, the allocated CIO Area layout is set to the default pattern.  In the following cases, however, the allocated CIO Area layout is set to the user-set pattern. In this case, the user-set area will not be refreshed.  • A non-existent area has been specified.
		OFF	Unit	There was not an error in the layout settings.
15	(Not used)	---	---	---

**Unit Status 2**  
**(EtherNet/IP Unit to**  
**CPU Unit) (n + 11)**

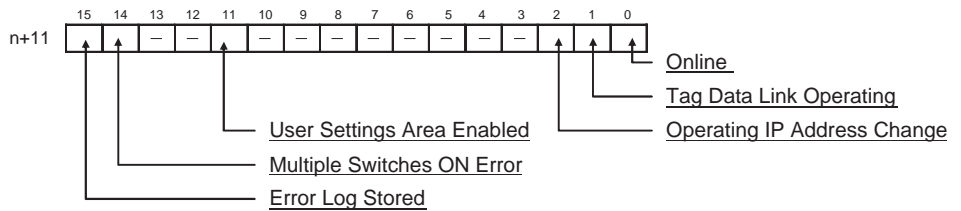

Bit	Name	Status	Manipulated by	Unit operation
0	Online	ON	Unit	Indicates that the Unit is online. (The EtherNet/IP Unit can perform communications processing.)
		OFF	Unit	Indicates that the Unit is not online. This bit is turned OFF in the following cases.  • IP Address Duplication Error • Ethernet Communications Controller Error (hardware error) • BOOTP Server Error

Bit	Name	Status	Manipulated by	Unit operation
1	Tag Data Link Operating	ON	Unit	Indicates that the tag data link is operating. Turned OFF when communications stop in the following cases. <ul style="list-style-type: none"> <li>• Hardware error</li> <li>• IP Address Duplication Error</li> <li>• BOOTP Server Error</li> <li>• Basic Ethernet Settings Error</li> <li>• Memory Error (MAC Address Error)</li> </ul>
		OFF	Unit	Indicates that the tag data link is stopped. Turned ON in the following cases. <ul style="list-style-type: none"> <li>• The Unit is set as the originator and the power supply was turned ON or the Unit was restarted.</li> <li>• The Unit is set as the originator and the Tag Data Link Start Bit was turned ON.</li> </ul>
2	Operating IP Address Change	ON	Unit	ON if the node address setting is different from the setting when the power was turned ON.
		OFF	Unit	OFF if the node address setting is the same as the setting when the power was turned ON.
3 to 10	(Not used)	---	---	---
11	User Setting Area Enabled	ON	Unit	Indicates that the user settings area data is enabled. ON when "user settings" have been specified as the layout of the allocated CIO Area, and refreshing of the user settings area has started.
		OFF	Unit	Indicates that the user settings area data is invalid. The bit is turned OFF in the following cases, because communications stop. <ul style="list-style-type: none"> <li>• The allocated CIO Area layout is set to default settings.</li> <li>• The allocated CIO Area layout is set to user settings, but one of the following problems occurred. <ul style="list-style-type: none"> <li>• A Layout Setting Error occurred.</li> </ul> </li> </ul>
12 to 13	(Not used)	---	---	---
14	Multiple Switches ON Error	ON	Unit	ON when two or more control bits are ON simultaneously. (Unused bits are ignored.)
		OFF	Unit	Turned OFF when the next control bit operation starts.

Bit	Name	Status	Manipulated by	Unit operation
15	Error Log Stored	ON	Unit	Indicates that an error record is registered in the error log.
		OFF	Unit	Indicates that no error records are registered in the error log. Also turned OFF when an error log clear request is received.

**Communications  
Status 1  
(EtherNet/IP Unit to  
CPU Unit) (n + 12)**

Word n+12 contains status flags related to the tag data links, as shown in the following diagram.

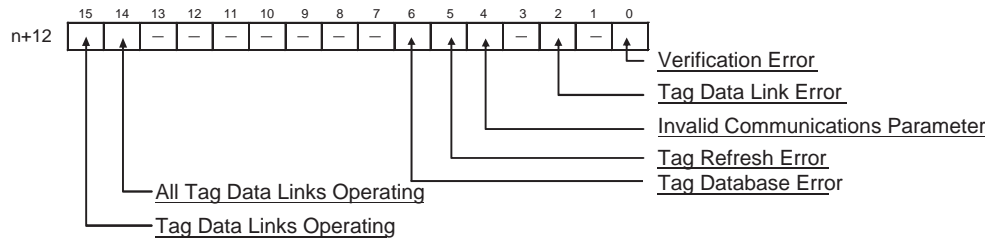

Bit	Name	Status	Manipulated by	Unit operation
0	Verification Error	ON	Unit	Indicates that the information registered for a target node in the tag data link parameters is different from the actual node information.  Main causes: <ul style="list-style-type: none"> <li>• The specified target does not exist.</li> <li>• The variable name does not match.</li> <li>• The connection size is different.</li> <li>• Connection resources are insufficient.</li> </ul>
		OFF	Unit	Indicates that a verification error has not occurred. Also turned OFF when a verification error is cleared.
1	(Not used)	---	---	---
2	Tag Data Link Error	ON	Unit	Indicates that there were two or more errors in a connection as an originator.  This status does not indicate the following errors. <ul style="list-style-type: none"> <li>• Connection as a target</li> <li>• Connection timeout due to a Link OFF Error with the switching hub</li> </ul>
		OFF	Unit	Indicates that the errors listed above did not occur.
3	(Not used)	---	---	---

Bit	Name	Status	Manipulated by	Unit operation
4	Invalid Communications Parameter	ON	Unit	ON when there was an error in the validation check of tag data link parameters stored in the Unit's non-volatile memory, and a checksum error occurred. (Includes parameters related to basic Ethernet settings.) The tag data links will stop.
		OFF	Unit	OFF when the validation check of parameters in non-volatile memory was normal.
5	Tag Refresh Error	ON	Unit	ON when a specified data area or address range is not supported in tag data links.
		OFF	Unit	OFF when the specified data areas and addresses are supported in tag data links.
6	Tag Database Error	ON	Unit	ON if a tag database error occurs in the CPU Unit when a symbol name is used incorrectly in a setting for the EtherNet/IP Unit or built-in EtherNet/IP port (tag data link, status area allocations setting, etc.). (CJ2H-CPU6□-EIP or CJ2M-CPU3□ only)
		OFF	Unit	OFF when a symbol name is not used in a setting for the EtherNet/IP Unit or built-in EtherNet/IP port, when a tag database error has not occurred, or when a previous error has been cleared.
7 to 13	(Not used)	---	---	---
14	All Tag Data Links Operating	ON	Unit	Indicates that tag data links are communicating in all connections as the originator.
		OFF	Unit	Indicates that a tag data link failed in on or more connections as the originator. (OFF even if some tag data links are communicating.)
15	Tag Data Links Operating	ON	Unit	Indicates that tag data links are communicating in one or more connections as the originator.
		OFF	Unit	Indicates that not even one tag data link is communicating in connections as the originator. (OFF even if the Unit is communicating as a target.)

**Communications  
Status 2  
(EtherNet/IP Unit to  
CPU Unit) (n + 13)**

Word n+13 contains status flags related to the Ethernet, as shown in the following diagram.

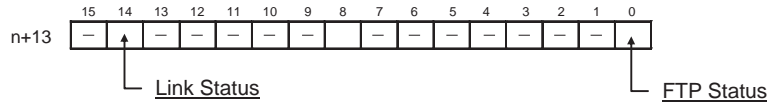

Bit	Name	Status	Manipulated by	Unit operation
0	FTP Status	ON	Unit	ON when the FTP server is operating (i.e., when there is an FTP client connection).
		OFF	Unit	OFF when the FTP is on standby (i.e., waiting for a client connection).
1 to 13	(Not used)	---	---	---
14	Link Status	ON	Unit	ON when a link is established with the switching hub.
		OFF	Unit	OFF when the link with the switching hub is stopped.
15	(Not used)	---	---	---

**Communications  
Status 3  
(EtherNet/IP Unit to  
CPU Unit) (n + 14)**

Word n+14 contains status flags related to the Ethernet errors, as shown in the following diagram.

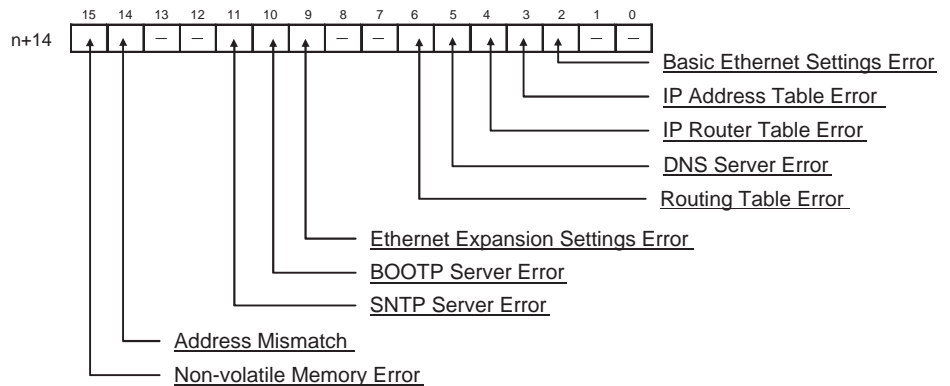

Bit	Name	Status	Manipulated by	Unit operation
0 to 1	(Not used)	---	---	---
2	Basic Ethernet Settings Error	ON	Unit	One of the following parameters is invalid. • TCP/IP Configuration settings (IP address, subnet mask, or Link settings)
		OFF	Unit	OFF when the parameters above are valid.
3	IP Address Table Error	ON	Unit	ON when the IP address table information is incorrect.
		OFF	Unit	OFF when the IP address table information is correct.

Bit	Name	Status	Manipulated by	Unit operation
4	IP Router Table Error	ON	Unit	ON when the IP router table information is incorrect.
		OFF	Unit	OFF when the IP router table information is correct.
5	DNS Server Error	ON	Unit	One of the following errors occurred when using the DNS server. <ul style="list-style-type: none"> <li>• An illegal server IP address is set.</li> <li>• A communications timeout occurred with the server.</li> </ul>
		OFF	Unit	OFF when the IP router table information is correct.
6	Routing Table Error	ON	Unit	ON when the routing table information is incorrect.
		OFF	Unit	OFF when the routing table information is correct.
7 to 8	(Not used)	---	---	---
9	Ethernet Expansion Settings Error	ON	Unit	One of the following parameters is invalid. <ul style="list-style-type: none"> <li>• FINS settings</li> </ul>
		OFF	Unit	OFF when the parameters above are valid.
10	BOOTP Server Error	ON	Unit	One of the following errors occurred when using the BOOTP server. <ul style="list-style-type: none"> <li>• The IP address received from the BOOTP server is incorrect.</li> <li>• A communications timeout occurred with the server.</li> </ul>
		OFF	Unit	OFF when the errors listed above did not occur.
11	SNTP Server Error	ON	Unit	One of the following errors occurred when using the SNTP server. <ul style="list-style-type: none"> <li>• An illegal server IP address or host name is set.</li> <li>• A communications timeout occurred with the server.</li> </ul>
		OFF	Unit	OFF when the errors listed above did not occur.
12 to 13	(Not used)	---	---	---
14	Address Mismatch	ON	Unit	ON when the target IP address conversion method is set to <i>Automatic generation</i> , but the local IP address' host ID does not match the FINS node address.
		OFF	Unit	OFF when the values match.
15	Non-volatile Memory Error	ON	Unit	ON when an error occurred in the Unit's internal non-volatile memory.
		OFF	Unit	OFF when the Unit's internal non-volatile memory is operating normally.

**Registered Target Node Table (EtherNet/IP Unit to CPU Unit) (n + 16 to n + 19)**

Words n+16 to n+19 show the registration status of the target nodes that are connected with the EtherNet/IP Unit as the originator.

These words show the status of nodes 0 to 63 only. If it is necessary to show the status of nodes higher than node 63, select "user settings" as the layout pattern. For details, refer to 4-4 User Settings Area.

	15	14	13	12	11	10	9	8	7	6	5	4	3	2	1	0
n+16	15	14	13	12	11	10	9	8	7	6	5	4	3	2	1	0
n+17	31	30	29	28	27	26	25	24	23	22	21	20	19	18	17	16
n+18	47	46	45	44	43	42	41	40	39	38	37	36	35	34	33	32
n+19	63	62	61	60	59	58	57	56	55	54	53	52	51	50	49	48

Bit	Name	Status	Manipulated by	Unit operation
---	Registered Target Node Flags	ON	Unit	Indicates that the node's tag data link is registered.
		OFF	Unit	Indicates that the node's tag data link is not registered.

**Normal Target Node Table (EtherNet/IP Unit to CPU Unit) (n+20 to n+23)**

Words n+20 to n+23 show the connection status of the target nodes that are connected with the EtherNet/IP Unit as the originator. With revision 2 or higher, the flag turns ON after all data for multiple connections for individual target devices is refreshed in the CPU Unit. With revision 1, each flag immediately turns ON when all connections are established.

These words show the status of nodes 0 to 63 only. If it is necessary to show the status of nodes higher than node 63, select "user settings" as the layout pattern. For details, refer to 4-4 User Settings Area.

	15	14	13	12	11	10	9	8	7	6	5	4	3	2	1	0
n+20	15	14	13	12	11	10	9	8	7	6	5	4	3	2	1	0
n+21	31	30	29	28	27	26	25	24	23	22	21	20	19	18	17	16
n+22	47	46	45	44	43	42	41	40	39	38	37	36	35	34	33	32
n+23	63	62	61	60	59	58	57	56	55	54	53	52	51	50	49	48

Bit	Name	Status	Manipulated by	Unit operation
---	Normal Target Node Flags	ON	Unit	Revision 1: Flags immediately turn ON when all connections are established. Revision 2 or higher: Flags turn ON after all data for multiple connections for the target device is refreshed in the CPU Unit.
		OFF	Unit	Indicates that the connection is not established

**FINS/TCP Connection Status (EtherNet/IP Unit to CPU Unit) (n+24)**

Word n+24 shows the status of FINS/TCP connections. For details, refer to SECTION 8 FINS Communications.

	15	14	13	12	11	10	9	8	7	6	5	4	3	2	1	0
n+24																

Bit	Name	Status	Manipulated by	Unit operation
0	FINS/TCP Connection 1	ON	Unit	Turned ON by the Unit when a connection is established.
		OFF	Unit	Turned OFF by the Unit when the connection is terminated.

<b>Bit</b>	<b>Name</b>	<b>Status</b>	<b>Manipulated by</b>	<b>Unit operation</b>
1	FINS/TCP Connection 2	ON	Unit	Turned ON by the Unit when a connection is established.
		OFF	Unit	Turned OFF by the Unit when the connection is terminated.
:	:	:	:	:
14	FINS/TCP Connection 15	ON	Unit	Turned ON by the Unit when a connection is established.
		OFF	Unit	Turned OFF by the Unit when the connection is terminated.
15	FINS/TCP Connection 16	ON	Unit	Turned ON by the Unit when a connection is established.
		OFF	Unit	Turned OFF by the Unit when the connection is terminated.



### 4-3 DM Area Allocations

#### 4-3-1 Overview of the Allocated DM Area Words

The various kinds of data are stored in the offset positions shown in the following diagram, from the beginning word in the area for each Unit.

The beginning word m is calculated by the following equation:

$$\text{Beginning word } m = D30000 + (100 \times \text{unit number})$$

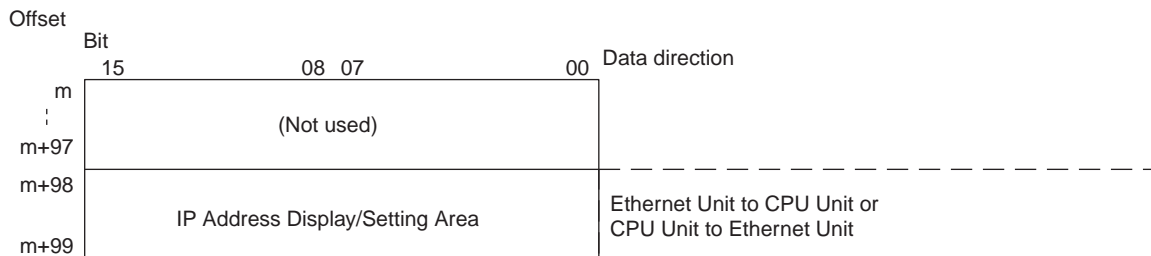

#### 4-3-2 Details of the Allocated DM Area Words

##### IP Address Display/Setting Area (m+98 and m+99)

	15	14	13	12	11	10	9	8	7	6	5	4	3	2	1	0
m+98	(1)				(2)				(3)				(4)			
m+99	(5)				(6)				(7)				(8)			

(1)(2).(3)(4).(5)(6).(7)(8) (Hex)

IP address: (1)(2).(3)(4).(5)(6).(7)(8) (Hex)

If the local IP address is set to a value other than 0.0.0.0 in the TCP/IP Configuration, this area (words m+98 and m+99) will act as an IP Address Display Area and the local IP address set in the TCP/IP Configuration will be read and stored here when the power is turned ON or the Unit restarted.

If the local IP address in the TCP/IP Configuration is set to 0.0.0.0, this value is read by the EtherNet/IP Unit when the power is turned ON or the Unit restarted and is used as the local IP address.

If the local IP address in these words and the TCP/IP Configuration are both set to 0.0.0.0, the default IP address (192.168.250.Node\_address) will be used. For details on the IP address settings, refer to SECTION 5 Determining IP Addresses.

Application	Setting device	Setting area	Remarks
Simple operation (i.e., The TCP/IP Configuration is left at its default settings. Only the IP address is set.)	Programming Console (CX-Programmer can also be used.)	Allocated words in the DM Area	<ul style="list-style-type: none"> <li>The setting in the allocated DM Area words is enabled only when the IP address is set to 0.0.0.0 in the TCP/IP Configuration.</li> <li>If the IP address is set to a value other than 00.00.00.00 in the TCP/IP Configuration, this value is stored in the allocated words in the DM Area.</li> </ul>
Operation with the desired IP address set in the TCP/IP Configuration.	CX-Programmer (Unit Setup)	Setup TCP/IP Configuration Dialog Box	The IP address set in the Setup TCP/IP Configuration Dialog Box is stored in the allocated DM Area words.

**Note** (1) If an IP address other than 00.00.00.00 is set as the local IP address in the TCP/IP Configuration, the IP Address Display/Setting Area words (m+98 and m+99) will be overwritten with the TCP/IP Configuration's IP

address, even if a non-zero IP address was set in the IP Address Display/Setting Area words beforehand.

- (2) It is not possible to set the following IP addresses. If any of these values are set, the ERH indicator will flash.
- IP addresses where all network number bits are 0 or 1.
  - IP addresses where all host number bits are 0 or 1.
  - IP addresses where all subnet number bits are 1.
  - IP addresses that start with 127 (7F hexadecimal, e.g., 127.35.21.16).

## 4-4 User Settings Area

### 4-4-1 Overview of the User Settings Area

When the layout of the allocated CIO Area words is set to user settings, the user settings area can be used in addition to the allocated CIO Area words and allocated DM Area words.

The beginning word of the user settings area can be set in the Status Area Tab Page in the Edit Parameters Dialog Box of the CX-Programmer.

### 4-4-2 User Settings Area

The user can allocate any available area to contain the registered target node information, normal target node information, target node PLC operating information, and target node PLC error information.

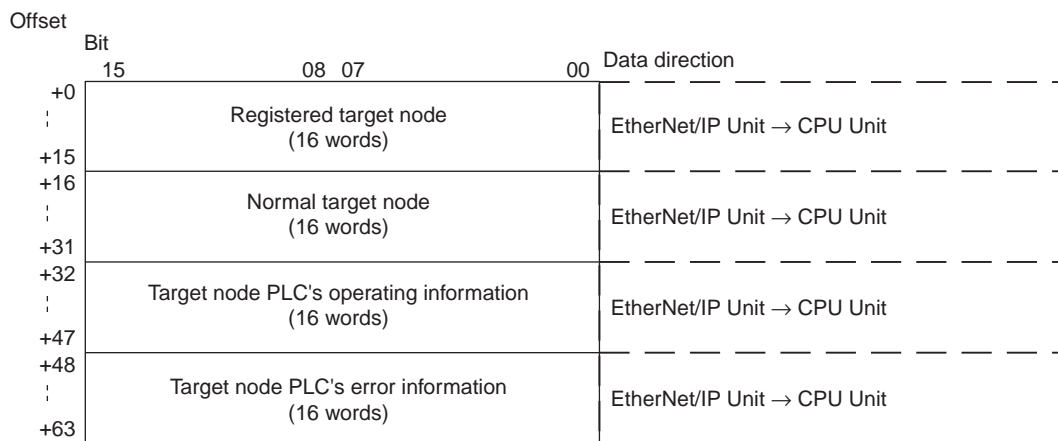

### Registered Target Node Table (EtherNet/IP Unit to CPU Unit)

These flags indicate the registration status of the target nodes, and are valid only when the EtherNet/IP Unit is the originator of the connection. For details on the default settings, refer to 4-2-2 *Details of the Allocated CIO Area Words*.

	15	14	13	12	11	10	9	8	7	6	5	4	3	2	1	0
+0	15	14	13	12	11	10	9	8	7	6	5	4	3	2	1	0
+1	31	30	29	28	27	26	25	24	23	22	21	20	19	18	17	16
+2	47	46	45	44	43	42	41	40	39	38	37	36	35	34	33	32
+3	63	62	61	60	59	58	57	56	55	54	53	52	51	50	49	48
+4	79	78	77	76	75	74	73	72	71	70	69	68	67	66	65	64
+5	95	94	93	92	91	90	89	88	87	86	85	84	83	82	81	80
+6	111	110	109	108	107	106	105	104	103	102	101	100	99	98	97	96
+7	127	126	125	124	123	122	121	120	119	118	117	116	115	114	113	112
+8	143	142	141	140	139	138	137	136	135	134	133	132	131	130	129	128
+9	159	158	157	156	155	154	153	152	151	150	149	148	147	146	145	144
+10	175	174	173	172	171	170	169	168	167	166	165	164	163	162	161	160
+11	191	190	189	188	187	186	185	184	183	182	181	180	179	178	177	176
+12	207	206	205	204	203	202	201	200	199	198	197	196	195	194	193	192
+13	223	222	221	220	219	218	217	216	215	214	213	212	211	210	209	208
+14	239	238	237	236	235	234	233	232	231	230	229	228	227	226	225	224
+15	255	254	253	252	251	250	249	248	247	246	245	244	243	242	241	240

Bit	Name	Status	Manipulated by	Unit operation
---	Registered Target Node Flags	ON	Unit	Indicates that the node's tag data link is registered.
		OFF	Unit	Indicates that the node's tag data link is not registered.

**Normal Target Node Table (EtherNet/IP Unit to CPU Unit)**

These flags indicate the connection status of the target nodes. With revision 2 or higher, the flag turns ON after all data for multiple connections for individual target devices is refreshed in the CPU Unit. With revision 1, each flag immediately turns ON when all connections are established.

	15	14	13	12	11	10	9	8	7	6	5	4	3	2	1	0
+16	15	14	13	12	11	10	9	8	7	6	5	4	3	2	1	0
+17	31	30	29	28	27	26	25	24	23	22	21	20	19	18	17	16
+18	47	46	45	44	43	42	41	40	39	38	37	36	35	34	33	32
+19	63	62	61	60	59	58	57	56	55	54	53	52	51	50	49	48
+20	79	78	77	76	75	74	73	72	71	70	69	68	67	66	65	64
+21	95	94	93	92	91	90	89	88	87	86	85	84	83	82	81	80
+22	111	110	109	108	107	106	105	104	103	102	101	100	99	98	97	96
+23	127	126	125	124	123	122	121	120	119	118	117	116	115	114	113	112
+24	143	142	141	140	139	138	137	136	135	134	133	132	131	130	129	128
+25	159	158	157	156	155	154	153	152	151	150	149	148	147	146	145	144
+26	175	174	173	172	171	170	169	168	167	166	165	164	163	162	161	160
+27	191	190	189	188	187	186	185	184	183	182	181	180	179	178	177	176
+28	207	206	205	204	203	202	201	200	199	198	197	196	195	194	193	192
+29	223	222	221	220	219	218	217	216	215	214	213	212	211	210	209	208
+30	239	238	237	236	235	234	233	232	231	230	229	228	227	226	225	224
+31	255	254	253	252	251	250	249	248	247	246	245	244	243	242	241	240

Bit	Name	Status	Manipulated by	Unit operation
---	Normal Target Node Flags	ON	Unit	Revision 1: Flags immediately turn ON when all connections are established. Revision 2 or higher: Flags turn ON after all data for multiple connections for the target device is refreshed in the CPU Unit.
		OFF	Unit	Indicates that all connections are not established

**Target Node PLC Operating Information (EtherNet/IP Unit to CPU Unit)**

These flags indicate the operating status of the target node PLCs, and are valid only when the EtherNet/IP Unit is the originator. The flags are valid only when the corresponding Normal Target Node Flag is ON. If the corresponding Normal Target Node Flag is OFF, the Target Node PLC Operating Flag indicates the previous operating status.

For details on the default settings, refer to 4-2-2 *Details of the Allocated CIO Area Words*.

	15	14	13	12	11	10	9	8	7	6	5	4	3	2	1	0
+32	15	14	13	12	11	10	9	8	7	6	5	4	3	2	1	0
+33	31	30	29	28	27	26	25	24	23	22	21	20	19	18	17	16
+34	47	46	45	44	43	42	41	40	39	38	37	36	35	34	33	32
+35	63	62	61	60	59	58	57	56	55	54	53	52	51	50	49	48
+36	79	78	77	76	75	74	73	72	71	70	69	68	67	66	65	64
+37	95	94	93	92	91	90	89	88	87	86	85	84	83	82	81	80
+38	111	110	109	108	107	106	105	104	103	102	101	100	99	98	97	96
+39	127	126	125	124	123	122	121	120	119	118	117	116	115	114	113	112
+40	143	142	141	140	139	138	137	136	135	134	133	132	131	130	129	128
+41	159	158	157	156	155	154	153	152	151	150	149	148	147	146	145	144
+42	175	174	173	172	171	170	169	168	167	166	165	164	163	162	161	160
+43	191	190	189	188	187	186	185	184	183	182	181	180	179	178	177	176
+44	207	206	205	204	203	202	201	200	199	198	197	196	195	194	193	192
+45	223	222	221	220	219	218	217	216	215	214	213	212	211	210	209	208
+46	239	238	237	236	235	234	233	232	231	230	229	228	227	226	225	224
+47	255	254	253	252	251	250	249	248	247	246	245	244	243	242	241	240

Bit	Name	Status	Manipulated by	Unit operation
---	Target Node PLC Operating Flags	ON	Unit	The corresponding PLC is operating. (The program is being executed.)
		OFF	Unit	The PLC is not operating.

**Target Node PLC Error Information (EtherNet/IP Unit to CPU Unit)**

These flags indicate the error status (logical OR of fatal and non-fatal errors) of the target node PLCs, and are valid only when the EtherNet/IP Unit is the originator. The flags are valid only when the corresponding Normal Target Node Flag is ON. If the corresponding Normal Target Node Flag is OFF, the Target Node PLC Error Flag indicates the previous error status.

For details on the default settings, refer to 4-2-2 *Details of the Allocated CIO Area Words*.

	15	14	13	12	11	10	9	8	7	6	5	4	3	2	1	0
+48	15	14	13	12	11	10	9	8	7	6	5	4	3	2	1	0
+49	31	30	29	28	27	26	25	24	23	22	21	20	19	18	17	16
+50	47	46	45	44	43	42	41	40	39	38	37	36	35	34	33	32
+51	63	62	61	60	59	58	57	56	55	54	53	52	51	50	49	48
+52	79	78	77	76	75	74	73	72	71	70	69	68	67	66	65	64
+53	95	94	93	92	91	90	89	88	87	86	85	84	83	82	81	80
+54	111	110	109	108	107	106	105	104	103	102	101	100	99	98	97	96
+55	127	126	125	124	123	122	121	120	119	118	117	116	115	114	113	112
+56	143	142	141	140	139	138	137	136	135	134	133	132	131	130	129	128
+57	159	158	157	156	155	154	153	152	151	150	149	148	147	146	145	144
+58	175	174	173	172	171	170	169	168	167	166	165	164	163	162	161	160
+59	191	190	189	188	187	186	185	184	183	182	181	180	179	178	177	176
+60	207	206	205	204	203	202	201	200	199	198	197	196	195	194	193	192
+61	223	222	221	220	219	218	217	216	215	214	213	212	211	210	209	208
+62	239	238	237	236	235	234	233	232	231	230	229	228	227	226	225	224
+63	255	254	253	252	251	250	249	248	247	246	245	244	243	242	241	240

Bit	Name	Status	Manipulated by	Unit operation
---	Target Node PLC Error Flags	ON	Unit	A fatal or non-fatal error occurred in the corresponding PLC.
		OFF	Unit	No error occurred in the PLC.

## 4-5 Auxiliary Area Data

The following table and descriptions cover the words and bits in the CPU Unit's Auxiliary Area that are related to the EtherNet/IP Unit.

### 4-5-1 Read-only Bits/Words

Word(s)	Bit(s)	Name	Function	Settings
A202	A20200 to A20207	Communications Port Enabled Flags	Bits A20200 to A20207 turn ON when a network instruction (SEND, RECV, CMND, or PMCR) can be executed with the corresponding port number. Bits 00 to 07 correspond to communications ports 0 to 7.	0: Network communications running 1: No network communications running
A203 to A210	---	Communications Port Completion Codes	These words contain the completion codes for the corresponding port numbers when network instructions (SEND, RECV, CMND, or PMCR) have been executed. Words A203 to A210 correspond to communications ports 0 to 7.	0000: No error Not 0000: Error code
A219	A21900 to A21907	Communications Port Error Flags	Bits A21900 to A21907 turn ON when an error occurred during execution of a network instruction (SEND, RECV, CMND, or PMCR). Bits 00 to 07 correspond to communications ports 0 to 7.	0: Normal end 1: Error end
A302	A30200 to A30215	CPU Bus Unit Initializing Flags	Bits A30200 through A30215 turn ON while the corresponding CPU Bus Units (Units #0 through #15, respectively) are initializing. The bits will turn ON either when power is turned ON or when a CPU Bus Unit Restart Bit (A50100 to A50115) is turned ON.	0: Not initializing 1: Initializing (System will automatically turn the flag OFF when initialization has been completed.)
A402	A40203	CPU Bus Unit Setting Error Flag (Non-fatal error)	Bit A40203 is turned ON when the CPU Bus Units actually installed differ from the Units registered in the I/O tables. The ERR/ALM indicator on the front of the CPU Unit will flash, but CPU operation will continue.  The unit number of the CPU Bus Unit involved is stored in word A427.	0: No setting error 1: Setting error
	A40207	CPU Bus Unit Error Flag (Non-fatal error)	Bit A40207 is turned ON when an error occurs during the transmission of data between the CPU and CPU Bus Units. The ERR/ALM indicator on the front of the CPU Unit will flash, but CPU operation will continue. The Unit where the error occurred will stop.  The unit number of the CPU Bus Unit involved is stored in word A422.	0: No unit number error 1: Unit number error
A403	A40300 to A40308	Memory Error Location	When a memory error occurs, the Memory Error Flag (A40115) is turned ON and one of the following flags is turned ON to indicate the memory area where the error occurred.  A40300: User program A40304: PLC Setup A40305: Registered I/O Tables A40307: Routing Tables  The ERR/ALM indicator on the front of the CPU Unit will light and CPU operation will stop.	0: Normal 1: Error
A410	A41000 to A41015	CPU Bus Unit Number Duplication Flags	The Duplication Error Flag (A40113) and the corresponding flag in A410 will be turned ON when a CPU Bus Unit's unit number has been duplicated. Bits 00 to 15 correspond to unit numbers 0 to F.  The ERR/ALM indicator on the front of the CPU Unit will light and CPU operation will stop.	0: No duplication 1: Duplication

Word(s)	Bit(s)	Name	Function	Settings
A417	A41700 to A41715	CPU Bus Unit Error, Unit Number Flags	When an error occurs in a data exchange between the CPU Unit and a CPU Bus Unit, the CPU Bus Unit Error Flag (A40207) and the corresponding flag in A417 are turned ON. Bits 00 to 15 correspond to unit numbers 0 to F.  The ERR/ALM indicator on the front of the CPU Unit will flash, but CPU operation will continue.	0: No error 1: Error
A427	A42700 to A42715	CPU Bus Unit Setting Error, Unit Number Flags	When a CPU Bus Unit Setting Error occurs, A40203 and the corresponding flag in A27 are turned ON. Bits 00 to 15 correspond to unit numbers 0 to F.  The ERR/ALM indicator on the front of the CPU Unit will flash, but CPU operation will continue.	0: No setting error 1: Setting error

### 4-5-2 Read/Write Bits (User Settings)

Word	Bits	Name	Description	Settings
A501	A50100 to A50115	CPU Bus Unit Restart Bits	Bits A50100 through A50115 can be turned ON to reset CPU Bus Units number #0 through #15, respectively.  <b>Note</b> The CPU Bus Unit Initializing Flags (A30200 to A30215) will turn ON when initialization of the Units begins and turn OFF when it is completed.  <b>Note</b> When turning ON the CPU Bus Unit Restart Bit from a ladder program, use the SET instruction.	OFF to ON: Unit restarted. Automatically turned OFF by system after restart processing has been completed.





# SECTION 5

## Determining IP Addresses

This section explains how to manage and use IP addresses.

5-1	IP Addresses . . . . .	94
5-1-1	IP Address Configuration . . . . .	94
5-1-2	Allocating IP Addresses . . . . .	94
5-1-3	EtherNet/IP Unit IP Address Settings. . . . .	95
5-1-4	Subnet Masks . . . . .	95
5-1-5	CIDR. . . . .	96
5-2	IP Addresses in FINS Communications . . . . .	96
5-2-1	Specifying Nodes in FINS Communications Services. . . . .	96
5-2-2	Pairing Addresses in Internal Tables . . . . .	98
5-2-3	Application Examples. . . . .	104
5-2-4	Related Products and Communications/Setting Methods. . . . .	105
5-2-5	Pairing IP Addresses and FINS Node Addresses . . . . .	107
5-3	Private and Global Addresses . . . . .	108
5-3-1	Private and Global Addresses . . . . .	108
5-3-2	Using a Private Address for the EtherNet/IP Unit . . . . .	109
5-3-3	EtherNet/IP Unit with a Global Address . . . . .	111

## 5-1 IP Addresses

### 5-1-1 IP Address Configuration

IP addresses are made up of 32 bits of binary data divided into four 8-bit fields called octets. These four octets provide the network number (net ID) and host number (host ID). The network number identifies the network, and the host number identifies the node (or host) on the network.

The network numbers in an IP address are divided into three classes, A, B, and C, so that the address system can be selected according to the scale of the network. (Classes D and E are not used.) The configuration of the IP address for each of these classes is shown in the following diagram.

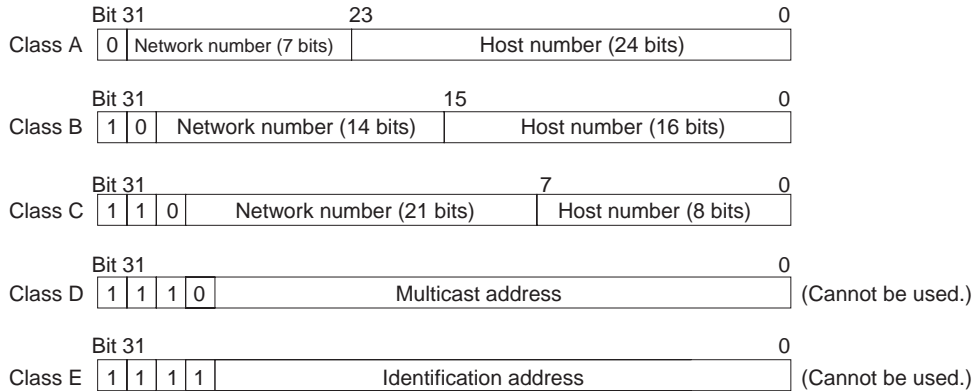

The number of networks in each class and the number of nodes possible on the network differ according to the class.

Class	Number of networks	Number of hosts
Class A	Small	$2^{24}-2$ max. (16,777,214 max.)
Class B	Medium	$2^{16}-2$ max. (65,534 max.)
Class C	Large	$2^8-2$ max. (254 max.)

The 32 bits of an IP address are divided into four sections of eight bits each, and expressed as a punctuated number. IP addresses are represented by the decimal equivalent of each of the four octets in the 32-bit address, each separated by a period. For example, the binary address 10000010 00111010 00010001 00100000 would be represented as 130.58.17.32.

**Note** The same network number must be set for every node on the same Ethernet network.

### 5-1-2 Allocating IP Addresses

IP (Internet Protocol) is a standard communications protocol used throughout the world, and is designed to enable communications between any Ethernet nodes regardless of the networks on which they exist. To achieve this, network numbers are allocated by the Network Solutions, InterNIC Registration Services, to ensure that all Ethernet networks have unique numbers regardless of where they exist. The local system administrator is left the responsibility of allocating unique host numbers locally. You therefore should obtain a network number from the InterNIC Registration Services to ensure uniqueness and allow for future network expansions if required.

### 5-1-3 EtherNet/IP Unit IP Address Settings

An IP address must be set even for the EtherNet/IP Unit or built-in EtherNet/IP port before Ethernet communications can proceed. Use one of the following methods to set the IP address of the EtherNet/IP Unit or built-in EtherNet/IP port. Either use the default IP address setting, use a Programming Device to set a particular IP address in the DM Area words (CS/CJ Series only) allocated to the Unit as a CPU Bus Unit, or set a particular IP address in the EtherNet/IP Unit or built-in EtherNet/IP port.

- If you want to connect the EtherNet/IP Unit or built-in EtherNet/IP port immediately, the default IP address is 192.168.250.Node\_address. (The node address is set with the Node Address Setting Switches on the front of the EtherNet/IP Unit or CPU Unit.)
- If you want to set a particular IP address and store that local IP address in the CPU Unit, set it with the CPU Unit's allocated DM Area words (CS/CJ Series only).
- If you want to set a particular IP address and store that local IP address in the EtherNet/IP Unit or CPU Unit, set the IP address in the TCP/IP settings of the Unit Setup from the CX-Programmer.
- If you want to set a particular IP address and obtain the IP address automatically from the BOOTP server, TCP/IP settings of the Unit Setup from the CX-Programmer. For details, refer to 3-8 TCP/IP and Link Settings.

### 5-1-4 Subnet Masks

Operation and management of a network can become very difficult if too many nodes are connected on a single network. In such a case it can be helpful to configure the system so that a single network is divided up into several subnetworks. This can be done by using part of the host number as a subnet number. Internally the network can be treated as a number of subnetworks, but from the outside it acts as a single network and uses only a single Network ID.

To establish subnetworks, the Host ID in the IP address is divided into a Subnet ID and a Host ID by using a setting called the Subnet Mask. The Subnet Mask indicates which part of the Host ID is to be used as the Subnet ID. All bits in the Subnet Mask that correspond to the bits in the IP address used either as the Network ID or Subnet ID are set to "1," and the remaining bits, which correspond to the bits in the IP address actually used for the Host ID, are set to "0."

The following example shows the Subnet Mask for an 8-bit Subnet ID used in a class-B IP address.

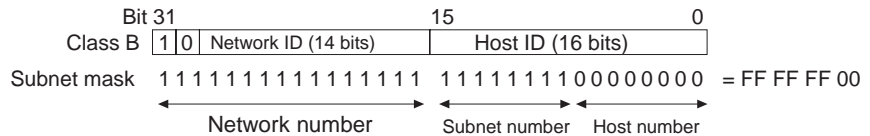

Set the same Subnet Mask value for all of the nodes on that subnetwork. If no subnetworks are used, there is no need to set Subnet Masks. In that case, the following Subnet Mask values will be used depending on the IP address class.

Class	Subnet Mask value
Class A	255.0.0.0
Class B	255.255.0.0
Class C	255.255.255.0

### 5-1-5 CIDR

CIDR, or classless interdomain routing, is used to assign IP addresses that do not use classes. IP addresses that use classes are separated into blocks according to net IDs and host IDs, resulting in inefficient usage of IP address space.

CIDR does not use classes, so IP address space can be divided as required to more efficiently use IP address space. For example, using a subnet mask setting with CIDR enables building a horizontally distributed network exceeding 254 nodes even if a class C address block (e.g., 192, 168...).

Subnet mask range
192.0.0.0 to 255.255.255.252

CIDR was added for unit version 2.0.

## 5-2 IP Addresses in FINS Communications

### 5-2-1 Specifying Nodes in FINS Communications Services

With FINS communications services on an Ethernet network, IP addresses, UDP port numbers, and TCP port numbers are paired with FINS node addresses to specify nodes on the network.

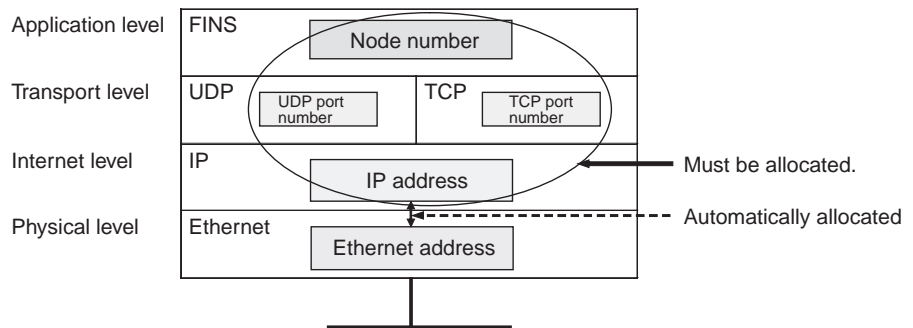

**Note** Use the Node Address Setting Switches (NODE NO.) on the front of the EtherNet/IP Unit or, for the built-in EtherNet/IP port, on the front of the CPU Unit to set the FINS node address.

### Allocating Addresses to EtherNet/IP Units and Built-in EtherNet/IP Ports

#### FINS Message Reception for EtherNet/IP Units or Built-in EtherNet/IP Ports

The IP address, FINS/UDP port number, and FINS/TCP port number set for the EtherNet/IP Unit or built-in EtherNet/IP port are mainly used when receiving FINS communications messages.

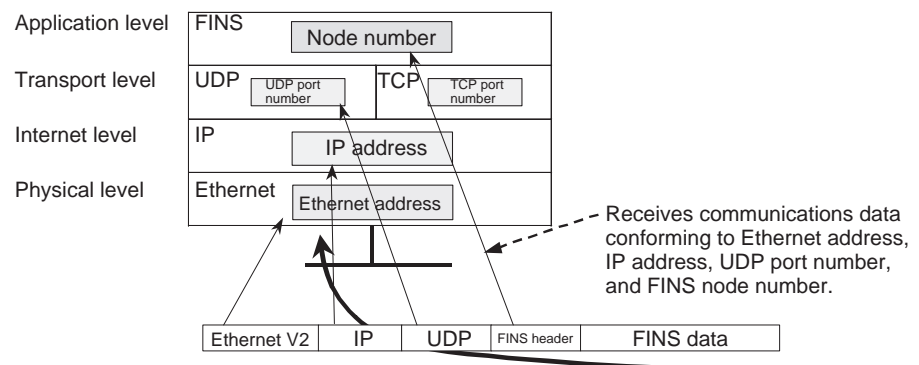

- Ethernet address: A fixed number is assigned to each EtherNet/IP Unit or built-in EtherNet/IP port and it cannot be changed.
- IP address: Use the default IP address (192.168.250.FINS\_node number), set the address in the allocated DM Area words, or set the address on the TCP/IP Tab Page of the Edit Parameters Dialog Box from the CX-Programmer.
- FINS/UDP port No.: Use the default FINS/UDP port number (9600) or set the number on the FINS/UDP Tab Page of the Edit Parameters Dialog Box from the CX-Programmer.
- FINS/TCP port No.: Use the default FINS/TCP port number (9600) or set the number on the FINS/UDP Tab Page of the Edit Parameters Dialog Box from the CX-Programmer.
- FINS node address: Set the number using the Node Address Setting Switches (NODE NO.) on the front of the EtherNet/IP Unit or built-in EtherNet/IP port.

**Pairing IP Addresses with FINS Node Addresses at Local Nodes**

A particular IP address is allocated to each communications node, including EtherNet/IP Units and built-in EtherNet/IP ports. The IP address must be paired with the FINS node address (1 to 254) by one of the following methods.

■ **Automatic Generation Method (Dynamic/Static)**

Set the relationship between the IP address and the FINS node address setting in the EtherNet/IP Unit or built-in EtherNet/IP port according to the following equation. If the setting does not conform to this equation, a setting error will be generated and the MS Indicator will flash red.

$$\text{FINS node address} = \text{IP address host number}$$

■ **IP Address Table Method and Combined Method**

With these methods, the IP address and the FINS node address setting in the EtherNet/IP Unit or built-in EtherNet/IP port have no particular relationship. Set both the FINS node address and the IP address so that they are not duplicated in the network.

**Sending FINS Messages from EtherNet/IP Units or Built-in EtherNet/IP Ports**

When the EtherNet/IP Unit or built-in EtherNet/IP port sends a FINS message, it is necessary to determine the remote node's IP address, UDP port number, and TCP port number. The relationships between all addresses, such as remote FINS node addresses and IP addresses, are managed by an internal table at the EtherNet/IP Unit or built-in EtherNet/IP port.

Remote FINS node address	Remote IP address (Example)	Connection	Remote port number (Example)
1	192.168.250.1	UDP	9600
2	192.168.250.2	UDP	9600
to			
254	192.168.250.254	UDP	9600

When the EtherNet/IP Unit or built-in EtherNet/IP port is turned ON or restarted, the internal table is generated automatically from the various settings that have been made. Depending on the setting method used, data such as remote IP addresses may be changed dynamically. (Dynamic changes can be prohibited.)

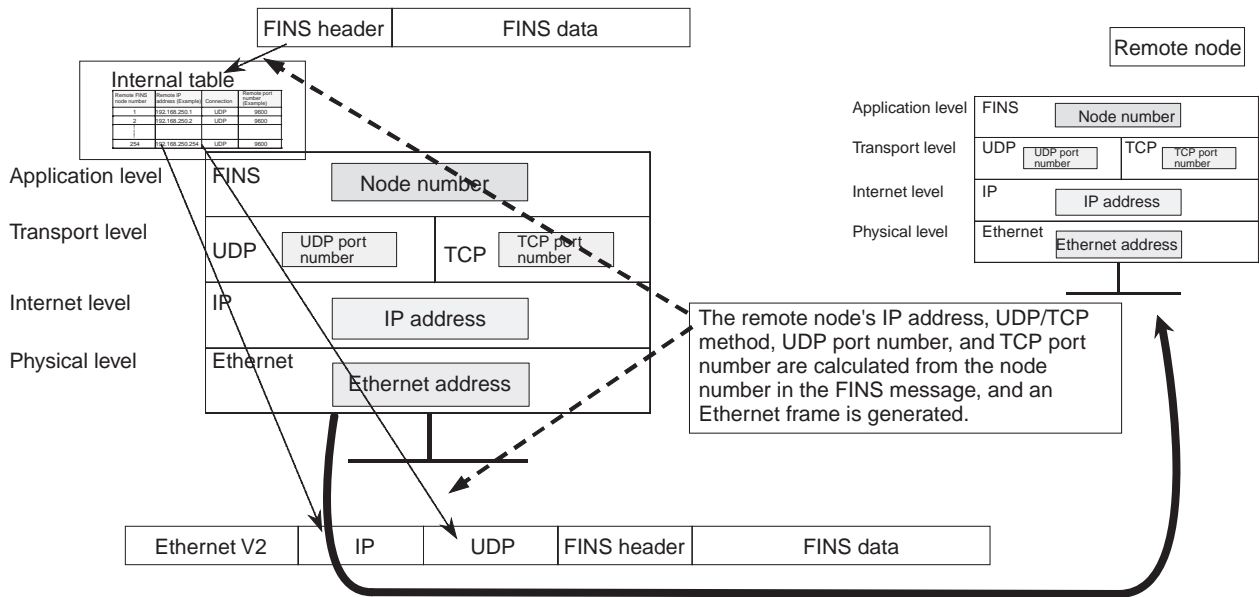

### 5-2-2 Pairing Addresses in Internal Tables

#### FINS/UDP Communications Methods

##### Automatic Generation (Dynamic)

When the EtherNet/IP Unit or built-in EtherNet/IP port is turned ON or restarted, the following values are set for addresses in the internal table.

- Remote IP address: Local IP address network number + remote FINS node address
- Remote UDP port number: UDP port number set for local Unit
- Connection method: FINS/UDP

With the dynamic method, data in an internal table that has been generated can be dynamically converted according to FINS messages received from remote nodes. This is enabled when the remote node is a device such as a personal computer and IP addresses are dynamically changed by a method such as DHCP.

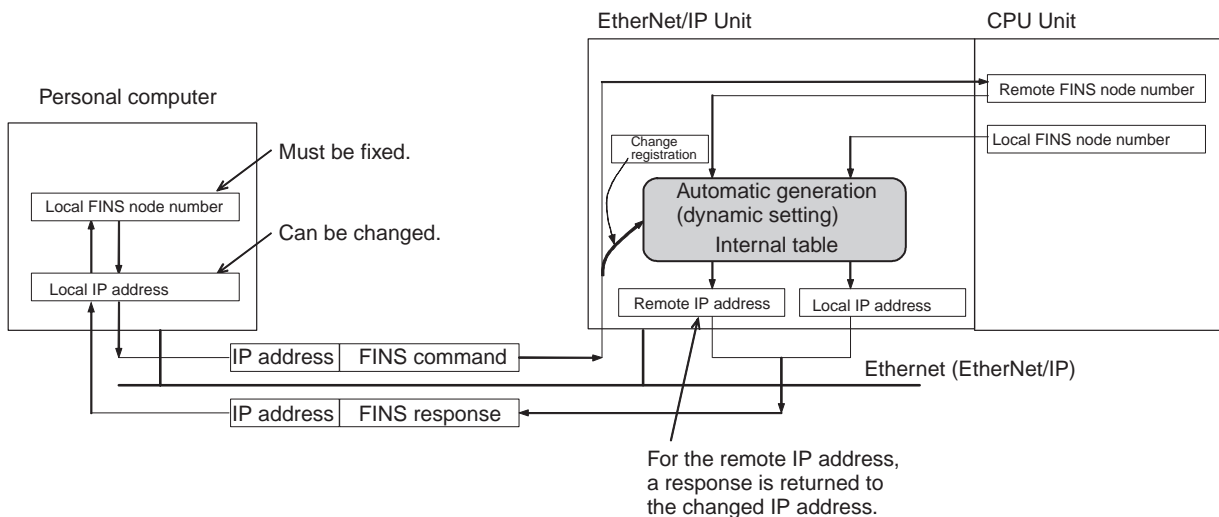

**Automatic Generation (Static)**

With the static method as well, the following values are set for addresses in the internal table when the EtherNet/IP Unit or built-in EtherNet/IP port is turned ON or restarted.

- Remote IP address: Local IP address network number + remote FINS node address
- Remote UDP port number: UDP port number set for local Unit
- Connection method: FINS/UDP

With the static method, however, data in an internal table that has been generated is not freely changed.

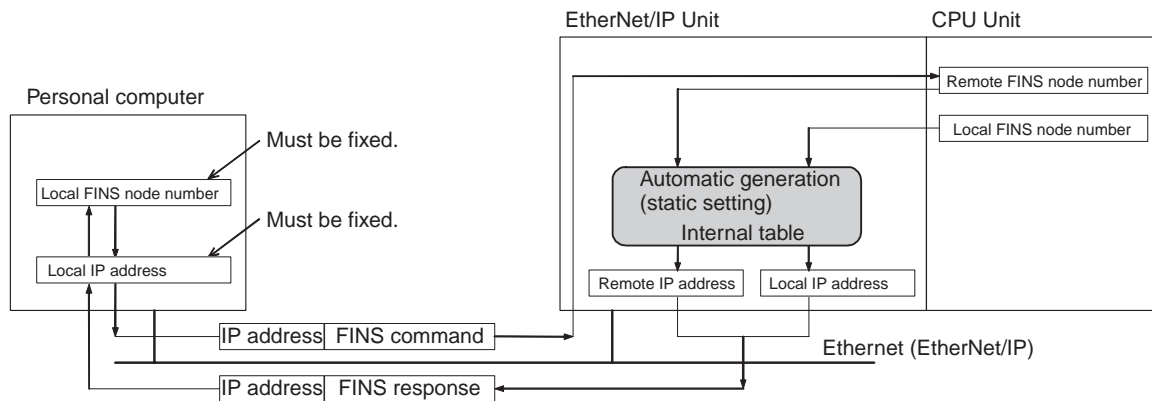

**IP Address Table Method**

With this method, FINS node addresses are converted to IP addresses based on a preset correspondence table (IP address table).

The IP address table is set on the FINS/UDP Tab Page of the Edit Parameters Dialog Box of the CX-Programmer. Nodes can be registered even if they are in different segments and have different network IDs

The internal table will be as follows:

- FINS Node Address Registered to IP Address Table  
The following address is registered to the internal table.
  - Remote IP address: IP address registered to IP address table
  - Remote UDP port number: UDP port number set for local Unit
  - Connection method: FINS/UDP
- FINS Node Address Not Registered to IP Address Table  
The following address is registered to the internal table.
  - Remote IP address: 0.0.0.0
  - Remote UDP port number: UDP port number set for local Unit
  - Connection method: FINS/UDP

With the IP address table method, records of FINS nodes registered to the IP address table are not changed dynamically. When the Unit is turned ON or restarted, the IP addresses of remote FINS nodes registered with an IP address of 0.0.0.0 can be changed dynamically according to FINS messages received from remote nodes. This can be used effectively when the remote node is a device such as a personal computer and IP addresses are dynamically changed by a method such as DHCP.

**Example**

**When FINS Command is Sent**

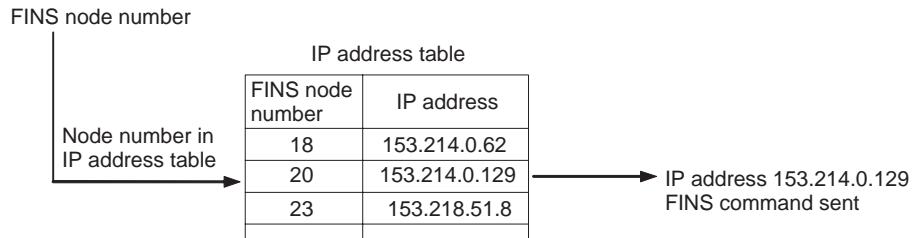

**When FINS Command is Received**

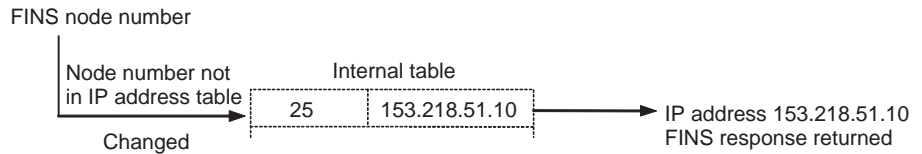

**Combined Method**

The combined method combines the IP address table method and the automatic generation method (dynamic).

First the IP address table is referenced. Then, if the applicable FINS node address is found, the corresponding IP address is read. If the FINS node address is not found, the IP address is calculated using the automatic generation method (dynamic).

The internal table will be as follows:

- FINS Node Address Registered to IP Address Table  
The following address is registered to the internal table.
  - Remote IP address: IP address registered in IP address table
  - Remote UDP port number: UDP port number set for local Unit
  - Connection method: FINS/UDP
- FINS Node Address Not Registered to IP Address Table  
The following address is registered to the internal table.
  - Remote IP address: Local IP address network number + FINS node address
  - Remote UDP port number: UDP port number set for local Unit
  - Connection method: FINS/UDP

With the combined method, records of FINS nodes registered to the IP address table are not dynamically changed. When the Unit is turned ON or restarted and the IP address of a remote FINS node is not registered in the IP table, the IP address can be changed dynamically according to FINS messages received from the remote node. This can be used effectively when the remote node is a device such as a personal computer and IP addresses are dynamically changed by a method such as DHCP.



**Example**

**When FINS Command is Sent**

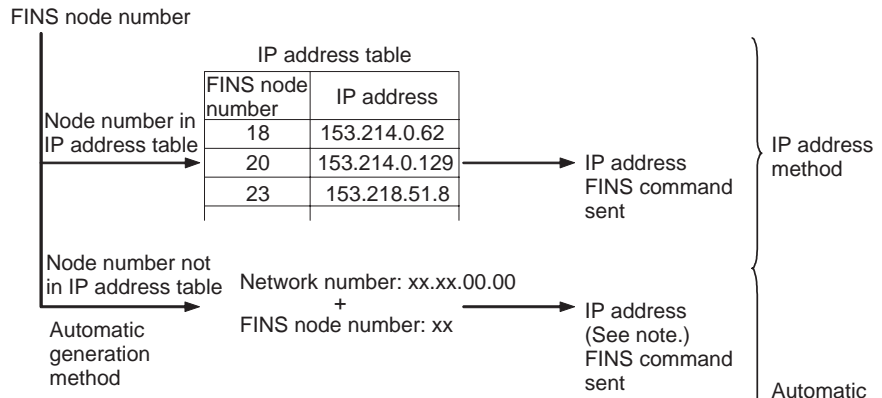

**When FINS Command is Received**

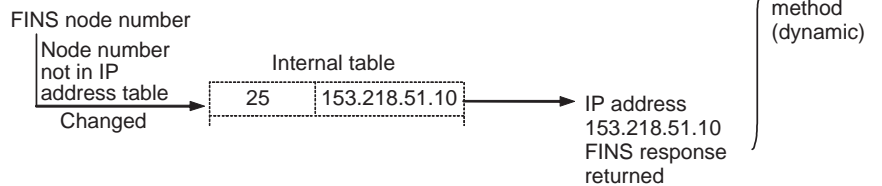

**Note** When an internal table IP address has been changed with the reception of a FINS command, this is sent to the IP address in the internal table.

**Prohibiting Dynamically Changing Remote IP Addresses**

With EtherNet/IP Units and built-in EtherNet/IP ports, it is possible to prohibit (protect against) dynamic changes to remote IP addresses by each method (automatic generation, IP address table, or combined method). Use the CX-Programmer to make this setting.

When dynamically changing remote (destination) IP addresses is prohibited, the internal table for each method is maintained in the same state it had when the power was turned ON or restarted. Therefore, protection can be provided against access using FINS/UDP from personal computers or other devices that have dynamically changing IP addresses. To prohibit dynamic changes, clear the selection of the *Dynamic change the target IP addresses* Option on the FINS/UDP Tab Page in the Edit Parameters Dialog Box of the CX-Programmer.

**Using the ETN11-compatible Mode**

With EtherNet/IP Units and built-in EtherNet/IP ports, operating specifications can be made compatible with the CS1W-ETN11/CJ1W-ETN11 for all methods (automatic generation (dynamic), I/O address table, or combined). (Dynamic changes, however, are prohibited for the destination IP address in ETN11-compatible mode.) While in ETN11-compatible mode, the following operations will be performed the same as they are for the CS1W-ETN11/CJ1W-ETN11 for FINS/UDP command data sent from a UDP port number other than the local FINS/UDP port number (default: 9600) set on the FINS/UDP Tab Page.

- If the command data is addressed to an Ethernet Unit, a FINS response will be sent to the source UDP port number.
- If the command data is for any other Unit, such as the CPU Unit, a FINS response will be sent to the UDP port number set as the FINS/UDP port number.

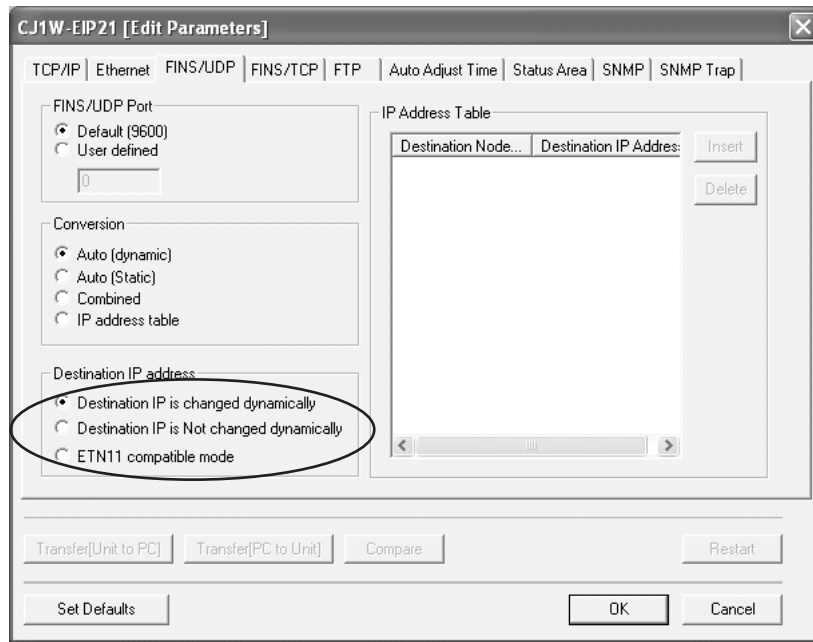

**Note** If the ETN11-compatible mode is used, the internal table will retain the same content from when it was created after the EtherNet/IP Unit was turned ON or restarted. This feature provides protection from access via FINS/UDP from computers that dynamically change their IP address.

**FINS/TCP Communications Method**

**Pairing in the FINS/TCP Method**

With the FINS/TCP method, communications are first established for each connection, and then remote FINS node addresses are mutually converted. (See note.) After the FINS node address is converted, FINS message communications are executed.

In this way, remote FINS node addresses and remote IP addresses are paired for each connection. Therefore, with the FINS/TCP method, there is no need to set IP address conversions (i.e., pairing FINS node addresses with IP addresses) as with FINS/UDP. On the other hand, it is necessary to set the remote IP address for each connection in the FINS/TCP Tab Page of the Network Configurator's Edit Parameters Dialog Box.

**Note** The internal table is changed after connections are established.

**Internal Processing**

The EtherNet/IP Unit or built-in EtherNet/IP port executes the following processing when the FINS/TCP method is used.

■ **Local Device: FINS/TCP Client**

- 1,2,3... 1. Connections are established in TCP/IP protocol with the remote IP addresses set for FINS/TCP connections in the FINS/TCP Tab Page of the CX-Programmer's Edit Parameters Dialog Box.
2. The remote node (i.e., the server) is notified of the FINS node address for the local device.
3. Notification is received from the remote node (i.e., the server) of the remote node's FINS node address.
4. The EtherNet/IP Unit or built-in EtherNet/IP port changes the internal table (FINS node address, IP address, and TCP port number).
5. FINS messages can then be sent and received.

■ Local Device: FINS/TCP Server

- 1,2,3...
1. A request to open a connection is received in TCP/IP protocol from the remote device (i.e., the client, either a personal computer, an EtherNet/IP Unit or built-in EtherNet/IP port), and the connection is established.
  2. Notification is received from the remote node (i.e., the client) of the remote node's FINS node address.
  3. The local device provides notification of the local FINS node address.
  4. The EtherNet/IP Unit or built-in EtherNet/IP port changes the internal node correspondence table (FINS node address, IP address, and TCP port number).
  5. FINS messages can then be sent and received.

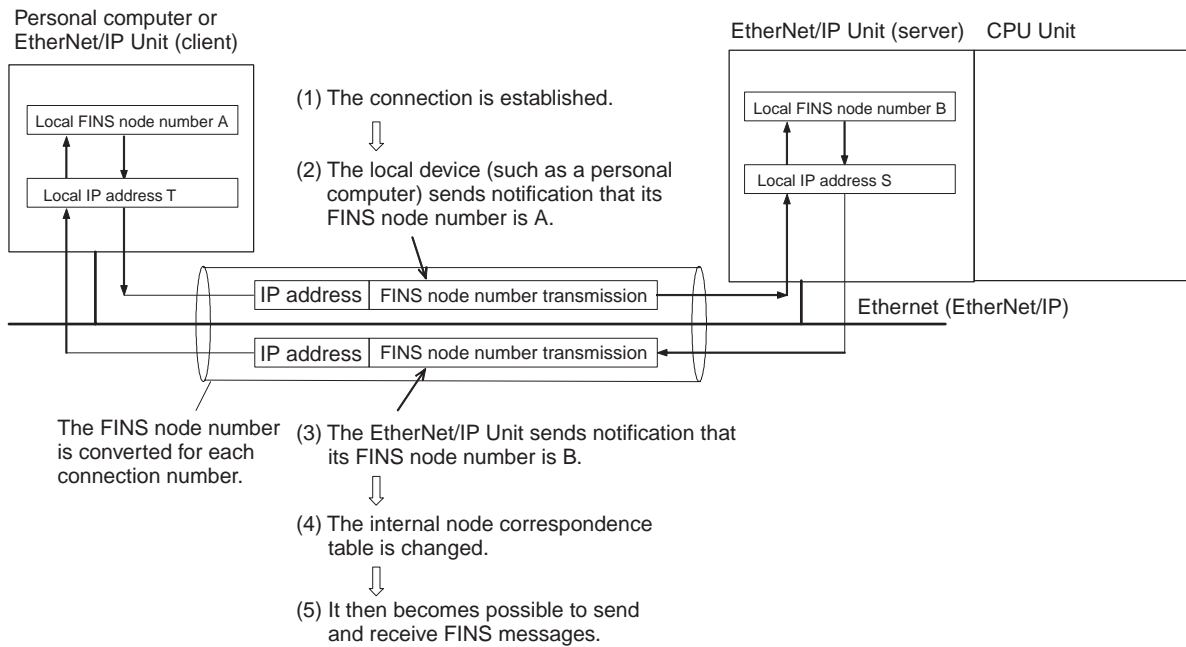

**Setting FINS/TCP Connections**

The procedure for setting FINS/TCP connections involves the items described below. The settings are made individually for each connection (numbers 1 to 16) on the FINS/TCP Tab Page of the Edit Parameters Dialog Box of the CX-Programmer.

■ Local Device: Server

- 1,2,3...
1. Set the server.
  2. Set IP addresses for the devices to be connected.  
If the option for protection of IP addresses is selected, set the IP addresses for clients where connections are permitted. (This step can be omitted.)
  3. Automatic FINS node address allocation:  
If the client (generally a personal computer) supports FINS/TCP, and if it is to be used without setting a FINS node address, the value set here (from 239 to 254) can be allocated to the client. The default settings should normally be used.

■ Local Device: Client

- 1,2,3...
1. Set the client.

2. Set IP addresses for the devices to be connected.  
 Set the IP address for the remote EtherNet/IP Unit or built-in EtherNet/IP port (i.e., the server) connected by FINS/TCP.  
 This setting must be made if this EtherNet/IP Unit will be used as a FINS/TCP client.

### 5-2-3 Application Examples

#### Responding to Computers with Changed IP Addresses

##### FINS/UDP Communications Method

With FINS/UDP, whether using the automatic conversion method (dynamic), the IP address table method, or the combined method, remote FINS node addresses and remote IP addresses in the internal table are changed after FINS messages are received. Therefore, even when a FINS command has been received from a personal computer (a DHCP client computer) for which the IP address is dynamically changed, a response can still be sent back to the computer (the DHCP client computer) from which the command originated.

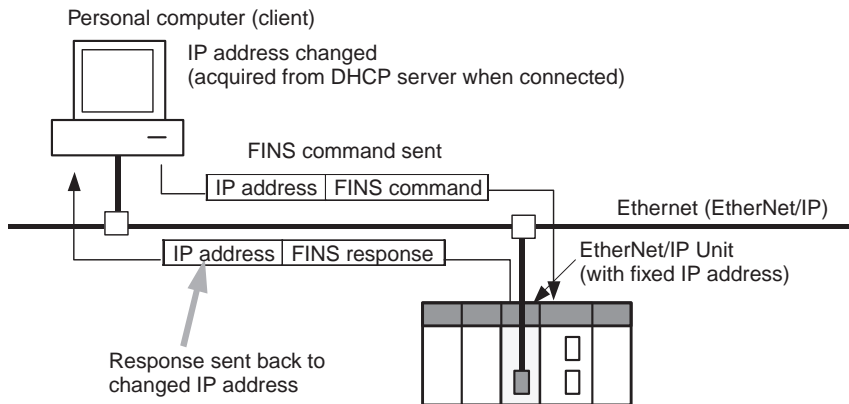

##### FINS/TCP Communications Method

With FINS/TCP, FINS node addresses and IP addresses in the internal table are changed with each connection that is established. Therefore, even when a FINS command has been received from a personal computer (a DHCP client computer) for which the IP address is dynamically changed, a response can still be sent back to the computer (the DHCP client computer) from which the command originated.

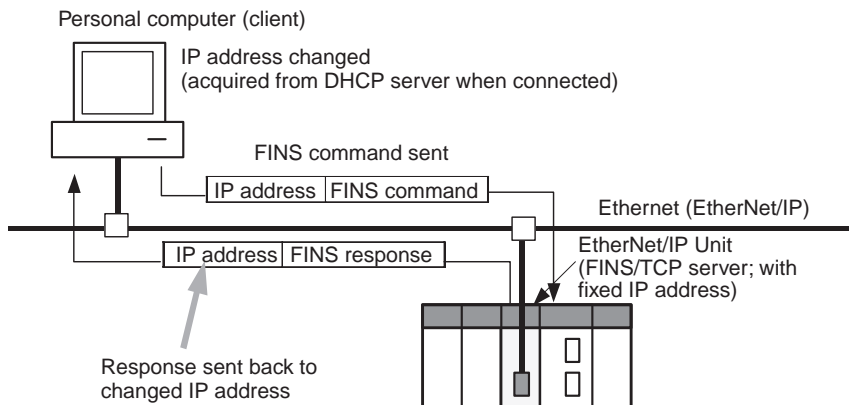

**Note** Automatic IP Address Setting by DHCP Service  
 DHCP service is a method whereby a DHCP server collectively manages all of the IP address in a network.  
 Nodes that are functioning as clients acquire IP addresses from the DHCP

server whenever the system is started. Therefore, at a personal computer using the DHCP service, IP addresses may be different with each system startup.

DHCP service is mainly used for automatic settings in devices such as personal computers that are used for client applications. Nodes used for server applications, such as mail servers, are normally allocated fixed IP addresses. EtherNet/IP Units and built-in EtherNet/IP ports in PLC systems are also allocated fixed IP addresses.

**Simultaneously Running Multiple Applications on a Personal Computer**

In communications involving previous models, multiple communications applications were configured on personal computers according to data accessing uses, and the fact that no more than one UDP port number for FINS communications could be used on any given computer created a problem. This EtherNet/IP Unit provides a practical solution with an internal table that pairs remote nodes (applications) with FINS node addresses, enabling dynamic changes.

**FINS/UDP Communications Method**

FINS nodes are allocated individually for each application on the computer, and the respective FINS/UDP port numbers that are used are also allocated individually. When FINS/UDP FINS commands are sent from individual applications to the EtherNet/IP Unit or built-in EtherNet/IP port, the respective remote IP addresses and remote port numbers in the internal table are dynamically changed.

**FINS/TCP Communications Method**

With this method as well, FINS nodes are allocated individually for each application on the computer, and the respective FINS/TCP port numbers that are used are also allocated individually. Each application is positioned with a FINS/TCP client, and requests the opening of a connection with the FINS/TCP server of the EtherNet/IP Unit or built-in EtherNet/IP port. When the connection is established, the respective remote IP address and remote port number in the internal table are dynamically changed.

**5-2-4 Related Products and Communications/Setting Methods**

**Models Supporting Automatic Generation Method (Dynamic)**

Product	Model/Series/Version	Supports automatic generation method (dynamic)?	
CS-series Ethernet Unit	100BASE-TX	CS1W-ETN21	Yes
	10BASE-5	CS1W-ETN01	No: Set by automatic generation method or combined method. Communications are not possible with personal computers with variable IP addresses.
	10BASE-T	CS1W-ETN11	
CJ-series Ethernet Unit	100BASE-TX	CJ1W-ETN21	Yes
	10BASE-T	CJ1W-ETN11	No: Set by automatic generation method or combined method. Communications are not possible with personal computers with variable IP addresses.
CV/CVM1-series Ethernet Unit	10BASE-5	CV500-ETN01	
FinsGateway		Version 4.xx or lower	No: Set by automatic generation method or combined method. Communications are not possible with personal computers with variable IP addresses.
		Version 2003 or higher	Yes

Product	Model/Series/ Version	Supports automatic generation method (dynamic)?
Programmable Terminal	NS Series	No: Set manually so that automatic settings can be used with the automatic generation method.
Open Network Controller (ONC)	---	

**Models Supporting Automatic Generation Method (Static)**

Product	Model/Series/ Version	Supports automatic generation method (static)?	
CS-series Ethernet Unit	100BASE-TX	CS1W-ETN21	Yes
	10BASE-5	CS1W-ETN01	Yes: Simply called "automatic generation method."
	10BASE-T	CS1W-ETN11	
CJ-series Ethernet Unit	100BASE-TX	CJ1W-ETN21	Yes
	10BASE-T	CJ1W-ETN11	Yes: Simply called "automatic generation method."
CV/CVM1-series Ethernet Unit	10BASE-5	CV500-ETN01	
FinsGateway		Version 4.xx or lower	Yes
		Version 2003 or higher	
Programmable Terminal	NS Series	No: Set manually so that automatic settings can be used with the automatic generation method.	
Open Network Controller (ONC)	---		

**Models Supporting IP Address Table Method**

Product	Model/Series/ Version	Supports IP address table method?	
CS-series Ethernet Unit	100BASE-TX	CS1W-ETN21	Yes
	10BASE-5	CS1W-ETN01	
	10BASE-T	CS1W-ETN11	
CJ-series Ethernet Unit	100BASE-TX	CJ1W-ETN21	
	10BASE-T	CJ1W-ETN11	
CV/CVM1-series Ethernet Unit	10BASE-5	CV500-ETN01	
FinsGateway		Version 4.xx or lower	
		Version 2003 or higher	
Programmable Terminal	NS Series	No: Set manually. FINS communications are not possible with personal computers set automatically by DHCP.	
Open Network Controller (ONC)	---		

**Models that Can Use the Combined Method**

Product		Model/Series/Version	Supports combined method?
CS-series Ethernet Unit	100BASE-TX	CS1W-ETN21	Yes
	10BASE-5	CS1W-ETN01	No
	10BASE-T	CS1W-ETN11	No
CJ-series Ethernet Unit	100BASE-TX	CJ1W-ETN21	Yes
	10BASE-T	CJ1W-ETN11	No
CV/CVM1-series Ethernet Unit	10BASE-5	CV500-ETN01	No
FinsGateway		Version 4.xx or lower	No
		Version 2003 or higher	Yes
Programmable Terminal		NS Series	No: Set manually. FINS communications are not possible with personal computers set automatically by DHCP.
Open Network Controller (ONC)		---	

**5-2-5 Pairing IP Addresses and FINS Node Addresses**

The following table shows the methods for pairing IP address and FINS node addresses, and the relation between fixed and variable address, for both FINS/UDP and FINS/TCP.

Communications method	Method of pairing of IP addresses and FINS node addresses	IP address determination		Client (personal computer or PLC)		Server (PLC)	
				FINS node address	IP address	FINS node address	IP address
FINS/UDP	By pairing FINS node addresses with IP addresses in Ethernet	IP address conversion	Automatic generation method (static)	Fixed	Fixed	Fixed	Fixed
			Automatic generation method (dynamic)	Fixed	Fixed or variable	Fixed	Fixed
			IP address table method	Fixed	Fixed or variable	Fixed	Fixed
			Combined method	Fixed	Fixed or variable	Fixed	Fixed
FINS/TCP	By automatic conversion of FINS node addresses at Ether-Net/IP Unit and remote node (and then sending and receiving data)	Automatic	Connection method (automatic FINS node address conversion)	Fixed or can be allocated automatically when not determined.	Fixed or variable	Fixed	Fixed

## 5-3 Private and Global Addresses

### 5-3-1 Private and Global Addresses

There are two kinds of IP addresses, private and global.

- Global addresses: These are IP addresses that connect directly to the Internet. Allocated by application to NIC, each address is unique in the world, and as many as 4.3 million can be allocated worldwide.
- Private addresses: These are IP addresses for Intranet (LAN) use, and cannot connect directly to the Internet. Frames that include private IP addresses are restricted by the router from being sent outside the LAN.

Generally, as shown below, global addresses in the intranet are allocated only to IP routers (such as broadband routers) interfacing with the Internet. All other nodes in the intranet, including the EtherNet/IP Unit or built-in EtherNet/IP port, are allocated private addresses.

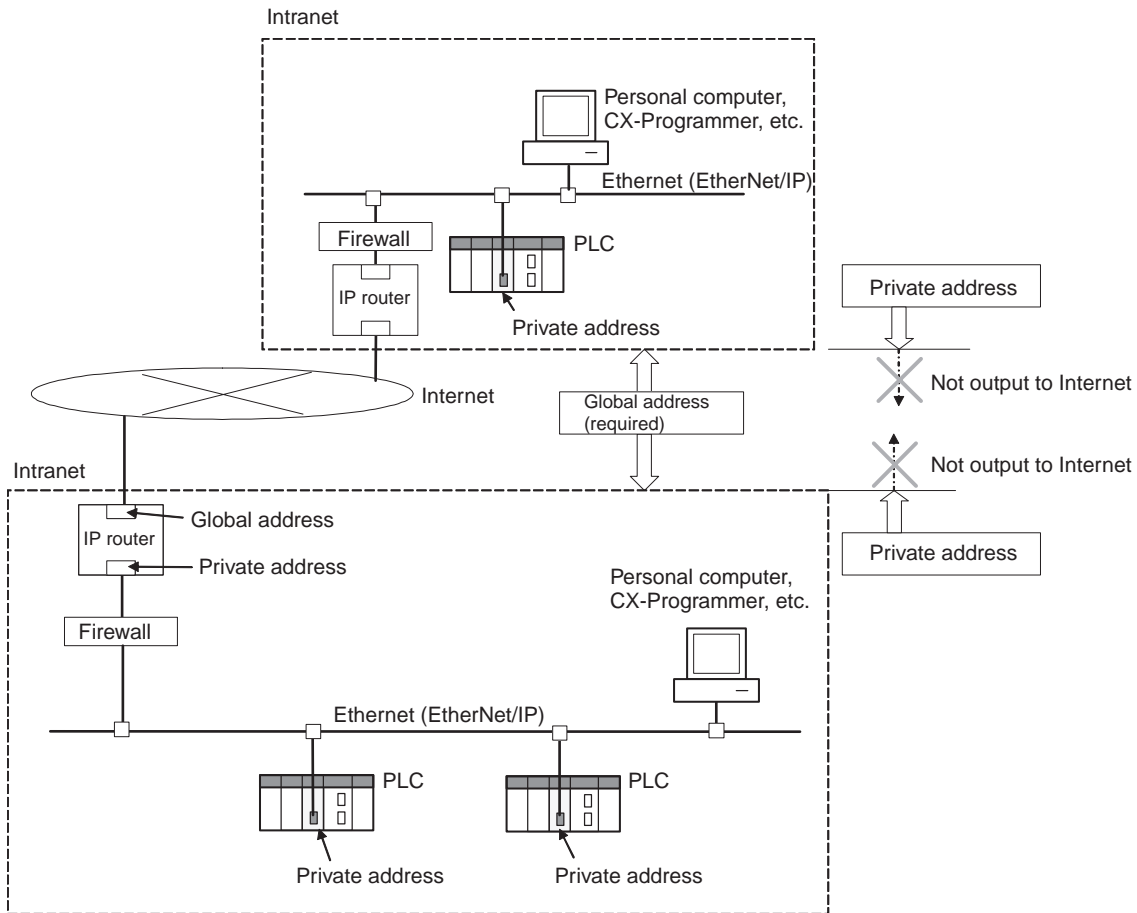

#### Communications Services That Require Global Addresses for EtherNet/IP Units and built-in EtherNet/IP ports

A global address is required for the IP addresses of the EtherNet/IP Units and built-in EtherNet/IP port when the following communications services are used over the Internet.

- FINS communications services
- Explicit message communications services



### 5-3-2 Using a Private Address for the EtherNet/IP Unit

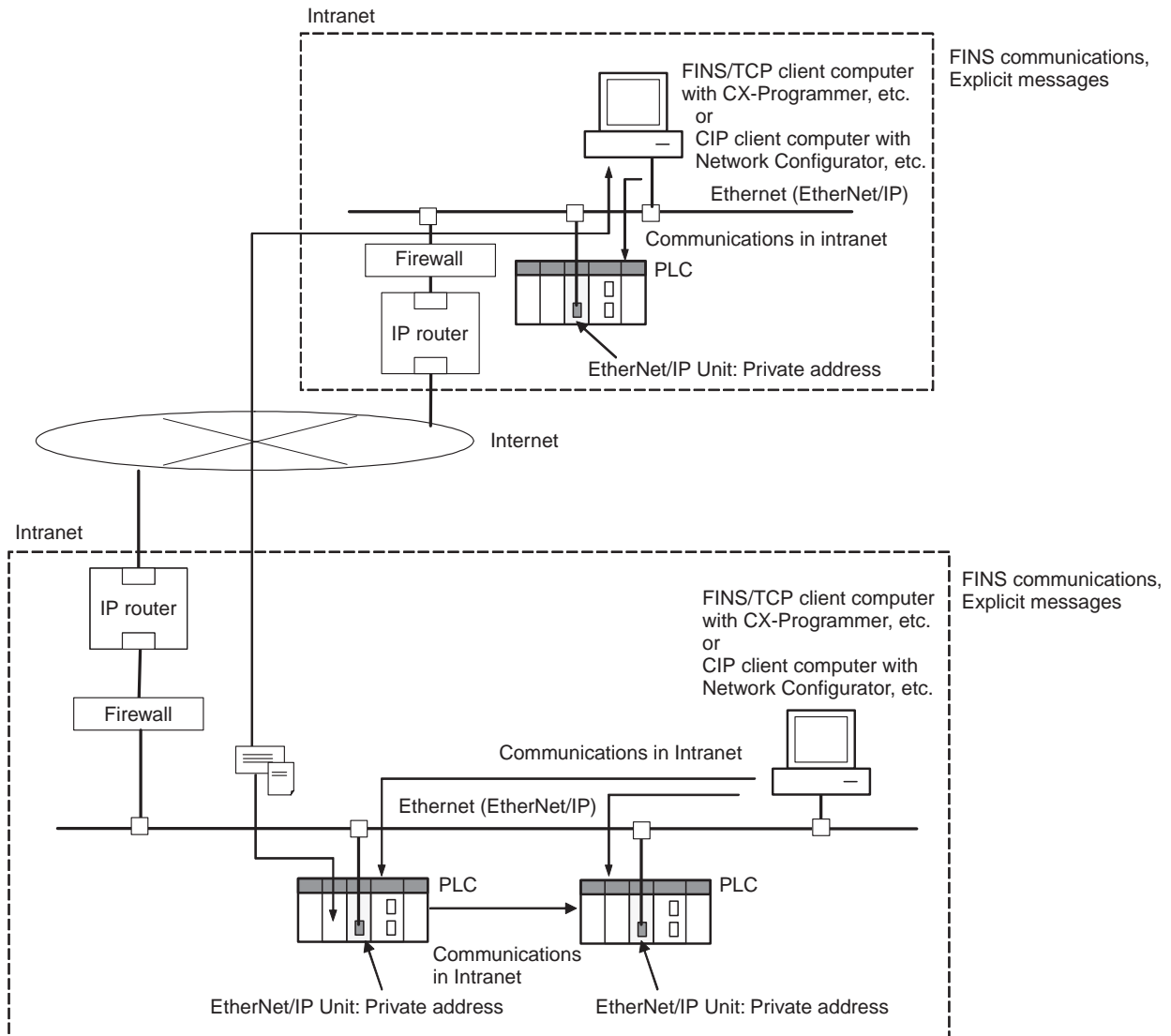

#### Conditions for Using Communications Applications

When the EtherNet/IP Unit or built-in EtherNet/IP port has a private address, communications applications can be used under the following conditions:

##### ■ FINS Communications Service

- The FINS communications service can be executed on the intranet between EtherNet/IP Units and built-in EtherNet/IP ports with private addresses only.  
A device such as a personal computer (with a FINS application, including the CX-Programmer) cannot connect online and communicate over the Internet with an EtherNet/IP Unit or built-in EtherNet/IP port that has a private address. FINS communications are also not possible over the Internet between EtherNet/IP Units and or built-in EtherNet/IP ports with private addresses.
- Either FINS/TCP or FINS/UDP can be used for the FINS communications service.
- With FINS/UDP, all of the EtherNet/IP Unit or built-in EtherNet/IP port IP address conversion methods can be used.

- With FINS/UDP, when the IP address (private address) of a computer serving as a DHCP client is changed, the IP address conversion method of the EtherNet/IP Unit or built-in EtherNet/IP port will be the automatic generation method (dynamic), the combined method, or the IP address table method. When FINS/TCP is used, IP addresses can be changed automatically.

■ **Explicit Message Communications Service**

- The explicit message communications service can be executed on the intranet between EtherNet/IP Units and built-in EtherNet/IP ports with private addresses only.
- A device such as a personal computer (CIP applications including the Network Configurator) cannot connect online and communicate over the Internet with an EtherNet/IP Unit or built-in EtherNet/IP port that has a private address. Explicit message communications are also not possible over the Internet between EtherNet/IP Units and built-in EtherNet/IP ports with private addresses.

**Note** Network Security and Firewalls

Setting up an intranet through a global address involves network security considerations. Before doing so, be sure to consult with a network specialist and consider installing a firewall.

Once a firewall has been set up by a communications technician, on the other hand, there may be some applications that cannot be used. Be sure to check first with the communications technician.

### 5-3-3 EtherNet/IP Unit with a Global Address

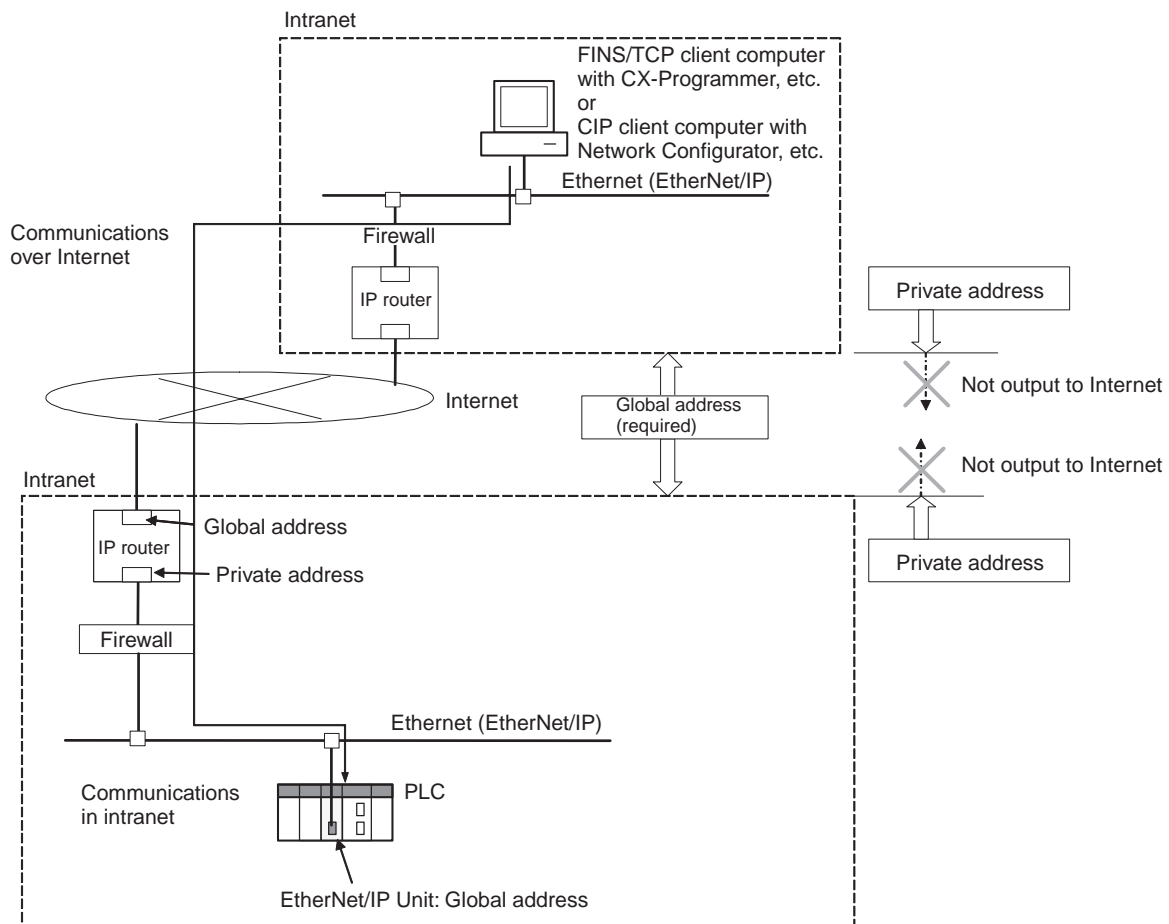

#### Conditions for Using Communications Applications

Communications applications can be used over the Internet under the following conditions:

##### ■ FINS Communications Service

- A device such as a personal computer (a FINS application, including the CX-Programmer) can connect online and communicate over the Internet with an EtherNet/IP Unit or built-in EtherNet/IP port that has a global address.
- FINS/TCP is recommended as the FINS communications service method. FINS/TCP is more reliable than FINS/UDP in terms of communications errors involving IP routers.
- The IP address table method is used as the IP address conversion method of the EtherNet/IP Unit or built-in EtherNet/IP port.
- The TCP port number to be used for FINS/TCP cannot be used if prohibited by a firewall in the communications path.

##### ■ Explicit Message Communications Service

- A device such as a personal computer (a CIP application including the Network Configurator) can connect online and communicate over the Internet with an EtherNet/IP Unit or built-in EtherNet/IP port that has a global address.

- If the TCP port number (44818) or UDP port number (44818) that is used for EtherNet/IP cannot be used if prohibited by a firewall in the communications path.

**Note** Network Security and Firewalls

Setting a global IP address for an EtherNet/IP Unit or built-in EtherNet/IP port involves network security considerations. It is recommended that the user contract with a communications company for a dedicated line, rather than using a general line such as a broadband line. Also, be sure to consult with a network specialist and consider security measures such as a firewall. Once a firewall has been set up by a communications technician, on the other hand, there may be some applications that cannot be used. Be sure to check first with the communications technician.

# SECTION 6

## Tag Data Link Functions

This section describes tag data link functions and related Network Configurator operations.

6-1	Overview of Tag Data Links . . . . .	114
6-1-1	Tag Data Links . . . . .	114
6-1-2	Overview of Operation . . . . .	114
6-1-3	Tag Data Link Functions and Specifications . . . . .	117
6-1-4	Data Link Data Areas . . . . .	118
6-2	Setting Tag Data Links . . . . .	123
6-2-1	Starting the Network Configurator . . . . .	123
6-2-2	Tag Data Link Setting Procedure . . . . .	126
6-2-3	Registering Devices . . . . .	127
6-2-4	Creating Tags and Tag Sets. . . . .	128
6-2-5	Connection Settings . . . . .	143
6-2-6	Setting Tags Using Data Link Tool. . . . .	152
6-2-7	Creating Connections Using the Wizard . . . . .	158
6-2-8	Creating Connections by Device Dragging and Dropping. . . . .	161
6-2-9	Connecting the Network Configurator to the Network . . . . .	163
6-2-10	Downloading Tag Data Link Parameters . . . . .	170
6-2-11	Uploading Tag Data Link Parameters. . . . .	173
6-2-12	Verifying the Tag Data Links . . . . .	174
6-2-13	Starting and Stopping Tag Data Links . . . . .	177
6-2-14	Clearing the Device Parameters . . . . .	178
6-2-15	Saving the Network Configuration File . . . . .	179
6-2-16	Reading a Network Configuration File. . . . .	180
6-2-17	Checking Connections . . . . .	182
6-2-18	Changing Devices. . . . .	183
6-2-19	Displaying Device Status . . . . .	183
6-3	Ladder Programming with Tag Data Links. . . . .	185
6-3-1	Ladder Programming Related to Tag Data Links. . . . .	185
6-3-2	Status Flags Related to Tag Data Links . . . . .	188

## 6-1 Overview of Tag Data Links

### 6-1-1 Tag Data Links

Tag data links enable cyclic data exchanges on an EtherNet/IP network between PLCs or between PLCs and another device. I/O memory addresses (e.g., in the CIO or DM Area) and symbols can be assigned to tags. The settings for tag data links are made using the Network Configurator. Refer to 6-2 *Setting Tag Data Links* for information on how to make the settings.

**Note** Symbols can be used in tags only for the CJ2H-CPU6□-EIP and CJ2M-CPU3□. If you are using a CJ1W-EIP21 or CS1W-EIP21 EtherNet/IP Unit that is mounted to a CJ2H-CPU6□ or any CPU Unit other than the CJ2H-CPU6□-EIP, use I/O memory addresses to set the tag data links.

With tag data links, one node requests the opening of a communications line called a connection to exchange data with another node. The node that requests opening the connection is called the originator, and the node that receives the request is called the target.

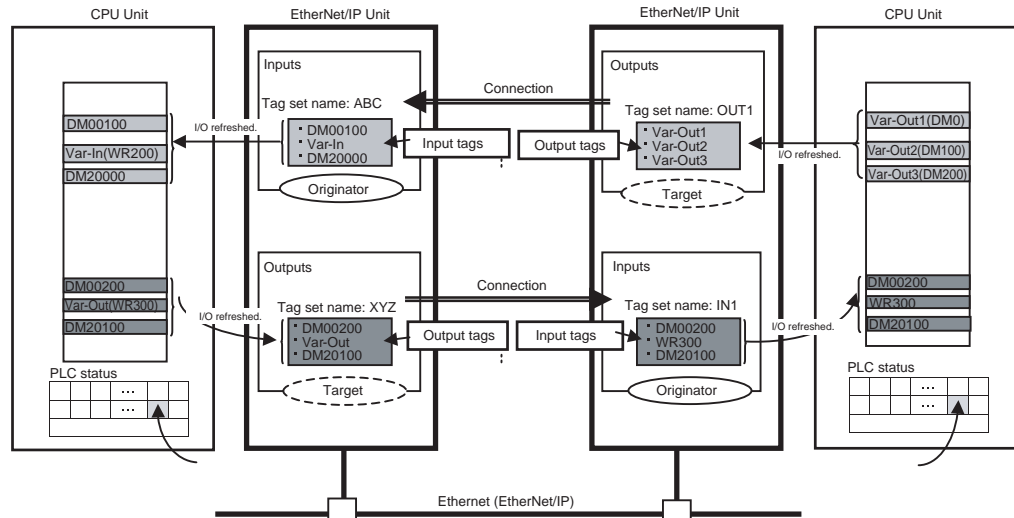

For communications between PLCs, the connection information is set in the EtherNet/IP Unit or built-in EtherNet/IP port of the PLC that receives data (i.e., the originator).

**Note** The specifications for using tag data links with the CJ2M built-in EtherNet/IP port on a CJ2M-CPU3□ CPU Unit are different from the specifications for EtherNet/IP Units (CJ1W-EIP21 or CS1W-EIP21) and the CJ2H built-in EtherNet/IP port on a CJ2H-CPU6□-EIP CPU Unit. Make sure you are using the correct specifications for the application.

Refer to 2-1-3 *Communications Specifications* for the communications specifications.

### 6-1-2 Overview of Operation

#### Setting and Downloading Tag Data Link Parameters

The tag data link parameters (e.g., connection information) that are described below are created using the Network Configurator, and then the parameters are downloaded to all originator devices on the EtherNet/IP network.

Make the following settings using the Network Configurator if tag data link functionality is used with the CJ2B-EIP21 built-in EtherNet/IP port on the CJ2H, CJ2M-EIP21 built-in EtherNet/IP port on the CJ2M, CS1W-EIP21, or CJ1W-EIP21.

### Tag Settings

Create input (reception) tags and output (send) tags for addresses in the CPU Unit's I/O memory areas or for symbols.

The following are the limits for tags that can be created with the CJ2B-EIP21 built-in EtherNet/IP port on the CJ2H, CJ2M-EIP21 built-in EtherNet/IP port on the CJ2M, CS1W-EIP21, or CJ1W-EIP21.

- A maximum of 32 tags can be created per Unit for the CJ2M-EIP21. A maximum of 256 tags can be created per Unit for other CPU Units.
- A maximum data size of 1,280 bytes (640 words)<sup>\*1</sup> can be used per tag for the CJ2M-EIP21. A maximum data size of 1,444 bytes (722 words) can be used per tag for other CPU Units.

<sup>\*1</sup> Unit version 2.0: 40 bytes (20 words) maximum.

With the CJ2H-CPU6□-EIP or CJ2M-CPU3□, you can create tags by importing network symbols (i.e., I/O allocation settings) that were created using the CX-Programmer into the Network Configurator. Output tags can be defined to clear output data to 0 or to hold the output data when PLC outputs are turned OFF.

### Setting Tag Sets

Create output tag sets and input tag sets and position them. (Up to eight tag sets can be created). The following are the limits on tag sets that can be created with the CJ2B-EIP21 built-in EtherNet/IP port on the CJ2H, CJ2M-EIP21 built-in EtherNet/IP port on the CJ2M, CS1W-EIP21, or CJ1W-EIP21.

- A maximum of 32 tag sets can be created per Unit for the CJ2M-EIP21. A maximum of 256 tag sets can be created per Unit for other CPU Units.
- A maximum data size of 1,280 bytes (640 words)<sup>\*1</sup> can be used per tag set for the CJ2M-EIP21. A maximum data size of 1,444 bytes (722 words) can be used per tag set for other CPU Units.

<sup>\*1</sup> Unit version 2.0: 40 bytes (20 words) maximum.

The PLC status can be specified in a tag set to indicate the CPU Unit's operating status (operating information and error information).

### Setting Connections

The target device output tag set and the originator device input tag set are associated as connections. A maximum of 256 connections can be opened per Unit for the CJ2B-EIP21 built-in EtherNet/IP port on the CJ2H, CS1W-EIP21, or CJ1W-EIP21. A maximum of 32 connections can be opened per Unit for the CJ2M-EIP21 built-in EtherNet/IP port on the CJ2M.

### Counting Connections

The number of connections is the total of the number of input tag sets that receive data and the number of nodes that send data for output tag sets. (Refer to the following figure.) One connection is consumed for each connection setting whether the connection is a multicast connection or a unicast (point-to-point) connection.

Example of Calculating the Number of Connections

- EtherNet/IP Unit or built-in EtherNet/IP port with IP address of 192.168.250.254 in bidirectional connection with 128 nodes

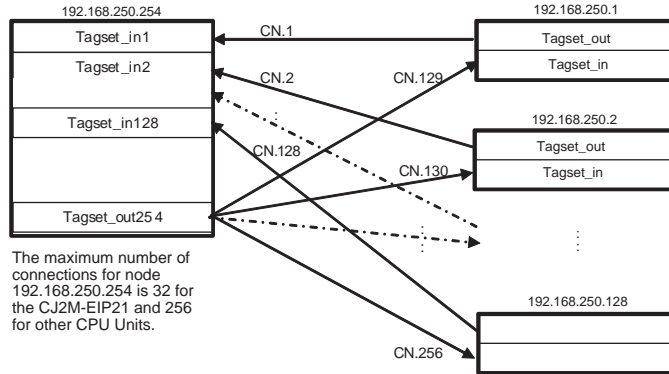

The maximum number of connections for node 192.168.250.254 is 32 for the CJ2M-EIP21 and 256 for other CPU Units.

Another EtherNet/IP Unit must be mounted to the PLC to increase the maximum number of connections. (Refer to the following figure.)

Example of Calculating the Number of Connections

- The maximum number of connections (32 for the CJ2M-EIP21 and 256 for other CPU Units) per Unit would be exceeded if an EtherNet/IP Unit or built-in EtherNet/IP port with an IP address of 192.168.250.254 is used in a bidirectional connection with 129 nodes. In this case, bidirectional communications can be performed with 129 nodes or more by adding an EtherNet/IP Unit with the IP address of, for example, 192.168.250.253 to the same PLC, creating an output tag set in the new EtherNet/IP Unit, and creating connections.

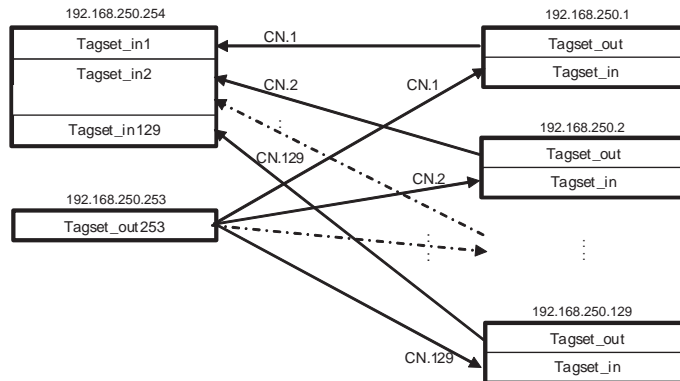

### Setting the Packet Interval (RPI)

The packet interval is the data I/O refresh cycle in the Ethernet circuit when performing tag data links, and can be set separately for each connection. The packet interval can be set to between 0.5 and 10,000 ms in units of 0.5 ms for the CJ2B-EIP21 (built-in EtherNet/IP port on the CJ2H), CS1W-EIP21, or CJ1W-EIP21. It can be set to between 1 and 10,000 ms in units of 0.5 ms for the CJ2M-EIP21 (built-in EtherNet/IP port on the CJ2M). The default setting is 50 ms.

With EtherNet/IP, data is exchanged on the communications line at the packet interval that is set for each connection, regardless of the number of nodes.

### Using Multicast and Unicast Communications

A multicast connection or unicast (point-to-point) connection can be selected as the connection type in the tag data link connection settings.

With a multicast connection, you can send an output tag set in one package to multiple nodes and make allocations to the input tag sets.

A unicast connection separately sends one output tag set to each node, and so it sends the same number of packets as the number of input tag sets.

Therefore, using multicast connections can decrease the communications load if one output tag set is sent to multiple nodes.



If multicast connections are used, however, use a switching hub that has multicast filtering, unless the tag set is received by all nodes in the network.

If a switching hub that does not have multicast filtering is used, the multicast packets will be broadcast to the entire network, and so packets will be sent to nodes that do not require them, which will cause the communications load on those nodes to increase.

This applies only if one output tag set is sent to multiple nodes using a multicast connection with one packet, the connection type of the connections that receive the output tag set is multicast, and the connection I/O types, packet intervals (RPI), and timeout values are all the same.

**Note** The performance of communications devices is limited to some extent by the limitations of each product's specifications. Consequently, there are limits to the packet interval (RPI) settings. Refer to *10-2 Adjusting the Communications Load* and set an appropriate packet interval (RPI).

### Starting and Stopping Tag Data Links

Tag data links are automatically started when the data link parameters are downloaded from the Network Configurator. Thereafter, tag data links can be stopped and started for the entire network or individual devices from the Network Configurator. Starting and stopping tag data links for individual devices must be performed for the originator.

Software switches in allocated words can also be used to start and stop tag data links for the entire network. Refer to *6-2-13 Starting and Stopping Tag Data Links* for details.

### 6-1-3 Tag Data Link Functions and Specifications

Item	Specification
Communications type	Standard EtherNet/IP implicit communications (connection-type cyclic communications)
Setting method	After setting tags, tag sets, and connections with the Network Configurator, the tag data link parameters must be downloaded to all devices in the EtherNet/IP network.  With a CJ2H-CPU6□-EIP or CJ2M-CPU3□ CPU Unit, a symbol table can be created with the CX- Programmer and then imported into the Network Configurator to allocate tags.  After the parameters are downloaded, the EtherNet/IP Units are restarted to start the tag data links.
Tags	Applicable CPU Unit data: CIO Area, DM Area, EM Area, Holding Area, Work Area, and symbols. (See note.)  Number of words per tag: 640 max. (1,280 bytes) <sup>*1</sup> for CJ2M-EIP21, 722 max. (1,444 bytes) for other CPU Units  Number of tags per Unit: 32 max. for CJ2M-EIP21, 256 max. for other CPU Units  <b>Note</b> Supported only by the CJ2H-CPU6□-EIP and CJ2M-CPU3□. Network symbols (I/O allocation settings) that are created with the CX-Programmer can be imported to the Network Configurator.
Tag sets	Number of tags per tag set: 8 max. (7 max. if PLC status is included)  Number of words per tag set: 640 max. (1,280 bytes) <sup>*1</sup> for CJ2M-EIP21, 722 max. (1,444 bytes) for other CPU Units  Number of tag sets per Unit: 32 max. for CJ2M-EIP21, 256 max. for other CPU Units

Item	Specification
Maximum link data size per node (total size of all tags)	184,832 words max. (722 words × 256) (CJ2M-EIP21: 640 words max.)
Connections	Number of connections per Unit: 32 max. for CJ2M-EIP21, 256 max. for other CPU Units
Connection type	Each connection can be set for 1-to-1 (unicast) or 1-to-N (multicast) communications. (Default: Multicast)
Packet interval (RPI)	1 to 10,000 ms for CJ2M-EIP21 and 0.5 to 10,000 ms for other CPU Units (in 0.5-ms units) The packet interval can be set separately for each connection.

\*1 Unit version 2.0: 20 words (40 bytes) maximum.

### System Configuration Conditions for Setting Tags Using Symbols or I/O Memory Addresses

Local tags for tag data links can be set using I/O memory addresses or network symbols. Support for network symbols, however, depends on the model of CPU Unit, as shown in the following table.

Communications with the remote node are possible regardless of whether the remote node tags are set using I/O memory addresses or network symbols.

Name in hardware list of Network Configurator	CPU Unit	EtherNet/IP Unit or built-in EtherNet/IP port	Symbol name specification	I/O memory address specification
CJ2B-EIP21	CJ2H-CPU6□-EIP	CJ2H-CPU□□-EIP	OK	OK
CJ2M-EIP21	CJ2M-CPU3□	CJ2M-CPU3□	OK	OK
CJ1W-EIP21(CJ2)	CJ2H-CPU6□-EIP CJ2H-CPU6□ CJ2M-CPU3□ CJ2M-CPU1□	CJ1W-EIP21	OK (CJ2H-CPU6□-EIP and CJ2M-CPU3□ only) (See note.)	OK
CJ1W-EIP21	CJ1 CPU Unit	CJ1W-EIP21	---	OK
CS1W-EIP21	CS1 CPU Unit	CS1W-EIP21	---	OK

**Note** Symbols cannot be set for tags with CJ2H-CPU6□ and CJ2M-CPU1□ CPU Units.

## 6-1-4 Data Link Data Areas

### Tags

A data link between the local I/O memory and a remote I/O memory is called a tag. A tag can be set using a network symbol name or an I/O memory address.

### Tag Sets

When a connection is established, from 1 to 8 tags (including PLC status) is configured as a tag set. Each tag set represents the data that is linked for a tag data link connection. Tag data links are thus created by connecting one tag set to another tag set. A tag set name must be set for each tag set. Data is exchanged in the order that the tags are registered in the tag sets. The order of registration of the tags in the input tag sets and output tag sets must therefore be aligned.

**Note** A connection is used to exchange data as a unit within which data concurrency is maintained. Thus, data concurrency is maintained for all the data exchanged for the tags in one data set.

### Example

In the following example, input tags a to g at the originator are a tag set named SP1\_IN and output tags i and ii are a tag set named SP1\_OUT). A connection is set between these two tag sets.

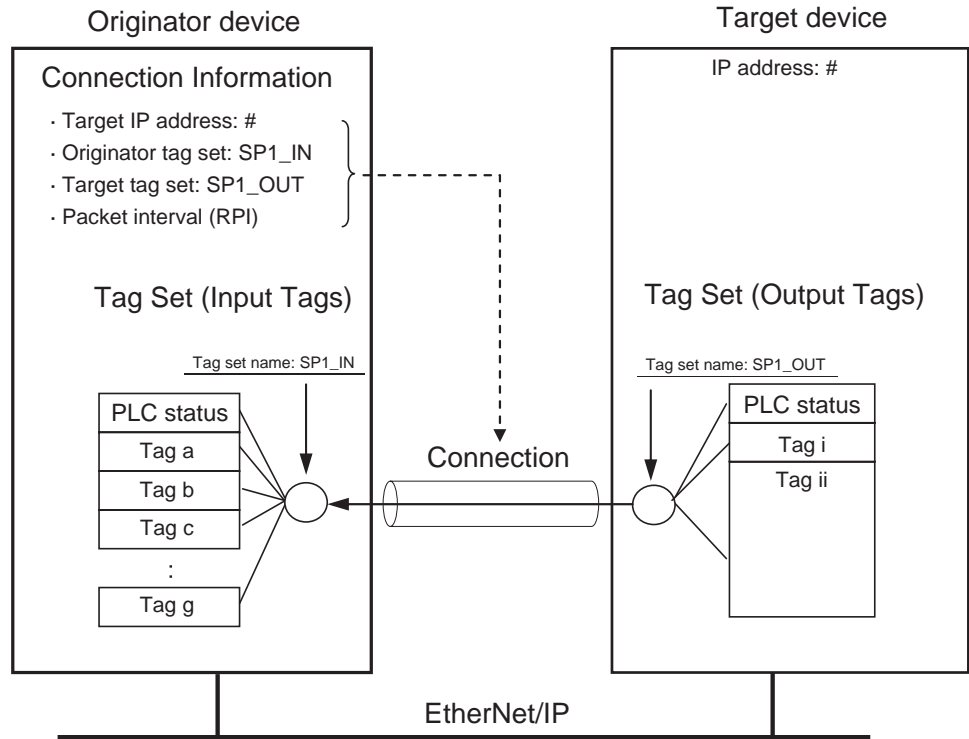

There are both input and output tag sets. Each tag set can contain only input tags or only output tags. The same input tag cannot be included in more than one input tag set.

**Number of Tags in Tag Sets**

Each tag set can contain one or more tags.

**Tag Sets with Only One Tag**

With basic Network Configurator procedures, each tag set contains only one tag.

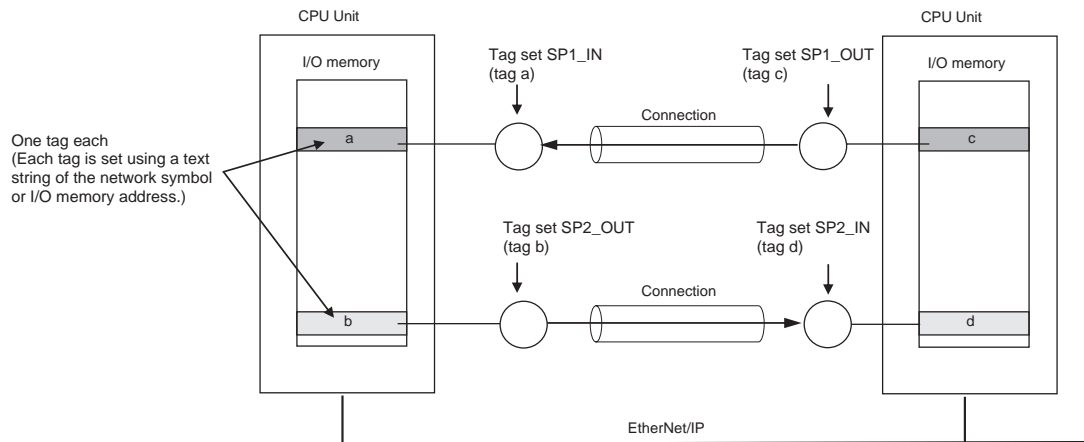

**Tag Sets with Multiple Tags**

As shown below, tags can be created in groups. Each tag set can contain up to 8 tags totaling 640 words for the CJ2M-EIP21 (20 words for unit version 2.0) or 722 words for other CPU Units.

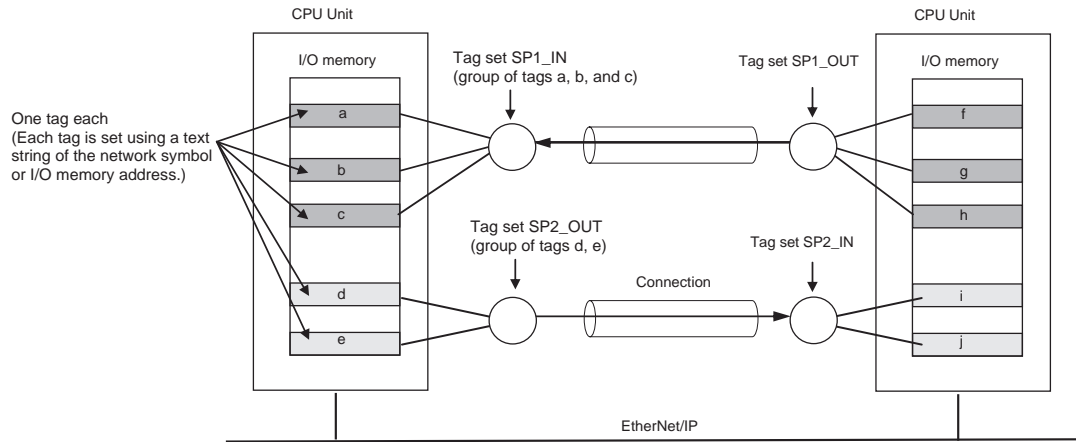

**Note** The I/O memory words used in tags in a tag set do not have continuous addresses. The tags can also be from different I/O memory areas. To enable a connection, however, each tag set must include only input tags or only output tags. (Both input and output tags cannot be included in the same tag set.)

**Specifications**

The following table shows the tag and tag set specifications.

Tags		Tag sets	
CS1W-EIP21 CJ1W-EIP21 CJ2H-CPU□□-EIP	CJ2M-CPU3□	CS1W-EIP21 CJ1W-EIP21 CJ2H-CPU□□-EIP	CJ2M-CPU3□
Total size of all tags ≤ 184,832 words	Total size of all tags ≤ 640 words	Maximum size of 1 tag set ≤ 722 words (The maximum size is 721 words when the tag set includes the PLC status.)	Maximum size of 1 tag set ≤ 640 words* <sup>1</sup> (The maximum size is 639 words when the tag set includes the PLC status.)* <sup>2</sup>
Maximum size of 1 tag ≤ 722 words (The maximum size is 721 words when the tag set includes the PLC status.)	Maximum size of 1 tag ≤ 640 words* <sup>1</sup> (The maximum size is 639 words when the tag set includes the PLC status.)* <sup>2</sup>	Number of tags per tag set ≤ 8 (7 tags/tag set when the tag set includes the PLC status) <b>Note</b> Input and output variables cannot be combined.	
Number of registrable tags ≤ 256	Number of registrable tags ≤ 32	Number of registrable tag sets ≤ 256	Number of registrable tag sets ≤ 32

\*1 Unit version 2.0: 20 words maximum.

\*2 Unit version 2.0: 19 words maximum.

**Note** Tag sizes can be set to odd numbers of bytes for any EtherNet/IP Units (or built-in EtherNet I/O ports) that were manufactured in October 2012 or later. However, the following precautions must be observed.

- I/O memory is consumed in units of words. Be sure that sufficient memory space is allocated.
- If you use variables to specify tags, specify any tag size with an odd number of bytes in bytes on the Network Configurator and then define the variable with a data size that is one byte larger as the size on the CX-Programmer.
- Do not use any EtherNet/IP Units (or built-in EtherNet/IP ports) that do not support tag sizes with an odd number of bytes.

**PLC Status**

A characteristic function of the CS1W-EIP21 and CJ1W-EIP21 EtherNet/IP Units and CJ2 built-in EtherNet/IP ports is the ability to specify the PLC status as a member of the tag set. This function reads the operating status (operating and error status) of the CPU Unit of the PLC in which the EtherNet/IP Unit is mounted, and includes the PLC status as status flags in the data transferred by the tag data links.

When the PLC status is specified as an output (produce) tag, it is actually transferred as the tag set's leading data in the following format.

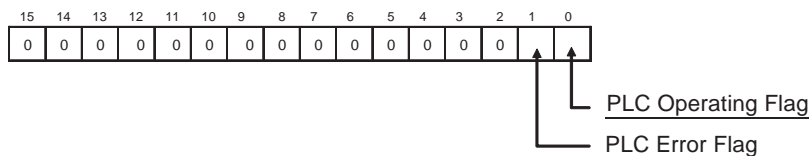

To receive the PLC status, specify the PLC status in an input (consume) tag in the reception tag set as well. When the PLC status is specified in an input tag, the PLC status flags will be reflected in the corresponding location in the tag data link's Target Node PLC Operating Flags and Target Node PLC Error Flags. The following example shows the relationship between the Target Node PLC Operating Flag location and target ID of the target node with 192.168.250.2.

IP address = 192.168.250.2 → (Last byte = 2) → Target ID = #002

**Target Node PLC Operating Flags:**

	15	14	13	12	11	10	9	8	7	6	5	4	3	2	1	0
n+2	15	14	13	12	11	10	9	8	7	6	5	4	3	2	1	0
n+3	31	30	29	28	27	26	25	24	23	22	21	20	19	18	17	16
n+4	47	46	45	44	43	42	41	40	39	38	37	36	35	34	33	32
n+5	63	62	61	60	59	58	57	56	55	54	53	52	51	50	49	48

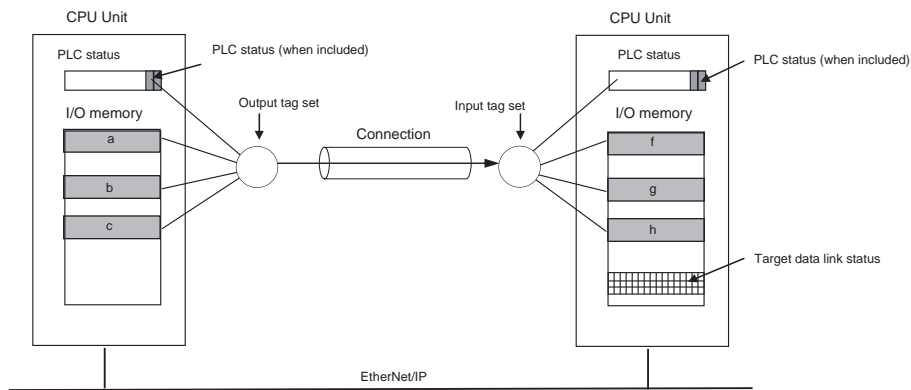

**Note** The target ID may be duplicated depending on the IP addresses of the target nodes. In this case, it is necessary to change the target ID with the Network Configurator. For information on how to change the device number, refer to step 4 under *Registering Devices in the Register Device List* on page 143.

The following table shows the operation of each the bits when multiple connections are used to communicate with a node, and the PLC status is specified in all of the connections.

Name (allocated area)	Contents
<p>Target Node PLC Operating Flag Information                      Layout set to default settings:                      Words n+2 to n+5                      Layout set to user settings:                      Words n+32 to n+47  <b>Note</b> Corresponds to the PLC status's PLC Operating Flag.</p>	<p>Each flag indicates the operating status of the corresponding target node PLC of connections in which the EtherNet/IP Unit is the originator. The flag corresponding to the target node's target ID will be ON when the PLC Operating Flags for all connections with that target node indicate that the PLC is operating.</p> <p>Each node address's flag location (i.e., target ID) can be changed from the Network Configurator.</p> <p>The PLC status flags are enabled when the PLC status is included in the communications data for both the originator and target.</p> <p>The data in this table is refreshed when necessary.</p>
<p>Target Node PLC Error Flag Information                      Layout set to default settings:                      Words n+6 to n+9                      Layout set to user settings:                      Words n+48 to n+63  <b>Note</b> Corresponds to the PLC status's PLC Error Flag.</p>	<p>Each flag indicates the error status (logical OR of non-fatal and fatal errors) of the corresponding target node PLC of connections in which the EtherNet/IP Unit is the originator. The flag corresponding to the target node's target ID will be ON if even one error is indicated in any of the connections with that target node.</p> <p>Each node address's flag location (i.e., target ID) can be changed from the Network Configurator.</p> <p>The PLC status flags are enabled when the PLC status is included in the communications data for both the originator and target.</p> <p>The data in this table is refreshed when necessary.</p>
<p>Normal Target Node Flag Table                      Layout set to default settings:                      Words n+20 to n+23                      Layout set to user settings:                      Words n+16 to n+31  <b>Note</b> Does not correspond to the PLC status.</p>	<p>Each flag indicates the connection status of the corresponding target node PLC of connections in which the EtherNet/IP Unit is the originator. The flag corresponding to the target node's target ID will be ON when connections are established for all connections with that target node indicate that the PLC is operating.</p> <p>Each node address's flag location (target ID) can be changed from the Network Configurator.</p> <p>The data in this table is refreshed when necessary.</p>

**Note** When the PLC status is not selected in the input (consume) tags, the PLC status information (16-bit data) can be used as reception data.

## 6-2 Setting Tag Data Links

### 6-2-1 Starting the Network Configurator

#### Procedure

Tag data links are set by using the Network Configurator. Use the following procedure to start the Network Configurator.

#### ■ Starting from the Windows Start Menu

To start the Network configurator, select **OMRON - CX-One - Network Configurator for EtherNet/IP - Network Configurator** from the Windows Start Menu.

#### ■ Starting from the IO Table Dialog Box in CX-Programmer

To start the Network configurator, select the Unit in the PLC IO Table Dialog Box and select either of the options for **Start Special Application** from the pop-up menu. Only operation will be started even if *Start with Settings Inherited* is selected.

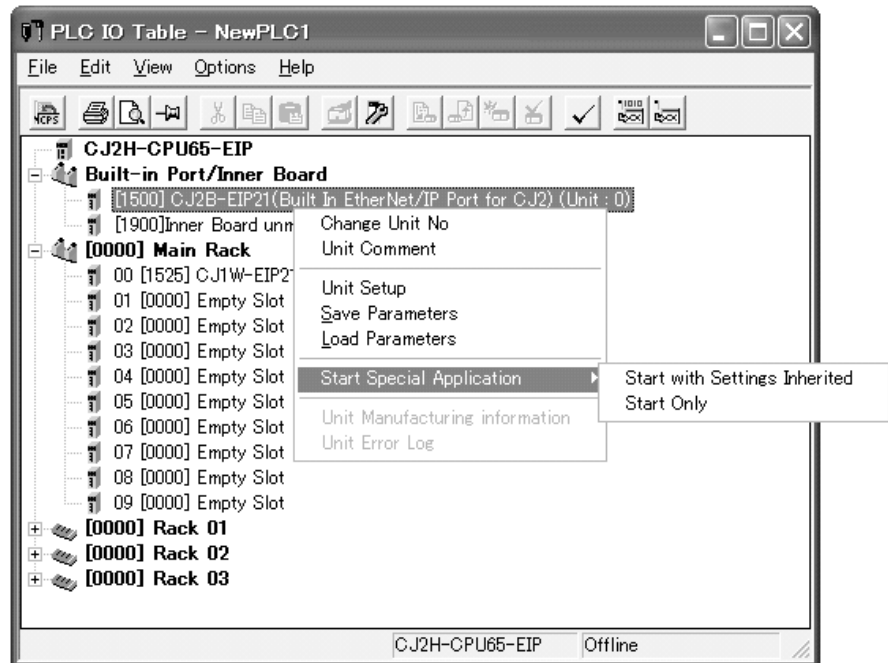

When the Network Configurator starts, the following window will be displayed.

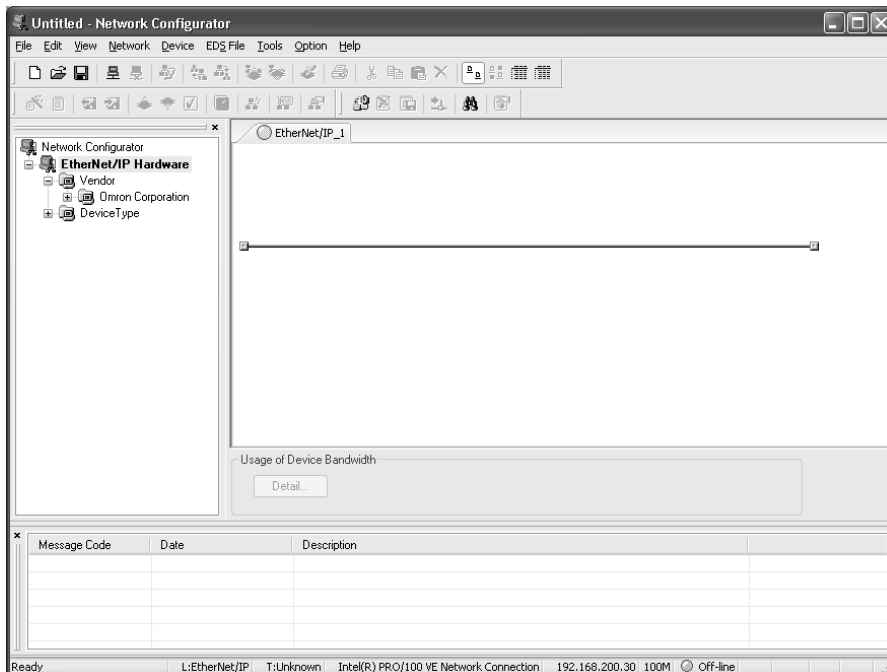

**Main Window**

The Main Window consists of a Hardware List and a Network Configuration Window, as shown in the following diagram.

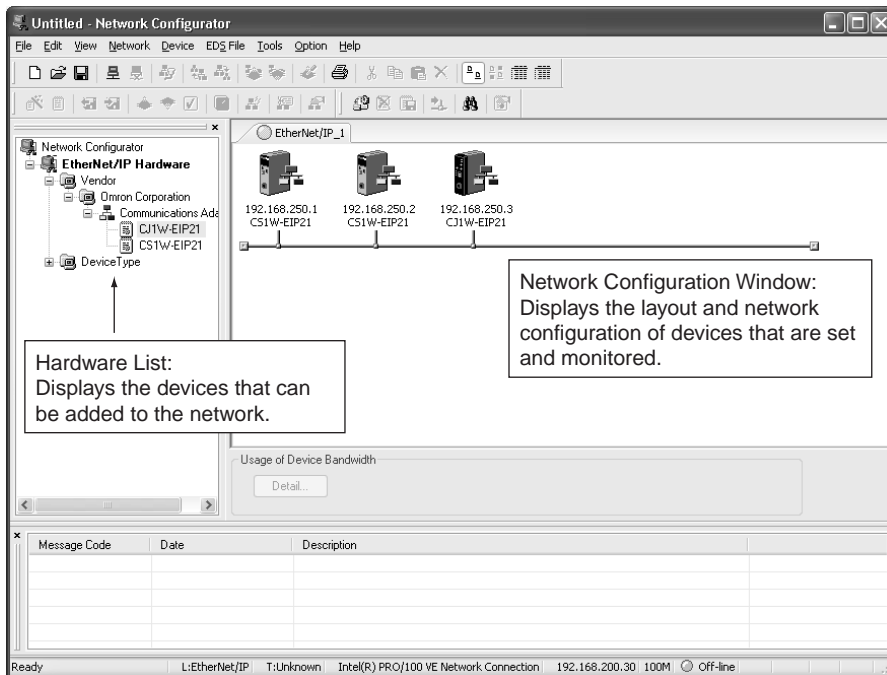



When two or more networks are being managed, a new Network Configuration Window can be added by selecting **Network - Add**.

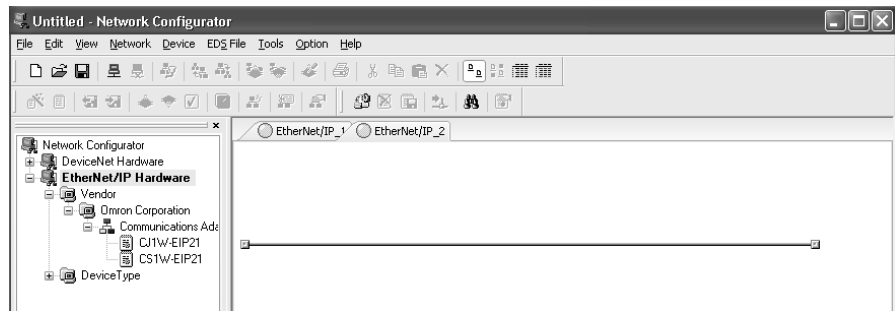

To change the name displayed in the Network Tab Page, select **Network - Property**. The name set in the *Comment* Field of the Network Property Window can be changed.

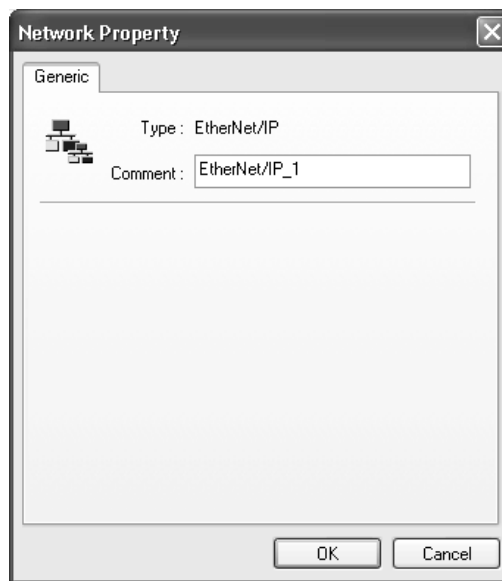

## 6-2-2 Tag Data Link Setting Procedure

The section describes the procedure for setting tag data links (i.e., connection information).

For data links between PLCs, the connection information is set only in the originator, i.e., the node that receives data.

### 1. Creating a Network Configuration

Register all EtherNet/IP Units or built-in EtherNet/IP ports for which connections will be created in the EtherNet/IP Network Configuration Window. (Refer to 6-2-3 *Registering Devices*.)

**Note** If a system has already been installed, connect online to the EtherNet/IP network and upload the network configuration. (Refer to 6-2-11 *Uploading Tag Data Link Parameters*.)



### 2. Creating Connections

Set the connections using one of the following methods.

#### 1) Basic Operation

1-1) Create tags and tag sets for all registered devices (EtherNet/IP Unit or built-in port). (Refer to 6-2-4 *Creating Tags and Tag Sets*.)

1-2) Create a connection for the originator device (i.e., registered device that receives data as input data). (Refer to 6-2-5 *Connection Settings*.)

#### 2) Generating a Connection Using the EtherNet/IP Datalink Tool (Refer to 6-2-5 *Connection Settings*.)

The EtherNet/IP Datalink Tool is used to create data links between PLCs by specifying I/O memory addresses in the same manner as for Controller Link. The following functions can be used with Network Configurator version 3.10 or higher.

#### 3) Creating Connections Using the Wizard (Refer to 6-2-7 *Creating Connections Using the Wizard*.)

Create connections between OMRON PLCs following the instructions. Tags and tag sets must be set for all devices before starting the Wizard. (Refer to *Basic Operation 1-1*.)

**Note** Select **Device - Parameters - Wizard** from the menus to start operation.

#### 4) Creating Connections by Dragging and Dropping Registered Devices (Refer to 6-2-8 *Creating Connections by Device Dragging and Dropping*.)

When a target device is dragged and dropped to the originator device, the Edit Connection Dialog Box will be displayed, and a connection can be created. OMRON EtherNet/IP Units or built-in EtherNet/IP ports are the only originator devices for which connections can be created in this way.



Downloading Tag Data Link Parameters (Refer to 6-2-10 *Downloading Tag Data Link Parameters*.)



Check that tag data links are operating correctly by using the indicators on the EtherNet/IP Unit (refer to 14-2 *Using the LED Indicators and Display for Troubleshooting for Troubleshooting*) and the Network Configurator monitor function (refer to 14-1 *Checking Status with the Network Configurator*).



Check that the output tag data is updated in the input tag by using the CX-Programmer's Watch Window or PLC memory function.

**Note** Refer to the *CX-Programmer Operation Manual* (Cat. No. W446) for the operating procedures.

**Note** The specifications for using tag data links with the CJ2M built-in EtherNet/IP port on a CJ2M-CPU3□ CPU Unit are different from the specifications for EtherNet/IP Units (CJ1W-EIP21 or CS1W-EIP21) and the CJ2H built-in EtherNet/

IP port on a CJ2H-CPU□□-EIP CPU Unit. Make sure you are using the correct specifications for the application.

Refer to 2-1-3 Communications Specifications for the communications specifications.

### 6-2-3 Registering Devices

Register all of the devices required in the equipment (such as EtherNet/IP Units performing tag data links) as a network configuration.

- 1,2,3...**
1. Register the devices that will participate in the tag data links by dragging the devices from the Hardware List and dropping them in the Network Configuration Window. (To drag and drop an icon, click and hold the left mouse button over the icon, move the icon to the destination, and release the mouse button.)  
The icon will be displayed in the Network Configuration Window, as shown in the following diagram.

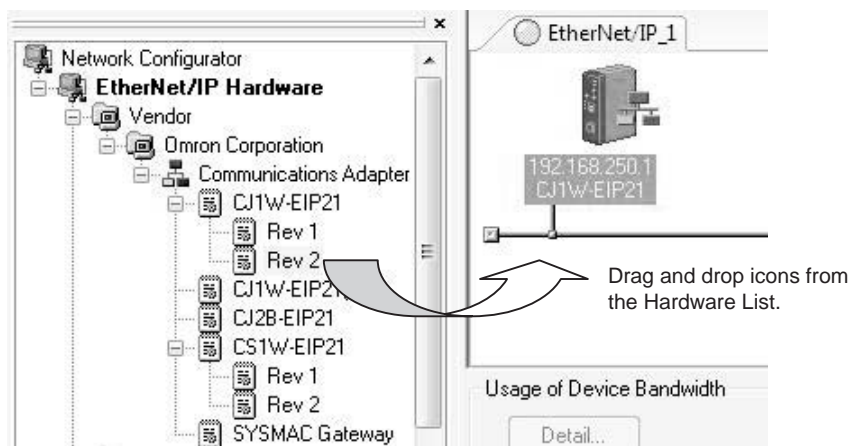

#### Hardware List

Name in hardware list	CIP revision	EtherNet/IP Unit
CJ2B-EIP21	Rev. 2	Built-in EtherNet/IP port on CJ2H CPU Unit (CJ2H-CPU□□-EIP)
CJ2M-EIP21	Rev. 2	Built-in EtherNet/IP port on CJ2M CPU Unit (CJ2M-CPU3□)
CJ1W-EIP21	Rev. 1 or 2	CJ1W-EIP21 EtherNet/IP Unit connected to CJ1 CPU Unit
CS1W-EIP21	Rev. 1 or 2	CS1W-EIP21 EtherNet/IP Unit connected to CJ1 CPU Unit
CJ1W-EIP21 (CJ2)	Rev. 2	CJ1W-EIP21 EtherNet/IP Unit connected to CJ2 CPU Unit

**Note** (1) If the revision is unknown, select the newest revision (i.e., the revision with the highest number). The following table shows the relation between the CIP revision and the unit version.

**CS1W-EIP21, CJ1W-EIP21, and CJ2H-CPU□□-EIP**

Unit version	CIP revision
Ver. 1.0	Revision 1.01
Ver. 2.0	Revision 2.01 to 2.03
Unit version 2.1	Revision 2.04 or 2.05

**CJ2M-CPU3□**

Unit version	CIP revision
Ver. 2.0	Revision 2.01
Ver. 2.1	Revision 2.02 or 2.03

- (2) When mounting the CJ1W-EIP21 to a CJ2 CPU Unit, select CJ1W-EIP21 (CJ2) from the Hardware List.
2. Click the right mouse button over the registered device's icon to display the pop-up menu, and select **Change Node Address**.



3. Set the IP address to match the node address (IP address) actually being used in the device.
4. Repeat steps 1 to 3, and register all of the devices participating in the tag data links.

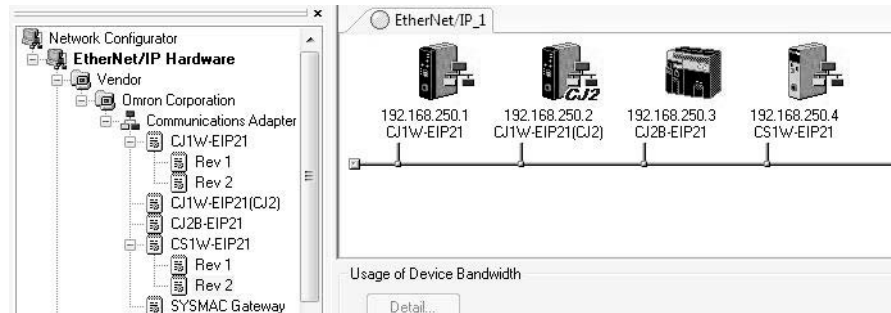

**6-2-4 Creating Tags and Tag Sets**

**Specifying I/O Memory Addresses**

The tag sets and set member tags required to create connections for a registered EtherNet/IP Unit must be created. The I/O memory addresses or network symbols that are used in the control programs can be set for the tags. (Using network symbols is supported only by the CJ2H-CPU6□-EIP21 and CJ2M-CPU3□.) This section first describes the basic procedure for creating tags and tag sets for using the Network Configurator's device parameter editing function.

1. Creating Tags and Tag Sets Using the Network Configurator's Device Parameter Editing Function
- Next, the following two procedures, which can be used to effectively use network symbols in tags, are described.
2. Importing Network Symbols Created with the CX-Programmer to the Network Configurator

3. Importing Network Symbols That Were Registered to Tags with the Network Configurator to the CX-Programmer

## 1. Creating Tags and Tag Sets Using the Network Configurator's Device Parameter Editing Function

**Note** The network symbols described in this section can be used only if you are using a CJ2H-CPU6□-EIP21 or CJ2M-CPU3□ CPU Unit.

### Creating a Tag Set

- 1,2,3... 1. Double-click the icon of the device (for which a tag set is being created) to display the Edit Device Parameters Dialog Box. Right-click the icon to display the pop-up menu, and select **Parameter - Edit**.

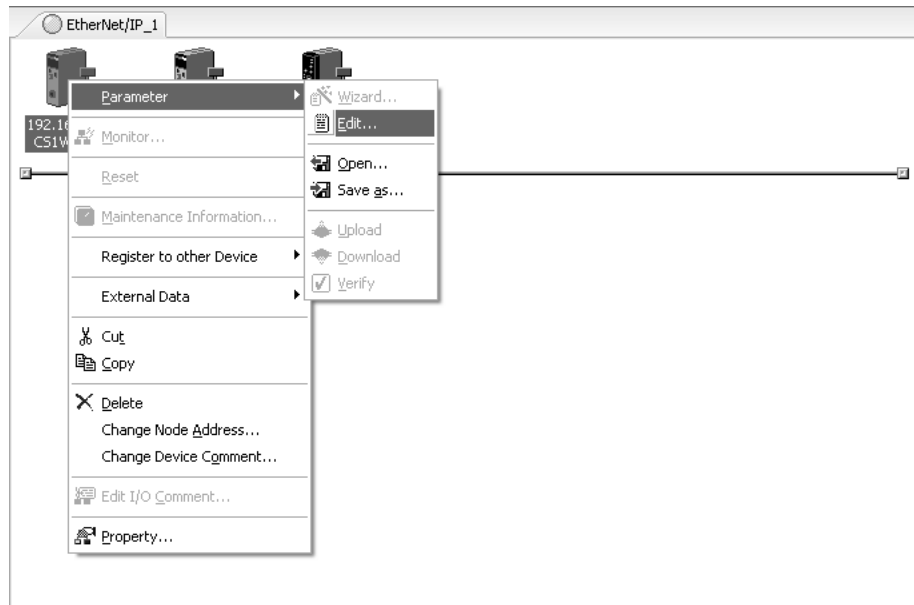

2. Click the **Tag Sets** Tab at the top of the Edit Device Parameters Dialog Box. There are two kinds of tag sets: input (consume) and output (produce).

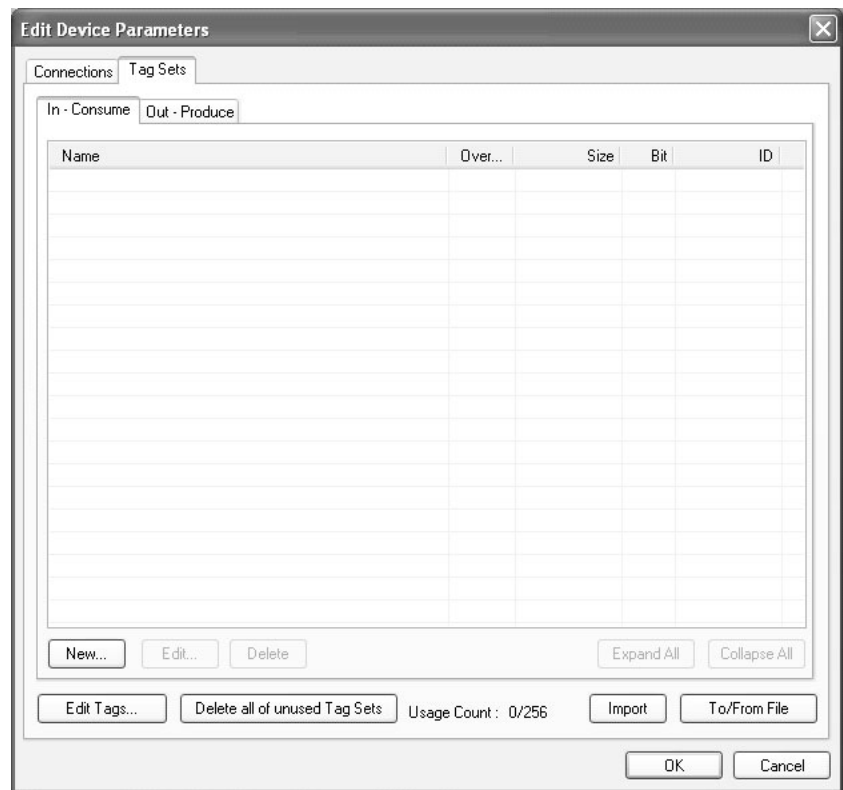

**Creating and Adding Tags**

3. Click the **Edit Tags** Button. The Edit Tags Dialog Box will be displayed. Register the input (consume) tags and output (produce) tags separately.

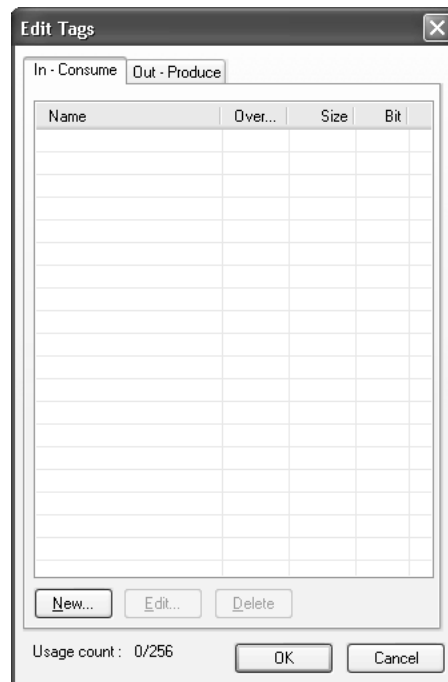

4. Click the **In - Consume** Tab, and click the **New** Button. The Edit Tag Dialog Box will be displayed.

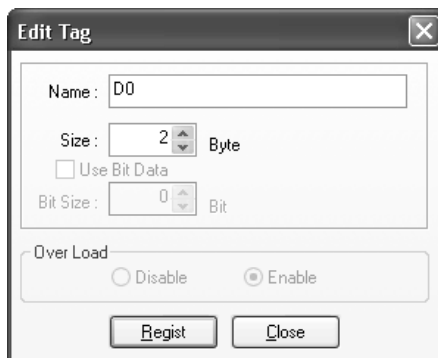

- In the Name Field, enter the character string for the CPU Unit's I/O memory address or a network symbol (e.g., 100, W100, D0, Input\_signal). Addresses in the following I/O memory areas can be set.

CPU Unit's data area		Address (Text to input in Name Field.)
CIO Area		0000 to 6143
Holding Area		H000 to H511
Work Area		W000 to W511
DM Area		D00000 to D32767
EM Area	Bank 0 hex	E0_00000 to E0_32767
	⋮	⋮
	Bank 18 hex	E18_00000 to E18_32767

**Note** (a) The H, W, D, and E characters can also be input in lower case as h, w, d, and e.

(b) Be sure to directly enter the CPU Unit's I/O memory address (e.g., 100, W100, D0) or a network symbol as a character string.

- Input the size of the tag in the *Size* Field, in bytes.
- Click the **Regist** Button to register the tag.  
If an I/O memory address is specified for a tag name, the Edit Tags Dialog Box will be displayed with the next consecutive address as the tag name for editing the next tag. Once you have registered the tags, click the **Cancel** Button.
- Click the **Out - Produce** Tab, and click the **New** Button. The Edit Tag Dialog Box will be displayed, like the dialog box for input tags, except for the *Over Load* setting. The *Over Load* setting determines whether outputs are cleared or continue their previous status when outputs are turned OFF with the PLC's Output OFF function. Output inhibit settings are not required for input (reception) tag sets.
  - Follow the output inhibit function: Enabled (default)  
Output data is cleared to 0 when a PLC output inhibit occurs.
  - Do not follow the output inhibit function: Disabled  
Output data maintains its previous status even after a PLC output inhibit occurs.

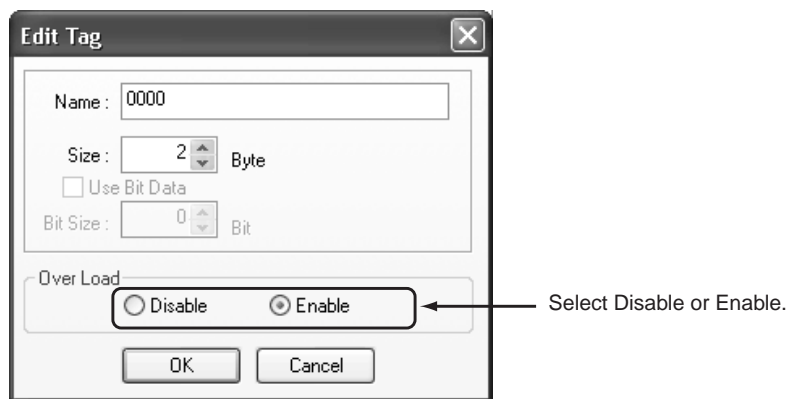

**Note** When any of the following errors occurs in the originator PLC while tag data links are in progress, the connection will be forcibly disconnected.

- Fatal CPU Unit error
  - I/O refreshing error
  - CPU Unit WDT error
  - I/O bus error
9. When you are finished registering the required tags, click the **OK** Button at the bottom of the Edit Tags Dialog Box.

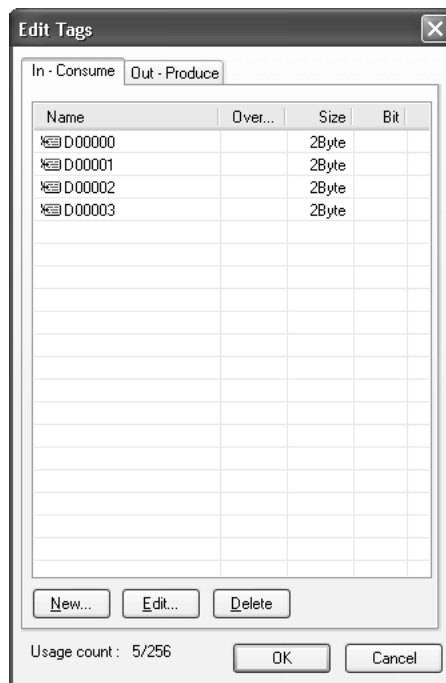

10. At this point, a confirmation dialog box will be displayed to check whether the registered tag names will be registered without changes as tag sets. A tag set can contain up to 8 tags, but tag sets will be registered with one tag per tag set if the tags are registered as tag sets. In this case, the **Yes** Button is clicked to register one tag per tag set.







If the **No** Button is clicked, more tags can be registered at the end of the tag set. Refer to step 18 for details on adding tags to the end of the tag set.

**Changing and Registering Tag Sets**

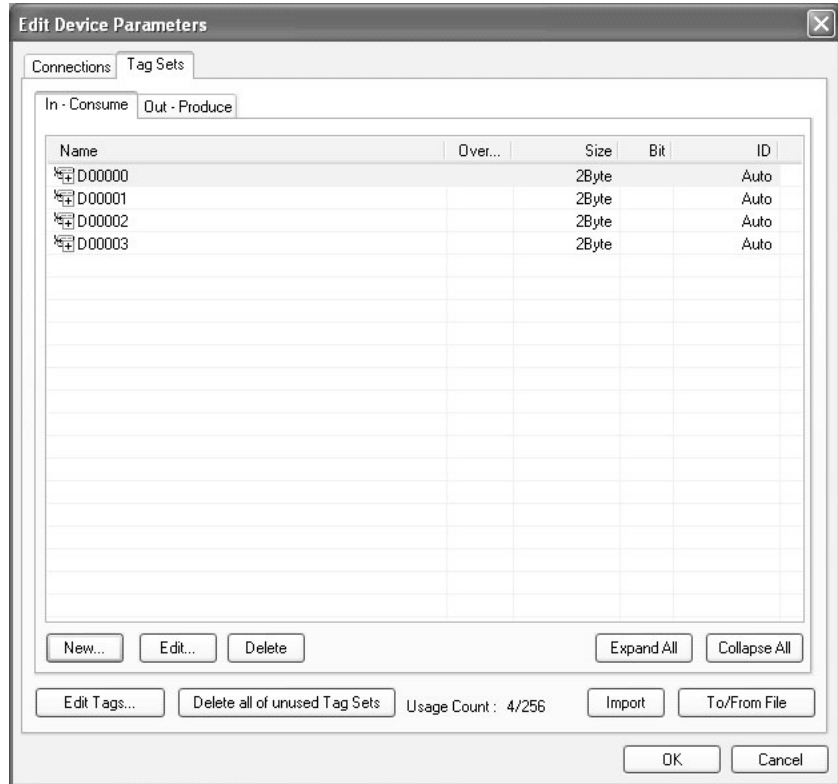
11. The following dialog box will be displayed when the tags in the Edit Tags Dialog Box are registered directly as tag sets.



12. If an input tag has already been registered in an input tag set, and you want to change its registration to a different input tag set, it is necessary to delete the tag from the tag set in which it was originally registered.

Open the Edit Device Parameters Dialog Box, select the tag set containing the tag that you want to delete, and click the **Delete** Button in the Edit Tag Dialog Box. (If there are other tags registered in that tag set, it is possible to delete just one tag by selecting the tag that you want to delete in the Edit Tag Set Dialog Box and clicking the  Button.)

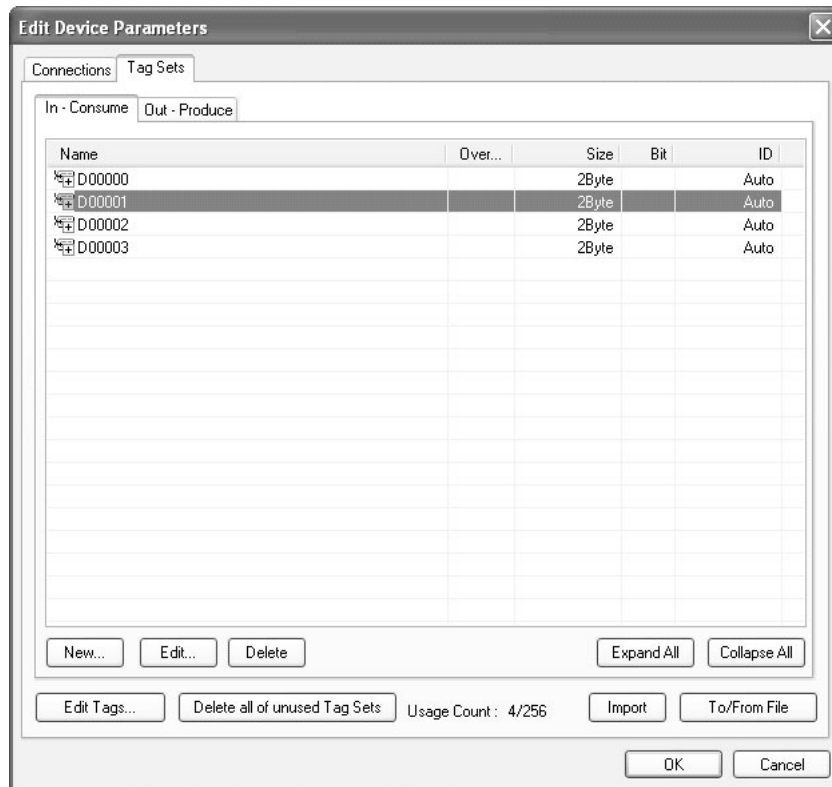

At this point, a confirmation dialog box will be displayed to confirm that you want to delete the selected tag set and the tags contained in that tag set.



If the **No** Button is clicked, only the tag set will be deleted. Click the **No** Button.

13. In order to edit a registered tag set and add tags, either double-click the tag set, or select the tag set and click the **Edit** Button. The Edit Tag Set Dialog Box will be displayed.

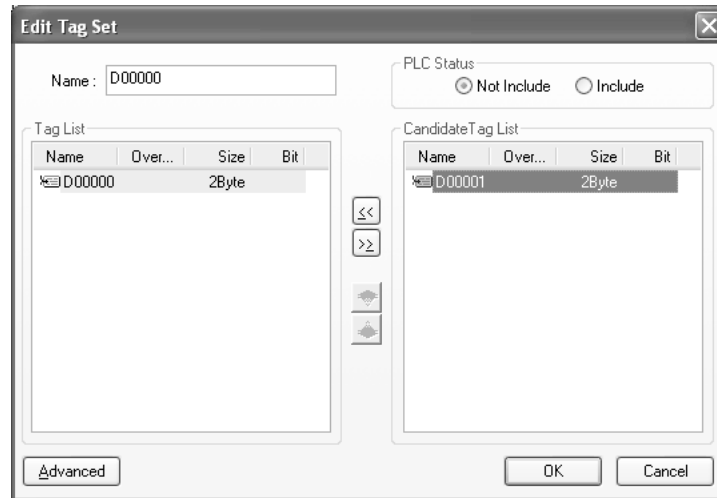

The *Tag List* on the left side of the dialog box shows the tags that are already registered, and the *Candidate Tag List* on the right side of the dialog box shows the other tags that have not been registered yet. To add a tag, select it in the *Candidate Tag List* and click the Button.

14. When the PLC status is being included in the tag set, select the *Include* Option at the upper-right corner of the dialog box.



15. If you want to change the tag set's name, it can be changed in this dialog box.
16. To save the changes, click the **OK** Button at the bottom of the Edit Tag Set Dialog Box.
17. Click the **OK** Button at the bottom of the Edit Device Parameters Dialog Box.

18. If you want to just add new tags and register the tag set, first register the tags with steps 1 to 9. In this example, input tags D00004 and D00005 have been newly added.

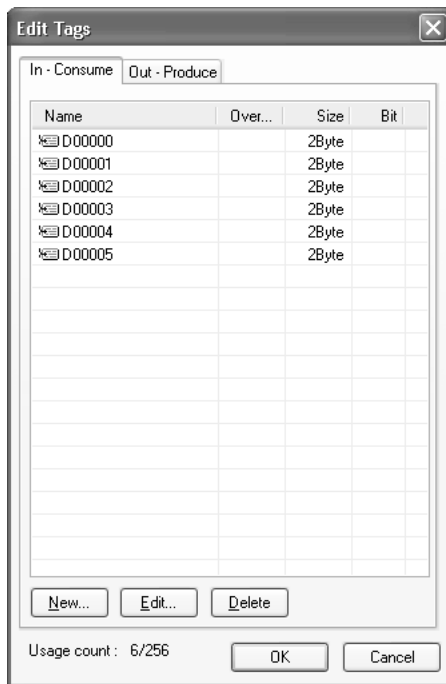

19. When you are finished registering the required tags, click the **OK** Button at the bottom of the Edit Tags Dialog Box.
20. At this point, a confirmation dialog box will be displayed to check whether the registered tag names will be registered without changes as tag sets. Tags are just being added in this case, so click the **No** Button. Just the tags will be registered, without registering the tags as tag sets.



21. To register the newly added tags in a tag set, either double-click the desired tag set, or select the tag set and click the **Edit** Button.

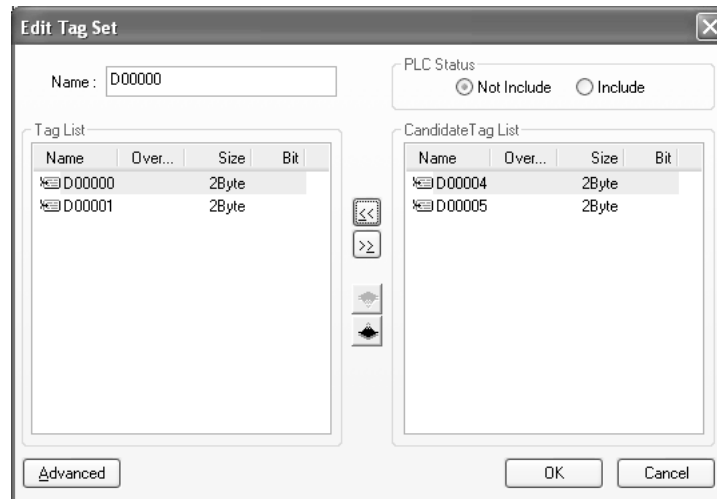

The *Tag List* on the left side of the dialog box shows the tags that are already registered, and the *Candidate Tag List* on the right side of the dialog box shows the other tags that have not been registered yet.

22. Select the tags that you want to add from the *Candidate Tag List* and click the << Button.

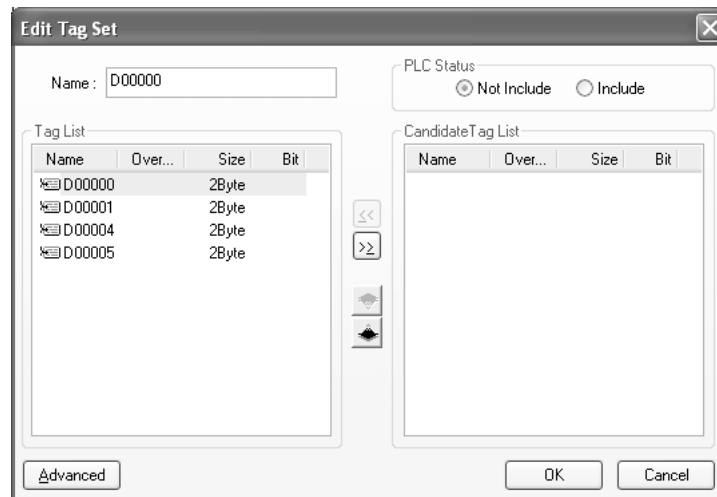

Up to 8 tags can be registered in a tag set, or up to 7 tags can be registered and two bytes will be added to the size if the PLC status is included in the tag set.

23. To confirm the changes, click the **OK** Button at the bottom of the Edit Tag Set Dialog Box.
24. Click the **OK** Button at the bottom of the Edit Device Parameters Dialog Box.

## 2. Importing Network Symbols Created with the CX-Programmer to the Network Configurator

If the CJ2H-CPU6□-EIP or CJ2M-CPU3□ is used, you can create network symbols using the CX-Programmer, import them into the Network Configurator, and then create tags and tag sets. Use the following procedure.

### Creating Global Symbols

Create global symbol with the Global Symbol Editor of the CX-Programmer and select *Input* or *Output* for the network variable properties. Save the project when you are finished.

Any global symbols with *Input* or *Output* set for the network variable property will be imported when the import procedure is performed from the Edit Device Parameters Dialog Box.

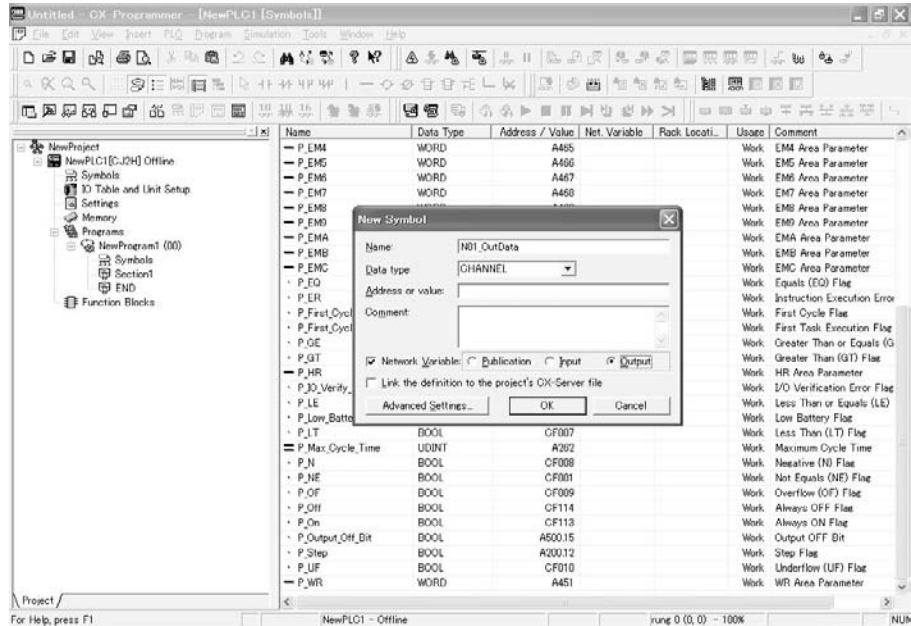

### Importing Symbols to the Network Configurator

1,2,3...

#### Note

1. Start the CX-Programmer and open the project that was saved.
2. From the devices registered in the Network Configurator, double-click the icon of the device for which to import the network symbols. The Edit Device Parameter Dialog Box will be displayed. You can also right-click the icon and select **Device - Parameters - Edit** from the pop-up menu.
3. Click the **Import** Button on the Tag Sets Tab Page of the Edit Device Parameter Dialog Box.

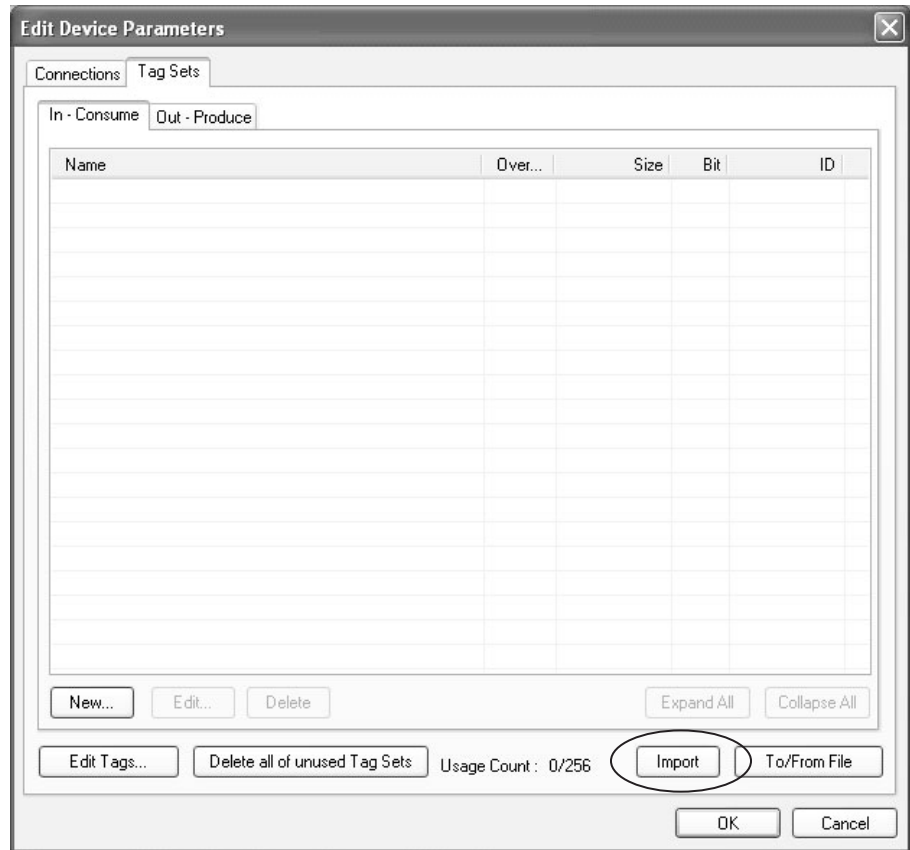

A confirmation message will be displayed. Click the **Yes** Button.

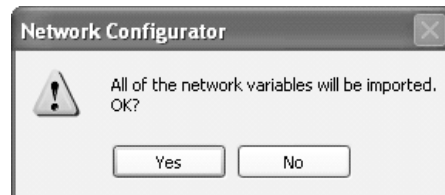

The symbols will be imported as shown below on the Tag Sets Tab Page. Each symbol will be imported into a different tag set and the device parameters will be automatically edited. (The symbol name will be used for the tag set name.)





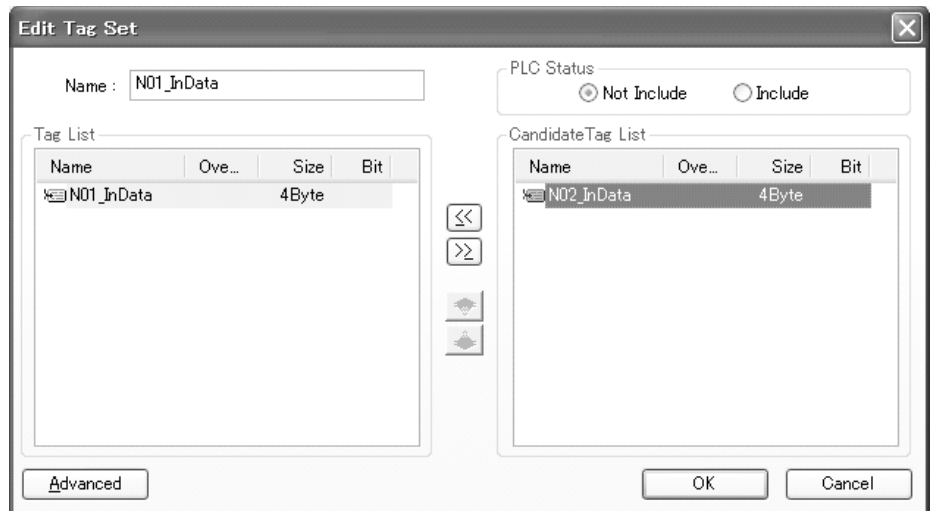

4. You can change tag set names in this dialog box. To confirm a change, click the OK Button in the dialog box.
5. Perform steps 1 to 3 for all the devices that will perform tag data links.

### 3. Importing Network Symbols That Were Registered to Tags with the Network Configurator to the CX-Programmer

If the CJ2H-CPU6□-EIP or CJ2M-CPU3□ is used, you can specify network symbols for tags using the Network Configurator. The procedure to import network symbols that were created using the Network Configurator into the CX-Programmer is described below.

#### Exporting Tags and Tag Sets with the Network Configurator

- 1,2,3... 1. Select **To/From File - Export to file** on the Tag Sets Tab Page in the Edit Device Parameters Dialog Box to export the tag and tag set information to a CSV file.

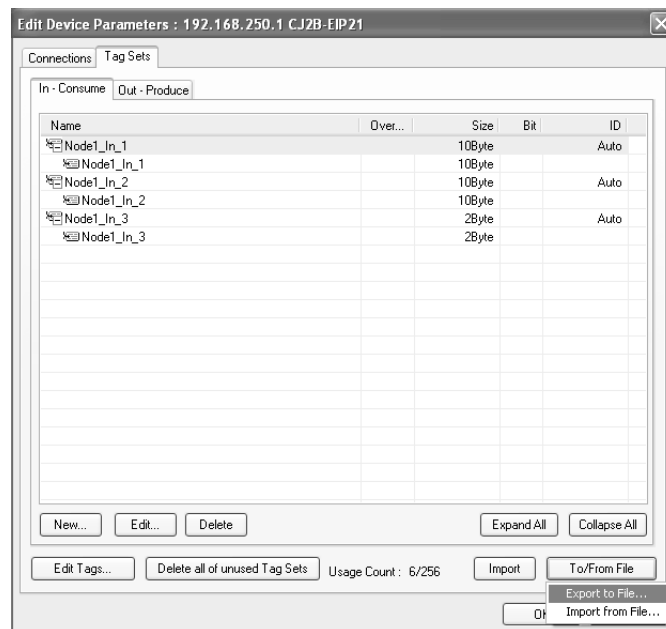

Importing the Tag and Tag Set CSV File with the CX-Programmer

- 1,2,3... 1. In the project global symbol table for the CJ2H-CPU6□-EIP or CJ2M-CPU3□, right-click and select **Import Network Variable** from the pop-up menu.

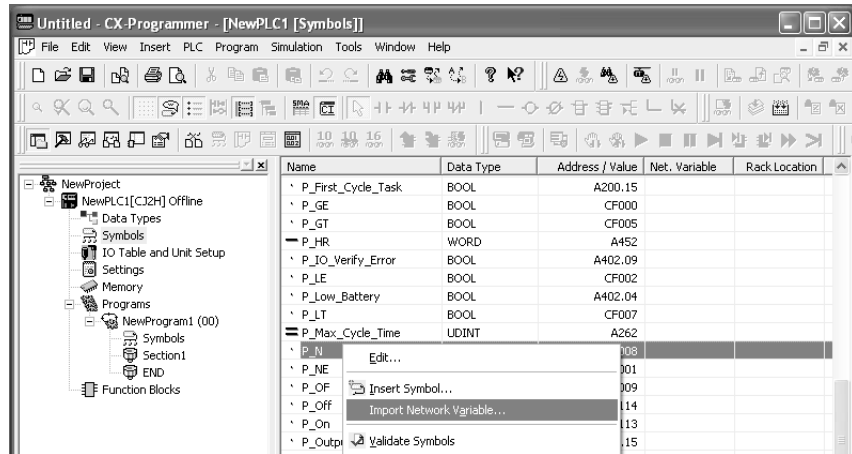

2. You can add a tag as a network symbol by selecting and executing the CSV file exported using the Network Configurator.

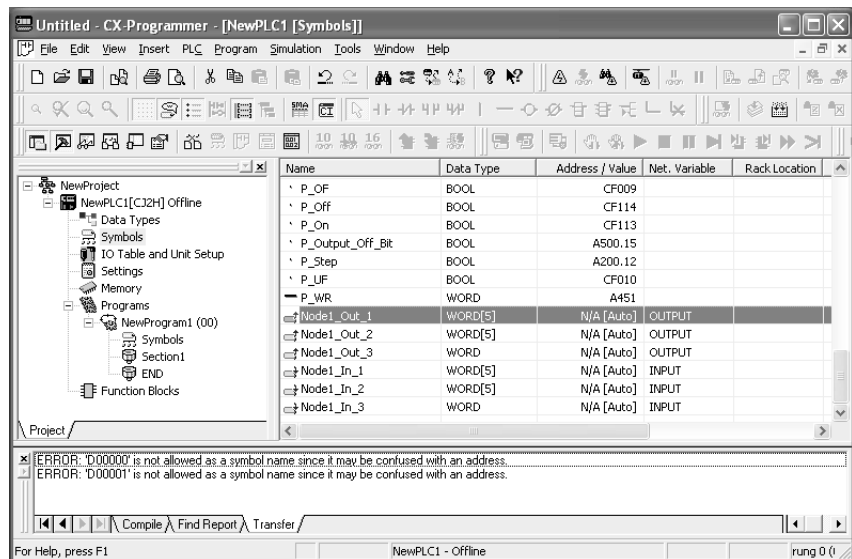

**Note** The following precautions apply when importing.

- Tags that have a specified I/O memory address cannot be imported.
- Tags are imported as network symbols in a one-dimensional WORD array. To change the data type, use the Symbol Editor of the CX-Programmer.

## 6-2-5 Connection Settings

After creating the tag sets, click the **Connections** Tab at the top of the Edit Device Parameters Dialog Box, and set the following connection information.

- The target devices with which connections will be opened
- Whether the tag sets are input or output tag sets
- The length of the packet intervals (RPI)

Make the Connections settings in the originator only. The Connections settings are not necessary in the target device.

**Note** Make the Connections settings after creating tag sets for all of the devices involved in tag data links.

### Connection Settings (Connections Tab)

#### Registering Devices in the Register Device List

- 1,2,3... 1. Display the originator device's Edit Device Parameters Dialog Box by double-clicking the device's icon in the Network Configuration Window, or right-clicking the device's icon and selecting **Parameter - Edit** from the pop-up menu.
2. Click the **Connections** Tab at the top of the Edit Device Parameters Dialog Box. All of the devices registered in the network (except the local node) will be displayed.

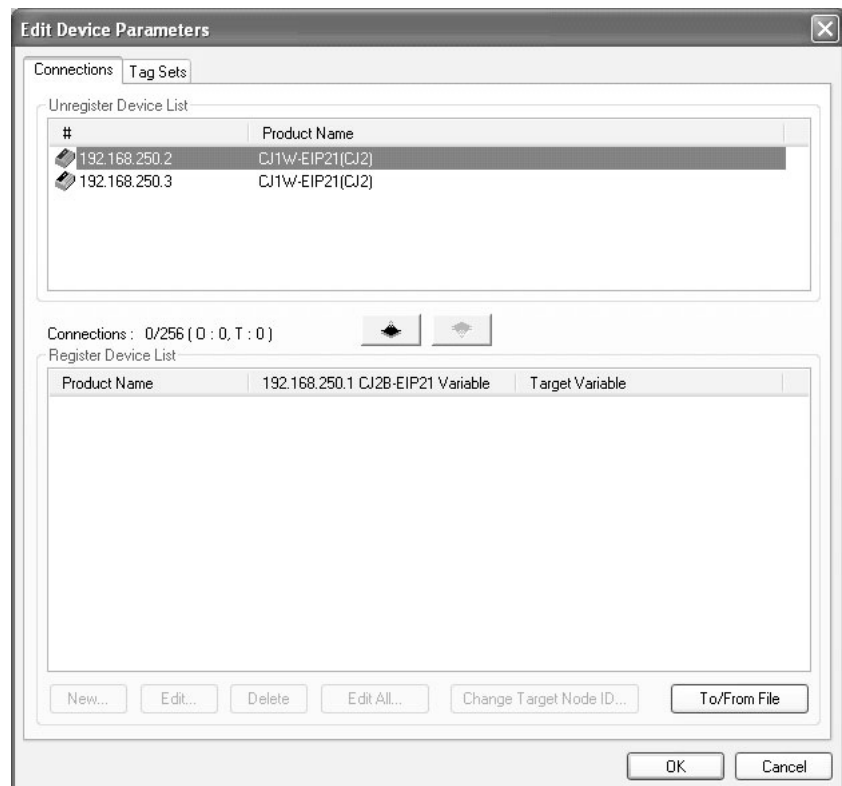

- In the Unregister Device List, select the target device that requires connection settings by clicking the device so its color changes to gray, and click the  Button. The selected target device will be displayed in the Register Device List, as shown in the following diagram.

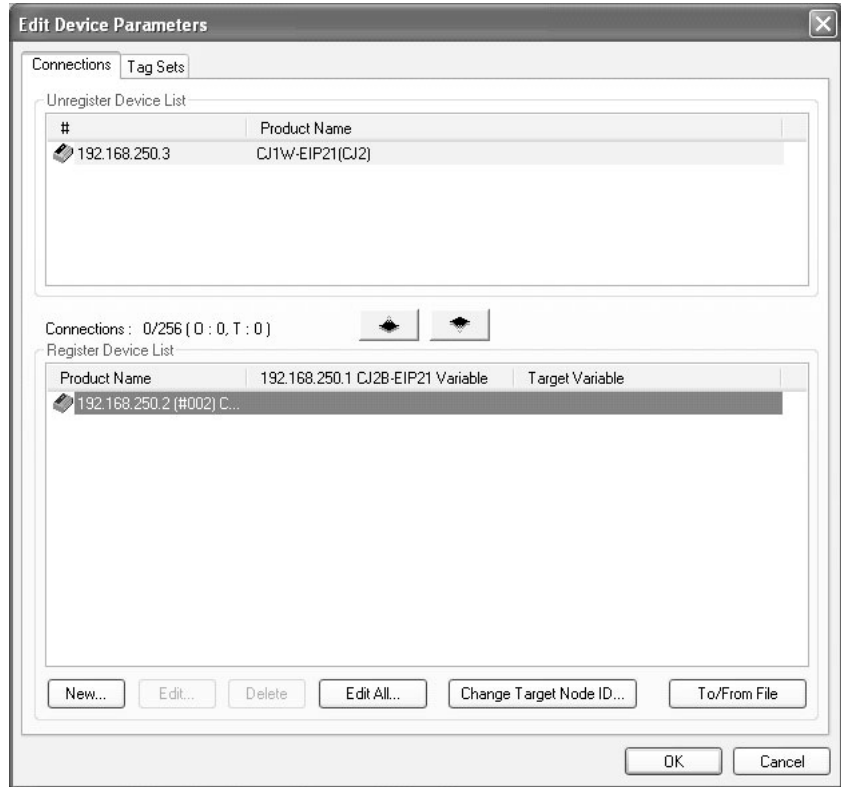

- Target node IDs are assigned to devices registered in the Register Device List. This target node ID determines the location in the originator node PLC of the Target Node PLC Operating Flag, Target Node PLC Error Flag, Registered Target Node Flag, and Normal Target Node Flag. By default, the target ID is automatically set to the rightmost 8 bits of the IP address. In the example above, the target device's IP address is 192.168.250.2, so the device number is #002. If a target node ID is duplicated and you want to change the device number, click the **Change Target Node ID** Button and change the target ID.

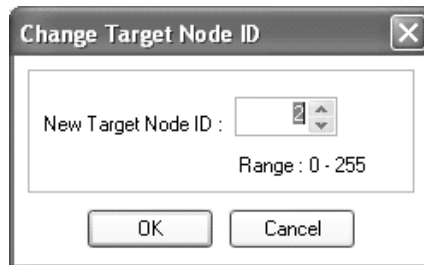

**Editing Settings for Individual Connections**

You can edit each connection separately.

**Note** Refer to the following page for information on how to perform batch editing in a table format.

- 1,2,3... 1. Select the **Connection** Tab and then click the **New** Button.  
The following Edit Connection Dialog Box will be displayed according to the type of device that is selected.

**Using an OMRON EtherNet/IP Unit or Built-in EtherNet/IP Port as the Target**

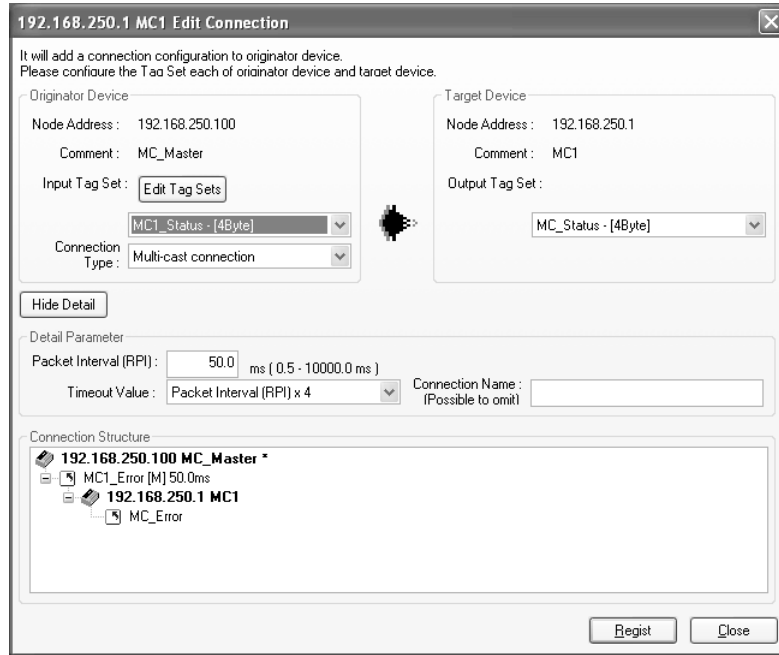

**Using Other EtherNet/IP Devices as the Target**

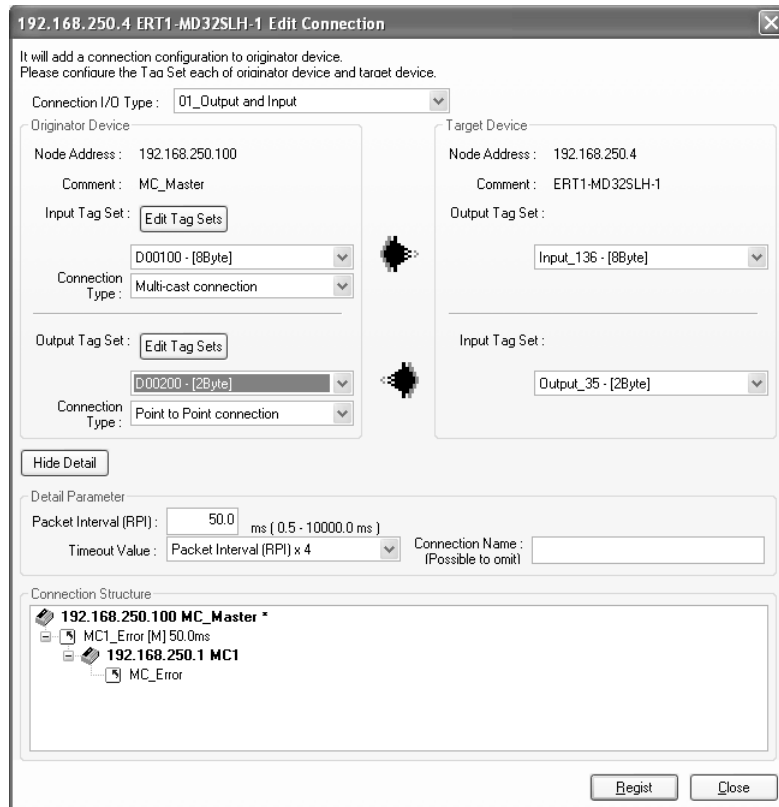

The settings are as follows:

Item	Description
Connection I/O Type	When creating tag data links for a CS1W-EIP21, CJ1W-EIP21, CJ2B-EIP21, or CJ2M-EIP21, select <i>Input Only (Tag Type)</i> . When creating tag data links for other target devices, select the connection I/O type specified in that device's EDS file. Use the <i>Input Only (ID type)</i> setting when another company's node is the originator and does not support connection settings with a Tag type setting.
Connection Type	Selects whether the data is sent in multicast or unicast (point-to-point). The default setting is multicast. <ul style="list-style-type: none"> <li>• Multicast connection Select this type when the same data is shared by multiple nodes. This setting is usually used.</li> <li>• Point-to-Point connection Select this type when the same data is not shared by multiple nodes. In a unicast connection, other nodes are not burdened with an unnecessary load.</li> </ul> <p><b>Note</b> Refer to 6-1-2 <i>Overview of Operation</i> for details on using multicast and unicast connection as well as counting the number of connections.</p>
The <i>Connection Structure</i> Field and the following items will not be displayed if the <b>Hide Detail</b> Button is pressed.	
Packet Interval (RPI)	Sets the data update cycle (i.e., the packet interval) of each connection between the originator and target. The interval can be set to between 1 and 10,000 ms for the CJ2M-EIP21 and 0.5 and 10,000 ms for other CPU Units in 0.5-ms increments. The default setting is 50 ms (i.e., data updated once every 50 ms).
Timeout Value	Sets the time until a connection times out. The timeout value is set as a multiple of the packet interval (RPI) and can be set to 4, 8, 16, 32, 64, 128, 256, or 512 times the packet interval. The default setting is 4 times the packet interval (RPI).
Connection Name	Sets a name for the connection. (32 characters max.)

- When the settings have been completed, press the **Regist** Button.

**Connections Settings  
(Editing All Connections)**

The connection settings between the originator and all of the target devices selected in the Register Device List can be edited together in a table.

1,2,3...

- Select the **Connections** Tab, and click the **Edit All** Button. The following Edit All Connections Dialog Box will be displayed.

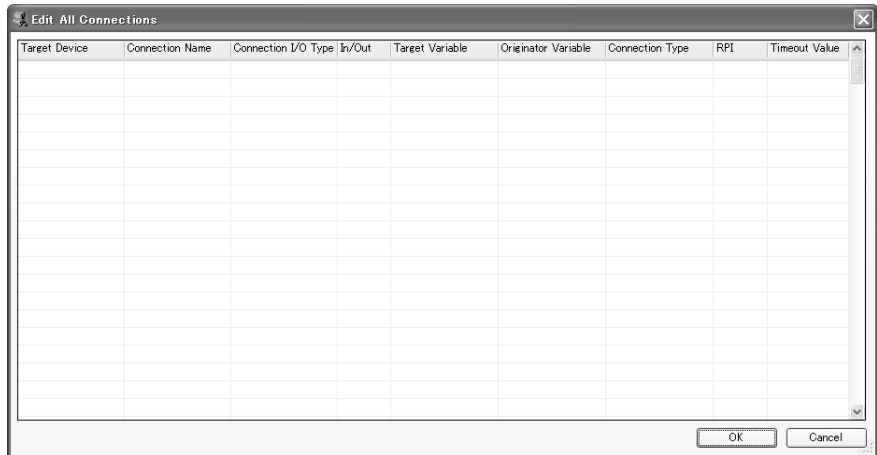

The following table describes the various settings in the dialog box.

Setting	Function
Target Device	Selects the target device.
Connection Name	Any name can be given to the connection (up to 32 characters). If this field is left blank, a default name will be assigned. This Connection Name can be used for comments.
Connection I/O Type	When making tag data links in a CS1W-EIP21, CJ1W-EIP21, CJ2B-EIP21, or CJ2M-EIP21, select <b>Input Only (Tag type)</b> . When making tag data links in other devices, select the connection I/O type specified in that device's EDS file. Use the <b>Input Only (ID type)</b> setting when another company's node is the originator and does not support connection settings with the <b>Tag type</b> setting.
In/Out	The connections I/O is automatically displayed based on the selected connection. • Input Only: Just <i>In</i> is displayed.
Target Variable	Selects and allocates the target node's tag set. • In: Selects the target's output (produce) tag set. • Out: Selects the target's input (consume) tag set.
Originator Variable	Selects and allocates the originator node's tag set. • In: Selects the originator's output (produce) tag set. • Out: Selects the originator's input (consume) tag set.
Connection Type	Selects whether the data is sent in a multicast or unicast. The default setting is multicast. • Multicast connection: Select when the same data is shared by multiple nodes. This setting is usually selected. • Point-to-Point connection: Select when the same data is not being shared by multiple nodes. In a unicast transmission, other nodes are not burdened with an unnecessary load. <b>Note</b> Refer to 6-1-2 <i>Overview of Operation</i> for details on using multicast and unicast transmissions, and counting the number of connections.
RPI	Sets the packet interval (RPI) of each connection between the originator and target. The interval can be set between 1 and 10,000 ms for the CJ2M-EIP21 and 0.5 and 10,000 ms for other CPU Units in 0.5-ms units. The default setting is 50 ms (data refreshed once every 50 ms).
Timeout Value	Sets the time until a connection timeout is detected. The time out value is set as a multiple of the packet interval (RPI) and can be set to a 4, 8, 16, 32, 64, 128, 256, or 512 multiple. The default setting is 4× the packet interval (RPI).

- When the settings are completed, click the **OK** Button.

**Confirming the Connections Settings**

- 1,2,3... 1. An overview of the connections set in the Register Device List is displayed in the Connections Tab Page.

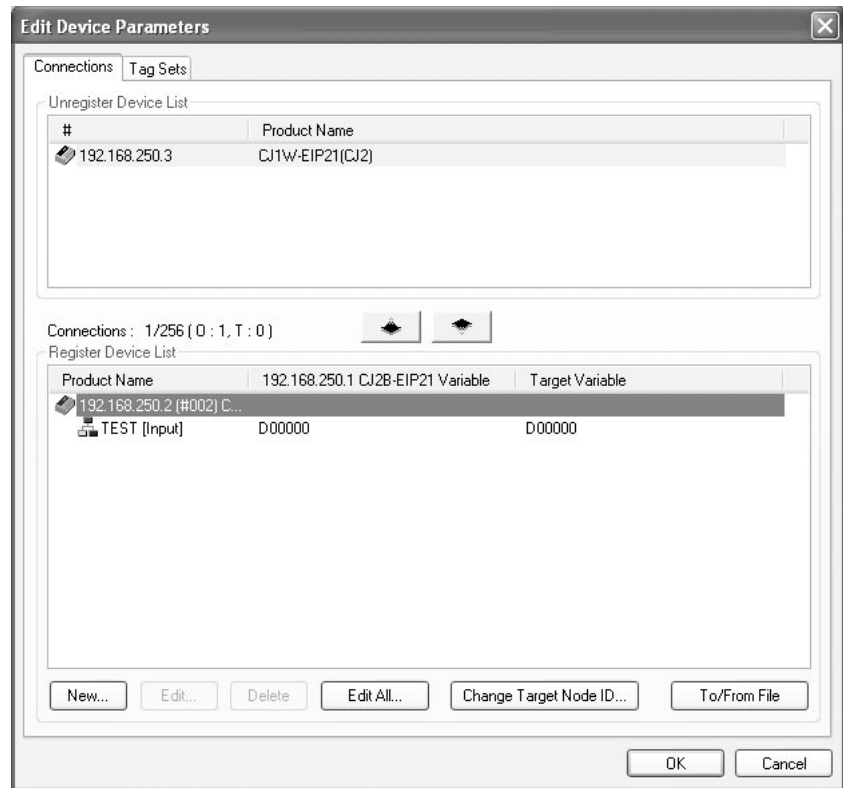

2. Click the **OK** Button. The following kind of diagram will be displayed.

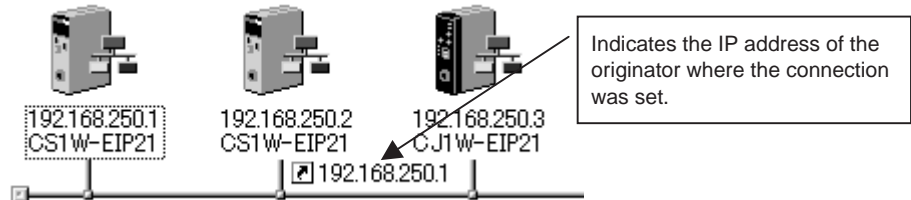

3. Repeat the Connections setting procedure until all of the connections have been set.

**Note** After completing the settings, always click the **OK** Button before closing the Edit Device Parameters Dialog Box and performing another operation. If the **Cancel** Button is clicked and the dialog box is closed, the new settings will be discarded.



4. If the tag set's size is changed in either the originator or target after the connection was set, the size will not match the other node and a parameter data mismatch will occur. In this case, if the connection settings have been changed, be sure to check the connections. (*Refer to 6-2-17 Checking Connections.*)

**Automatically Setting Connections**

Tag set names set for devices can be automatically detected to automatically set connections between input and output tag sets with the same name (or the same names excluding specified ellipses). Connections are automatically set under the following conditions.

Output tag set names	Except for specified ellipses, the output tag set name must be the same as the input tag set name. Ellipses can be set for the beginning or end of tag set names.
Input tag set names	Except for specified ellipses, the input tag set name must be the same as the output tag set name. Ellipses can be set for the beginning or end of tag set names.
Connection types	The connection type must be <i>Input Only</i> . Multicast and single cast connection types can be specified when executing a connection.
RPI	The default setting is used.
Timeouts	The default setting is used.

**Example 1: Automatic Connections with the Same Tag Set Names**

The following connections would automatically be set if there is an output tag set named A\_Signal at node A and input tag sets named A\_Signal at nodes B and C.

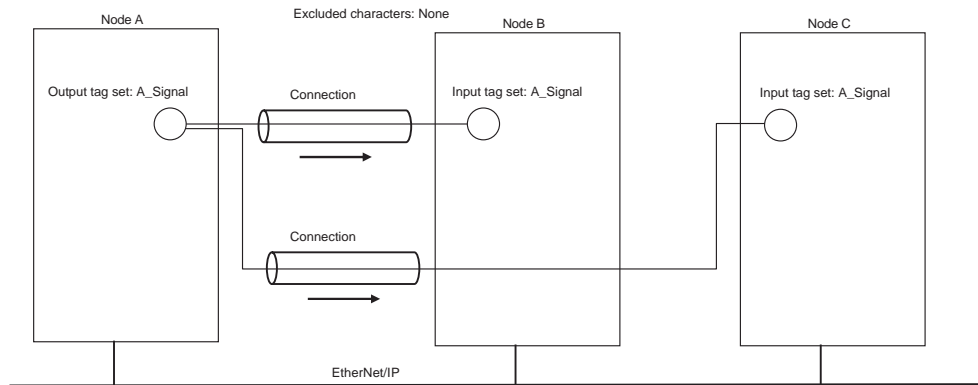

**Example 2: Automatic Connections with the Ellipses**

The following connections would automatically be set if there is an output tag set named O\_Signal at node A and input tag sets named I\_Signal at nodes B and C, and "O\_" and "I\_" were set as ellipses.

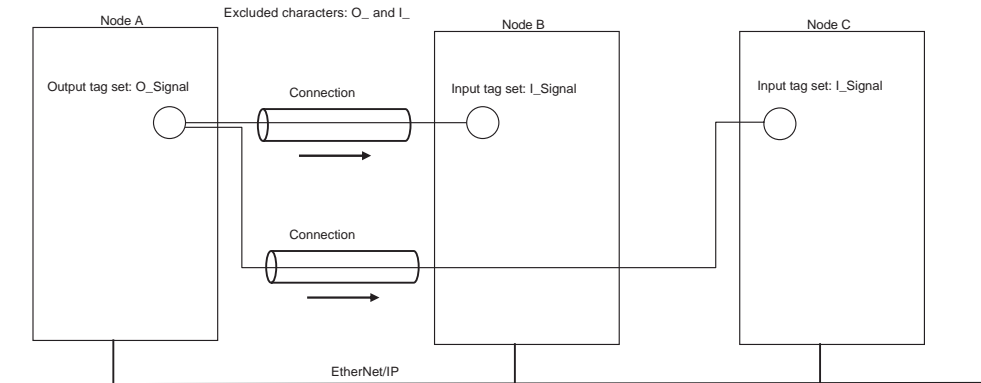

- 1,2,3...**
1. Set the same tag set names for the output and input tag sets for the connection. The tag set names can also include forward and backward ellipses.
  2. Select **Auto Connection** from the Network Menu. The connections will be set automatically.  
A dialog box will appear to set forward and backward ellipses for both output (produce) and input (consume) tag sets as soon as automatic connection setting processing has begun.

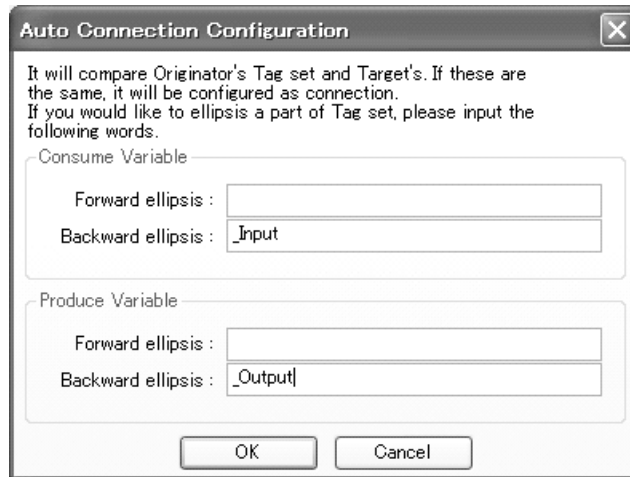

Input the ellipses and click the **OK** Button. Automatic setting will be processed.

3. If there are tag sets that meet the conditions for automatic connection setting, they will be displayed.



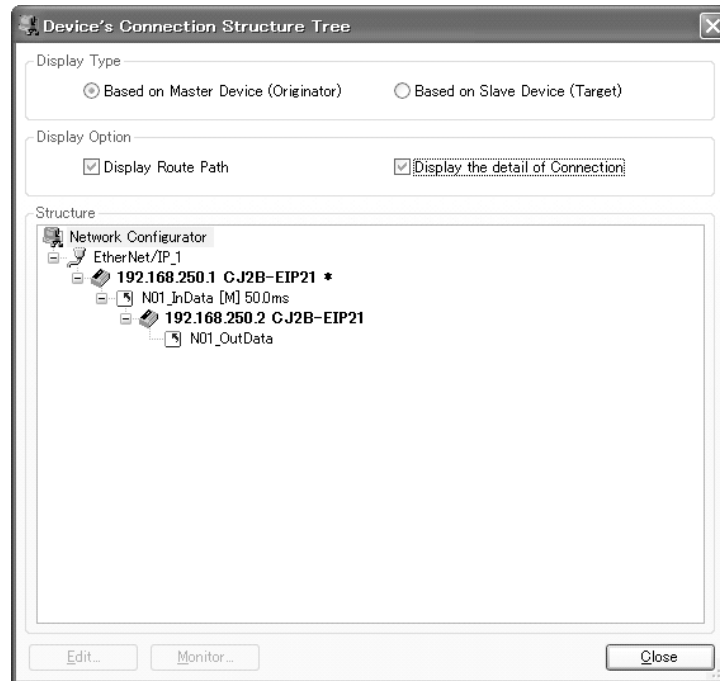

- The *Display the detail of Connection* Check Box can be used to switch between device-level and connection-level displays of tag data link communications.
- An asterisk will be displayed after the device name of the originator set for the connection.
- The Edit Device Parameters Dialog Box can be displayed by selecting a connection and clicking the **Edit** Button. The connections can be edited in this dialog box.

## 6-2-6 Setting Tags Using Data Link Tool

Using the EtherNet/IP Datalink Tool enables easily setting data links similar to those for the Controller Link by using only I/O memory addresses. This method has the following restrictions.

- Settings can be made only for tag data links between OMRON EtherNet/IP Units and built-in EtherNet/IP ports.
- Tags must be set using I/O memory addresses.
- A maximum of two tags (area 1 and area 2) can be set in one tag set.

Select **Network - EtherNet/IP Datalink Tool** from the menus in the Network Configurator after you have registered all the devices to start the EtherNet/IP Datalink Tool.

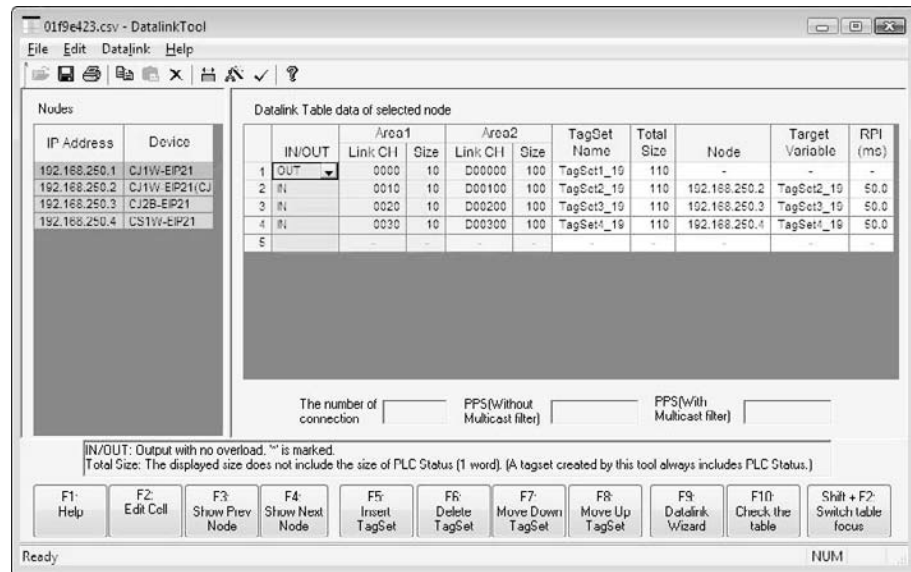

### Node List

The following items will be displayed in the Node Area on the left side of the window.

- IP Address: The IP address of the node.
- Device: The name (model number) of the device at the node.

### Note

The node list will display the node registered in the Network Configurator. Nodes cannot be added or deleted from this window.

### Data Link Table Information

The data link table of the node selected on the left will be displayed on the right. Each row specifies word that are allocated for data links for that node. Each row specifies the node settings for the words (area) where a data link has been created. You can set only area 1 or both area 1 and area 2.

- IN/OUT: Specifies whether the link inputs data to the node or outputs data from the node. *OUT* can be selected only once. Once *OUT* has been selected for one row, *IN* will automatically be selected for other rows. A asterisk will be displayed if the Over Load function is disabled. (See note.)

**Note** The Over Load function is used to clear output data when all outputs are turned OFF from the CPU Unit of the PLC. This setting is not necessary for inputs.

(a) Over Load function enabled: Output data will be cleared to all zeros when all outputs from the PLC are turned OFF from the CPU Unit.

(b) Over Load function disabled: Output data will be maintained even when all outputs from the PLC are turned OFF from the CPU Unit.

- Area 1, Link CH: The I/O memory address of the first word in link area 1
- Area 1, Size: The number of words in link area 1. (See note.)
- Area 2, Link CH: The I/O memory address of the first word in link area 2
- Area 2, Size: The number of words in link area 2. (See note.)

**Note** With the Network Configurator, the PLC status will be shown at the beginning of each area. The PLC status includes the CPU Unit operating status (operating information and error information).

- **Tag Set Name:** If the Wizard is used, the names will be automatically assigned using consecutive IP addresses in the following form for both input and output tags: TagSet1\_192.168.250.1. There is no reason to be concerned with these names. If the Wizard is not used, then names will not be automatically assigned and they must be entered directly into the data link table.
- **Total Size:** The total number of words in areas 1 and 2. If PLC status is included, the displayed value will be incremented by 1 word (Network Configurator 1.21 or higher). This value is automatically displayed after the sizes of areas 1 and 2 are entered.
- **Node:** For an input tag, this is the IP address of the node that provides the output. For an output tag, “-” will be entered automatically.
- **Target Variable:** The target tag set name. For an input tag, this is the name of the target set that provides the output. For an output tag, “-” will be entered automatically.
- **RPI (ms):** The requested packet interval for an input tag. For an output tag, “-” will be entered automatically.

**Setting Procedure**

The setting procedure is described here along with setting examples.

■ **Setting Example A**

- Area 1 memory area = Work Area (W)
- Area 1 start address = 0
- Area 1 size = 50 words
- Area 2 memory area = DM Area (D)
- Area 2 start address = 50
- Area 2 size = 100 words

■ **Allocations**

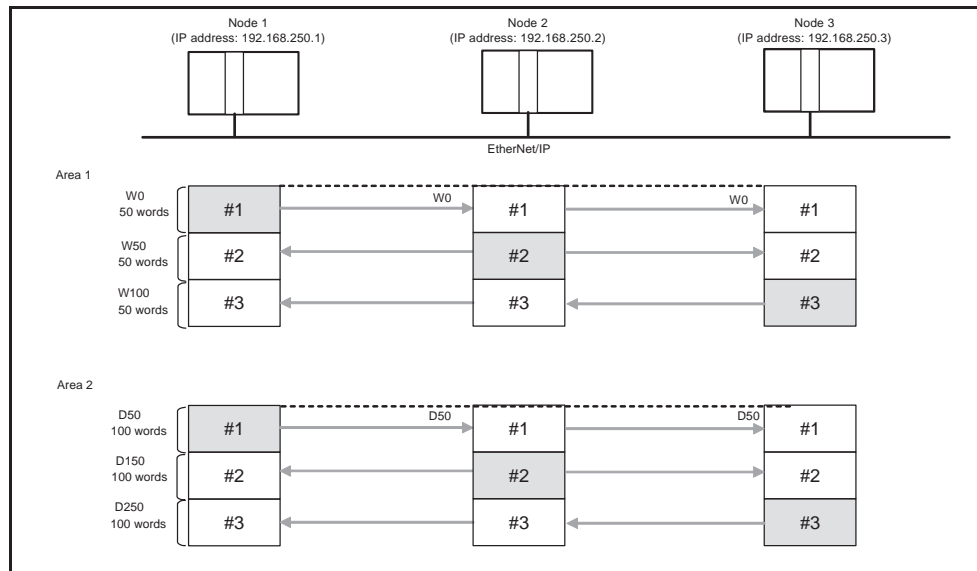

- 1,2,3... 1. Select **Wizard** from the Data Link Menu. The Datalink Wizard Dialog Box will be displayed.

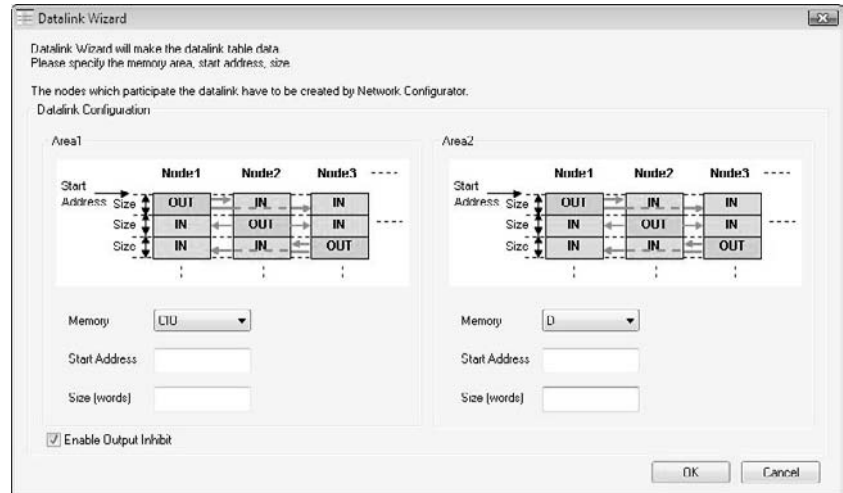

2. Select the memory area (here, W) in the *Memory* Field and enter the starting address (here, 0) and number of words (here, 50) in the *Start Address* and *Size* Fields for Area 1.
3. Select the memory area (here, D) in the *Memory* Field and enter the starting address (here, 50) and number of words (here, 100) in the *Start Address* and *Size* Fields for Area 2.
4. Select the Enable Over Load Check Box if the Over Load function is necessary.

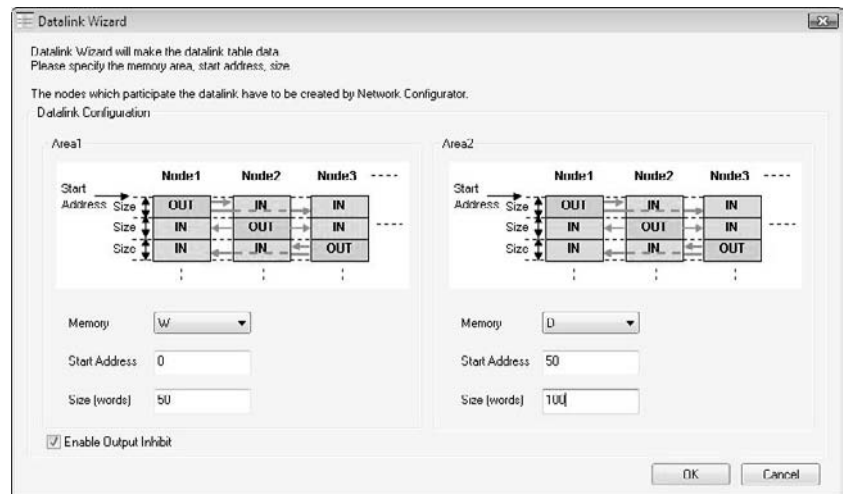

5. Click the **OK** Button. The following dialog box will be displayed. Click the **Yes** Button to continue creating the data link table, or click the **No** Button to cancel the operation.

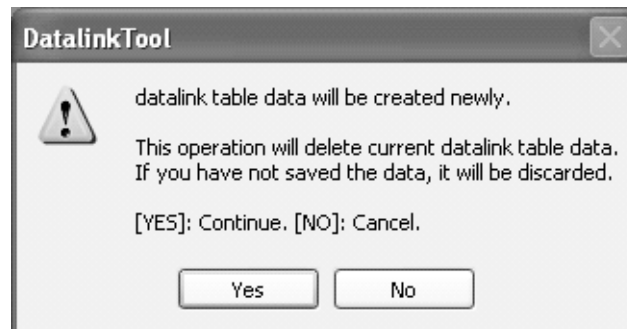

If the creating the data link table is continued, the data link table will be created with the same size of data link for all registered nodes. Examples are shown below.

**Automatic Allocation Results for Node 1 (IP Address: 192.168.250.1)**

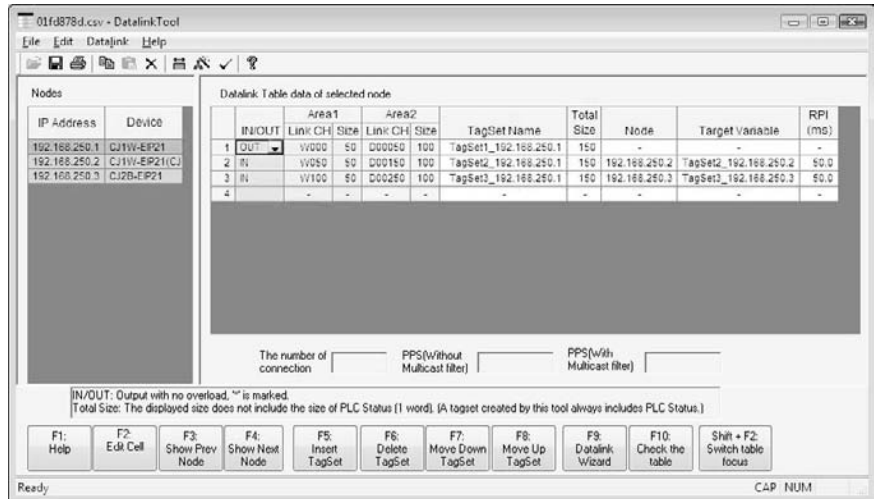

**Automatic Allocation Results for Node 2 (IP Address: 192.168.250.2)**

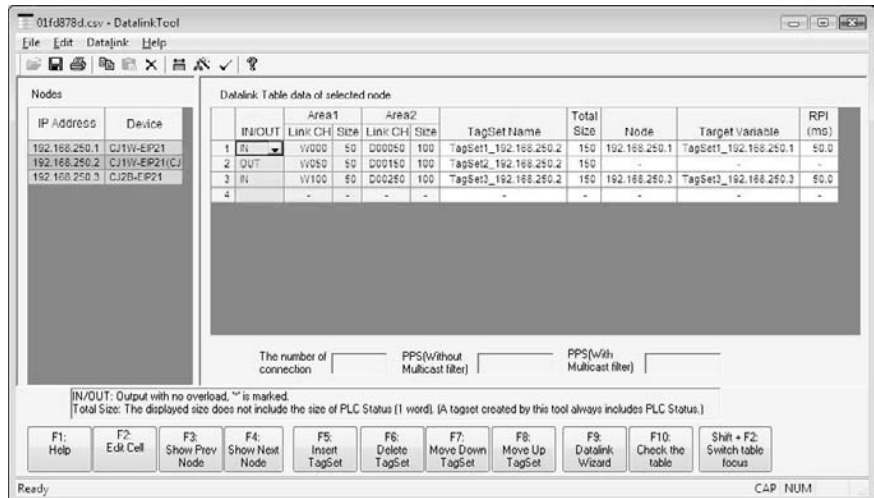



Automatic Allocation Results for Node 3 (IP Address: 192.168.250.3)

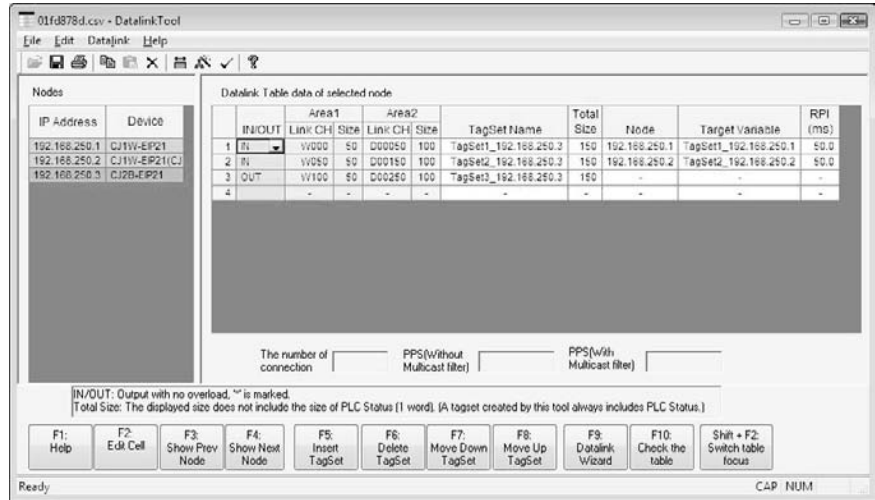

6. After entering all of the settings in the data link table, select **Save** from the File Menu. A consistency check will be performed on the table and the results will be displayed.
  - a. Table Inconsistencies

The following Check Result Dialog Box will be displayed. Correct the data link table according to the displayed information.

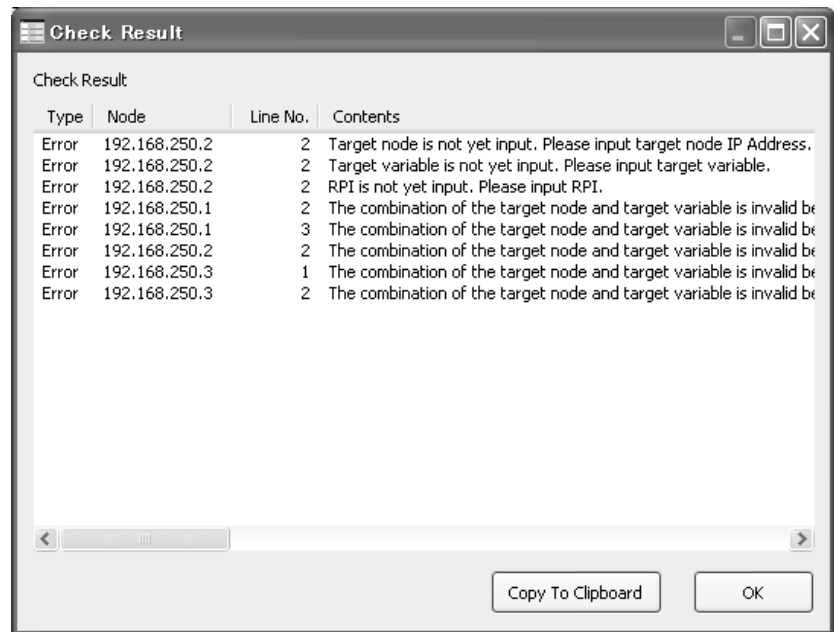

To save the check results, click the **Copy To Clipboard** Button and paste the results to other file, such as the text pad.

Click the **OK** Button. The following message will be displayed. Click the **OK** Button again to return to the EtherNet/IP Datalink Tool Window.

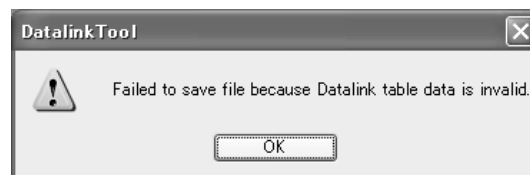

b. No Table Inconsistencies

The following message will be displayed. Click the **OK** Button.



7. Select **Exit** from the File Menu. The EtherNet/IP Datalink Tool will be exited and you'll return to the Network Configurator.
8. Returning to the Network Configurator  
Click the icon for each device and check the settings made with the EtherNet/IP Datalink Tool in the Edit Device Parameters Dialog Box.

### 6-2-7 Creating Connections Using the Wizard

You can use the Network Configurator's Wizard to easily create connections between OMRON PLCs following the instructions provided by the Wizard. Network Configurator version 3.10 or higher is required to use the Wizard.

**Note** The Wizard can be used only with the following OMRON EtherNet/IP devices.

Device name	Remarks
CJ1W-EIP21	CJ1W-EIP21 mounted to CJ1 CPU Unit
CJ1W-EIP21(CJ2)	CJ1W-EIP21 mounted to CJ2 CPU Unit
CJ2B-EIP21	Built-in EtherNet/IP port in CJ2H CPU Unit
CJ2M-EIP21	Built-in EtherNet/IP port in CJ2M CPU Unit
CS1W-EIP21	CJ1W-EIP21 mounted to CS1 CPU Unit

Use the following procedure to create connections (i.e., data links) with the Wizard.

- 1,2,3...**
1. Set tags and tag sets for all devices before starting the Wizard. Refer to 6-2-4 *Creating Tags and Tag Sets* for the setting procedure.
  2. For tag data links between OMRON PLCs, a connection is created in the PLC (i.e., the originator device) that receives data as input data. First, select the registered device for which you want to create a connection in the Network Configuration Window of the Network Configurator, and then select **Device - Parameters - Wizard** from the menus.

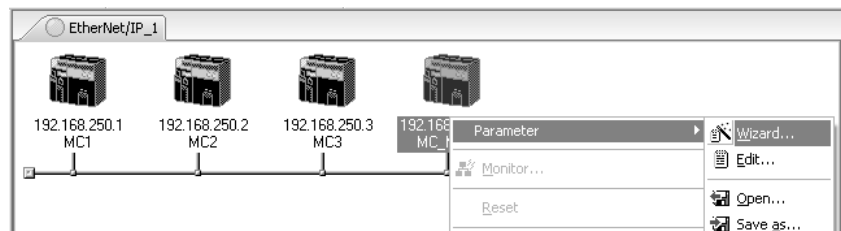

The following dialog box will be displayed before the Wizard starts.

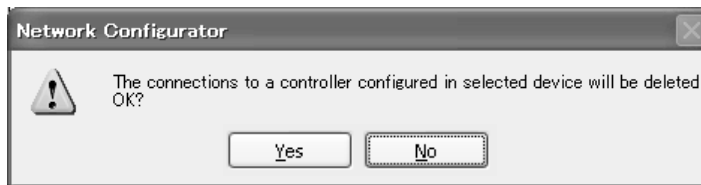

Click the **Yes** Button to delete the connections that have been set with OMRON PLCs before starting the Wizard.

3. Create the connection following the instructions that are given by the Wizard after the Wizard starts. (See the following figure.)

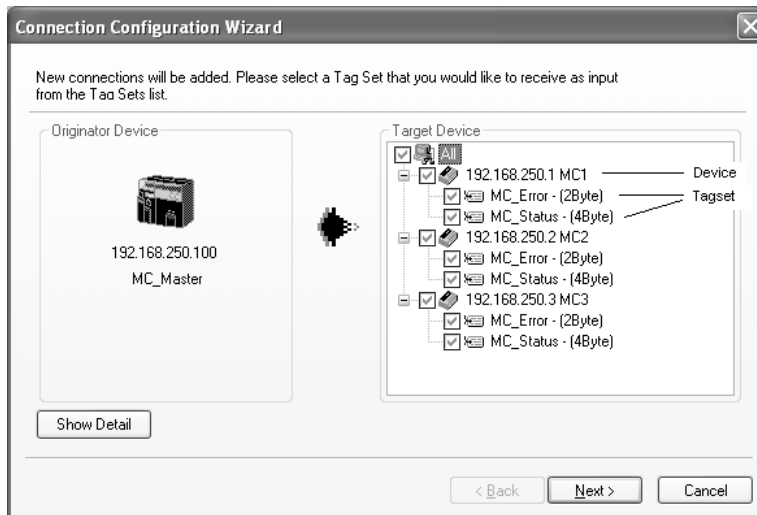

4. A list of tag sets is displayed on the right side of the Wizard Dialog Box with target devices that support receiving input data. Select the tag sets that you want to receive at the originator device. The following tables describes the meanings of the icons and check marks displayed in the tag set list.

Icon	Display position	Status
<input checked="" type="checkbox"/>	All	All output tag sets for all devices are selected.
	Device	All output tag sets for the applicable device are selected.
	Tag set	The applicable output tag sets are selected. These are the tag sets that will be set in the connection.
<input checked="" type="checkbox"/>	All	All or some output tag sets for some devices are selected.
	Device	Some output tag sets for applicable devices are selected.
<input type="checkbox"/>	All	All output tag sets for all devices are not selected.
	Device	All output tag sets for applicable devices are not selected.
	Tag set	The applicable output tag sets are not selected. The connections for this tag set will be deleted.
<input type="checkbox"/>	Device	No applicable tag sets.

**Note** Tag sets that are used in connections that are already set are not displayed.

The following display will appear when you click the **Show Detail** Button.

The specified values for detailed parameters will be displayed. Change the values as required. The connection name cannot be set. They are automatically created using the following rule.

default\_N (where N is a 3-digit number (001, 002, etc.) starting from 1)

- Click the **Next** Button to switch to the table in the following Wizard Dialog Box. Follow the instructions to select and input from the list box the input tag set of the originator device that receives the output tag set of the target device.

Input Tag Set	Target Device	Output Tag Set	Connection Type	RPI	Timeout ...
MC1_Error - [2Byte]	192.168.250.1 MC1	MC_Error - [2Byte]	Multi-cast connection	50.0 ms	RPI x 4
MC1_Status - [4Byte]	192.168.250.1 MC1	MC_Status - [4Byte]	Multi-cast connection	50.0 ms	RPI x 4
MC2_Error - [2Byte]	192.168.250.2 MC2	MC_Error - [2Byte]	Multi-cast connection	50.0 ms	RPI x 4
	192.168.250.2 MC2	MC_Status - [4Byte]	Multi-cast connection	50.0 ms	RPI x 4
MC2_Status - [4Byte]	192.168.250.3 MC3	MC_Error - [2Byte]	Multi-cast connection	50.0 ms	RPI x 4
MC3_Status - [4Byte]	192.168.250.3 MC3	MC_Status - [4Byte]	Multi-cast connection	50.0 ms	RPI x 4

- The blank area in the Input Tag Set Column is the connection that you are creating.
  - The rows in which there are input tag sets are connections that are already set.
  - To prevent duplicate settings, input tag sets that have been used are not displayed in the list box for input tag sets.
  - If there is no applicable input tag set, you can edit a tag set or create a new one by using the **Edit Tag Sets** Button and **Edit Tag** Button.
- Once the input tag set settings have been completed, click the **Finish** Button. You can check the set connection by selecting **Network - View Devices Connection Structure Tree** from the menus.
    - The Wizard can be ended even if the input tag set includes a blank row. In that case, a connection is not created for the blank row.
    - You can delete a connection by deleting the input tag sets that were previously set.

### 6-2-8 Creating Connections by Device Dragging and Dropping

You can create a connection to the originator by dragging a target device and dropping it at the originator device. Network Configurator version 3.10 or higher is required to drag and drop devices to make connections.

Example: Drag the target device at 192.168.250.1 and drop it at the originator device at 192.168.250.100.

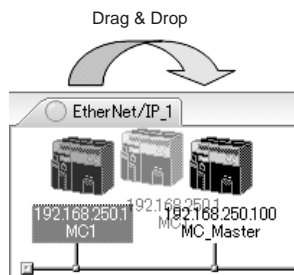

**Note** The EtherNet/IP originator device (i.e., a device in which connections can be set) must be one of the following OMRON EtherNet/IP devices.

Device name	Remarks
CJ1W-EIP21	CJ1W-EIP21 mounted to CJ1 CPU Unit
CJ1W-EIP21(CJ2)	CJ1W-EIP21 mounted to CJ2 CPU Unit
CJ2B-EIP21	Built-in EtherNet/IP port in CJ2H CPU Unit
CJ2M-EIP21	Built-in EtherNet/IP port in CJ2M CPU Unit
CS1W-EIP21	CJ1W-EIP21 mounted to CS1 CPU Unit

Use the following procedure to create connections (i.e., data links) by dragging and dropping devices.

- 1,2,3...**
1. Set the tags and tag sets for the target device that will be dragged.
    - a. Refer to 6-2-4 *Creating Tags and Tag Sets* for information on creating the settings if the target is one of the OMRON EtherNet/IP devices given above.
    - b. If the target is another EtherNet/IP device, refer to the manual of that device and perform settings as required.
  2. A dialog box as in the following figure for connection allocation will be displayed when you drag the target device and drop it at the OMRON EtherNet/IP device.
    - a. Using One of the Above OMRON EtherNet/IP Devices As Target

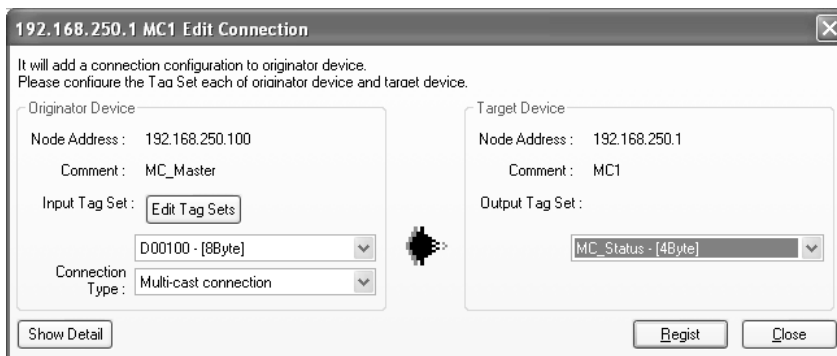

Select the output tag set from *Target Device Area* on the right side of the Edit Connection Dialog Box, and then select the input tag set to receive the output tag set in the *Originator Device Area* on the left.

- If there is no applicable input tag set at the originator, you can create a new one by using the **Edit Tag Sets** Button and **Edit Tag** Button.
- b. Using Other EtherNet/IP Devices as Target

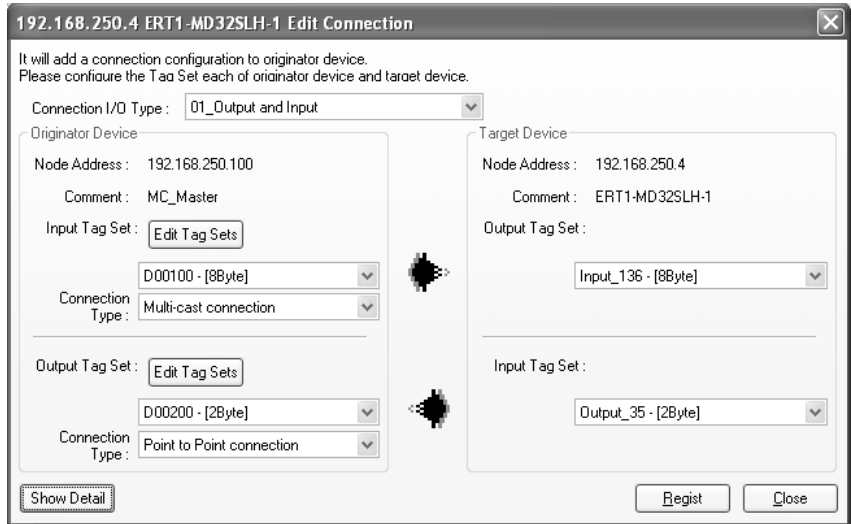

The connection I/O type list box in the upper part of the Connection Settings Dialog Box displays the connection I/O types that can be selected. Select the connection I/O type according to your application.

- The connection I/O types that can be selected depend on the target device.
- Items that can be selected will depend on the connection I/O type that is selected.
- Select the output, input, or both output and input tag sets at the target and specify the corresponding input, output, or both input and output tag sets at the originator.
- If there is no applicable tag set at the originator, you can create a new one by using the **Edit Tag Sets** Button and **Edit Tag** Button.

The following display will appear when you click the **Show Detail** Button.

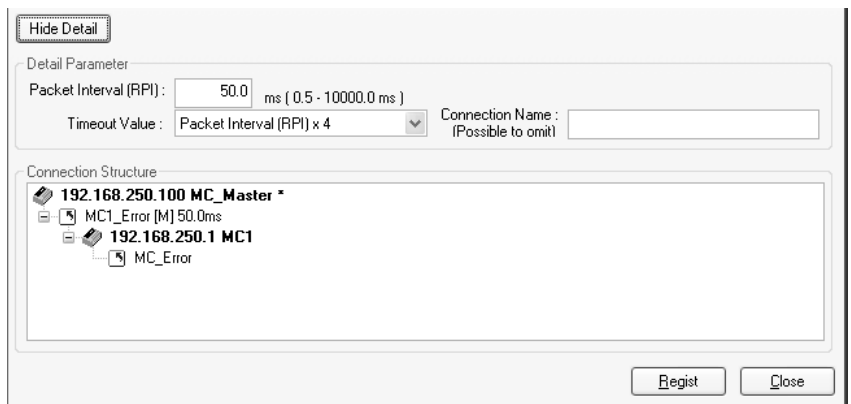

The specified values for detailed parameters will be displayed. Change the values as required. Connection names are automatically created using the following rule.

default\_N (where N is a 3-digit number (001, 002, etc.) starting from 1)

- Note** The following dialog box will be displayed if a target device that does not have I/O data is dropped.



Before dropping again, refer to the manual of the applicable device and create the I/O data (i.e., output tag sets) required to create a connection.

- After you have set all of the connection, click the **Register** Button to create the connection. When creating the connection has been completed, the input tag set and output tag set will be blank. Next, you can continue to create connections by selecting the connection I/O type and setting a tag set.

## 6-2-9 Connecting the Network Configurator to the Network

This section explains how to connect the Network Configurator to the network.

### Connecting through Ethernet

- Note** The Windows firewall settings must be changed when making this connection for the first time in Windows XP, Vista, or Windows 7. For details on changing the firewall settings, refer to *Appendix G Precautions for Using Windows XP, Vista, or Windows 7*.

Connect to the EtherNet/IP Unit's Ethernet port via the Ethernet network.

- 1,2,3... Select **Option - Select Interface - Ethernet I/F**.
- Select **Network - Connect**.

If there are multiple Ethernet interfaces on the computer, the Select Connect Network Port Dialog Box will be displayed. Select the interface that is to be connected, and press the **OK** Button. The following dialog box will be displayed.



- Click the **OK** Button. Select the network to be connected.

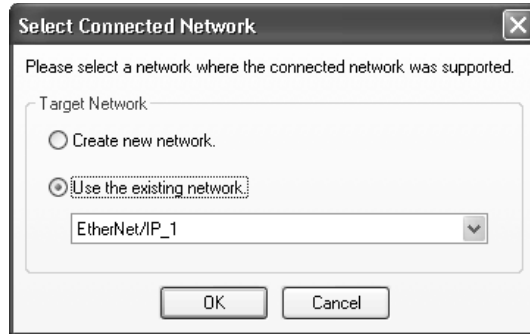

The Network Configurator will connect to the EtherNet/IP network. If the Network Configurator is connected online properly, *On-line* will be displayed in the status bar at the bottom of the window. The network connection icon will be displayed in blue in the Network Tab Page in which the Network Configurator is connected.

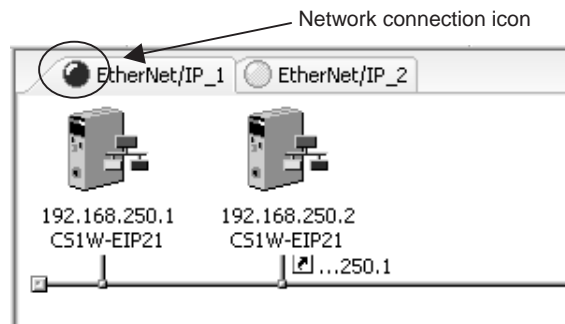

The connecting network can be switched by selecting **Network - Change Connect Network.**

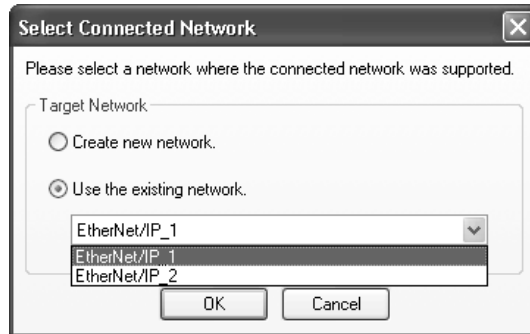

**Connecting through the CPU Unit’s Peripheral or RS-232C Port**

Connect to the EtherNet/IP Unit’s Ethernet port via the CPU Unit’s peripheral port or RS-232C port.

- 1,2,3... 1. Select **Option - Select Interface - CS/CJ1 Serial Port** → **EIP Unit I/F**
- 2. Select **Network - Connect**. The following dialog box will be displayed.



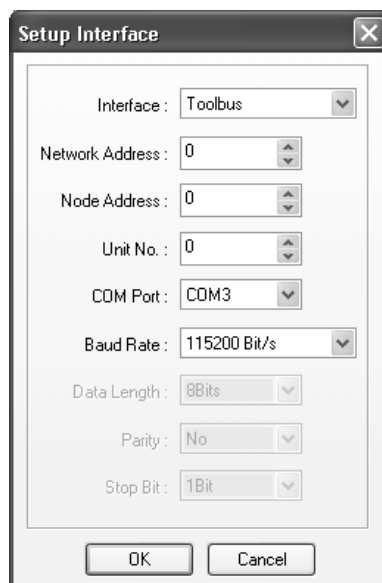

- Input the EtherNet/IP Unit's unit number in the *Unit No.* Field, select the connecting COM port number, and click the **OK** Button. Usually, the *Baud Rate* is left at this setting. The following dialog box will be displayed.



- After clicking **TCP:2**, click the **OK** Button. The Network Configurator will be connected to the EtherNet/IP network. If the Network Configurator is connected online properly, *On-line* will be displayed in the status bar at the bottom of the window.

### **Connecting through the CPU Unit's USB or RS-232C Port (CJ2 CPU Units Only)**

Connect to the EtherNet/IP Unit's Ethernet port via the CPU Unit's USB port or RS-232C port.

- 1,2,3...** 1. Select **Option - Select Interface - CJ2 USB/Serial Port** to set the communications interface.

2. Select **Network - Connect**. The Setup Interface Dialog Box will be displayed.

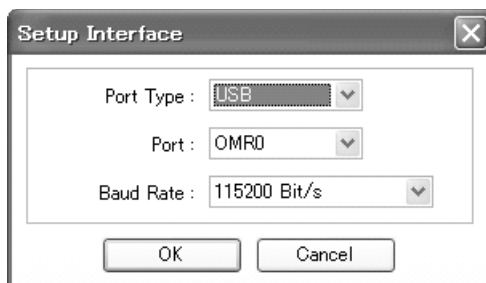

3. Set the port type to either USB or serial.
4. Set the port to use and then click the **OK** Button. (Leave the baud rate at the default setting.)  
The following dialog box will be displayed.

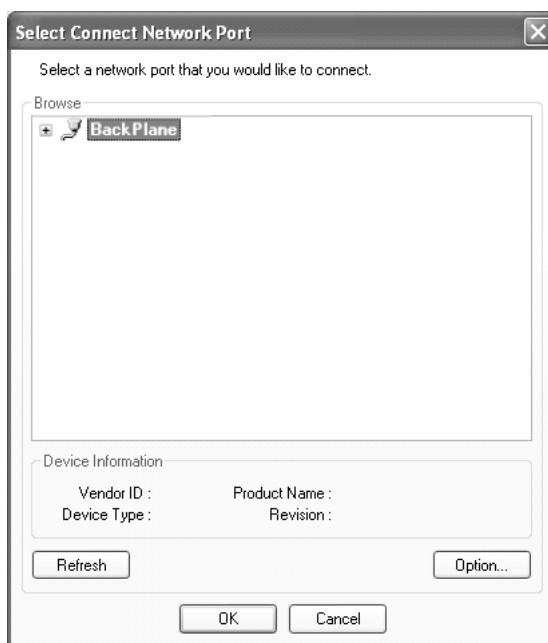

5. Select the *Backplane* Icon and click the **Refresh** Button. The CPU Unit, CPU Bus Units, and Special I/O Units connected in the PLC will be displayed as shown below.

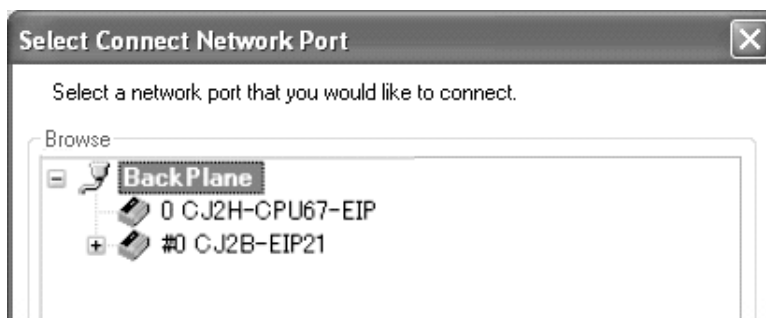

6. Click the + icon to the left of the EtherNet/IP Unit or built-in EtherNet/IP port (CJ1W-EIP21(CJ2) or CJ2B-EIP21). The TCP ports on the EtherNet/IP Unit will be displayed as shown below.

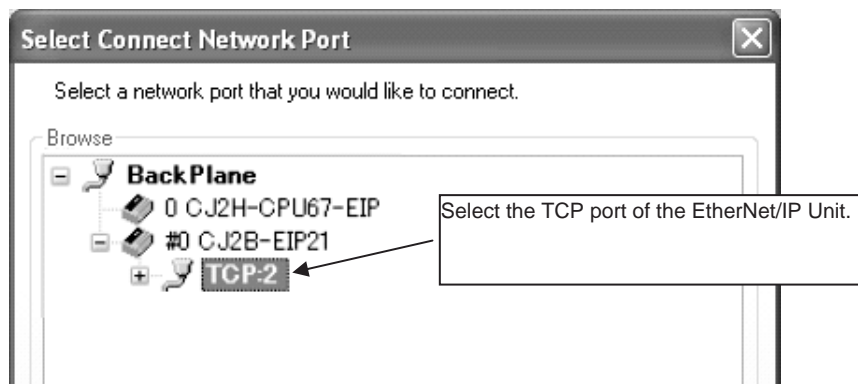

7. Select the port for the EtherNet/IP Unit and then click the **OK** Button. The Network Configurator will be connected to the EtherNet/IP network. If the Network Configurator goes online normally, "On-line" will be displayed in the status bar at the bottom of the window.

### Connecting to an EtherNet/IP Network via an Ethernet Unit

- Note**
- (1) Windows firewall settings must be changed when this connection is made for the first time using Windows XP (SP2 or higher), Vista, or Windows 7. Refer to *Appendix G Precautions for Using Windows XP, Vista, or Windows 7: Using EtherNet/IP with Windows XP, Vista, or Windows 7* for information on how to make the changes.
  - (2) Use the CX-Integrator to correctly set the FINS routing tables for the CS/CJ-series CPU Unit that will be the relay node.

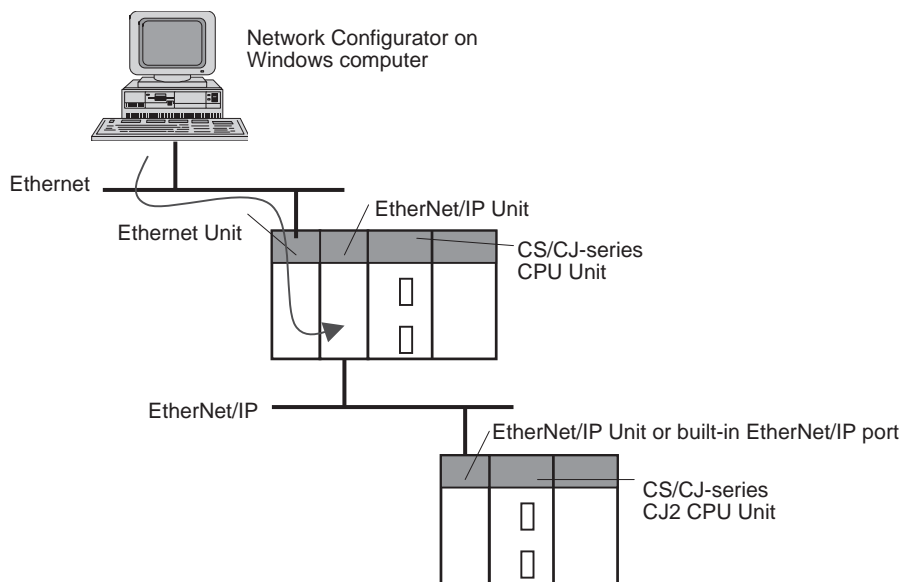

- 1,2,3... 1. Select **Option - Select Interface - Ethernet** → **CS/CJ1 ETN-EIP Unit I/F**

2. Select **Network - Connect**.

The following Setup Interface Dialog Box will be displayed.

3. Click the **Setup** Button in the Setup Interface Dialog Box. The *Registration of the connection* Dialog Box will be displayed. Enter the network information for the connection destination, and then click the **Add** Button to register the settings.

Registratio...	Node	Unit	Port	I...
EIP	1	1	2, 3, 2	9600, 1

The registration information details are as follows:

- a. Registration name  
Enter any name.
- b. Host (PC) information  
Enter information for the computer that has the Network Configurator installed.
  - Network address  
Same number as the network address of the Ethernet Unit of the PLC that will be the relay node.
  - Node address  
Last value in the computer's IP address (e.g., 1 for 192.168.250.1)
- c. Remote Information - EtherNet/IP Unit  
Enter the information for the EtherNet/IP Unit of the PLC that will be the relay node.
  - Network address  
Network address set in the routing tables

- Node address  
Last value in the IP address of the Unit above (e.g., 3 for 192.168.251.3)
  - Unit number of CPU Bus Unit  
Unit number of the Unit above
- d. Remote Information - Ethernet Unit  
Enter the information for the Ethernet Unit of the PLC that will be the relay node.
4. Once the settings have been registered, the Setup Interface Dialog Box will be displayed again. Check the registered information that has been entered, and then click the **OK** Button.

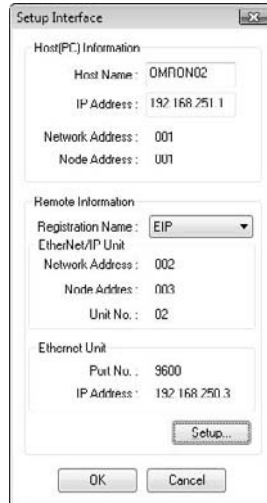

5. The following dialog box will be displayed. Select *TCP:2*, which represents the EtherNet/IP port, and then click the **OK** Button.



The Network Configurator will connect to the EtherNet/IP network, and “On-line” will be displayed in the status bar at the bottom of the window when connection has been properly made online.

**Note** A list of nodes on the EtherNet/IP network you are attempting to connect to will be displayed when the **Refresh** Button or the icon (⊕) at the left of *TCP:2*

is clicked in the dialog box above. (Refer to the following figure.)

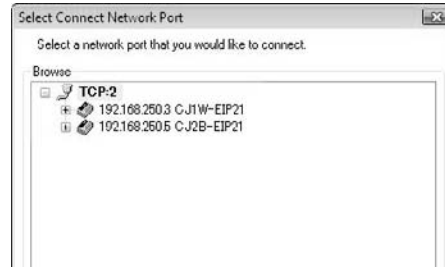

## 6-2-10 Downloading Tag Data Link Parameters

To make tag data links, you must download tag data link parameters, such as tag set settings and connection settings, to all devices in the EtherNet/IP network. When the download operation is executed, the tag data link parameters will be transferred to the EtherNet/IP Units that require the settings.

The following procedure shows how to download the tag data link parameters. Refer to 6-2-9 *Connecting the Network Configurator to the Network* for information on how to connect the Network Configurator to the network.

### Note

- If the target node IP address is not set correctly, invalid device parameters may be set in the wrong PLC. Check the connected PLC before downloading parameters.
- If incorrect tag data link parameters are set, it may cause equipment to operate unpredictably. Even when the correct tag data link parameters are set, make sure that there will be no effect on equipment before transferring the data.
- When network symbols are used in tag settings, a connection error will result if the symbols are not also set in the CPU Unit. Before downloading the tag data link parameters, check to confirm that the network symbols have been set in the CPU Unit. On the Connection and Tag Status Tab Pages described in 14-1-1 *The Network Configurator's Device Monitor Function*, check whether the network symbol, tag, and connection settings are correct.
- When a communications error occurs, the output status depends on the specifications of the Unit being used. When a communications error occurs for a Unit that is used along with output devices, check the operating specifications and implement safety countermeasures.
- The EtherNet/IP Unit is automatically restarted after the parameters have been downloaded. This restart is required to enable the tag set and connection information that have been set. Before downloading the parameters, check to confirm that restarting will not cause any problems with the equipment.
- Do not disconnect the Ethernet cable or reset or turn OFF the power to the EtherNet/IP Unit while the parameters are being downloaded
- For EtherNet/IP Units or built-in EtherNet/IP ports with revision 2 or later, the CPU Unit can download tag data link parameters in either RUN mode or MONITOR mode. (They can also be downloaded in PROGRAM mode.)
- For EtherNet/IP Units with revision 1, tag data link parameters can be downloaded only when the CPU Unit is in PROGRAM mode.
- Even for Units with revision 2 or later, all CPU Units must be in PROGRAM mode to download the parameters if any Units with revision 1 are included in the network.

1,2,3...

1. Connect the Network Configurator online.
2. There are two ways to download the parameters.
  - Downloading to All Devices in the Network  
Select **Network - Download**. The following dialog box will be displayed.



- Downloading Individually to Particular Devices  
Select the icon of the EtherNet/IP Unit to which you want to download. To select multiple nodes, press and hold the Shift Key while selecting additional icons. (In the following example, 2 nodes are selected: 192.168.250.1 and 192.168.250.2.)  
After selecting the icons, click the right mouse button over the icon to display the pop-up menu, and select **Parameter - Download**.

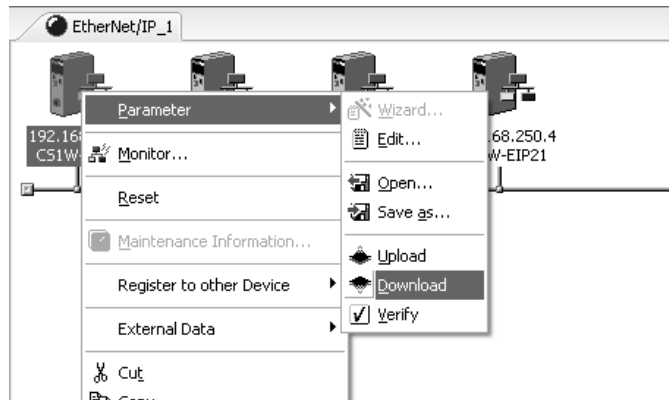

The following dialog box will be displayed.



3. Click the **Yes** Button to download the tag data link parameters to the EtherNet/IP Unit.  
The following dialog box will be displayed if any of the CPU Units is not in PROGRAM mode.
  - Display When All EtherNet/IP Units and Built-in EtherNet/IP Ports are Revision 2 or Higher

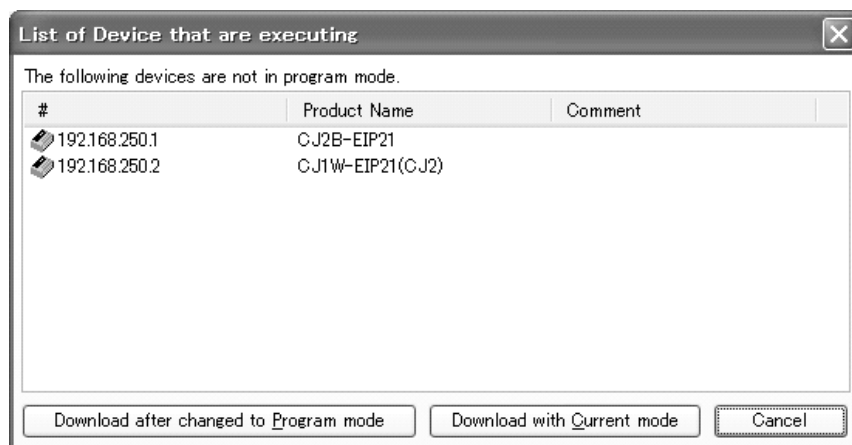

If the **Download after changed to Program mode** Button is clicked, all CPU Units will be changed to PROGRAM mode and the parameters will be downloaded. Confirm safety for all controlled equipment if the CPU Units are changed to PROGRAM mode. The operating mode can be returned to the previous setting after the parameters have been downloaded. The **Download with Current mode** Button can be clicked to download load the parameters even when one or more CPU Units is in RUN or MONITOR mode.

- Display When Even One EtherNet/IP Unit Is Revision 1

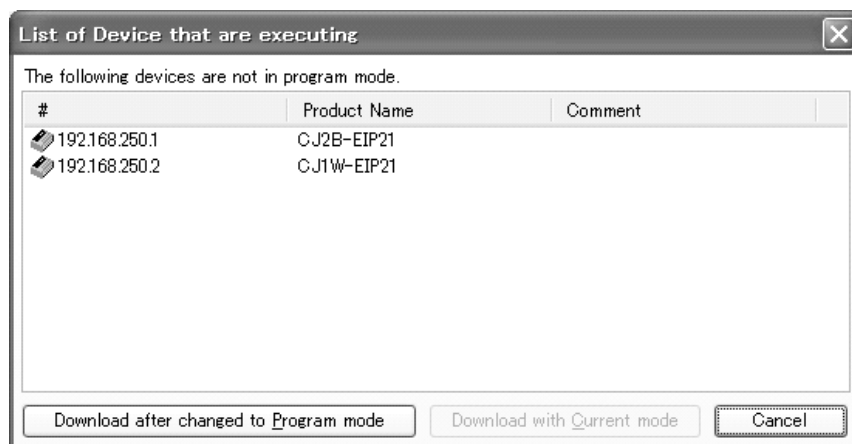

When the **Download after changed to Program mode** Button is clicked, all CPU Units will be changed to PROGRAM mode and the parameters will be downloaded. Confirm safety for all controlled equipment if the CPU Units are changed to PROGRAM mode. The operating mode can be returned to the previous setting after the parameters have been downloaded. During the download, the following progress monitor will be displayed to show the progress of the download.

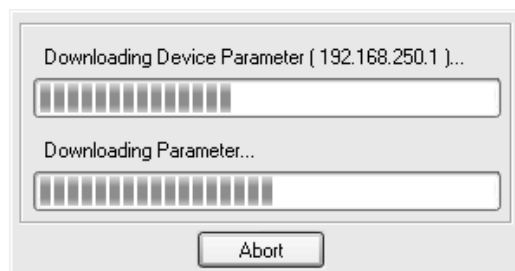



If the operating mode of one or more CPU Units was changed to download the parameters, the CPU Units can be returned to the previous operating mode. If the **No** Button is clicked, the CPU Units will remain in PROGRAM mode.

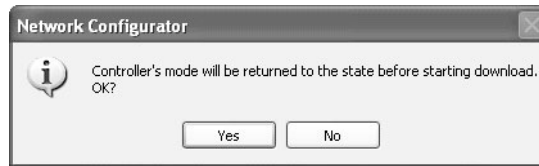

4. The following dialog box will be displayed, indicating that the download was completed.



## 6-2-11 Uploading Tag Data Link Parameters

Tag data link parameters (such as the tag set settings and connection settings) can be uploaded from EtherNet/IP Units in the EtherNet/IP network. The following procedure shows how to upload the parameters. For details on connecting to the network from the Network Configurator, refer to 6-2-9 *Connecting the Network Configurator to the Network*.

1,2,3...

1. Connect the Network Configurator to the network.
2. There are two ways to upload the parameters.
  - Uploading from All Devices in the Network  
Select **Network - Upload**. The following dialog box will be displayed.



- Clicking the **Yes** Button:  
Parameters will be uploaded only from the devices registered in the Network Configuration Window. Parameters will not be uploaded from devices that are not registered in the Network Configuration Window.
- Clicking the **No** Button:
  - If parameters are being uploaded from all devices in the network, the parameters will be newly uploaded from all devices. The current network configuration information will be lost.
  - If parameters are being uploaded from specified devices only, the upload operation will be cancelled and the upload will not be performed.
- Clicking the **Cancel** Button:  
The upload operation will be cancelled and the upload will not be performed.
- Uploading Individually from Particular Devices

Select the icon of the EtherNet/IP Unit from which you want to upload. To select multiple nodes, press and hold the Shift Key while selecting additional icons. (In the following example, 2 nodes are selected: 192.168.250.1 and 192.168.250.2.)

After selecting the icons, click the right mouse button over the icon to display the pop-up menu, and select **Parameter - Upload**.

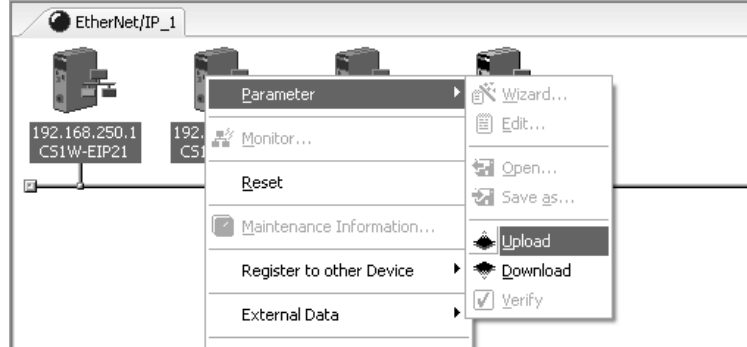

The following confirmation dialog box will be displayed.

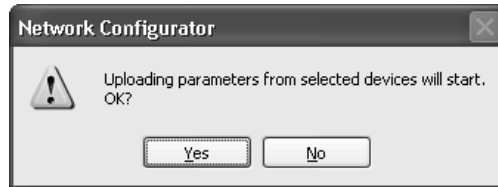

Click the **Yes** Button or **No** Button.

During the upload, the following progress monitor will be displayed to show the progress of the upload.

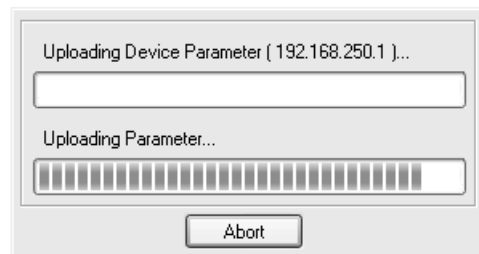

3. The following dialog box will be displayed, indicating that the upload was completed.



### 6-2-12 Verifying the Tag Data Links

Tag data link parameters (such as the tag set settings and connection settings) can be compared with the EtherNet/IP Units in the EtherNet/IP network. The following procedure shows how to compare the parameters. For details on connecting to the network from the Network Configurator, refer to 6-2-9 *Connecting the Network Configurator to the Network*.





Click the **OK** Button or the Close Button.

### Verifying the Device Parameters

Use the following procedure to compare the device parameters for the devices selected in the Network Configuration Window with those of the devices connected on the EtherNet/IP network. The IP addresses, device types, and device parameters are compared.

- 1,2,3... 1. Connect the Network Configurator to the network.
2. Click the icon of the EtherNet/IP Unit that is to be verified. To select multiple nodes, hold down the Shift Key while clicking the icons. (In the following example, the 192.168.250.1 and 192.168.250.2 nodes are selected.)  
With the icons selected, right-click and select **Parameter - Verify** from the pop-up menu.

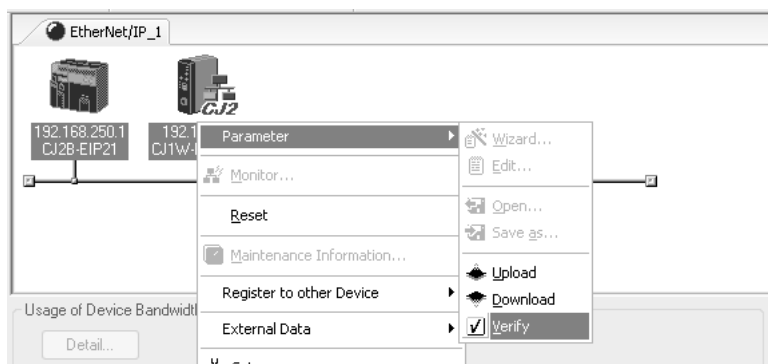

3. The following dialog box will be displayed.



Click the **Yes** Button or the **No** Button.

4. One of the following dialog boxes will be displayed.
  - Differences Not Found in the Comparison

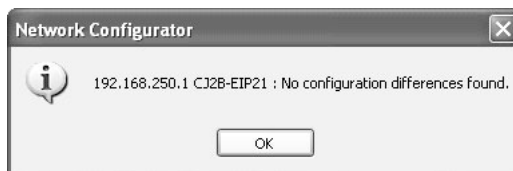

- Differences Found in the Comparison

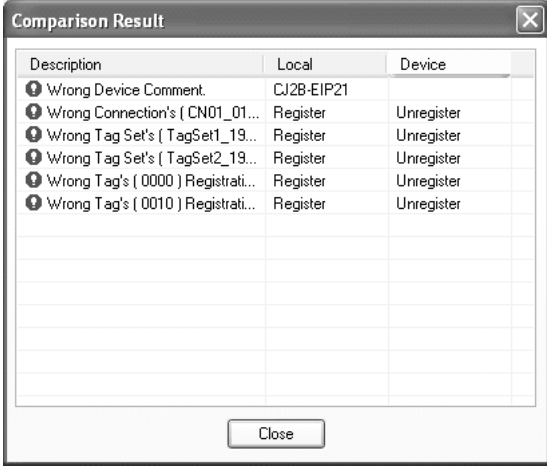

Description	Local	Device
Wrong Device Comment.	CJ2B-EIP21	
Wrong Connection's ( CN01_01...	Register	Unregister
Wrong Tag Set's ( TagSet1_19...	Register	Unregister
Wrong Tag Set's ( TagSet2_19...	Register	Unregister
Wrong Tag's ( 0000 ) Registrati...	Register	Unregister
Wrong Tag's ( 0010 ) Registrati...	Register	Unregister

- Differences Found in the Device Type



Click the OK Button or the Close Button.

5. If multiple nodes have been selected, the following message will be displayed. Click the **Yes** Button.



The comparison results will be displayed in order of the selected nodes.

## 6-2-13 Starting and Stopping Tag Data Links

### Automatically Starting Tag Data Links

Tag data links will start operating automatically immediately after the tag data link parameters are downloaded from the Network Configurator. (They will also start automatically when the power to the PLC is turned ON or the CPU Unit is restarted.)

### Starting and Stopping All Tag Data Links on the Network

#### Using the Network Configurator

All tag data links on the network can be started and stopped by selecting **I/O Connection - Start/Stop** from the Network Menu.

### Starting and Stopping Tag Data Links for Individual Devices

#### Using the Network Configurator

You can start and stop tag data links for individual devices using the following buttons in the Monitor Device Dialog Box. This applies only to tag data links for which the device is the originator. Access the Monitor Device Dialog Box by selecting **Monitor** from the Device Menu.

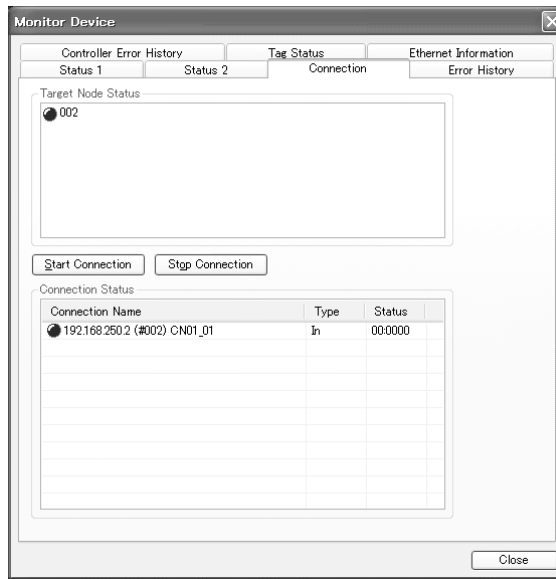

**Start Connection Button:**

Starts all connections for which the device is the originator.

**Stop Connection Button:**

Stops all connections for which the device is the originator.

**Note** Connections will be cut off if any of the following errors occurs in the CPU Unit that is the originator while tag data links are active.

- Fatal CPU Unit error
- I/O refresh error
- CPU Unit WDT error
- I/O bus error

### 6-2-14 Clearing the Device Parameters

The device parameters saved in the EtherNet/IP Units in the EtherNet/IP network can be cleared (returned to their default settings). The following procedure shows how to clear the device parameters. For details on connecting to the network from the Network Configurator, refer to 6-2-9 *Connecting the Network Configurator to the Network*.

- 1,2,3...**
1. Connect the Network Configurator to the network.
  2. Select the icon of the EtherNet/IP Unit in which you want to clear the device parameters. In the following example, 2 nodes are selected: 192.168.250.1 and 192.168.250.2. To select multiple nodes, press and hold the Shift Key while selecting additional icons.

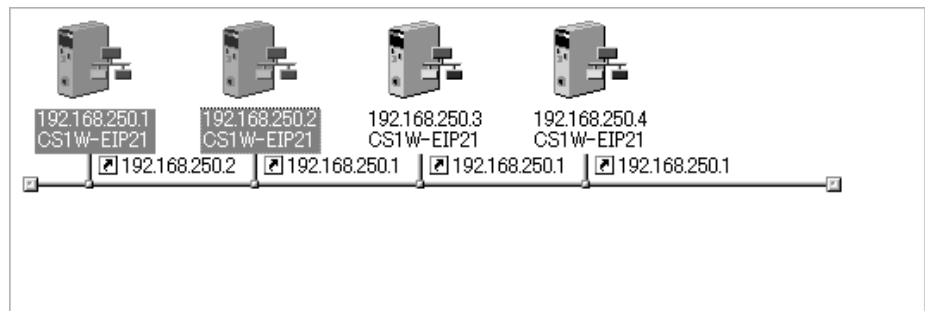

3. Select **Device - Reset**. The following dialog box will be displayed.



- Clicking the **Yes** Button:  
The following dialog box will be displayed.

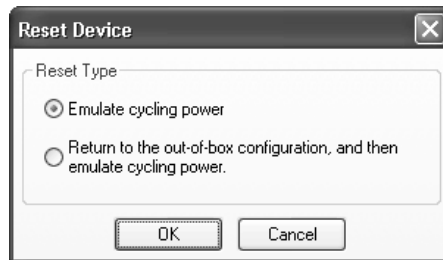

Select one of the following options and click the **OK** Button.

- *Emulate cycling power*  
Restarts the Unit.
- *Return to the out-of-box configuration, and then emulate cycling power*  
Returns the Unit to its factory default settings, and restarts the Unit.
- Clicking the **No** Button:  
The device parameters are not cleared or reset.

## 6-2-15 Saving the Network Configuration File

Device parameters set in the Network Configurator, or device parameters uploaded from the network can be saved as a network configuration file.

- 1,2,3... 1. Select **File - Save As**. The following dialog box will be displayed.

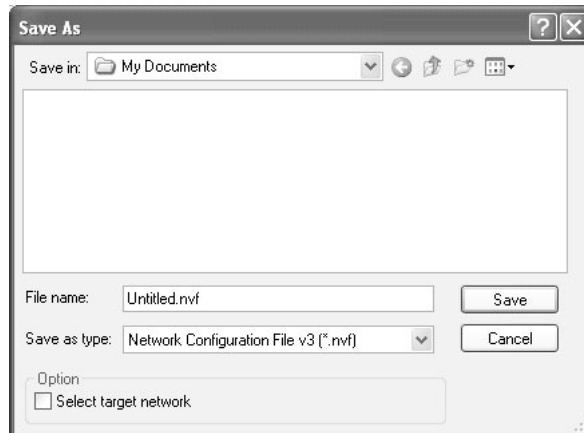

The *File name* Field will contain *Untitled.nvf* as the default file name.

2. Input the file name, and click the **Save** Button.

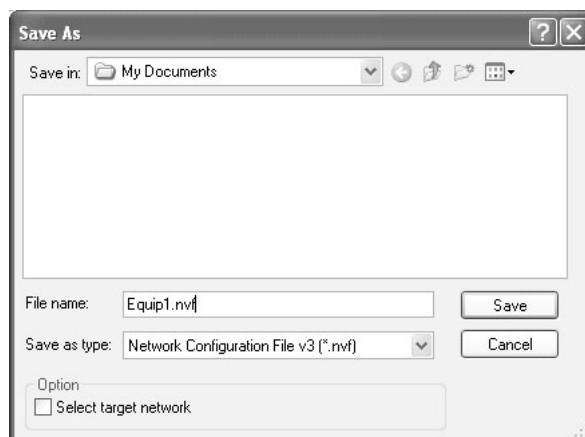

The network configuration file save operation is complete.

- When the network configuration is changed later, the existing network configuration file can be overwritten by selecting **File - Save** or clicking the  Button.
- You can select the *Select target network* Check Box in the *Option* Area to save a network configuration file with only the required networks.

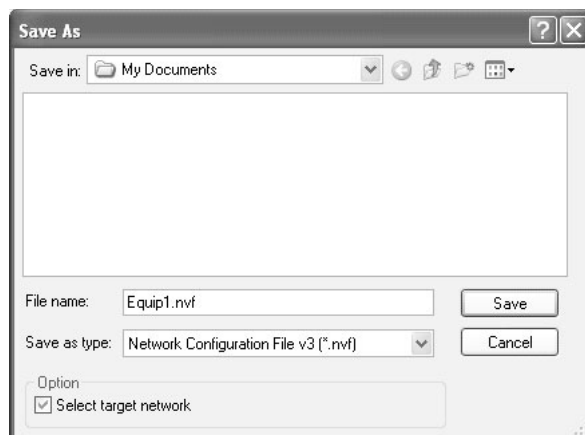

Select the check boxes of the networks to save and click the **OK** Button.

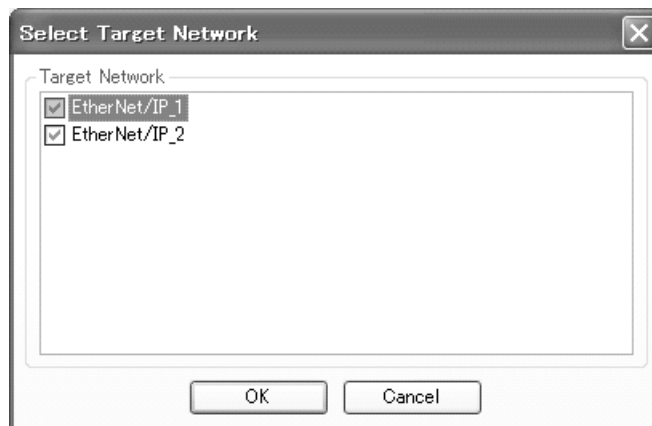

## 6-2-16 Reading a Network Configuration File

A previously saved network configuration file can be read into the Network Configurator.



- 1,2,3... 1. Select **File - Open** or click the  Button. The following dialog box will be displayed.

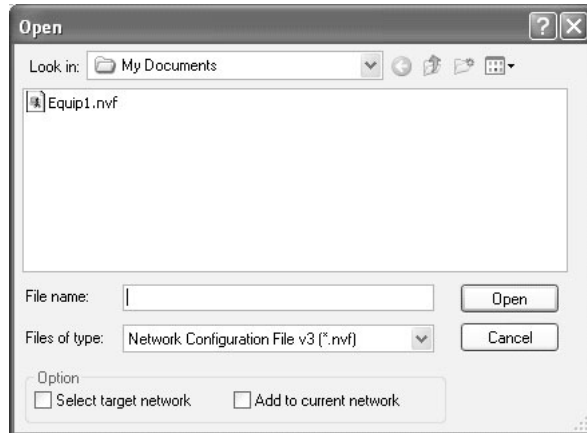

If the network configuration file that you want to read is not displayed, change to (*Look in*) another folder.

2. When you click and select the network configuration file that you want to read, that file name will be displayed in the *File name* Field.

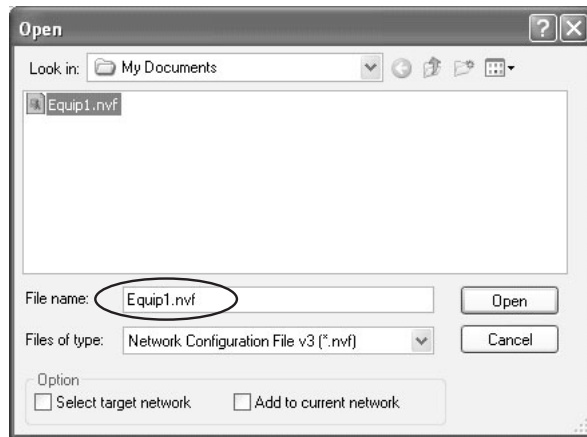

3. Click the **Open** Button to read the network configuration file.  
 4. The Network Configurator's Title Bar will display the name of the file that was read.

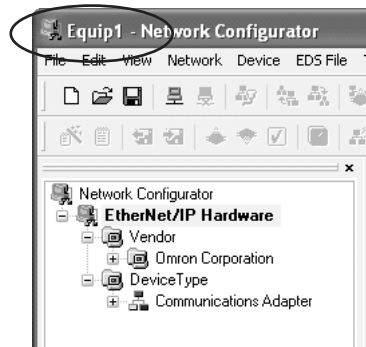

5. Select any of the options as necessary. The options are listed below.

Option	Function
Select target network	Allows you to select specific networks from the network configuration and open them.
Add to current document	Allows you to add the networks from the network configuration file being opened to the current configuration file.

**Note** The save format will vary depending on the Network Configurator version. Configuration files (\*.ncf) created using the Network Configurator for EtherNet/IP (version 2 or higher) can be imported (opened) by selecting **External Data - Import** from the File Menu.

### 6-2-17 Checking Connections

Check the consistency of connection parameters for network configuration files with device parameters set using the Network Configurator and device parameters uploaded from the network.



1. Select *Check Connections* in the Network Menu. The following dialog box will be displayed if parameters are normal.

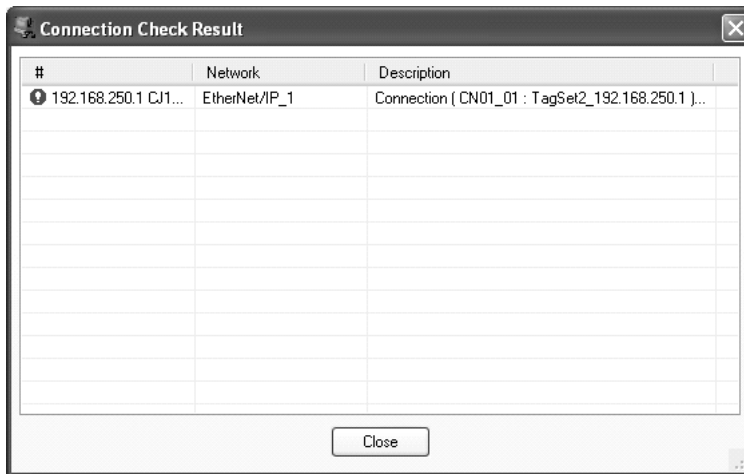

The following dialog box will be displayed if there are parameter errors. Check the displayed details and review the settings.



If an inconsistency occurs, open the originator's Edit Device Parameter Dialog Box and click the **Connection** Tab. The inconsistent connection will

be displayed with a  icon (instead of the normal  icon). To change the connection setting and select a different target variable, select the connection as shown below and click the **Edit** Button.

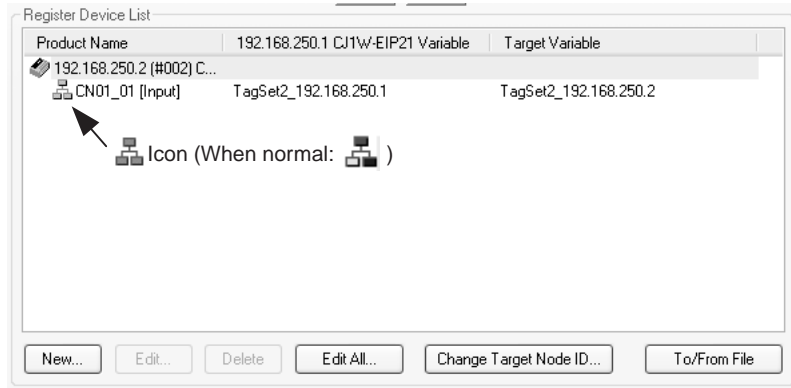

### 6-2-18 Changing Devices

Devices that are registered in a network configuration with the Network Configurator can be changed. Select **Change Device** from the Device Menu to display a list of the devices that can be changed to. Select the desired device.

A device can be changed only when there is complete or upward compatibility with the device being changed to.

#### Device Changes

Device after change		CJ1W-EIP21	CS1W-EIP21	CJ1W-EIP21	CS1W-EIP21	CJ1W-EIP (CJ2)	CJ2B-EIP21	CJ2M-EIP21
Device before change	Revision	1.01	1.01	2.01	2.01	2.01	2.01	2.01
<b>CJ1W-EIP21</b>	1.01	---	OK	OK	OK	OK	OK	OK if there are less than 33 tags
<b>CS1W-EIP21</b>	1.01	OK	---	OK	OK	OK	OK	OK if there are less than 33 tags
<b>CJ1W-EIP21</b>	2.01	No	No	---	OK	OK	OK	OK if there are less than 33 tags
<b>CS1W-EIP21</b>	2.01	No	No	OK	---	OK	OK	OK if there are less than 33 tags
<b>CJ1W-EIP (CJ2)</b>	2.01	No	No	OK if no variables in tags	OK if no variables in tags	---	OK	OK if there are less than 33 tags
<b>CJ2B-EIP21</b>	2.01	No	No	OK if no variables in tags	OK if no variables in tags	OK	---	OK if there are less than 33 tags
<b>CJ2M-EIP21</b>	2.01	No	No	OK if no variables in tags	OK if no variables in tags	OK	OK	---

### 6-2-19 Displaying Device Status

Device status is displayed using the following icons in Maintenance Mode. To enter maintenance mode, select **Large Icons - Maintenance Mode** from the View Menu.

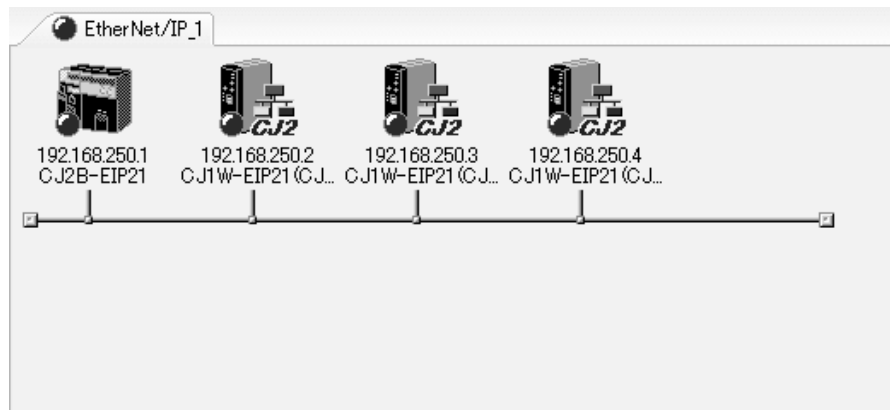

Icon	Status
(gray)	Offline
(turquoise edge)	Default (no configuration)
(green)	Idle (CPU Unit of PLC is in PROGRAM mode.)
(blue)	Communications normal (CPU Unit of PLC is in RUN or MONITOR mode.)
(yellow)	Warning (A non-fatal error has occurred in the CPU Unit of the PLC.)
(red)	Alarm (A fatal error has occurred in the CPU Unit of the PLC.)

## 6-3 Ladder Programming with Tag Data Links

### 6-3-1 Ladder Programming Related to Tag Data Links

If data in the ladder program is linked by tag data links, add conditions 1 to 4 in the ladder program for that data. If you want to use target node PLC flags as input conditions, add conditions 5 and 6.

For details on the various flags, refer to 4-2 *CIO Area Allocations*.

**Conditions showing the EtherNet/IP Unit's Tag Data Links are enabled:**

1. The Unit Error Occurred Flag (n+10, bit 00) is OFF,
2. and the Online Flag (n+11, bit 00) is ON,
3. and the Tag Data Link Operating Flag (n+11, bit 01) is ON.

**Conditions showing that connections are established with the target device, and tag data links are operating:**

4. The corresponding Normal Target Node Flag (in words n+20 to n+23) is ON.

The location of the Normal Target Node Flags depends on the layout setting. For details on the layout settings, refer to 4-2-2 *Details of the Allocated CIO Area Words*.

**Note** With revision 2 or higher, the Normal Target Node Flag will turn ON only after the data for all connections for the target device has been refreshed in the CPU Unit. With revision 1, the Normal Target Node Flag will turn ON after the data for only one connection for the target device has been refreshed in the CPU Unit.

**Condition showing that the Target Node PLC is operating (OMRON PLCs only):**

5. The corresponding Target Node PLC Operating Flag (in words n+2 to n+5) is ON.

**Condition showing the Target Node PLC's fatal or non-fatal error status (OMRON PLCs only):**

6. The corresponding Target Node PLC Error Flag (in words n+6 to n+9) is OFF.

When you want to use the Target Node PLC Error Flag, the PLC status must be included in the tag sets for both the originator and target. Include the PLC status by using the Network Configurator to select the *Include Options* in the Edit Tag Set Dialog Boxes. For details, refer to 6-3-2 *Status Flags Related to Tag Data Links*.

**Example of Programming to Detect Normal Status**

The following programming can be used to confirm that normal communications are being performed for each target node. If the PLC status is included in the tag data, the status of the PLC can also be detected.

**Programming for Revision 2 or Higher**

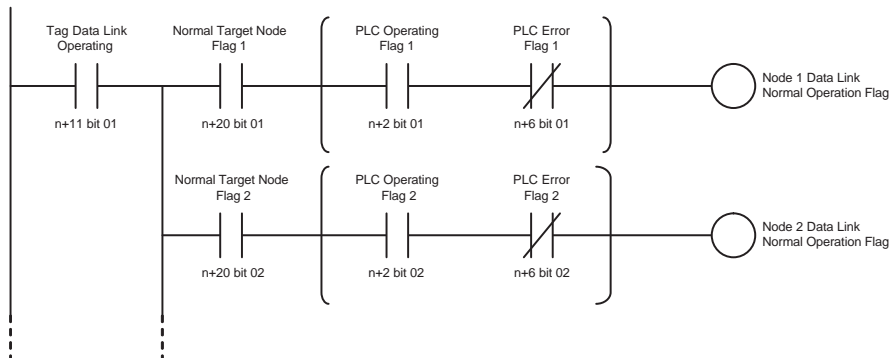

**Programming for Revision 1 and Revision 2**

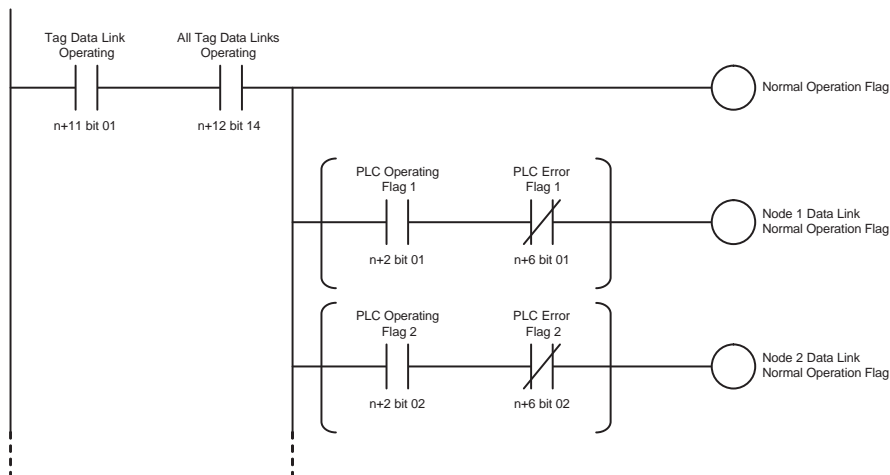

**Programming to Detect Errors: Example 1**

The following programming can be used to check for errors for each target node. This programming is used to detect errors only after the data links for all nodes have started normally.

**Programming for Revision 2 or Higher**

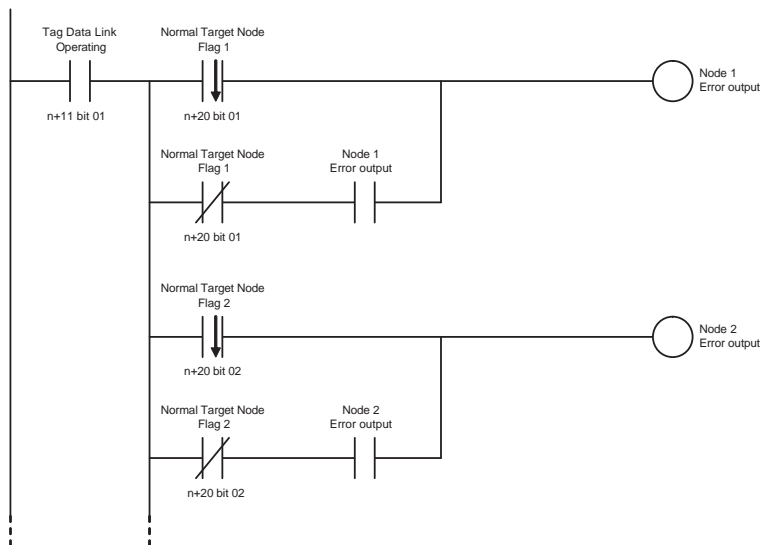

**Programming to Detect Errors: Example 2**

The following programming can be used to detect tag data link errors at the local node.

Programming for Revision 1 or Higher

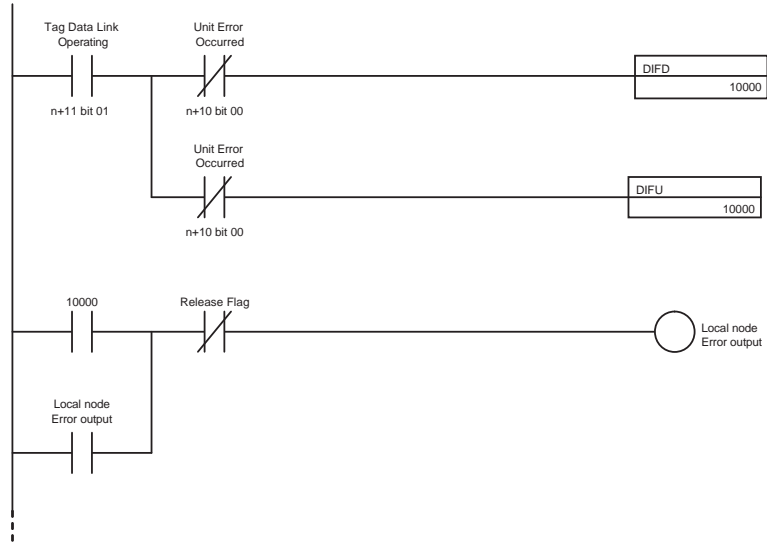

Example of Programming to Process Data

The following type of programming can be used to process data only when the data links are operating normally.

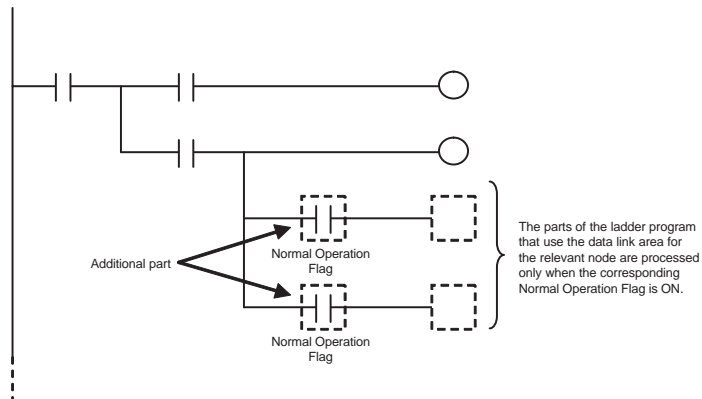

Interlocks (IL and ILC instructions) and jumps (JMP and JME instructions) can also be used to process data only when the data links are operating normally as shown below.

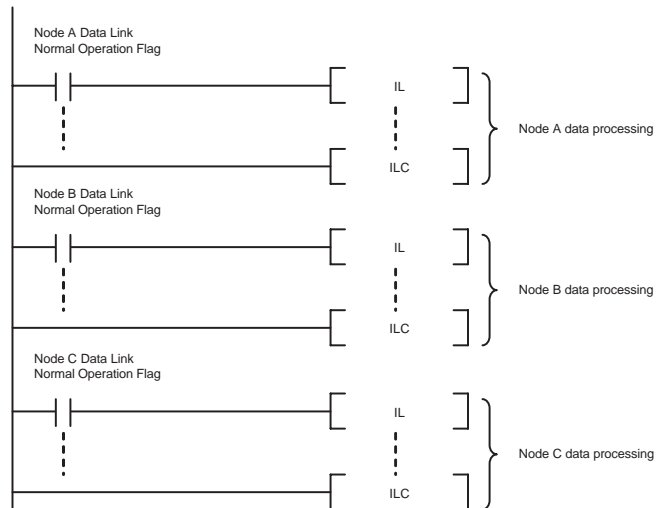

**Note** Even if an error occurs in communications with a target device, the input data from the target device will remain stored in words allocated in memory to the local node. To prevent malfunctions, write the ladder program so that input data processing will not be performed when the Unit Error Occurred Flag (word n+10 bit 00) is ON.

### 6-3-2 Status Flags Related to Tag Data Links

The status of the tag data links is reflected in the following words.

Name (allocated area)	Contents
<p>Target Node PLC Operating Flag Information                      Layout set to default settings:                      Words n+2 to n+5                      Layout set to user settings:                      Words n+32 to n+47</p> <p><b>Note</b> Corresponds to the PLC status's PLC Operating Flag.</p>	<p>Each flag indicates the operating status of the corresponding target node PLC of connections in which the EtherNet/IP Unit is the originator. The flag corresponding to the target node's target ID will be ON when the PLC Operating Flags for all connections with that target node indicate that the PLC is operating.</p> <p>Each node address's flag location (i.e., target ID) can be changed from the Network Configurator. The PLC status flags are enabled when the PLC status is included in the communications data for both the originator and target.</p> <p>The data in this table is refreshed when necessary.</p>
<p>Target Node PLC Error Flag Information                      Layout set to default settings:                      Words n+6 to n+9                      Layout set to user settings:                      Words n+48 to n+63</p> <p><b>Note</b> Corresponds to the PLC status's PLC Error Flag.</p>	<p>Each flag indicates the error status (logical OR of non-fatal and fatal errors) of the corresponding target node PLC of connections in which the EtherNet/IP Unit is the originator. The flag corresponding to the target node's target ID will be ON if even one error is indicated in any of the connections with that target node.</p> <p>Each node address's flag location (i.e., target ID) can be changed from the Network Configurator. The PLC status flags are enabled when the PLC status is included in the communications data for both the originator and target.</p> <p>The data in this table is refreshed when necessary.</p>
<p>Normal Target Node Flag Table                      Layout set to default settings:                      Words n+20 to n+23                      Layout set to user settings:                      Words n+16 to n+31</p> <p><b>Note</b> Does not correspond to the PLC status.</p>	<p>Each flag indicates the connection status of the corresponding target node PLC of connections in which the EtherNet/IP Unit is the originator. The flag corresponding to the target node's target ID will be ON when connections are established for all connections with that target node indicate that the PLC is operating.</p> <p>Each node address's flag location (i.e., target ID) can be changed from the Network Configurator. The data in this table is refreshed when necessary.</p>



# SECTION 7

## Message Communications Functions

This section describes message communications using FINS messages and explicit messages.

7-1	Overview . . . . .	190
7-2	FINS Message Communications . . . . .	192
7-3	Explicit Message Communications . . . . .	194
7-4	Message Communications Specifications . . . . .	195
7-5	Message Communications Error Indications . . . . .	196
7-6	Message Communications Errors . . . . .	197

## 7-1 Overview

The message communications functions send command/response messages between nodes on the Ethernet network. The messages can be sent between a computer and PLC, between two PLCs, between an OMRON PLC and a master made by another company, or between slaves. The messages can be used to send/receive data; read time data, error logs, and other data; or control operation, e.g., by force-setting/resetting bits.

There are two types of messages: FINS messages and explicit messages.

Item	FINS messages	Explicit messages
Outline	Message communications for OMRON products that use the FINS protocol.	Standard ODVA message communications using the CIP protocol.
Remote device	<ul style="list-style-type: none"> <li>• Computer with an Ethernet interface</li> <li>• OMRON PLCs (with a CS/CJ-series EtherNet/IP Unit, built-in EtherNet/IP port, or Ethernet Unit)</li> </ul>	<ul style="list-style-type: none"> <li>• Computer with an Ethernet interface</li> <li>• Another company's masters or slaves.</li> <li>• OMRON PLCs (with a CS/CJ-series EtherNet/IP Unit or built-in EtherNet/IP port)</li> </ul>
Features	<ul style="list-style-type: none"> <li>• Send and receive the various FINS commands to provide an even greater range of services than the CIP UCMM messages.</li> <li>• Provide transparency in message communications with other OMRON networks, such as Controller Link, SYSMAC LINK, and Ethernet. (CS1/CJ1 CPU Units with unit version 2.0 or later or CJ2 CPU Units: Up to 8 levels, CPU Units with unit version earlier than 2.0: Up to 3 levels)</li> </ul>	<ul style="list-style-type: none"> <li>• Supports message communications with other companies' EtherNet/IP devices.</li> </ul> <p>CS/CJ Series</p> <ul style="list-style-type: none"> <li>• CS1W-EIP21</li> <li>• CJ1W-EIP21</li> <li>• CJ2H-CPU□□-EIP</li> <li>• CJ2M-CPU3□</li> </ul>

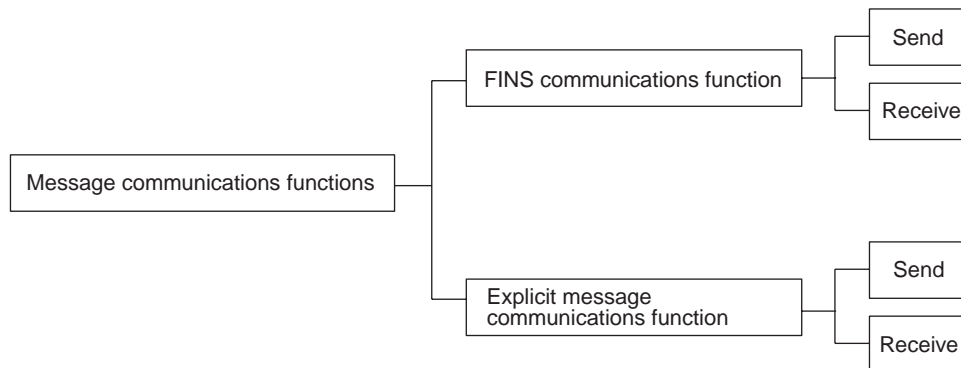

Overall Structure

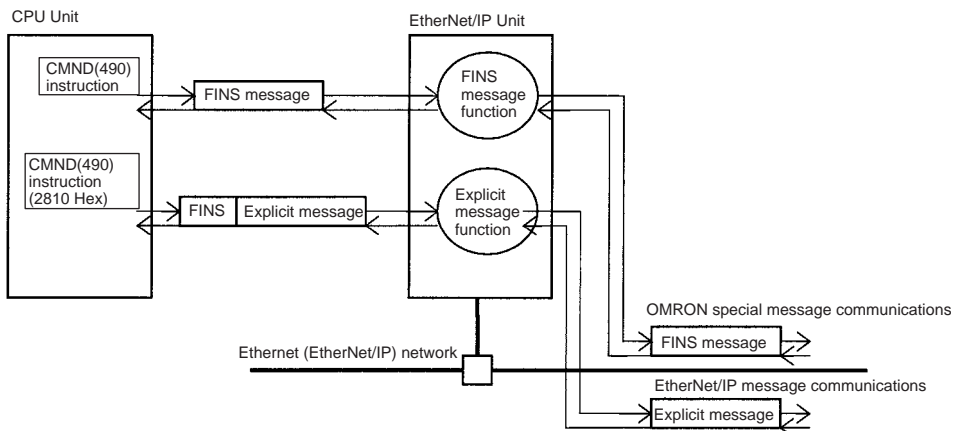

**Note** With the EtherNet/IP Unit or built-in EtherNet/IP port, message communications are possible even if the I/O link function is disabled.

## 7-2 FINS Message Communications

Messages containing FINS commands can be exchanged over the Ethernet network between nodes that support FINS messages.

**Note** FINS message communications can be executed without any particular restrictions over the Ethernet network with OMRON Ethernet Units (CS1W-ETN21 or CJ1W-ETN21), computers (CX-One or Fins Gateway applications), and NS-series Programmable Terminals.

Type of FINS message	Data send/receive commands	Any kind of FINS command
<b>Network communications instructions</b>	<b>SEND/RCV instructions</b>	<b>CMND(490) instructions</b>
PLC to PLC (both must be CS/CJ-series PLCs with a CS/CJ-series EtherNet/IP Unit, built-in EtherNet/IP port, or Ethernet Units) (See note 1.)  <b>Note</b> Inter-network communications are possible with Ethernet networks or other networks, such as Controller Link. (See note 2.)		
Data length (excluding command code)	SEND instruction: 990 words: RCV instruction: 990 words.	CMND instruction: 1,990 bytes max.

- Note**
1. When two or more Communications Units (including the EtherNet/IP Units and built-in EtherNet/IP ports) are mounted to a CS/CJ-series PLC and FINS messages are being used, the EtherNet/IP Units and built-in EtherNet/IP ports must be registered in the CS/CJ-series PLC's local network routing table. The commands will not be sent if the Unit is not registered in the routing tables.
  2. When a CS/CJ-series EtherNet/IP Unit or built-in EtherNet/IP port is connected to an Ethernet network, message communications can be conducted between networks, including other Ethernet networks as well as other networks such as Controller Link and SYSMAC LINK. Up to eight levels of networks can be crossed, provided that routing tables (containing local network tables and relay network tables) have been registered in the CPU Units of each PLC on the network.
  3. A Programming Device connected to the CPU Unit of a PLC connected to the network can be used to program and monitor another PLC that is on the network. Up to eight levels of networks can be crossed for CS1/CJ1-series CPU Units with unit version 2.0 or later, CJ2 CPU Units, and CX-Programmer version 4.0 or higher.

Up to 8 network levels, including the EtherNet/IP network, can be crossed.

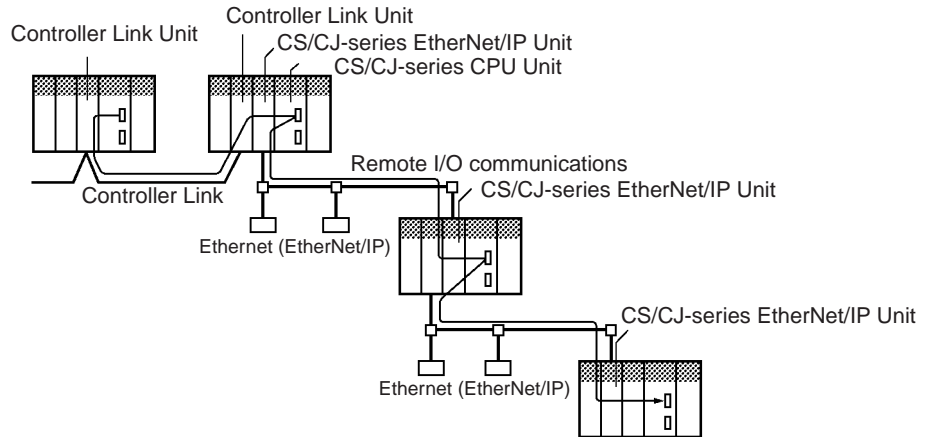

**Note** FINS commands sent and received by the CS/CJ-series EtherNet/IP Unit include commands addressed to the CS/CJ-series CPU Unit and commands addressed to the CS/CJ-series EtherNet/IP Unit.

### 7-3 Explicit Message Communications

Explicit messages defined in EtherNet/IP can be used to send service requests to other companies' EtherNet/IP masters/slaves and OMRON PLCs with CS/CJ-series EtherNet/IP Units and built-in EtherNet/IP ports.

**Note** Specific FINS commands (commands 2810 and 2801) are used to send explicit messages.

Explicit message	Sending	Receiving
Network communications instruction	CIP UCMM messages can be sent to an EtherNet/IP Unit or built-in EtherNet/IP port by a CMND(490) instruction containing FINS command code 2810 Hex.	Automatically responds to explicit messages from other devices.
Functions supported in remote devices	<ul style="list-style-type: none"> <li>• Masters/slaves made by other manufacturers: Supported services determine supported functions.</li> <li>• PLC with a CS/CJ-series EtherNet/IP Unit or built-in EtherNet/IP port: Supports the reading/writing of a remote CPU Unit's status information and I/O memory data.</li> </ul>	<ul style="list-style-type: none"> <li>• Masters made by other manufacturers</li> <li>• PLC with a CS/CJ-series EtherNet/IP Unit or built-in EtherNet/IP port: Supports the reading/writing of the local CPU Unit's status information and I/O memory data.</li> </ul>

**Note** The CS/CJ-series EtherNet/IP Units and built-in EtherNet/IP ports (CS1W-EIP21, CJ1W-EIP21, CJ2H-CPU□□-EIP, or CJ2M-CPU3□) contain a PLC Object, so that other devices can read/write the I/O memory of the CPU Unit with the built-in EtherNet/IP port or the CPU Unit to which the EtherNet/IP Unit is mounted.

## 7-4 Message Communications Specifications

CPU Unit function		CS/CJ Series
<b>Unit model number</b>		CS1W-EIP21, CJ1W-EIP21, CJ2H-CPU□□-EIP, or CJ2M-CPU3□
<b>Communications instructions</b>	<b>Sending/ receiving data</b>	SEND and RECV instructions
	<b>FINS commands</b>	CMND(490) instruction There are two kinds of FINS commands: commands addressed to the CPU Unit, and commands addressed to the CS/CJ-series EtherNet/IP Unit or built-in EtherNet/IP port.
	<b>Sending Ether-Net/IP CIP UCMM messages</b>	CMND(490) instruction Sends CIP UCMM messages to other companies' masters/slaves, or PLCs with a CS/CJ-series EtherNet/IP Unit or built-in EtherNet/IP port mounted.
<b>Number of destination nodes</b>	<b>FINS message communications</b>	1:N communications
	<b>Explicit message communications</b>	1:N communications Send functions: CIP unconnected (UCMM) communications only Receive functions: CIP unconnected (UCMM) and CIP connected (Class 3) communications
<b>Transmission data length (not including the command code)</b>	<b>FINS message communications</b>	<ul style="list-style-type: none"> <li>• SEND: 990 words (1,980 bytes) max. normally, or 727 words (1,454 bytes) max. when broadcasting</li> <li>• RECV: 990 words (1,980 bytes) max.</li> <li>• CMND: 1,990 bytes max. normally, or 1,462 bytes max. when broadcasting (data after the FINS command code)</li> </ul>
	<b>Explicit message communications</b>	CMND: 492 bytes max.
<b>No. of simultaneous instructions</b>		One each for 8 ports (ports 0 to 7) Refer to <i>Network Instructions</i> in the <i>CS/CJ Series Programmable Controllers Instructions Reference Manual (W474)</i> for information on ports (logical ports).
<b>Response monitoring time</b>		Default setting: 2 s User setting: 0.1 to 6553.5 s
<b>Retries</b>		0 to 15
<b>Internetwork connections</b>	<b>Same network type</b>	Supports internetwork communications between Ethernet networks connected to CS/CJ-series EtherNet/IP Units and built-in EtherNet/IP ports (up to 3 levels).
	<b>Different network type</b>	Supports internetwork communications between the EtherNet/IP network connected to a CS/CJ-series EtherNet/IP Unit or built-in EtherNet/IP port and other networks such as Controller Link or SYSMAC LINK (up to 3 levels).

## 7-5 Message Communications Error Indications

There are two ways to obtain information on communications errors that occur in message communications: checking the EtherNet/IP Unit's error log or checking its indicators.

- 1,2,3...
- Each time a communications error occurs, an error code is placed in an error record in the error log stored in RAM in the EtherNet/IP Unit or CPU Unit with the built-in EtherNet/IP Port. Up to 64 records can be stored in the error log. The time and date that the error occurred are also recorded together.

The error log can be read or cleared from the CPU Unit by sending a FINS command to the EtherNet/IP Unit (Error Log Read/Clear). The contents of the error log can also be monitored from the Configurator.

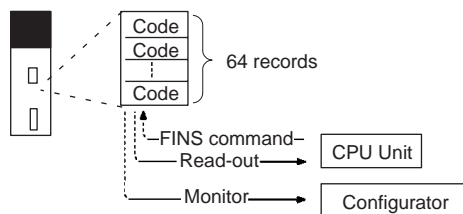

- When a communications error has occurred, details on the error are indicated by the MS and NS indicators and the 7-segment display on the front panel of the EtherNet/IP Unit or CPU Unit with the built-in EtherNet/IP port. This information can be used for troubleshooting.

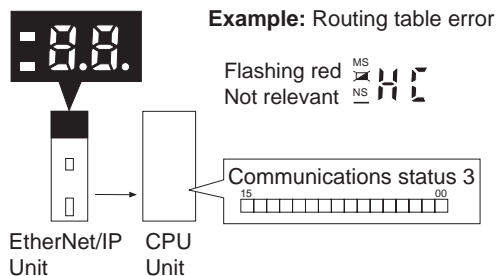



## 7-6 Message Communications Errors

The following table shows the main errors that may occur when messages are sent or received. Refer to *SECTION 14 Troubleshooting and Error Processing* for corrective measures and details on errors that are recorded in error log but not indicated by the LED indicators.

Error	Indicators			Error code (Hex)
	MS	NS	7-segment display (See note.)	
Routing table error	Flashing red	No change	HC	021A
IP address duplication error	No change	Lit red	F0	0211
CPU Unit service monitoring error	Flashing red	No change	HE	0002
Other CPU error		Not lit	H7	0006
Too many retries, cannot send	No change	No change	No change	0103
Node address setting error, cannot send				0105
Remote node not part of network, cannot send				0107
No Unit with specified unit address, cannot send				0108
CPU Unit error occurred, cannot send				010B
Destination address not set in routing tables, cannot send				010D
Routing tables not registered, cannot send				010E
Routing tables error occurred, cannot send				010F
Too many relay connections, cannot send				0110
Maximum command length exceeded, cannot send				0111
Header error; cannot send				0112
Reception buffer full, packet discarded				0117
Invalid packet discarded				0118
Local node busy, cannot send				0119
Unexpected routing error				0120
Service not supported in present mode, packet discarded				0122
Transmission buffer full, packet discarded	0123			
Maximum frame length exceeded, routing impossible	0124			
Packet discarded due to response time-out	0125			

**Note** The 7-segment display alternately displays the error and the node address of the node where the error occurred.



# SECTION 8

## FINS Communications

This section provides information on communicating on EtherNet/IP Systems and interconnected networks using FINS commands. The information provided in the section deals only with FINS communications in reference to EtherNet/IP Units or built-in EtherNet/IP ports.

FINS commands issued from a PLC are sent via the SEND(090), RECV(098), and CMND(490) instructions programmed into the user ladder-diagram program. Although an outline of these instructions is provided in this section, refer to the *CS/CJ Series Programmable Controllers Instructions Reference Manual (W474)* for further details on programming these instructions.

8-1	Overview of FINS Communications . . . . .	200
8-1-1	Communications On an Ethernet Network . . . . .	200
8-1-2	Using the FINS/UDP and FINS/TCP Methods . . . . .	201
8-1-3	FINS Communications Service Specifications . . . . .	201
8-2	FINS/UDP Method . . . . .	202
8-2-1	Overview . . . . .	202
8-3	FINS/TCP Method . . . . .	204
8-3-1	Overview . . . . .	204
8-4	Routing Tables . . . . .	209
8-4-1	Routing Table Overview . . . . .	209
8-4-2	Connecting and Using a Peripheral Device for the PLC . . . . .	210
8-4-3	Routing Table Setting Examples . . . . .	211
8-5	Using FINS Applications . . . . .	213
8-5-1	CX-Programmer (CX-Server) . . . . .	213
8-5-2	FinsGateway . . . . .	217
8-6	Communicating between OMRON PLCs . . . . .	222
8-6-1	Communications Specifications . . . . .	222
8-6-2	PLC Communications Data Areas . . . . .	223
8-6-3	Using SEND(090), RECV(098), and CMND(490) . . . . .	224
8-6-4	Writing Programs . . . . .	228
8-6-5	Program Example . . . . .	232
8-7	Precautions on High Traffic in FINS Communications . . . . .	234

# 8-1 Overview of FINS Communications

## 8-1-1 Communications On an Ethernet Network

The EtherNet/IP Units and built-in EtherNet/IP ports support the FINS communications service, which can be used simultaneously with the CIP communications service.

FINS communications data is sent and received as UDP/IP packets or TCP/IP packets.

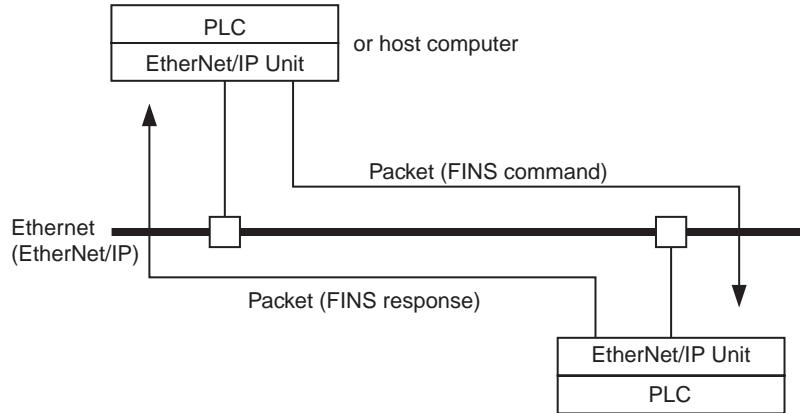

In the FINS communications service, both an IP address for IP (the Internet layer) and a FINS node address for FINS (the application layer) are used for the remote device. Also, 9600 is used as the default setting for the local UDP or TCP port number (i.e., the transport layer) for identifying the application layer, i.e., the FINS communications service. (Another number can be set for the FINS/UDP port from the Setup Tab Page in the Unit Setup.)

For details on pairing FINS node addresses with IP addresses and UDP/TCP port numbers, refer to 5-2 IP Addresses in FINS Communications.

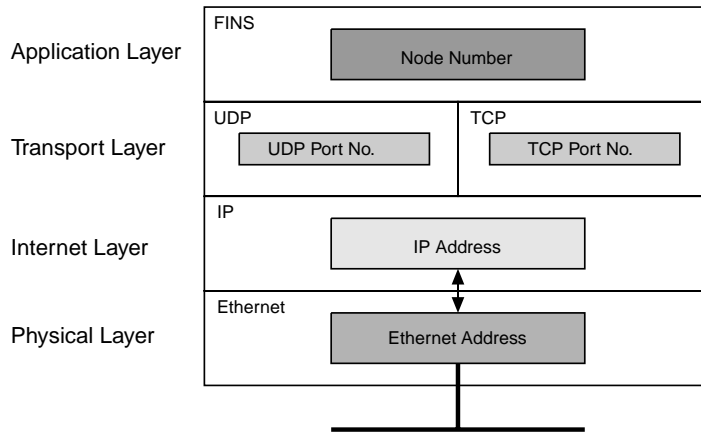

The FINS communications service is a communications method based on UDP/IP, and it is supported by most OMRON Ethernet-related products. (In this manual it is called the FINS/UDP method.) In addition to supporting the FINS/UDP method, the CJ2H-CPU□□-EIP, CJ2M-CPU3□, CS1W-EIP21, and CJ1W-EIP21 support FINS communications using TCP/IP. (In this manual, this is called the FINS/TCP method.)

### 8-1-2 Using the FINS/UDP and FINS/TCP Methods

It is recommended that FINS/UDP and FINS/TCP be used as follows:

- When remote devices do not support the FINS/TCP method:  
Use the FINS/UDP method for FINS communications with those devices.
- When FINS nodes are connected on the same Ethernet segment:  
Use the FINS/UDP method between those nodes.

**Note** FINS/UDP offers a slight advantage in performance.

- When FINS nodes are connected over multiple IP network layers:  
Use the FINS/TCP method between those nodes.

**Note** FINS/TCP offers superior communications quality.

- When the quality of connections is unreliable, as with wireless LAN:  
Use the FINS/TCP method between those nodes.

**Note** FINS/TCP offers superior communications quality.

### 8-1-3 FINS Communications Service Specifications

Item	Specifications	
<b>Number of nodes</b>	254	
<b>Message length</b>	2,012 bytes max.	
<b>Number of buffers</b>	192	
<b>Protocol name</b>	FINS/UDP method	FINS/TCP method
<b>Protocol used</b>	UDP/IP	TCP/IP
<b>Number of connections</b>	---	16
<b>Port number</b>	9600 (default) Can be changed.	9600 (default) Can be changed.
<b>Protection</b>	No	Yes (Specification of client IP addresses when Unit is used as a server)
<b>Other</b>	Items set for each UDP port • Broadcast • IP Address Conversion	Items set for each connection • Server/client specification • Remote IP address specification When client: Specify the IP address of the remote Unit (server). When server: Specify IP addresses of clients permitted to connect. • Automatic FINS node address allocation: Specify automatic allocation of client FINS node addresses. • Keep-alive: Specify whether remote node keep-alive is to be used. TCP/IP Setting • Remote node keep-alive time
<b>Internal table</b>	This is a table of correspondences for remote FINS node addresses, remote IP addresses, TCP/UDP, and remote port numbers. It is created automatically when power is turned ON to the PLC or when the Ethernet Unit is restarted, and it is automatically changed when a connection is established by means of the FINS/TCP method or when a FINS command is received. The following functions are enabled by using this table. • IP address conversion using the FINS/UDP method • Automatic FINS node address conversion after a connection is established using the FINS/TCP method • Automatic client FINS node address allocation using the FINS/TCP method • Simultaneous connection of multiple FINS applications	

# 8-2 FINS/UDP Method

## 8-2-1 Overview

### FINS/UDP Features

The FINS/UDP method is a FINS communications method that uses the UDP/IP protocol. UDP/IP is a connectionless communications protocol. When a message is sent from one node to another, the two nodes have an equal relationship and there is no clear connection. If using TCP is like making a telephone call, then UDP is more like delivering a memo by hand. Although the UDP protocol is fast, data communications are less reliable than with TCP.

In particular, when sending large amounts of data involving significant routing, the user must program measures, such as retries, into applications in order to improve reliability.

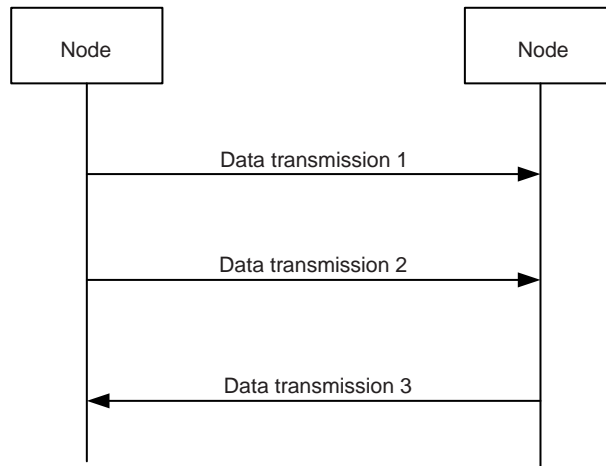

Data is sent in one direction, with no confirmation of whether the data was received. Because there are few procedures involved, data can be sent at high speed but with less reliability than with TCP.

The FINS/UDP method has the following features:

- Because FINS/UDP is a connectionless protocol, there is no limit to the number of corrections.
- FINS/UDP can be used for broadcasting.
- When data is sent via an IP network with multiple layers (such as the Internet), communications reliability drops.

### FINS/UDP Frame Format

The following diagram shows the structure of a UDP packet used for sending and receiving data on an Ethernet network.

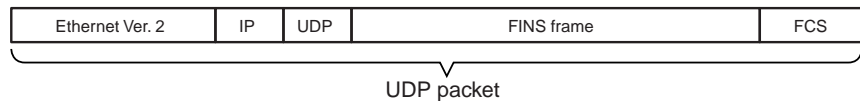

As the diagram shows, a nested structure is used with the FINS/UDP method, i.e., Ethernet Ver. 2, IP frame, UDP frame, and FINS frame. A UDP data section (FINS frame) that exceeds 1,472 bytes is split into packets for transmission. The split UDP data is then joined automatically at the UDP/IP protocol layer. There is normally no need to pay attention at the application layer to this split, but it may not be possible to send 1,472-byte UDP packets over an IP network with multiple layers. When using the FINS communications service in a system such as this, select the FINS/TCP method.

**UDP Port Numbers for FINS/UDP**

The UDP port number is the number for UDP to identify the application layer (i.e., the FINS communications service in this case). When communications are executed by UDP/IP, this port number must be allocated to the communications service.

The default setting for the UDP port number (i.e., the UDP port number of the EtherNet/IP Unit or built-in EtherNet/IP port) is 9600. To set another number, set the number on the FINS/UDP Tab Page of the CX-Programmers Edit Parameters Dialog Box.

At the EtherNet/IP Unit or built-in EtherNet/IP port, a UDP/IP frame received with a FINS/UDP port number is recognized as a FINS frame.

**Procedure for Using FINS/UDP**

- 1,2,3...**
1. Make the basic settings.  
Refer to *Initial Settings in 3-1-1 Procedures*.
  2. Keep the CX-Programmer connected online, right-click the EtherNet/IP Unit or built-in EtherNet/IP port in the PLC IO Table Dialog Box, and select **Edit - Unit Setup**. Set the following in the CPU Bus Unit Setup Area from the FINS/UDP Tab Page of the Edit Parameters Dialog Box.
    - IP Address Conversion
    - FINS/UDP Port No. (Default: 9600)
    - IP Address List (Set only when the conversion method is set to IP address table.)
    - Dynamic Change of remote IP addresses
  3. Select **Transfer to PLC** from the PLC Menu and click the **Yes** Button. The setting data will be transferred to the CPU Bus Unit System Setup Area in the CPU Unit.
  4. Make the routing table settings and transfer them to each PLC. (See note.) Set the routing tables with CX-Integrator, and transfer it to each PLC.
  5. Create a ladder program that includes the SEND(090), RECV(098), and CMND(490) instructions.

**Note** Routing tables are required in the following situations:

- When communicating with a PLC or computer on another network (e.g., remote programming or monitoring using FINS messages or a CX-Programmer).
- When multiple Communications Units are mounted to a single PLC (i.e., CPU Unit).
- When routing tables are used for one or more other nodes on the same network.

It is not necessary to set routing tables if one Communications Unit is mounted to the PLC and the nodes are connected as one network.

## 8-3 FINS/TCP Method

### 8-3-1 Overview

#### FINS/TCP Features

The FINS/TCP method is a FINS communications method that uses the TCP/IP protocol. TCP/IP is a connection-type communications protocol. Before a message is sent from one node to another, it is necessary to establish a virtual circuit, i.e., a connection. Once a connection has been established, communications are quite reliable. The arrival of data that is sent via the connection is confirmed by an acknowledgement (ACK) response, and retries are executed automatically as required.

When FINS/TCP is used, it must be determined which node is the server and which nodes are the clients.

For communications between a personal computer and a PLC, the computer should normally be set as the client and the PLC as the server. For communications between two PLCs, either one can be set as the client and the other as the server.

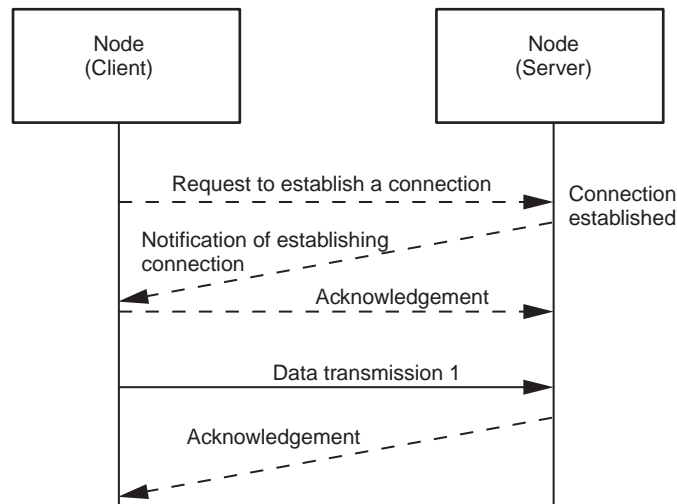

An acknowledgement is received whenever a connection is established or data is sent, so transmissions are more reliable but somewhat slower.

Compared to the FINS/UDP method, the FINS/TCP method has the following characteristics.

- Data transmission is more reliable, due to factors such as retry processing at the TCP/IP layer. The FINS/TCP method is thus better suited to dealing with communications errors in an IP network that spans several layers.
- Remote clients can be restricted by means of settings at the server (i.e., the server can be protected from access by non-specified IP addresses).
- Broadcasting cannot be used.
- TCP/IP has various retry procedures, and this tends to lower its performance in comparison with UDP/IP.
- There is a limit to the number of connections that can be made (i.e., 16 connections maximum), and any given node can communicate only with up to 16 other nodes at a time.



- After a FINS/TCP connection (connection number, remote IP address) has been set in the FINS/TCP Tab Page of the Network Configurator's Edit Parameters Dialog Box, it can be dynamically changed from the ladder program using a FINS command (i.e., FINS/TCP CONNECTION REMOTE NODE CHANGE REQUEST).

**FINS/TCP Frame Format**

The following diagram shows the structure of a TCP packet sent over an Ethernet network.

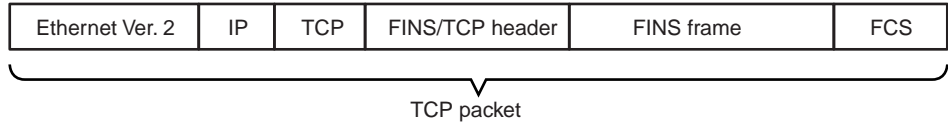

As the diagram shows, a nested structure is used with the FINS/TCP method, i.e., Ethernet Ver. 2, IP frame, TCP frame, FINS/TCP header frame, and FINS frame. A TCP data section (FINS/TCP header + FINS frame) that exceeds the segment size (default setting of 1,024 bytes in the EtherNet/IP Unit or built-in EtherNet/IP port, with automatic adjustment for optimum values between the nodes) is split into TCP packets for transmission. The split TCP data is then joined automatically at the remote node's TCP/IP protocol layer. The TCP/IP protocol layer, however, cannot determine where the data has been split, so the TCP data sections from multiple packets are all joined together. Therefore, when using the FINS/TCP method, FINS/TCP headers must be added at the beginning of FINS frames in order to serve as FINS frame delimiters. The length of the data in the following FINS frame is stored in the header, allowing the frame to be separated out by the remote node. With the EtherNet/IP Unit or built-in EtherNet/IP port and FinsGateway (Ver. 2003 or higher) the appropriate frames are separated out automatically, so there is normally no need to be pay attention to it at the application layer.

**TCP Port Number for FINS/TCP**

The TCP port number is the number for TCP to identify the application layer (i.e., the FINS communications service in this case). When communications are executed using TCP/IP, this port number must be allocated for the communications service.

The default setting for the TCP port number (i.e., the TCP port number of the EtherNet/IP Unit or built-in EtherNet/IP port) is 9600. To set another number, make the setting for the FINS/TCP port on the FINS/TCP Tab Page of the CX-Programmer's Edit Parameters Dialog Box.

The FINS/TCP port number set in the FINS Configuration Tab Page is used by the FINS/TCP server's TCP socket. The FINS/TCP client's TCP socket uses any TCP port number that can be used at that node. (With the EtherNet/IP Unit or built-in EtherNet/IP port and FinsGateway (Ver. 2003 or higher), an unused TCP port is automatically detected and utilized.)

At the EtherNet/IP Unit or built-in EtherNet/IP port, a TCP/IP frame that is received is recognized as a FINS frame, according to the remote TCP port number in the frame.

**FINS/TCP Connection Numbers**

FINS/TCP allows up to 16 FINS/TCP connections to be established simultaneously, and these 16 connections are managed at the EtherNet/IP Unit or built-in EtherNet/IP port by connection numbers. When setting FINS/TCP connection settings in the FINS/TCP Tab Page of the Network Configurator's Edit Parameters Dialog Box, set them individually using these connection numbers.

**FINS/TCP Connection Status (Word n+24)**

While a connection with a remote node is established, the bit corresponding to the FINS/TCP connection status turns ON in the section of the CPU Bus Unit words allocated in the CIO Area. The bit turns OFF if the connection is terminated by a communications error or a FINS command (i.e., FINS/TCP CONNECTION REMOTE NODE CHANGE REQUEST).

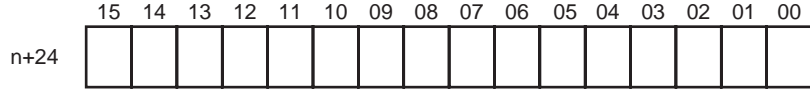

\*: Bit 15 corresponds to connection No. 16, bit 00 to connection No. 1, etc.

**Note** The starting word of the FINS/TCP Connection Status Area is different in the CS1W-ETN21 and CJ1W-ETN21 Ethernet Units; it is n+23 in the Ethernet Units. If a ladder program using FINS/TCP communications was created for Ethernet Units, and is being reused for EtherNet/IP Units and built-in EtherNet/IP ports, change the word starting word address for this area from n+23 to n+24.

**FINS/TCP Communications Procedure**

With FINS/TCP, FINS node addresses are exchanged immediately after a connection is established. This makes it possible to determine the FINS node addresses to which the 16 connection numbers, and to manage them in an internal table.

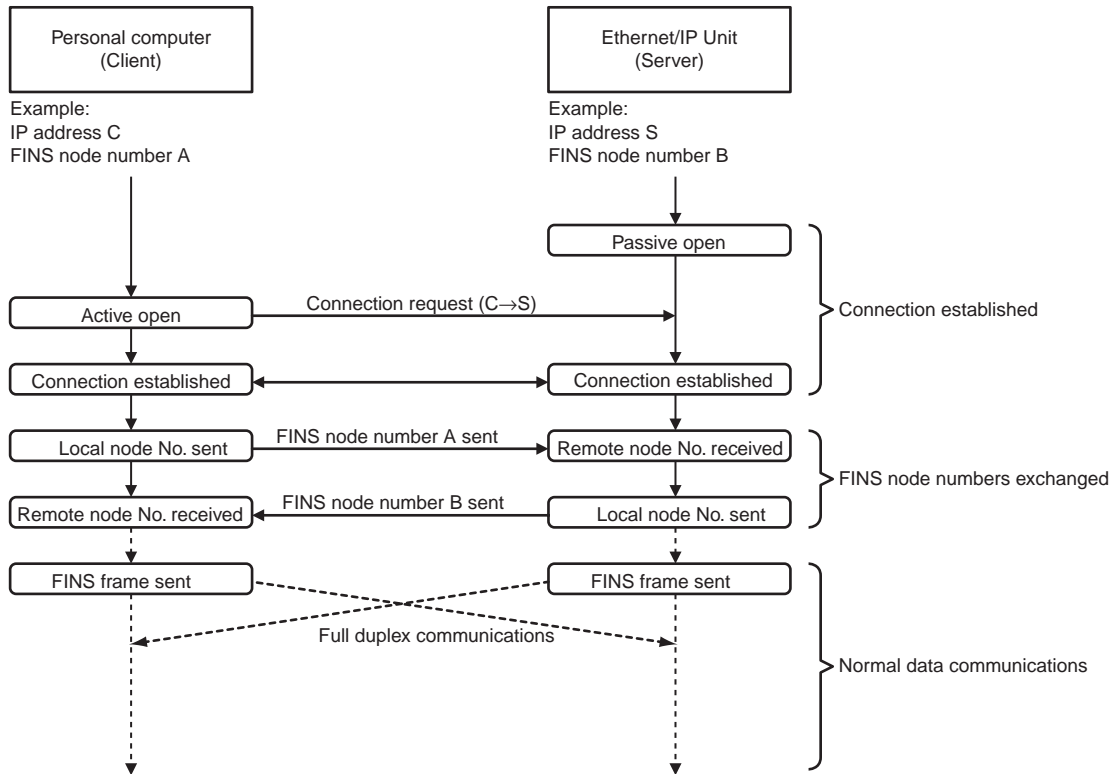

After a connection has been established as a FINS/TCP server, it is terminated in the following ways.

- When the connection is closed by the client.
- When a FINS command to close the connection (FINS/TCP CONNECTION REMOTE NODE CHANGE REQUEST) is sent by the client.
- When there is no response from the client when the keep-alive function is in effect.

After a connection has been established as a FINS/TCP client, it can be terminated in the following ways.

- If the connection is closed by the server.
- If there is no response from the client when the keep-alive function is in effect.

Even if the connection is closed at the FINS/TCP client, requests continue to be made to the FINS/TCP server every few seconds to open a connection.

**Note** After the EtherNet/IP Unit or built-in EtherNet/IP port is powered up or restarted, the IP address for the connection used as the FINS/TCP client is the remote IP address that was set in the FINS/TCP Tab Page of the CX-Programmer's Edit Parameters Dialog Box. To dynamically change the remote IP address (i.e., during CPU Unit operation), execute the CMND(490) instruction in the ladder program and send a FINS command (FINS/TCP CONNECTION REMOTE NODE CHANGE REQUEST; command code: 27 30 hexadecimal) to the EtherNet/IP Unit or built-in EtherNet/IP port.

### Procedure for Using FINS/TCP

- 1,2,3...**
1. Make the basic settings.  
Refer to *Initial Settings* in 3-1-1 Procedures.
  2. Make the following settings on the FINS/TCP Tab Page of the CX-Programmer's Edit Parameters Dialog Box.
    - FINS/TCP port (default: 9600)
    - Server/Client: Specifies whether the connection will operate in FINS/TCP server mode or client mode.
    - Target IP address for client: Specifies the IP address of the target FINS/TCP server.
    - Target IP address for server: Specifies allowed client IP addresses when protection is enabled.
    - Automatically allocated FINS node address for server: Specifies the address to allocate when automatically allocating a FINS node address to the target FINS/TCP client.
    - Keep-alive: Specified whether to use the keep-alive function.  
**Note** Normally this function is used and the option is selected.
    - Enable protect via IP address:  
**Note** Select this option only when protecting as the server.
  3. Select **Transfer to PLC** from the PLC Menu and click the **Yes** Button. The setting data will be transferred to the CPU Bus Unit System Setup Area in the CPU Unit.
  4. Make the routing table settings and transfer them to each PLC. (See note 1.)  
Set the routing tables with CX-Integrator, and transfer it to each PLC.
  5. Create a ladder program that includes the SEND(090), RECV(098), and CMND(490) instructions.

**Note** (1) Routing tables are required in the following situations:

- When communicating with a PLC or computer on another network (e.g., remote programming or monitoring using FINS messages or a CX-Programmer)
- When multiple Communications Units are mounted to a single PLC (i.e., CPU Unit)

- When routing tables are used for one or more other nodes on the same network

It is not necessary to set routing tables if one Communications Unit is mounted to the PLC and the nodes are connected as one network.

- (2) If EtherNet/IP is selected for CX-Programmer communications, FINS message communications and remote programming/monitoring from the CX-Programmer will be possible as long as CIP routing is possible for the entire communications path. Routing tables do not need to be set. If FINS messages are sent from a PLC, however, then routing tables must be set.

## 8-4 Routing Tables

When the FINS communications service is used, routing tables must be created in advance. Routing tables are required in the following circumstances.

- When communicating with a PLC or computer on another network (e.g., remote programming or monitoring using FINS messages or a CX-Programmer)
- When multiple Communications Units are mounted to a single PLC (i.e., CPU Unit).
- When routing tables are used for one or more other nodes on the same network.

It is not necessary to set routing tables if one Communications Unit is mounted to the PLC and the nodes are connected as one network. The routing tables are required not only for nodes communicating via the FINS communications service but also for all relay nodes on the network.

### 8-4-1 Routing Table Overview

The routing tables describe the transmission path for FINS messages when the FINS communications are used. It consists of two tables: A local network table and a relay network table.

#### Local Network Table

The local network table is a table describing the correspondences among unit numbers of the Communications Units and Boards mounted to each node.

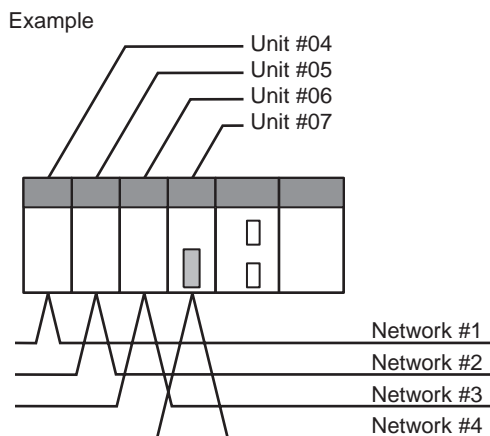

Local Network Table

Local network address	Unit number
1	04
2	05
3	06
4	07

- Note**
1. The unit number is set (0 to F: 1 to 15) using the rotary switch on the front of the EtherNet/IP Unit (built-in port).
  2. The network address is the number of the network (1 to 127) to which the Communications Unit or Board is connected. It is set when the local network table is created.

#### Relay Network Table

A relay table is a table that shows the nodes to which data should be sent first in order to send data to a network that is not connected to the local node. It shows the correspondence between the address of the final destination network, and the network address and node address of the first relay point of the path to reach there. When internetwork communications are carried out, the end network can be reached by following the relay points.

The following example shows routing tables for sending data from PLC #1 (the local node: network address 1, node address 1) to PLC #4 (the destination node: network address 3, node address 2).

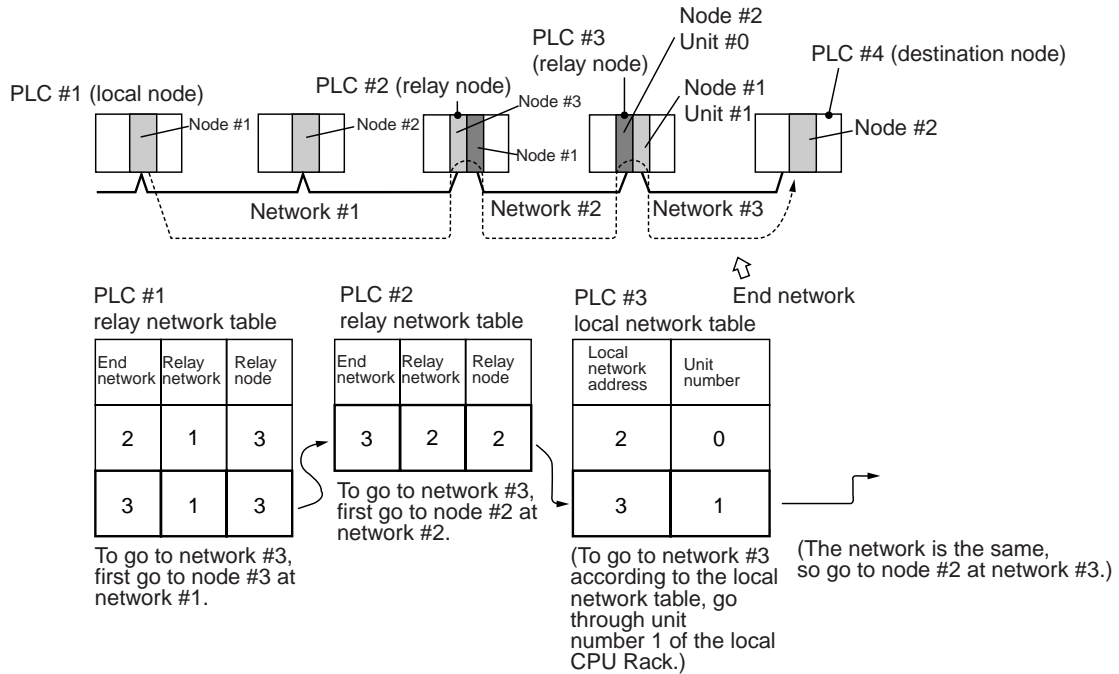

**Note** In the above example, the routing tables required for a message to reach PLC #4 from PLC #1 are shown. Additional settings would be required in the routing tables for a message to reach PLC #1 from PLC #4. Refer to 8-4-3 *Routing Table Setting Examples* for routing table setting examples.

### 8-4-2 Connecting and Using a Peripheral Device for the PLC

Routing tables must be created by a CX-Integrator connected to the PLC. (They cannot be created using a Programming Console.) For details on how to connect and use the CX-Integrator, refer to the *CX-Integrator Operation Manual* (W445). (CX-Integrator is automatically installed when CX-One is installed.)

- Note**
1. When routing tables are transferred from the CX-Integrator to the PLC, all of the CPU Bus Unit are reset so that the routing tables that have been created can be read and enabled. Before transferring the routing tables, confirm that there will be no problems in the system when the CPU Bus Units are reset.
  2. To transfer routing tables for multiple nodes to a PLC in one batch, connect the CX-Integrator to a PLC with only one Communications Unit mounted. Routing tables cannot be transferred to other nodes from a PLC with multiple Communications Units mounted.
  3. Routing tables can only be transferred as a batch to multiple nodes within the same network as the PLC to which the CX-Integrator is connected.

### 8-4-3 Routing Table Setting Examples

■ **Example 1: Local Network Table for a PLC With Multiple Units Mounted**

This example shows the local network table settings for a PLC to which multiple CPU Bus Units are mounted.

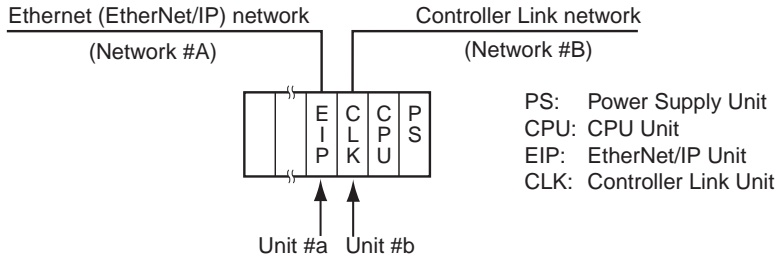

Local Network Table

No.	Local network	CPU Bus Unit
1	A	a
2	B	b

■ **Example 2: Three Interconnected Networks**

This example shows the relay network table settings for three different interconnected networks.

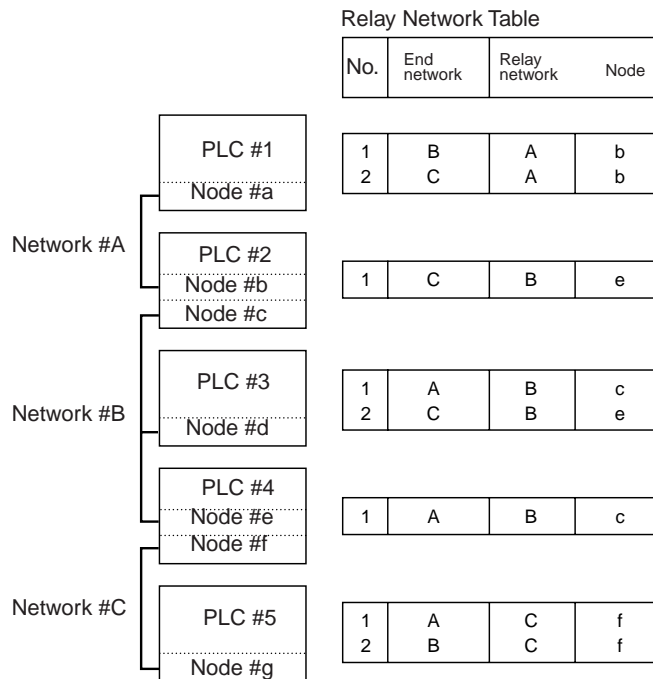

In the table for PLC #3, for example, if network #A is taken as the end network, then network #B becomes the relay network and node #c becomes the relay node. If network #C is taken as the end network, then network #B still becomes the relay network and node #e becomes the relay node.

■ Example 3: All Nodes

This example uses the following configuration to show the routing tables for all nodes.

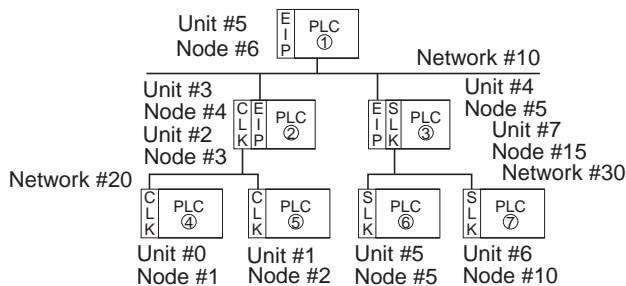

PLC #1 Routing Table  
(Local network table)

No.	Local network	CPU Bus Unit No.
1	010	05
2		
3		

(Relay network table)

No.	End network	Relay network	Relay node
1	020	010	004
2	030	010	005
3			

PLC #2 Routing Table  
(Local network table)

No.	Local network	CPU Bus Unit No.
1	010	03
2	020	02
3		

(Relay network table)

No.	End network	Relay network	Relay node
1	030	010	005
2			
3			

PLC #3 Routing Table  
(Local network table)

No.	Local network	CPU Bus Unit No.
1	010	04
2	030	07
3		

(Relay network table)

No.	End network	Relay network	Relay node
1	020	010	004
2			
3			

PLC #4 Routing Table  
(Local network table)

No.	Local network	CPU Bus Unit No.
1	020	00
2		
3		

(Relay network table)

No.	End network	Relay network	Relay node
1	010	020	003
2	030	020	003
3			

PLC #5 Routing Table  
(Local network table)

No.	Local network	CPU Bus Unit No.
1	020	01
2		
3		

(Relay network table)

No.	End network	Relay network	Relay node
1	010	020	003
2	030	020	003
3			

PLC #6 Routing Table  
(Local network table)

No.	Local network	CPU Bus Unit No.
1	030	05
2		
3		

(Relay network table)

No.	End network	Relay network	Relay node
1	010	030	015
2	020	030	015
3			

PLC #7 Routing Table  
(Local network table)

No.	Local network	CPU Bus Unit No.
1	030	06
2		
3		

(Relay network table)

No.	End network	Relay network	Relay node
1	010	030	015
2	020	030	015
3			



## 8-5 Using FINS Applications

### 8-5-1 CX-Programmer (CX-Server)

The following examples show how to connect online from a CX-Programmer on an Ethernet network to a PLC on the Ethernet network.

#### ■ System Configuration Example 1: No Routing

In this example, an online connection is made by FINS/UDP to a PLC on an Ethernet network (PLC1 in the diagram below) from a CX-Programmer/CX-Integrator connected to the Ethernet network.

Conditions

- FINS/UDP method
- IP Address Conversion: Automatic (Dynamic) generation method

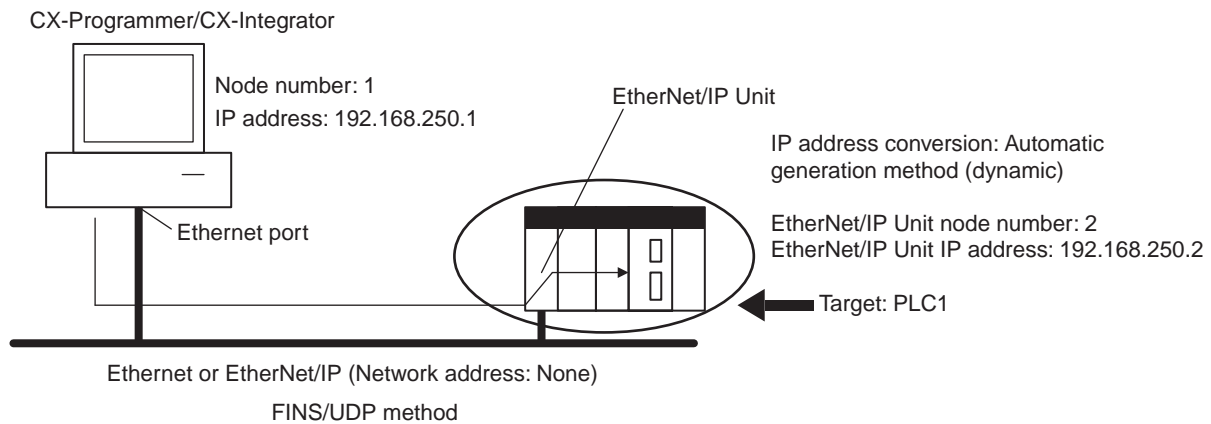

#### CX-Programmer's Change PLC Dialog Box

Settings for target PLC (PLC1)'s Change PLC Dialog Box		Setting	
PLC name		PLC1	
Network classification		Ethernet	
Network Tab Page	FINS transmission source address	0	
	FINS destination	Network number	0
		Node address	2
	Frame length	2,000 bytes	
	Response monitor time	2 seconds	
Driver Tab Page	Workstation node address	1	
	Automatic generation method	Not selected	
	IP address	192.168.250.2 (EtherNet/IP Unit or built-in EtherNet/IP port IP address)	
	Port number	9600	

#### CX-Programmer's FINS/UDP Tab Page in Edit Parameters Dialog Box

Item	Setting
FINS/UDP Port	Default (9600)
IP Address Conversion	Automatic (Dynamic) generation method
IP Router Table	None

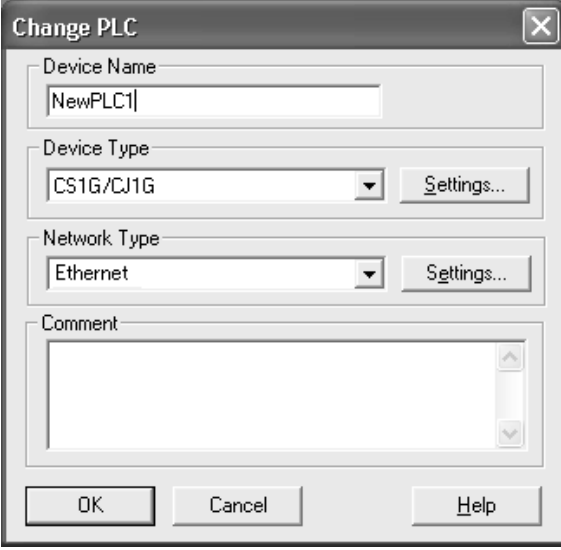
**Example: Inputs to the CX-Programmer's Setup Window****Example: Change PLC Settings**

The "Change PLC" dialog box contains the following fields and controls:

- Device Name:** A text input field containing "NewPLC1".
- Device Type:** A dropdown menu showing "CS1G/CJ1G" and a "Settings..." button.
- Network Type:** A dropdown menu showing "Ethernet" and a "Settings..." button.
- Comment:** A large empty text area with scrollbars.
- Buttons:** "OK", "Cancel", and "Help" buttons at the bottom.

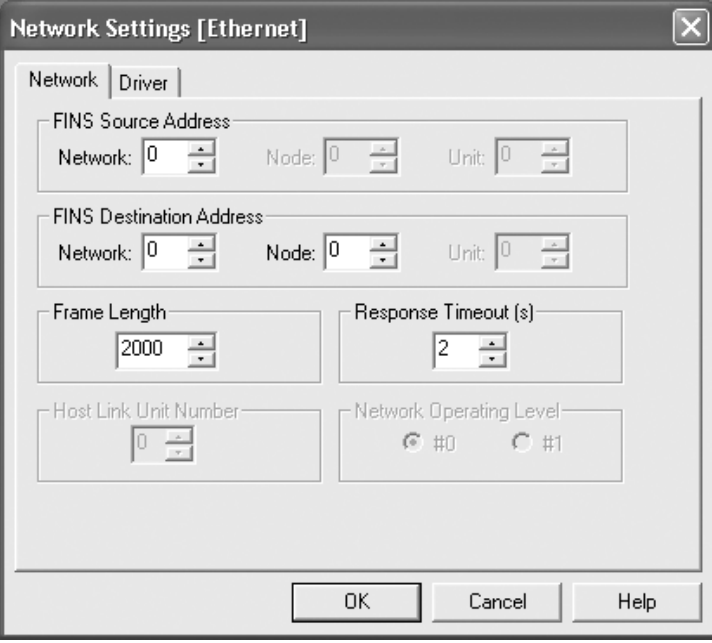
**Example: Network Settings (Network Tab Page)**

The "Network Settings [Ethernet]" dialog box has two tabs: "Network" and "Driver". The "Network" tab is active and contains the following settings:

- FINS Source Address:** Network: 0, Node: 0, Unit: 0.
- FINS Destination Address:** Network: 0, Node: 0, Unit: 0.
- Frame Length:** 2000.
- Response Timeout (s):** 2.
- Host Link Unit Number:** 0.
- Network Operating Level:** Radio buttons for #0 (selected) and #1.
- Buttons:** "OK", "Cancel", and "Help" buttons at the bottom.

**Note** When FinsGateway is selected as the network type, make sure that the frame length is set to 2,000 bytes max.

**Example: Network Settings (Driver Tab Page)**

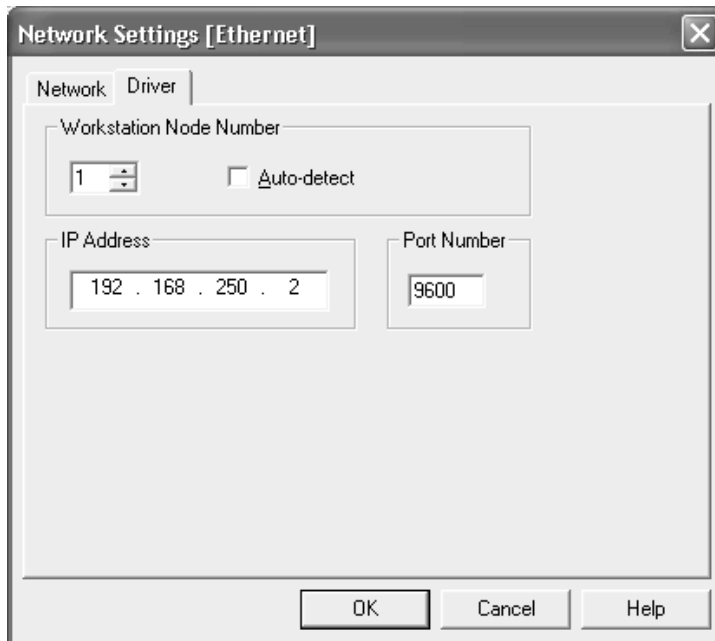

■ **System Configuration Example 2: Using Routing Tables**

In this example, an online connection is made via the Ethernet to a PLC on a Controller Link network (PLC 3 below) from a CX-Programmer/CX-Integrator connected to the Ethernet network.

Conditions

- FINS/UDP method
- IP address conversion: Automatic generation method (dynamic)

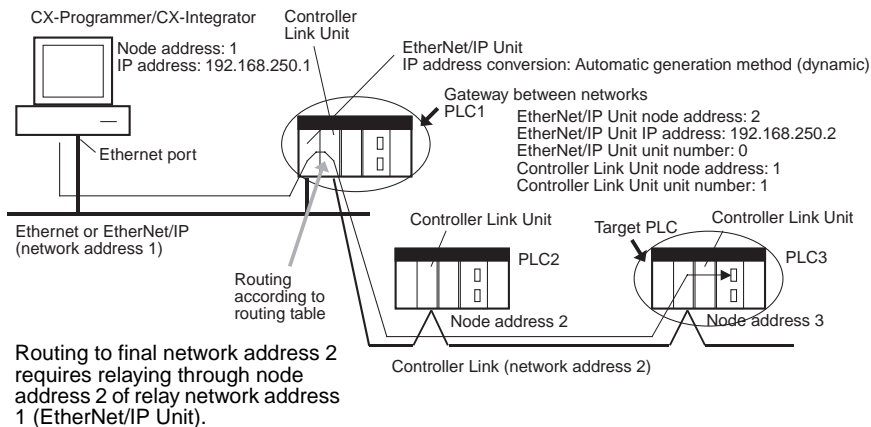

**CX-Programmer's Change PLC Dialog Box**

Settings for target PLC (PLC3)'s Change PLC Dialog Box			Setting
PLC name			PLC3
Network classification			Ethernet
Network Tab Page	FINS destination	FINS transmission source address	1
		Network number	2
		Node address	3
	Frame length		2,000 bytes
	Response monitor time		2 seconds

Settings for target PLC (PLC3)'s Change PLC Dialog Box		Setting
Driver Tab Page	Workstation node address	1
	Automatic generation method	Not selected
	IP address	192.168.250.2 (EtherNet/IP Unit or built-in EtherNet/IP port IP address)
	Port number	9600

**CX-Programmer's FINS/UDP Tab Page in Edit Parameters Dialog Box**

Same as for *System Configuration Example 1*.

**Routing Table Settings and Transfer to Each PLC**

Set the routing tables with CX-Integrator, and transfer them.

- Using CX-Integrator, connect online, and select **Routing table – Settings**. Then create FINS local routing tables (a local network table and a relay network table).

Example: PLC 1 Routing Table Settings

- Local Network Table

Unit number	Local network number
0	1
1	2

- Relay Network Table

None

Example: PLC 2 and PLC 3 Routing Table Settings

- Local Network Table

Unit number	Local network number
0	2

- Relay Network Table

In order to relay from PLC2/3 to the final network number 1, it is necessary to relay via node address 1 (i.e., the Controller Link Unit) on relay network number 2.

Final network number	Relay network number	Relay node address
1	2	1

- Save the routing table file (File - Save local routing table file).
- Next, to connect online, select **Communication Settings** from the Network Menu. For each PLC, register a PLC with a direct serial connection (node address: 0), and select it.
- With the CX-Integrator, select **Work Online** from the Network Menu.
- Select **Tools - Start Routing table**, read the saved file, and select **Options - Transfer to PLC**. Click Yes to transfer the routing tables to the connected PLC.

## 8-5-2 FinsGateway

FinsGateway Ver. 2003 must be used to communicate using FINS/TCP between applications serving as communications drivers and CS1W-EIP21, CJ1W-EIP21, CJ2H-CPU□□-EIP, or CJ2M-CPU3□ EtherNet/IP Units.

FinsGateway Ver. 3.□ or lower versions can be used, however, when communicating by the FINS/UDP method only.

### ■ Overview of Setup Methods

#### 1. Starting FinsGateway Settings

Select **FinsGateway – FinsGateway Setup** to start the FinsGateway Setup.

#### 2. ETN\_UNIT Driver Setup

1. Double-click on **ETN\_UNIT** in the settings for the network and Unit. The following ETN\_UNIT Properties Window will be displayed.

- Network Tab Page

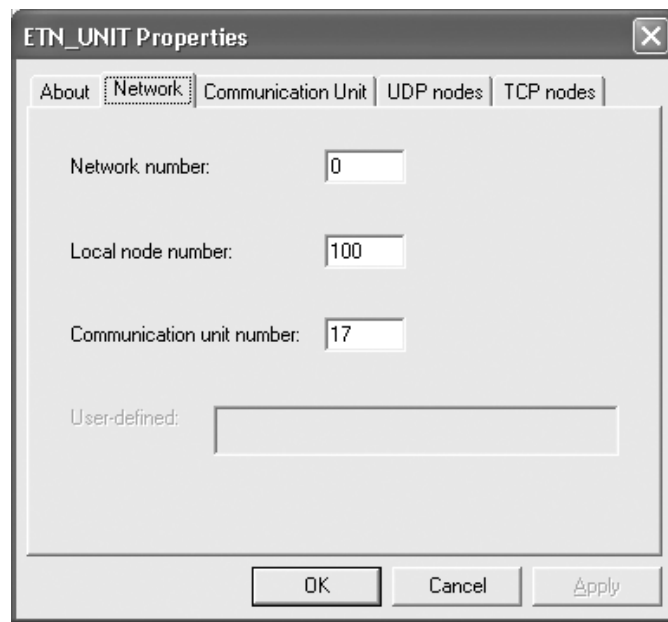

- Network number Set the network number for the personal computer (Ethernet port).
- Local node address Set the personal computer (Ethernet port) node address (1 to 254) on the Ethernet network.
- Communication unit number Set the unit number in decimal (16 to 31) for the personal computer (Ethernet port).

• Communication Unit Tab Page

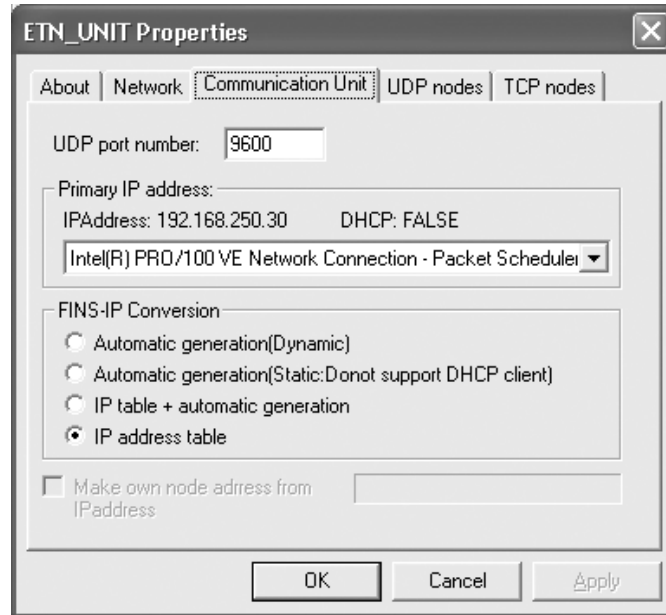

- UDP port number            Set the local UDP port number for the personal computer (Ethernet port). The default is 9600.
- Priority Network Card      If multiple Network Cards are mounted at the personal computer, select the Network Card that is to be given priority.
- FINS - IP address conversion    Set the IP address conversion method.
- UDP Nodes Tab Page: Automatic Generation Method (Dynamic or Passive)

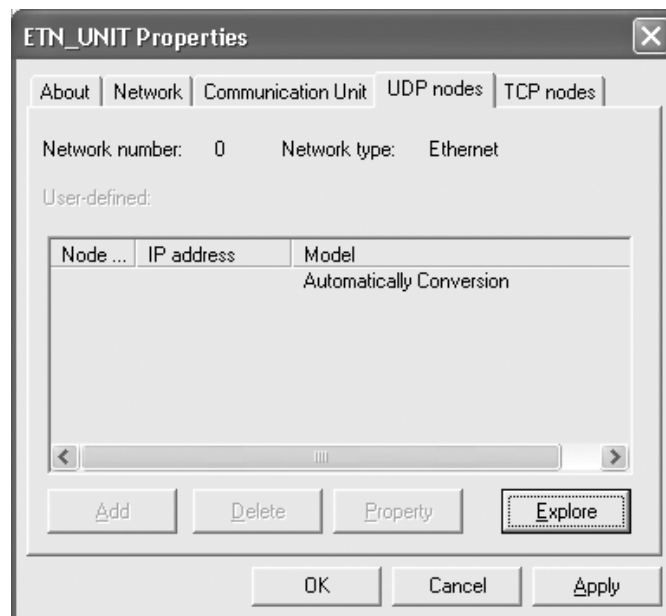

- UDP Nodes Tab Page: IP Address Table Method or Combined Method

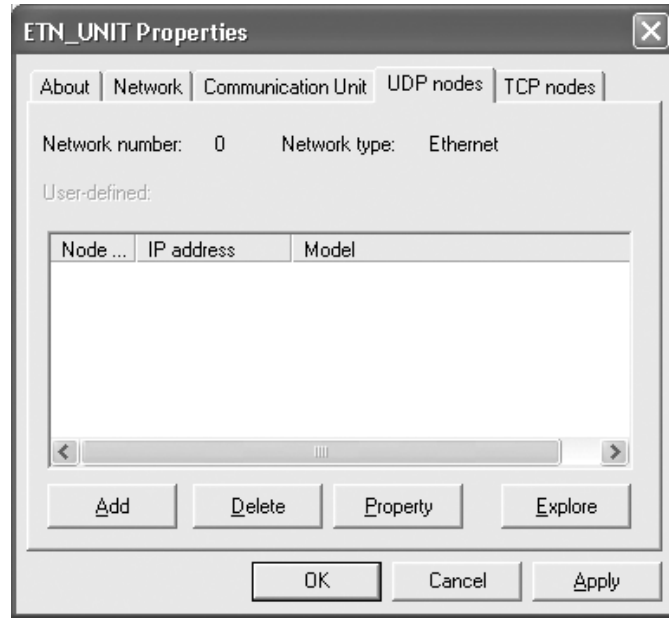

Click the **Add** Button, and then set the IP address table in the following Ethernet Node Definition Dialog Box.

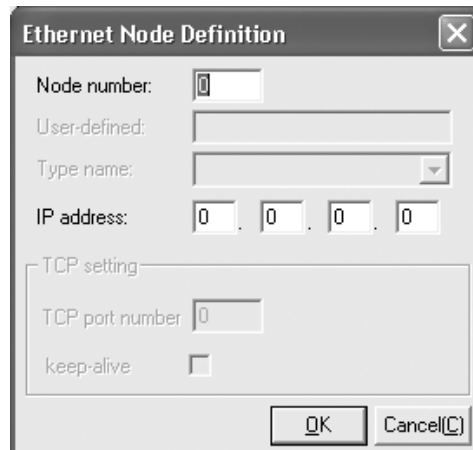

- Node address: Set the remote FINS node address.
- IP address: Set the remote IP address.

- TCP Nodes Tab Page

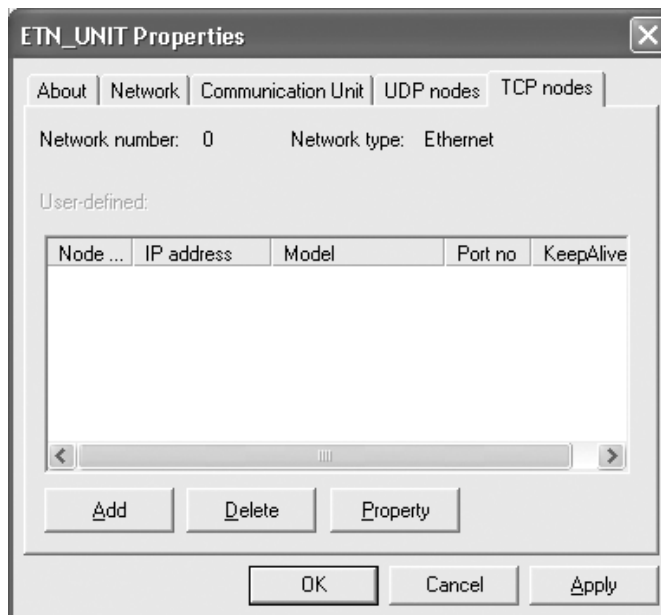

Click the **Add** Button, and then set the IP address table in the following Ethernet Node Definition Dialog Box.

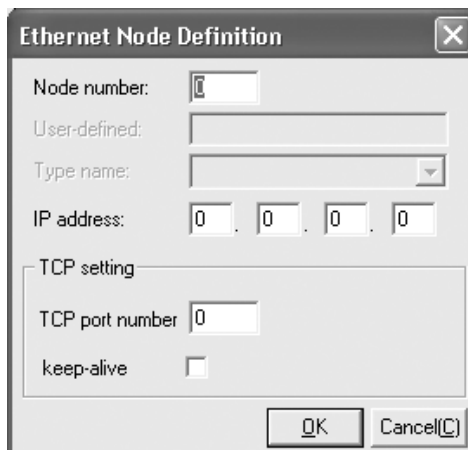

- Node address: Set the remote FINS node address.
- IP address: Set the remote IP address.
- Destination port number: Set the FINS/TCP port number for the remote node. Normally the PLC's default setting of 9600 should be specified.
- Keep-alive setting: Sets the keep-alive function. Normally this should be selected.

### **3. Starting FinsGateway ETN UNIT Service**

Select ETN\_UNIT from Services under the Basic Tab in the FinsGateway Setup Window, and then click the **Start** Button.



**System Configuration Example 3: Connecting the CX-Programmer Online Using the FINS/TCP Method**

In this example, an online connection is made by FINS/TCP to a PLC on an Ethernet network (PLC1 in the diagram below) from a CX-Programmer/CX-Integrator connected to the Ethernet network.

**Conditions**

- FINS/TCP method

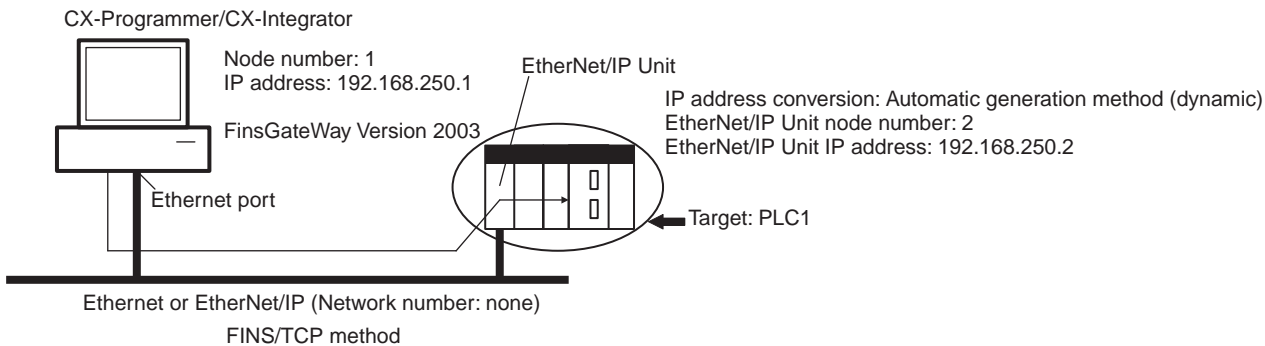

**CX-Programmer's Change PLC Dialog Box**

Settings for target PLC (PLC1)'s Change PLC Dialog Box			Setting
PLC name			PLC1
Network classification			FinsGateway
Network Tab Page	FINS destination	Network number	0
		Node address	2
	Frame length		2,000 bytes
	Response monitor time		2 seconds

**CX-Programmer's FINS/TCP Tab Page in Edit Parameters Dialog Box**

Item	Setting
FINS/TCP Port	Default (9600)
IP Router Table	None

Not set. (All defaults are used.)

**FinsGateway ETN UNIT Setup**

**TCP Nodes Tab Page: Ethernet Node Definition Dialog Box**

Item	Setting
Node address	2
IP address	192.168.250.2
Destination port number	9600
Keep-alive setting	Selected (yes)

## 8-6 Communicating between OMRON PLCs

FINS commands can be sent from the CPU Unit of a PLC by using the SEND(090), RECV(098), and CMND(490) instructions.

SEND(090): Writes I/O data from the local node to another node.

RECV(098): Reads I/O data from another node to the local node.

CMND(490): Issues FINS commands for controlling operations such as sending and receiving I/O memory data to and from other nodes, reading information regarding other nodes, and so on.

### 8-6-1 Communications Specifications

The following table shows the specifications for PLC communications using the SEND(090), RECV(098), and CMND(490) instructions.

Item	Specifications
Destination	1:1 SEND(090), RECV(098), CMND(490) instructions 1:N SEND(090), CMND(490) instructions (broadcasting)
Data length	SEND(090): 990 words (1,980 bytes) max.; broadcasting: 727 words (1,454 bytes) RECV(098): 990 words (1,980 bytes) max. CMND(490): 1,990 bytes max.; broadcasting: 1,462 bytes (after FINS command code)
Data contents	The following data is sent and received with the execution of each instruction. SEND(090): Sends request for remote node to receive data, and receives response data. RECV(098): Sends request for remote node to send data, and receives response data. CMND(490): Sends any FINS command and receives response data.
Communications port number	Ports 0 to 7 (Eight transmissions can occur simultaneously.)
Response monitor time	0000: 2 s (default) 0001 to FFFF: 0.1 to 6,553.5 s in 0.1-s increments (specified by user)
Number of retries	0 to 15 retries

- Note**
1. The maximum data length is limited to 512 bytes for data exchange between the PLC and SYSMAC LINK Systems or the PLC and SYSMAC BUS/2 Remote I/O Systems.
  2. When broadcasting, do not require a response.  
Use the FINS/UDP method for broadcasting.

## 8-6-2 PLC Communications Data Areas

The following table shows the I/O data areas involved when SEND(090) and RECV(098) are used.

Area	Range
CIO Area	CIO 0000 to CIO 6143
Work Area	W000 to W511
Holding Area	H000 to H1535
Auxiliary Area	A000 to A959 (See note 1.)
Timer Area	TIM0000 to 4095
Counter Area	CNT0000 to 4095
DM Area	D00000 to D32767
EM Area	E00000 to E32767 (See note 2.)

- Note**
1. Data cannot be written to words A000 to A447 in the Auxiliary Area.
  2. A maximum of 13 banks in the EM Area can be used for a CS1/CJ1 CPU Unit. A maximum of 25 banks in the EM Area can be used for a CJ2H CPU Unit. A maximum of 4 banks in the EM Area can be used for a CJ2M CPU Unit. For details regarding the EM Area, refer to the operation manual for the PLC that is used. Refer to the operation manual for your CPU Unit to confirm EM Area support.

### 8-6-3 Using SEND(090), RECV(098), and CMND(490)

Make the settings shown below when using the SEND(090), RECV(098), and CMND(490) instructions in the user's ladder-diagram program in the PC.

#### SEND(090)

The SEND(090) instruction sends the data in n number of words, starting from the beginning word S at the local node, to the words starting from the beginning word D at the remote destination node (node address N).

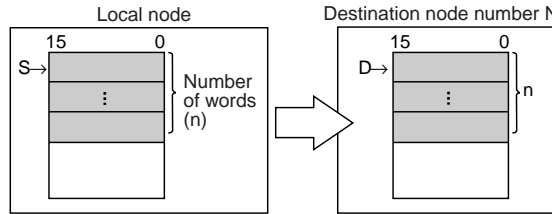

(@)SEND(90)
S
D
C

S: Local node beginning word  
 D: Destination beginning word  
 C: First word of control data (below)

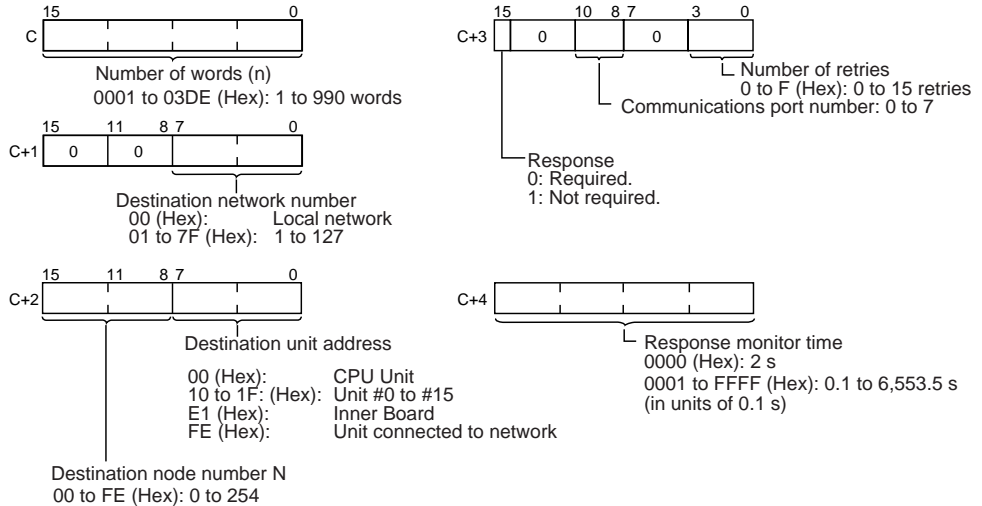

Destination node number N  
 00 to FE (Hex): 0 to 254  
 The same data can be broadcast to all nodes on the network by setting the destination node number to FF (Hex).

The range of node addresses is different for networks other than Ethernet.

**Note** The message service does not guarantee that a message will reach the destination node. A message may be lost during transmission due to factors such as noise. To prevent this from occurring when using message services, it is common to set up retry processing at the node from which instructions are issued. With the SEND(090), RECV(098), and CMND(490) instructions, retry processing is executed automatically by specifying the number of retries, so specify a number other than 0.

RECV(098)

With the RECV(098) instruction, the data in m number of words, starting from the beginning word S at the remote node (node address M) is received at the words starting from the beginning word D at the local node.

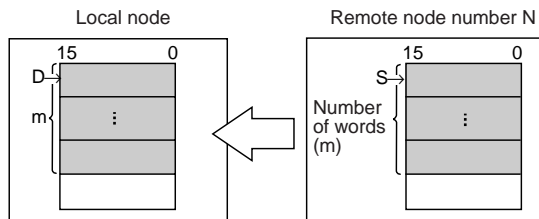

(@)RECV(98)
S
D
C

S: Remote node beginning word  
 D: Local beginning word  
 C: First word of control data (below)

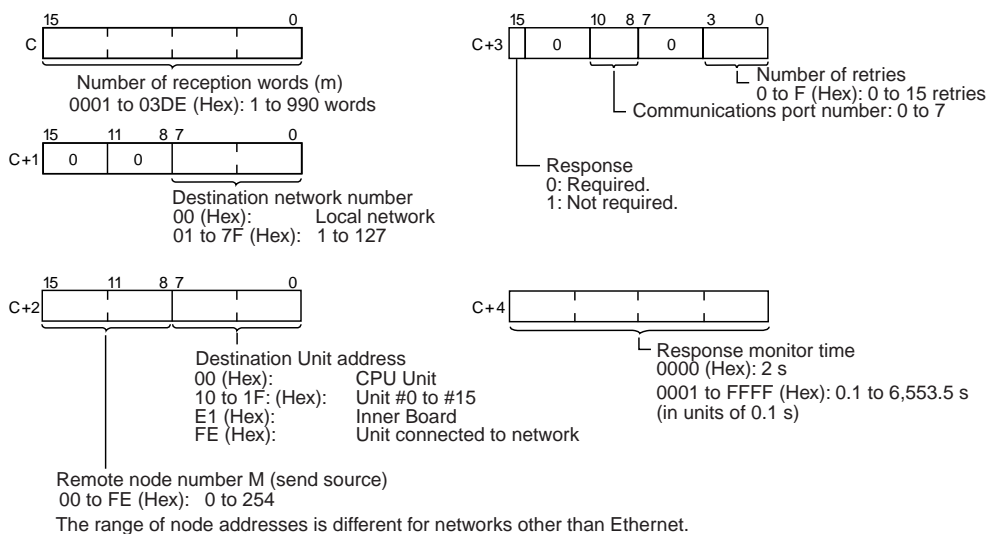

**Note** The message services function does not guarantee that a message will reach the destination node. A message may be lost during transmission due to factors such as noise. In order to prevent this from occurring when using message services, it is common to set up retry processing at the node from which instructions are issued. With the SEND(090), RECV(098), and CMND(490) instructions, retry processing is executed automatically by specifying the number of retries, so specify a number other than 0.

CMND(490)

The CMND(490) instruction sends n bytes of command data, starting from the beginning word S at the local node, to the node at node address N. The data in m number of words, starting from the beginning word S at the remote node (node address M) is received at the words starting from the beginning word D at the local node.

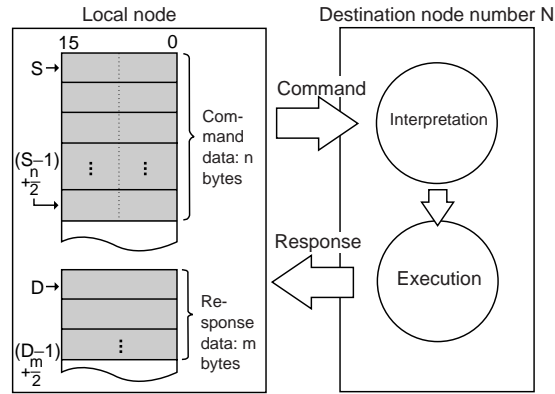

(@)CMND(490)	
S	S: Beginning command storage word
D	D: Beginning response storage word
C	C: First word of control data (below)

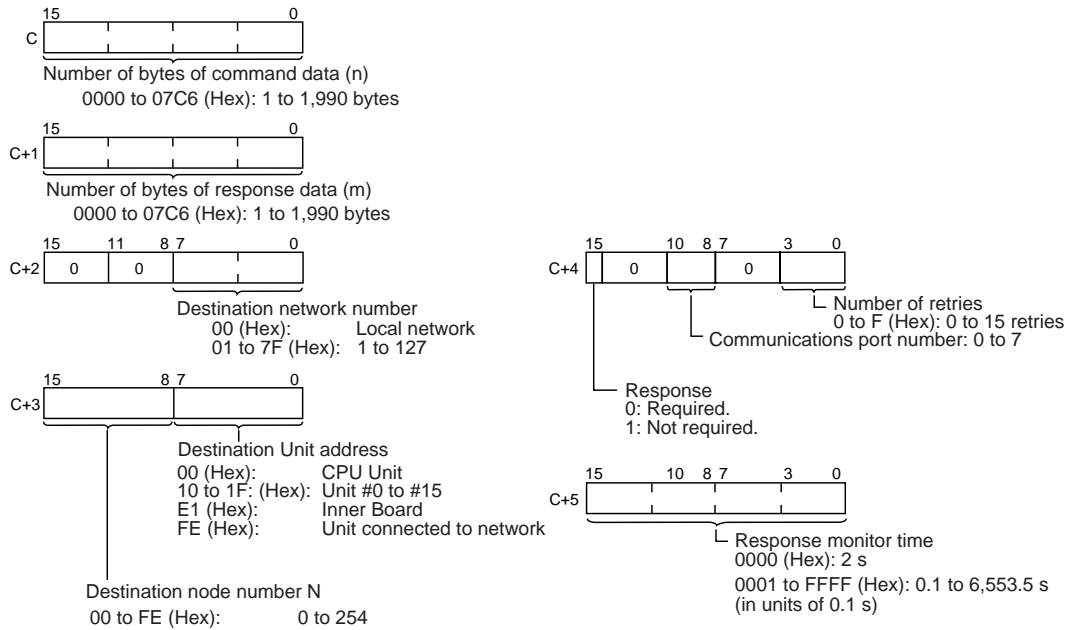

The same data can be broadcast to all nodes on the network by setting the destination node number to FF (Hex).  
The range of node addresses is different for networks other than Ethernet.

**Note** The message services function does not guarantee that a message will reach the destination node. A message may be lost during transmission due to factors such as noise. In order to prevent this from occurring when using message services, it is common to set up retry processing at the node from which instructions are issued. With the SEND(090), RECV(098), and CMND(490) instructions, retry processing is executed automatically by specifying the number of retries, so specify a number other than 0.

**Commands Addressed to CS/CJ-series CPU Units**

The following table provides a list of FINS commands that can be processed by a CS/CJ-series CPU Unit. For details, refer to the *CS/CJ-series Programmable Controllers Communications Commands Reference Manual (W342)*.

For details on FINS commands that can be processed by the EtherNet/IP Unit or built-in EtherNet/IP port, refer to *Appendix E FINS Commands Addressed to EtherNet/IP Units or Built-in EtherNet/IP Ports*.

Usage	Command code		Name	Function
	MR	SR		
I/O memory area access	01	01	MEMORY AREA READ	Reads the contents of consecutive I/O memory area words.
	01	02	MEMORY AREA WRITE	Writes the contents of consecutive I/O memory area words.
	01	03	MEMORY AREA FILL	Writes the same data to the specified range of I/O memory area words.
	01	04	MULTIPLE MEMORY AREA READ	Reads the contents of specified non-consecutive I/O memory area words.
	01	05	MEMORY AREA TRANSFER	Copies the contents of consecutive I/O memory area words to another I/O memory area.
Parameter access (registered I/O tables, routing tables, etc.)	02	01	PARAMETER AREA READ	Reads the contents of consecutive parameter area words.
	02	02	PARAMETER AREA WRITE	Writes the contents of consecutive parameter area words.
	02	03	PARAMETER AREA FILL (CLEAR)	Writes the same data to the specified range of parameter area words.
Program area access	03	06	PROGRAM AREA READ	Reads the UM (User Memory) area.
	03	07	PROGRAM AREA WRITE	Writes to the UM (User Memory) area.
	03	08	PROGRAM AREA CLEAR	Clears the UM (User Memory) area.
Operating mode changes	04	01	RUN	Changes the CPU Unit's operating mode to RUN or MONITOR.
	04	02	STOP	Changes the CPU Unit's operating mode to PROGRAM.
Machine configuration reading	05	01	CPU UNIT DATA READ	Reads CPU Unit data.
	05	02	CONNECTION DATA READ	Reads the model numbers of the device corresponding to addresses.
Status reading	06	01	CPU UNIT STATUS READ	Reads the status of the CPU Unit.
	06	20	CYCLE TIME READ	Reads the maximum, minimum, and average cycle time.
Time data access	07	01	CLOCK READ	Reads the present year, month, date, minute, second, and day of the week.
	07	02	CLOCK WRITE	Changes the present year, month, date, minute, second, or day of the week.
Message display	09	20	MESSAGE READ/CLEAR	Reads and clears messages, and reads FAL/FALS messages.
Access rights	0C	01	ACCESS RIGHT ACQUIRE	Acquires the access right as long as no other device holds it.
	0C	02	ACCESS RIGHT FORCED ACQUIRE	Acquires the access right even if another device already holds it.
	0C	03	ACCESS RIGHT RELEASE	Releases the access right that has been acquired.
Error log	21	01	ERROR CLEAR	Clears errors or error messages.
	21	02	ERROR LOG READ	Reads the error log.
	21	03	ERROR LOG POINTER CLEAR	Clears the error log pointer.

Usage	Command code		Name	Function
	MR	SR		
File memory	22	01	FILE NAME READ	Reads file memory data.
	22	02	SINGLE FILE READ	Reads a specified length of file data from a specified position within a single file.
	22	03	SINGLE FILE WRITE	Writes a specified length of file data from a specified position within a single file.
	22	04	FILE MEMORY FORMAT	Formats (initializes) the file memory.
	22	05	FILE DELETE	Deletes specified files stored in the file memory.
	22	07	FILE COPY	Copies files from one file memory to another file memory in the same system.
	22	08	FILE NAME CHANGE	Changes a file name.
	22	0A	MEMORY AREA-FILE TRANSFER	Transfers or compares data between the I/O memory area and the file memory.
	22	0B	PARAMETER AREA-FILE TRANSFER	Transfers or compares data between the parameter area and the file memory.
	22	0C	PROGRAM AREA-FILE TRANSFER	Transfers or compares data between the UM (User Memory) area and the file memory.
	22	15	CREATE/DELETE DIRECTORY	Creates or deletes a directory.
Debugging	23	01	FORCED SET/RESET	Force-sets or force-resets bits, or releases force-set status.
	23	02	FORCED SET/RESET CANCEL	Cancels all bits that have been force-set or force-reset.

### 8-6-4 Writing Programs

Programs incorporating the SEND(090), RECV(098), and CMND(490) instructions are generally created using the Communications Port Enabled Flag and the Communications Port Error Flag as input conditions. CS/CJ-series CPU Units have eight communications ports. Only one instruction can be executed at any given port at one time, however, so the program must not overlap the use of any of the ports. A program example is provided below.

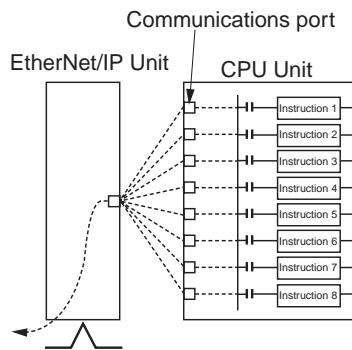

There are eight communications ports, so up to eight communications instructions can be executed at a time. The number of messages that can be sent or received with a single CPU Bus Unit service, though, is not more than two each for the CPU Unit to the EtherNet/IP Unit and for the EtherNet/IP Unit to the CPU Unit.



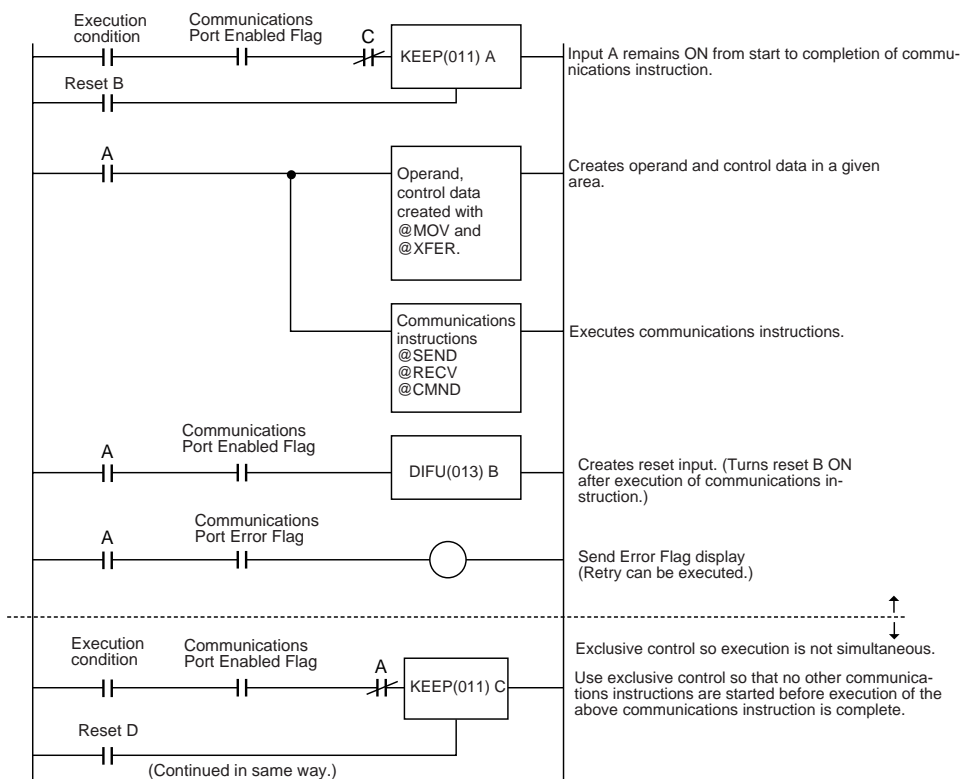

The execution status of the SEND(090), RECV(098), and CMND(490) instructions is always reflected by the communications flags (i.e., the Communications Port Enabled Flag and the Communications Port Error Flag). The CS/CJ-series CPU Unit's communications flags are allocated in the Auxiliary Area as shown in the following table.

Flag name	Address		Contents
	Word	Bits	
Communications Port Enabled Flag	A202	Bit 7: Port 7 Bit 6: Port 6 Bit 5: Port 5 Bit 4: Port 4 Bit 3: Port 3 Bit 2: Port 2 Bit 1: Port 1 Bit 0: Port 0	OFF: Execution enabled (being executed) ON: Execution disabled (not being executed)
Communications Port Error Flag	A219	Bit 7: Port 7 Bit 6: Port 6 Bit 5: Port 5 Bit 4: Port 4 Bit 3: Port 3 Bit 2: Port 2 Bit 1: Port 1 Bit 0: Port 0	0: Normal completion 1: Abnormal completion

**Note** In CS/CJ-series PLCs, communications ports 0 to 7 are also used when executing the PCMR(260) (PROTOCOL MACRO), TXDU(256), and RXDU(255) instructions, so these flags are shared by SEND(090), RECV(098), CMND(490), PCMR(260), TXDU(256), and RXDU(255). SEND(090), RECV(098), and CMND(490) cannot be executed at a communications port if PCMR(260) TXDU(256), or RXDU(255) is being executed at that port.

### Communications Port Completion Codes

The status of a SEND(090), RECV(098), and CMND(490) instruction after execution is reflected as a communications port completion code, in one word (two bytes) of data as shown in the following table. (The value is 0000 during instruction execution.) The recorded status is saved until execution of the next instruction.

Word	Contents
A203	Communications Port 0 Completion Code
A204	Communications Port 1 Completion Code
A205	Communications Port 2 Completion Code
A206	Communications Port 3 Completion Code
A207	Communications Port 4 Completion Code
A208	Communications Port 5 Completion Code
A209	Communications Port 6 Completion Code
A210	Communications Port 7 Completion Code

The meanings of the communications port completion codes are the same as those for FINS commands and responses. Bits 08 to 15 in the communications port completion code correspond to the first byte of the response code, and bits 00 to 07 correspond to the second byte. For details, refer to *14-6 Troubleshooting with FINS Response Codes*.

### Communications Port Error Flag and Completion Codes CMND(490)

Errors that occur when CMND(490) is used generate a Communications Port Error Flag and are recorded in a communications port completion code only in the following cases:

- When a response timeout error has occurred.
- When the number of communications data bytes exceeds the maximum value for the Unit (i.e., 2,000 bytes for the EtherNet/IP Unit or built-in EtherNet/IP port).
- When the actual number of response bytes is greater than the number of reception bytes that has been set. (The response is not stored in this case.)

Errors other than these are recorded in the response codes of the responses stored from the beginning response storage word onwards. Be careful of these, because there are no Communications Port Error Flags and they are not recorded in a communications port completion code.

### Timing of Communications Flag Changes

- The Communications Port Enabled Flag remains OFF during communications and turns ON when they are completed (regardless of whether or not an error occurs).
- The Communications Port Error Flag retains its status until the next transmission or reception.
- The Communications Port Error Flag turns OFF with the execution of the next communications instruction even if there was an abnormal completion.

Example

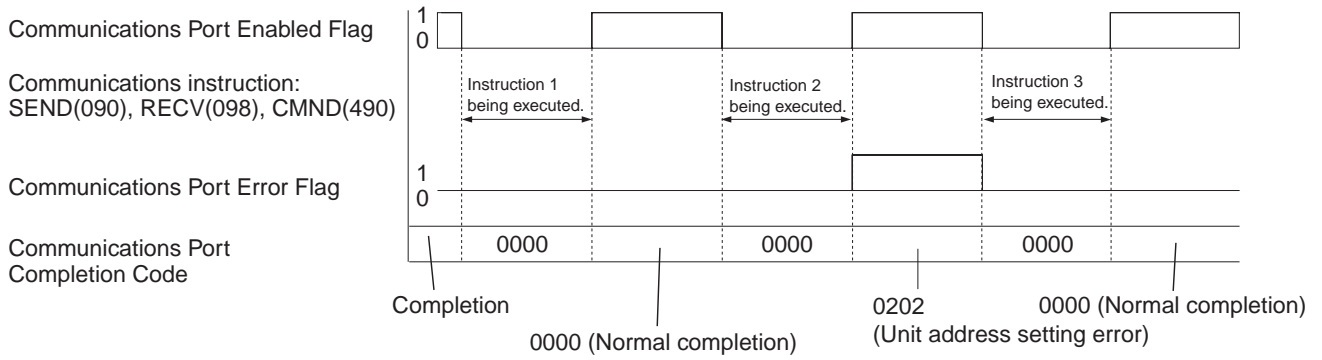

### 8-6-5 Program Example

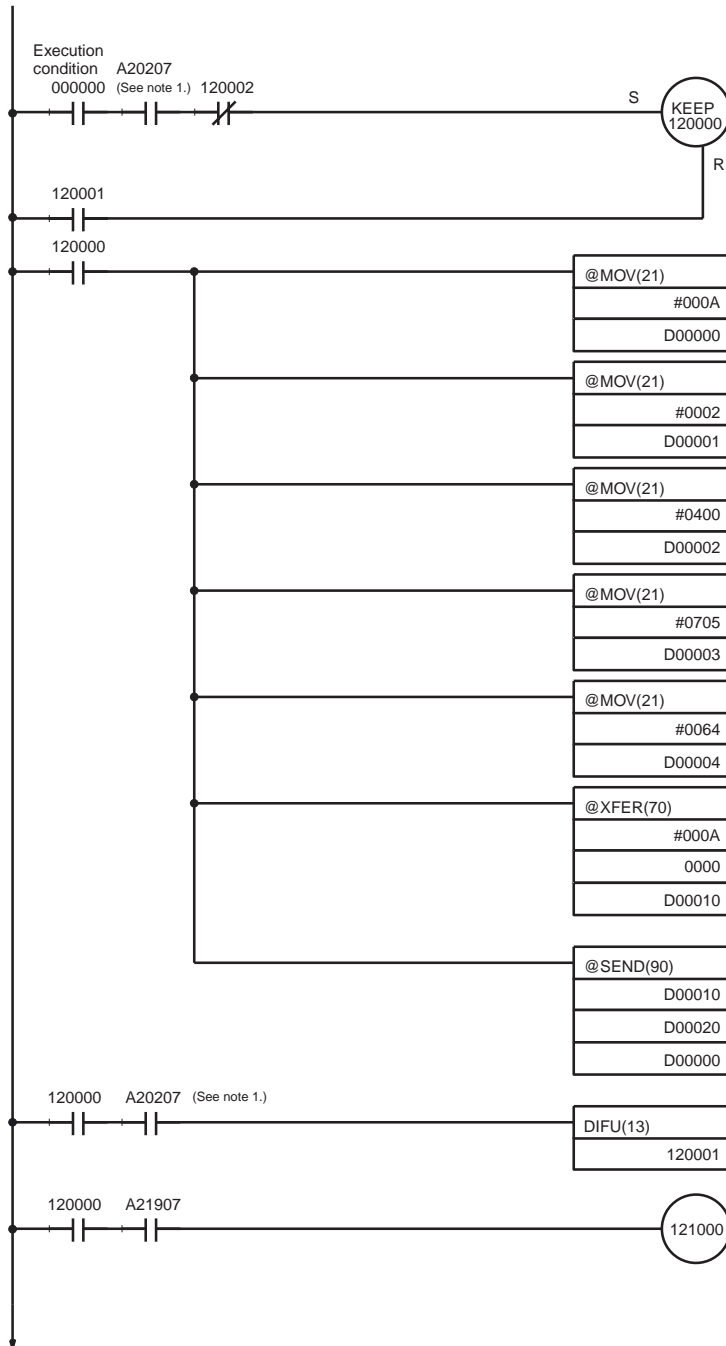

When the Communications Port Enabled Flag for port 7 is ON, and RECV(098) is not being executed, the send execution program will start when execution condition CIO 000000 turns ON.

Input CIO 120000 remains ON from the start of SEND(090) execution until completion.

Control Data Creation

Word	Contents	Meaning
D0000	00 0A	Number of send words = 10
D0001	00 02	Destination network number = 2
D0002	04 00	Destination node number = 4 Destination unit address = 0
D0003	07 05	Response required. Communications port No. used = 7 Number of retries = 5
D0004	00 64	Response monitor time = 10 s

Send Data Creation

Ten words of data from word CIO 0000 is stored from D00010 onwards.

Ten words of data from D00010 at the local node is sent to D00020 onwards at network number 2, node number 4, unit address 0 (the PLC).

Reset Input Creation

Send Error Display

(Continued on next page.)

(Continued from previous page.)

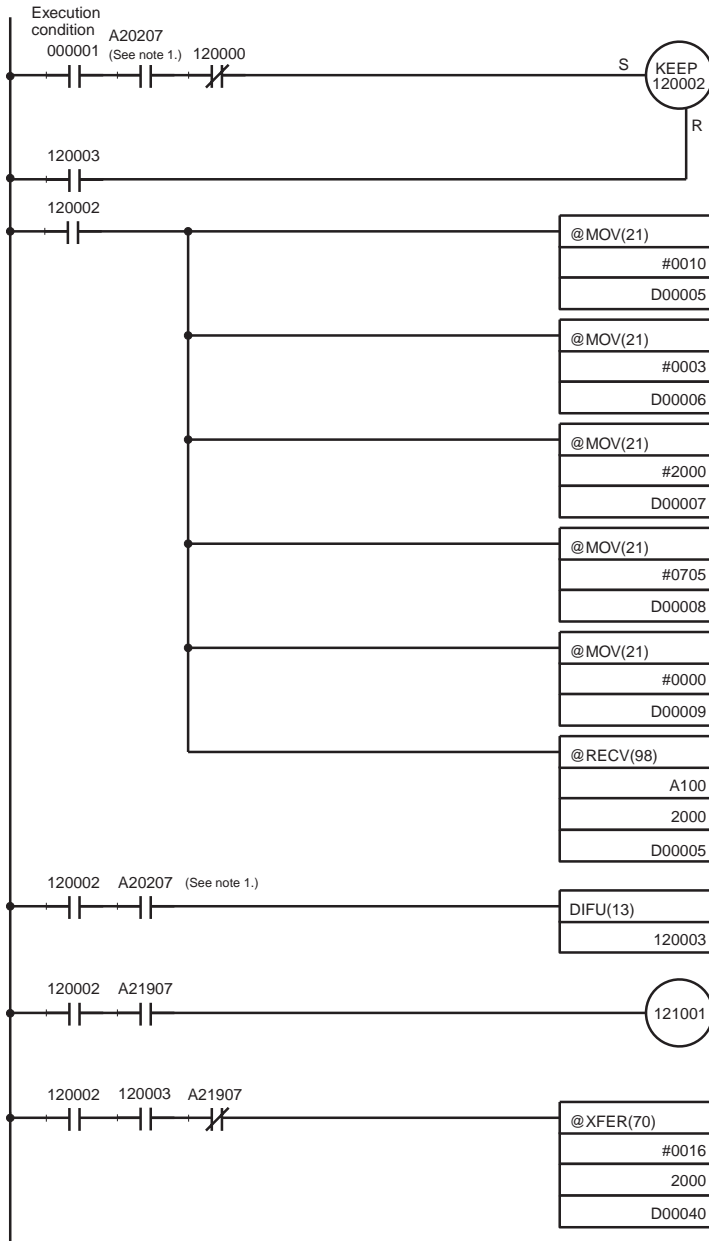

When the Communications Port Enabled Flag for port 7 is ON, and SEND(090) is not being executed, the transmission execution program will start when execution condition CIO 000001 turns ON.

Input CIO 120002 remains ON from the start of RECV(098) execution until completion.

Control Data Creation

Word	Contents	Meaning
D0005	00 10	Number of reception words = 16
D0006	00 03	Source network number = 3
D0007	20 00	Source node number = 32 Source unit address = 0
D0008	07 05	Response required. Communications port No. used = 7 Number of retries = 5
D0009	00 00	Response monitor time = Default

A total of 16 words of data beginning from word A100 at network number 3, node number 32, unit address 0 (the PLC) is received at word CIO 2000 onwards of the local node.

Reset Input Creation

Reception Error Display

Reception Data Processing

If there is no reception processing completion error, the 16 words of data received from word CIO 2000 onwards is stored at D00040 onwards.

- Note**
1. With CS/CJ-series PLCs, the Communications Port Enabled Flags at bits 0 to 7 in word A202 turn OFF even when the PCMR(260) instruction is being executed using the ports corresponding to those flags.
  2. Before using the sample program as is, confirm that the memory areas (words and bits) used in the sample program are not already being used in the user program or by Special I/O Units.

## 8-7 Precautions on High Traffic in FINS Communications

When applications are constructed using FINS communications services, communications errors (from multiple response timeouts) may occasionally occur due to high traffic, depending on the system configuration and the application programs. This section describes precautions for systems with high traffic in FINS communications.

### ■ Conditions for High Traffic

A heavy communications load may occur at an EtherNet/IP Unit or built-in EtherNet/IP port if FINS messages and CIP messages from multiple nodes are concentrated on that EtherNet/IP Unit or built-in EtherNet/IP port. The EtherNet/IP Unit or built-in EtherNet/IP port and the CPU Unit may have insufficient processing capacity for the volume of FINS messages (commands) that are coming from the network.

For example, suppose that approximately 20 ms are required to process a single FINS frame (i.e., 20 ms from the time that the command is received at the EtherNet/IP Unit or built-in EtherNet/IP port until a response is sent). If 100 or more FINS frames (commands) are received at once from multiple communicating nodes, it will take approximately 2 seconds to send a response to the last command. If a timeout is set at the remote node for 2 seconds or less, then a timeout will be generated. A retry will begin due to the timeout, and the traffic to the EtherNet/IP Unit or built-in EtherNet/IP port will thus be increased even further, until ultimately the responses to all the nodes will be too slow. At this point, the system is overloaded.

### ■ Avoiding Errors due to High Traffic

To avoid high traffic from FINS communications, the communications load must be kept down to a reasonable level. To accomplish this, follow the procedure below.

1. Specify the node where FINS frames seem to be concentrated.
2. Estimate the total processing time for all of the FINS frames processed at that node. (For details, refer to *10-5-1 Maximum Transmission Delays (Excluding Delays in the Network)*.)
3. Set the timeout value for all of the SEND(090), RECV(098), and CMND(490) FINS commands at all the remote nodes to at least 1.5 times the total processing time for all of the FINS frames.
4. As much as possible, implement communications traffic testing up to the point of actual system operation. If any problem occurs, adjust the traffic.
5. If a commercially-available protocol analyzer can be used, then the actual FINS frame processing time (i.e., the time from when a command is received at the EtherNet/IP Unit or built-in EtherNet/IP port until a response is sent) can be measured under high traffic conditions and the communications traffic can be further adjusted as required.

# SECTION 9

## Message Communications

This section describes message communications using FINS commands sent from the ladder program in the CPU Unit of the PLC.

9-1	Sending Explicit Messages . . . . .	236
9-1-1	Sending Explicit Messages Using CMND(490). . . . .	244
9-2	Receiving Explicit Messages . . . . .	249
9-2-1	List of PLC Object Services . . . . .	250

## 9-1 Sending Explicit Messages

CS/CJ-series EtherNet/IP Units and built-in EtherNet/IP ports can send explicit messages. Only CIP unconnected message (UCMM) communications can be used to send explicit messages. Explicit messages can be sent to the following destinations.

- EtherNet/IP Units made by other manufacturers
- Other PLCs with a CS/CJ-series EtherNet/IP Unit or built-in EtherNet/IP port

### Example

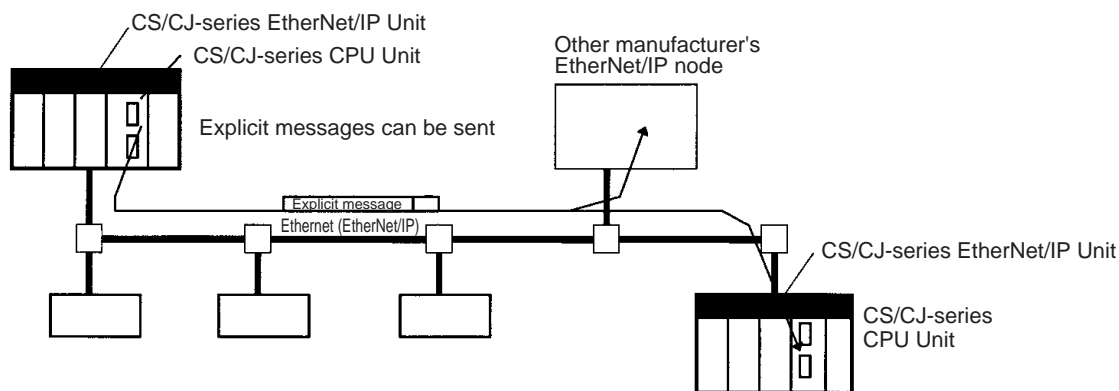

When the destination is another company's EtherNet/IP node, an explicit message can be sent to the EtherNet/IP Unit or built-in EtherNet/IP port using FINS command code 28 01 or 28 10, through the Connection Manager class's Unconnected Send service, as shown in the following diagram.

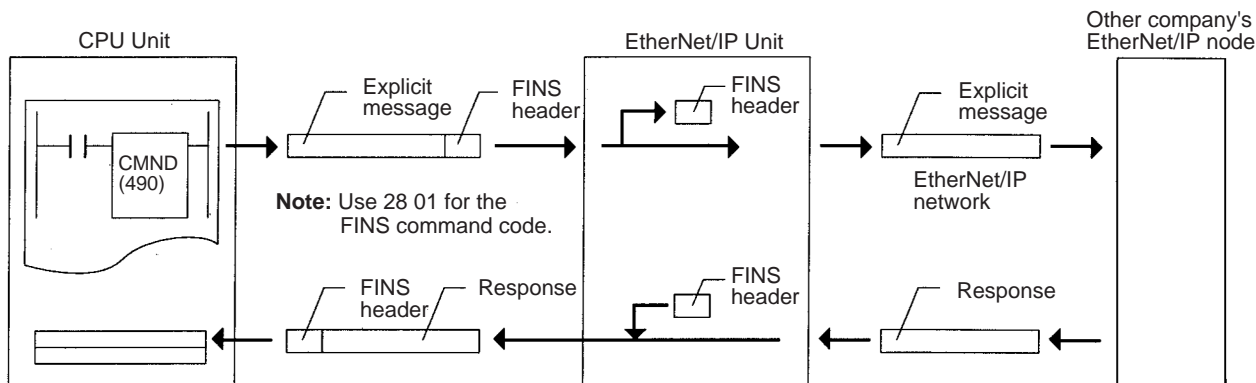

When sending an explicit message, set the local node's EtherNet/IP Unit or built-in EtherNet/IP port as the destination of the FINS command, and not the actual destination (other company's EtherNet/IP node). Specify the node address of the actual destination in the command data of the explicit message send command.

There are two ways to send an explicit message send command:

- 1,2,3... 1. CIP UCMM MESSAGE SEND command (28 10)  
Messages can be routed through multiple CIP network layers. (Messages can be routed through 16 network levels. The explicit message send command may time out if routing is attempted for more than 16 networks.)
2. EXPLICIT MESSAGE SEND command for DeviceNet Units (28 01)  
This command is compatible with the DeviceNet Unit's explicit message send command (28 01) in the ladder program. The message must be sent



in the same network layer and the remote node's IP address range is limited.

The following diagram shows an example of actual node address specifications.

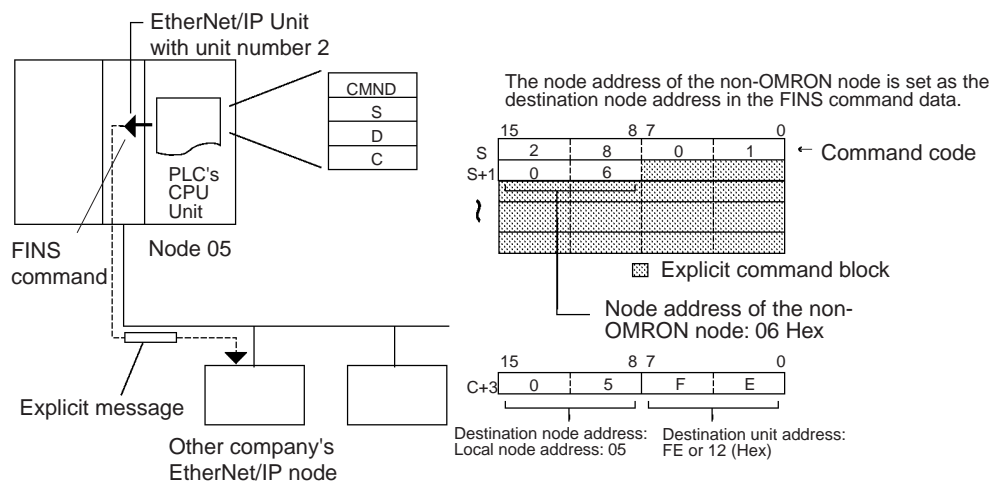

**Note** Depending on conditions, the destination slave may not always accept an explicit message. Always perform retry processing when sending explicit messages.

### CIP UCMM MESSAGE SEND (28 10)

This command sends an explicit message for CIP routing to another node's specified class and receives a response. There are two command formats: one with a specified route path (path to the target device), and the other without the route path.

#### Command Block

- Relay Hop Format

The following format includes the route path (routing service data). Specify the entire routing path in the command's request path.

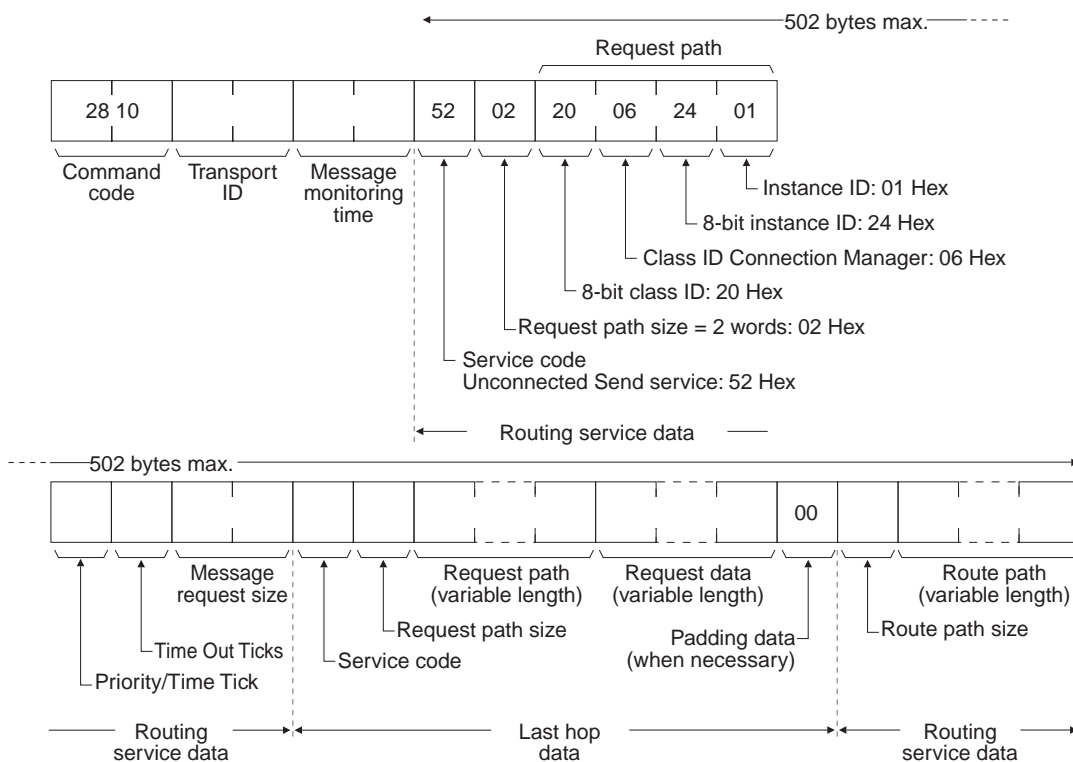

- Last Hop Format

The following format does not include the route path.

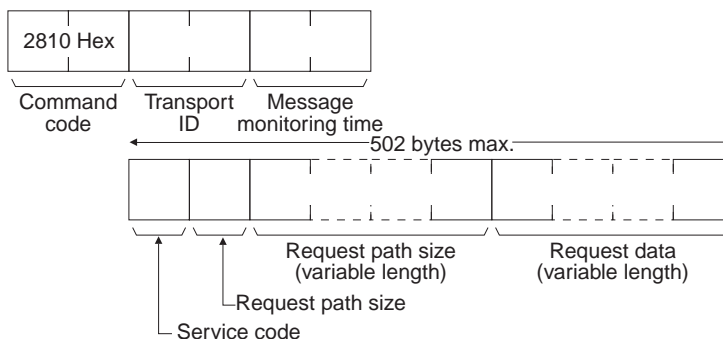

Response Block

The following normal response is returned to a transmitted CIP UCMM MESSAGE SEND command if it was completed normally.

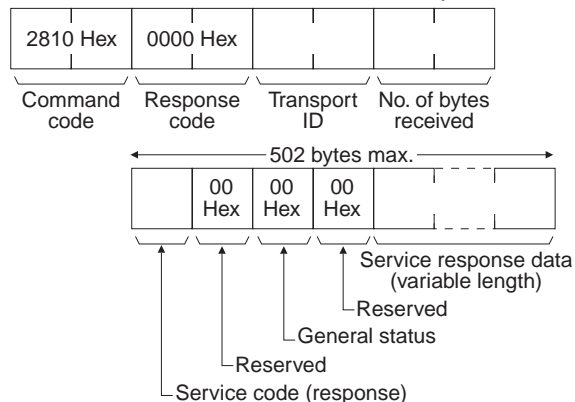

The following response is returned if an error occurs in a transmitted CIP UCMM MESSAGE SEND command.

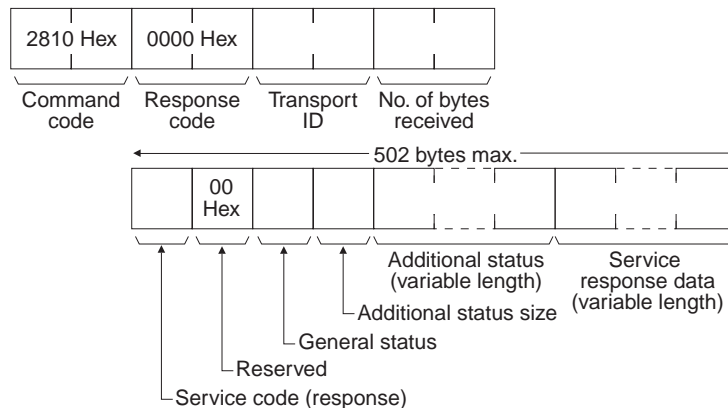

The following response is returned if the CIP UCMM MESSAGE SEND command could not be sent or timed out.

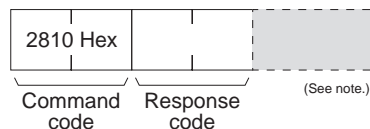

**Note:** There may be additional data depending on the response code, e.g., for a relay error.

Parameters

**Transport ID (command, response):**

When multiple CIP UCMM MESSAGE SEND commands are being sent, the Transport ID identifies the commands. This Transport ID is returned unchanged in the response.

**Message monitoring time (command):**

Specifies the monitoring time in 10-ms units, in order to monitor the time from the point that the EtherNet/IP Unit or built-in EtherNet/IP port extracts the CIP explicit message from this command until a response is received. The monitoring time can be set between 0.01 and 655.35 s.

**Service code (command, response):**

In the command, this code is the service code defined for EtherNet/IP. In the response, bit 15 of the service code specified in the command is turned ON and the resulting value is returned.

In the routing format for relay hops, the first service code (in the routing service data) is 52 Hex, which is the Unconnected Send service.

**Request path size (command):**

Specifies the number of words of data that are specified in the request path field.

In the routing format for relay hops, the first request path size (in the routing service data) is 02 Hex.

**Request path (command):**

Specifies the request path (class ID, instance ID, etc.) in bytes. If there is an odd number of bytes, pad the last byte with a 0 so that the data is in full word units.

In the routing format for relay hops, the first request path (in the routing service data) is 20 06 24 01 Hex (Connection Manager). For details, refer to the description of the *Route Path* in *Appendix D CIP Message Communications*.

**Request data (command):**

In the command, specify the data determined by the service code.

In the response, the reception data determined by the service code will be returned.

**Priority/Time tick (command):**

The timeout time specified by the Priority Time Tick is used as a base value to specify the actual timeout value. For details, refer to the description of the *Priority/Time Ticks and Time Out Ticks* at the end of *Appendix D CIP Message Communications*.

**Time Out Ticks (command):**

Specifies the base value of the timeout time. For details, refer to the description of the *Priority/Time Ticks and Time Out Ticks* at the end of *Appendix D CIP Message Communications*.

**Message request size (command):**

Specifies the number of bytes of data from the second service code to the request data. The data size is specified in LSB, MSB order.

For example, if there are 400 bytes, the data size is 0190 hex bytes, which is entered as 90 01 hex.

**Padding data (command):**

If the message request size specifies an odd number of bytes, use 00 hex as padding in the last byte. The padding data is not required if there is an even number of bytes.

**Route path size (command):**

Specifies the number of words of data that are specified in the route path field.

**Route path (command):**

Specifies the path (route path) to the target device. For details, refer to the description of the *Route Path* in *Appendix D CIP Message Communications*.

**No. of bytes received (response):**

This hexadecimal value is returned to indicate the number of bytes of data received after the service code (response).

**General status (response):**

The general status defined in EtherNet/IP is returned. The normal response is 00 hex. For details, refer to the description of the *Response Codes* in *Appendix D CIP Message Communications*.

**Additional status size (response):**

This hexadecimal value is returned to indicate the number of words of data in the additional status field.

**Additional status (response):**

The additional status defined in EtherNet/IP is returned. For details, refer to the description of the *Response Codes* in *Appendix D CIP Message Communications*.

**Service response data (response):**

The reception data determined by the service code is returned.

**Description**

- The CIP UCMM MESSAGE SEND command is used to send an EtherNet/IP-defined explicit message to another company's node and receive a response.
- Unlike other FINS commands, the destination of a CIP UCMM MESSAGE SEND command's control data is the local node's EtherNet/IP Unit or built-in EtherNet/IP port, and the actual destination node is specified in the command's route path.
- When an EtherNet/IP Unit or built-in EtherNet/IP port receives an explicit message, it automatically returns a response to the message.
- When specifying the timeout time, the proper values are different for last-hop and relay-hop methods. With the last-hop method, set the timeout time for the actual request service processing. With the relay-hop method, the timeout for the relay path must be added to the timeout time for the actual request service processing.

In CIP routing, the node/Unit performing the routing subtracts the timeout time for 1 hop, deletes its own address from the routing information, and relays the message to the next node/Unit.

Set the following timeout values for command processing.

The maximum number of relay nodes (Units) is 16. If the number is more than 16, the explicit message send command may time out even if the conditions of network and each node (Unit) are normal. If more than 16 relay nodes (Units) have been set, a constant time must be specified for the request service processing timeout time (normally 0000 hex).

- Priority Time Tick and Time Out Ticks =  $(5 \text{ s} \times \text{Number of relay nodes/Units}) + \text{Request processing timeout}$
- Message monitoring time  $\geq$  Priority Time Tick and Time Out Ticks
- CMND(490) timeout set value = Message monitoring time

A timeout may occur sooner than the actual set value, depending on the point where the timeout occurs in the path.

- General status = 01 hex, and Additional status = 0204 hex

A FINS timeout error response (0205 hex) may occur if the CMND(490) timeout set value or message monitoring time is less than the Priority Time Tick and Time Out Ticks.

- Note**
1. For details on the parameters of explicit messages, refer to the EtherNet/IP and CIP specifications.
  2. Acquire EtherNet/IP and CIP specifications from the ODVA.

Website: <http://www.odva.org/>

**EXPLICIT MESSAGE SEND (28 01)**

EXPLICIT MESSAGE SEND will send a DeviceNet Unit-compatible explicit message to the specified class of another node and receive a response.

The other node is specified with the destination node address in the command. The actual destination IP address is as follows.

$$\text{Destination IP address} = (\text{Local IP address \& Subnet mask}) + \text{Destination node address}$$

**Command Block**

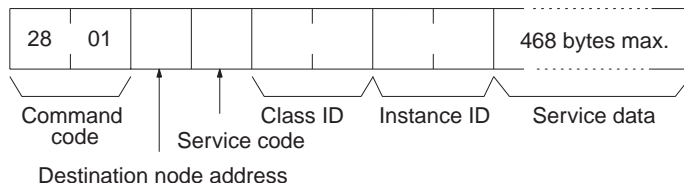

**Response Block**

**Normal Response**

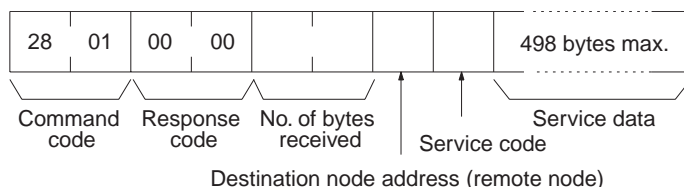

**Error Responses**

The following response is returned if an error occurs for the explicit message.

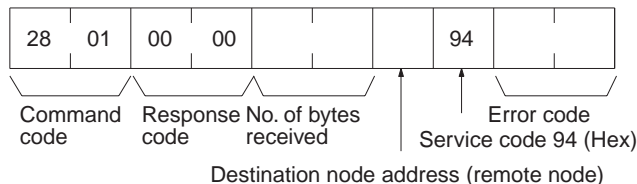

The following response is returned if the explicit message cannot be sent or times out.

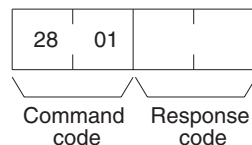

**Parameters**

**Destination node address (command):**

The node address of the destination of the explicit message.

The node address of the local EtherNet/IP Unit or built-in EtherNet/IP port is specified in the control data for the CMND(490), but the node address of the actual destination is specified here in the FINS command. The destination node address cannot be set to 00 hex or FF hex.

**Service code (command, response):**

A service code defined for EtherNet/IP. In a normal response, bit 15 of the service code specified in the command will be turned ON and returned. In an error response, 94 Hex will always be returned.

**Class ID (command):**

The class ID of the destination of the explicit message.

**Instance ID (command):**

The instance ID of the destination of the explicit message.

**Service data (command, response):**

The data defined for the services codes.

**No. of bytes received (response):**

The number of bytes received from the destination node address (remote node).

**Destination node address (remote node):**

The node address of the OMRON Special I/O Slave Unit or Slave manufactured by another company to which the explicit message was sent is returned.

**Error code (response):**

An error code defined in EtherNet/IP (1-byte general status and 2-byte additional status) is returned. The data format is DeviceNet-compatible (2 bytes total), so the returned Error Code is converted to the 1-byte general status and a 1-byte additional status (high byte only).

**Description**

- The EXPLICIT MESSAGE SEND command is used to send an EtherNet/IP-defined explicit message to another company's node and receive a response.
- Unlike other FINS commands, the destination of a EXPLICIT MESSAGE SEND command's control data is the local node's EtherNet/IP Unit or built-in EtherNet/IP port, and the actual destination node is specified in the command's route path.

Always specify the local node's EtherNet/IP Unit or built-in EtherNet/IP port in the CMND(490) instruction's control data. An error will occur if another node's Master Unit is specified as the destination.

- When an EtherNet/IP Unit or built-in EtherNet/IP port receives an explicit message, it automatically returns a response to the message.
- A time of 2 s is used for request service processing timeouts. Set the CMND(490) instruction's timeout set value to 2 s or longer. When there is a timeout, the error code will be 0102 hex. When the CMND(490) instruction's timeout set value is less than 2 s, a FINS timeout error response of 0205 hex may occur.

- Note**
1. For details on the parameters of explicit messages, refer to the EtherNet/IP specifications.

2. The Open DeviceNet Vendor Association, Inc. (ODVA) can be contacted at the following address to obtain copies of the EtherNet/IP and CIP specifications.

ODVA Headquarters  
4220 Varsity Drive, Suite A  
Ann Arbor, Michigan 48108-5006  
USA

TEL: 1 734-975-8840

FAX: 1 734-922-0027

Email [odva@odva.org](mailto:odva@odva.org)

WEB [www.odva.org](http://www.odva.org)

### 9-1-1 Sending Explicit Messages Using CMND(490)

With a CS/CJ-series EtherNet/IP Unit or built-in EtherNet/IP port, a CMND(490) in the CPU Unit's ladder program can send CIP UCMM explicit messages.

Send the CIP UCMM explicit message's command data in a FINS command following the 2810 hex FINS command code.

The CIP UCMM explicit message's response is received following the 2810 hex FINS command code and the FINS completion code.

The following command is used: [ CMND S D C ]

S: First command word

D: First response word

C: First control data word

Command data is set in order starting with the word specified for the CMND(490) operand S (first command word) and continuing with words with higher addresses in I/O memory in the command block format.

#### Command Format Example: Get\_Attribute\_All Service to Identity Object

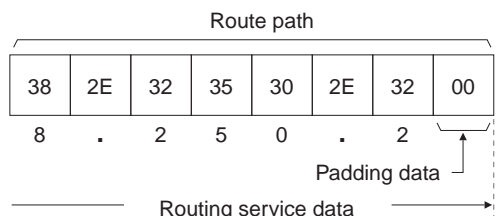
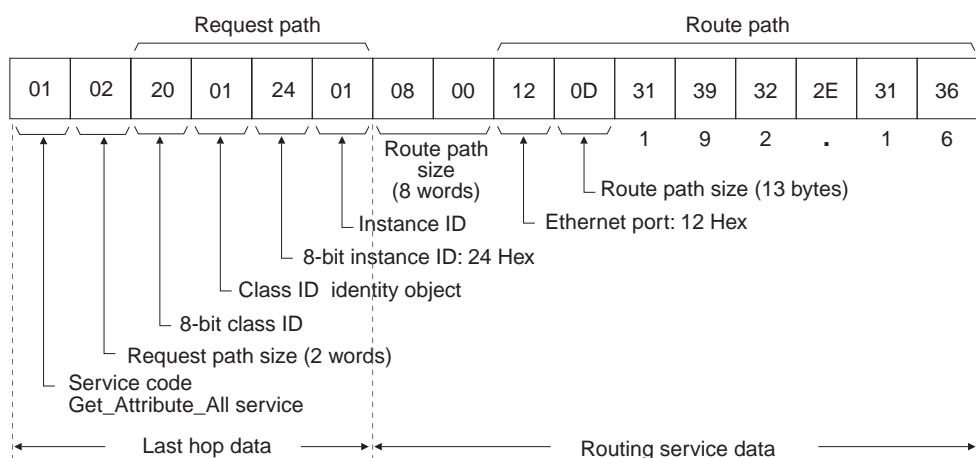
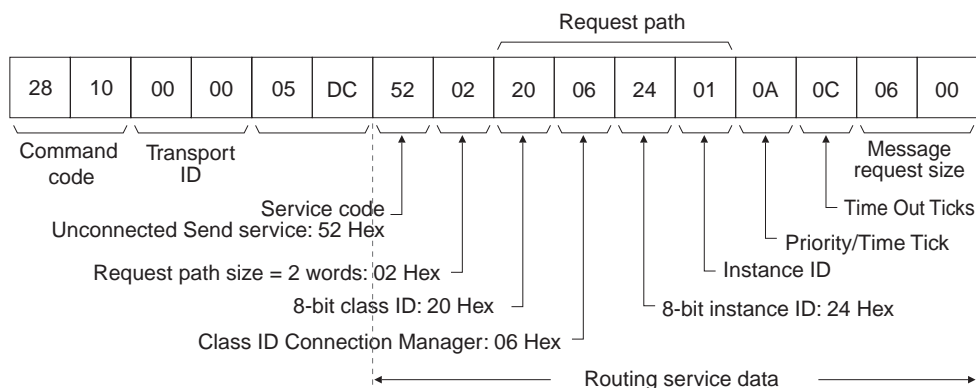



Setting the Command Data for CMND(490)

Bit	15	08	07	00	
S+0	28	10			FINS command code
S+1	00	00			Transport ID
S+2	05	DC			Message monitoring time
S+3	52	02			Service code = 52 hex, Request path size = 02 hex
S+4	20	06			8-bit class ID = 20 hex, Class ID = 06 hex (Connection Manager)
S+5	24	01			8-bit instance ID = 24 hex (request path), Instance ID = 01 hex
S+6	0A	0C			Priority/Time Tick = 0A hex, Time Out Ticks = 0C hex
S+7	06	00			Message request size
S+8	01	02			Service code = 01 hex (Get_Attribute_All service), Request path size = 02 hex
S+9	20	01	} Link	}	8-bit class ID = 20 hex, Class ID = 01 hex (Identity Object)
S+10	24	01			
S+11	08	00			Route path size = 8 words
S+12	12	0D			Ethernet port = 12 hex (Extended Link Address Size = 1 hex, Ethernet port number = 2 hex), Route path size = 13 bytes
S+13	31	39	1	9	} Route path } IP address 192.168.250.2
S+14	32	2E	2	.	
S+15	31	36	1	6	
S+16	38	2E	8	.	
S+17	32	35	2	5	
S+18	30	2E	0	.	
S+19	32	00	2		

The response data is set in the same way, starting from the word specified for CMND(490) operand D (first response word) and continuing with words with higher addresses in I/O memory in the response block format.

**Note** Request path data or request data that is in word (2-byte) or double-word (4-byte) units, such as word data and ERROR CLEAR codes, is specified from low to high (U) bytes in command block format. For example, to specify word data 1234 hex, specify 34 hex and then 12 hex. To specify the double word data 12345678 hex, specify 78 hex, 56 hex, 34 hex, and then 12 hex. The command blocks are shown in the following diagram.

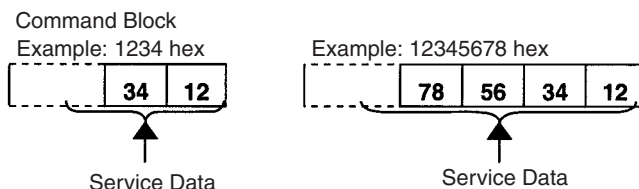

The format from CMND(490) operand S onwards will be set as follows:

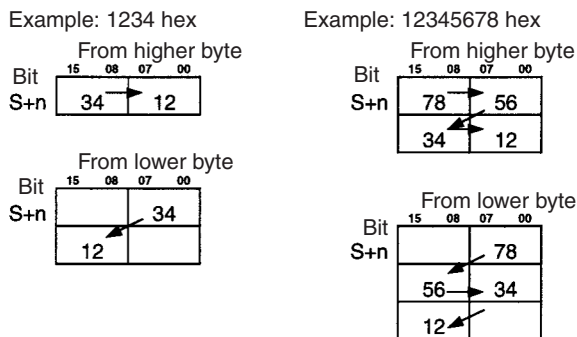

Similarly, when the additional status data and service response data in the response block is in word (2-byte) or double-word (4-byte) units, such as word

data and ERROR CLEAR codes, is also returned in the same order from low to high bytes in the response block.

**Example: Sending Explicit Messages Using CMND(490)**

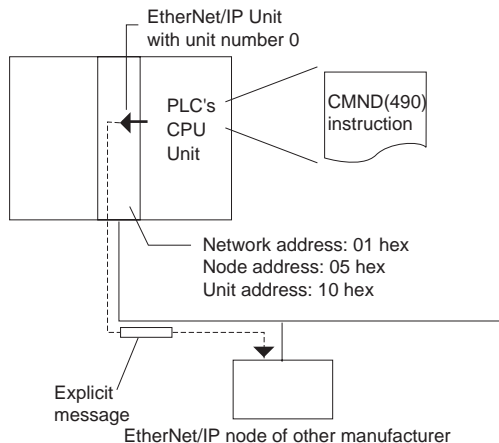

**Operation**

The identity object information (class ID = 01 hex) is read from the other company's EtherNet/IP node at IP address 192.168.250.2, using the CIP UCMM MESSAGE SEND command, 28 10. The command data is stored in the DM Area starting at DM01000, and the response data is stored in the DM Area starting at D02000. If the command ends with an error, the end code is stored in D00006 and command transmission is retried.

**Command Details**

[CMND S D C ]

S = D01000: First command word

D01000 = 2810 hex Command Code

D01001 = 0000 hex Transport ID: 0000 hex

D01002 = 05DC hex Message monitoring time: 15.00 s

D01003 = 5202 hex Slave code: 52 hex (Unconnected Send)

D01004 = 2006 hex Request path size: 2 words

D01004 = 2006 hex Request path: 20 06 24 01 hex (Connection Manager)

D01005 = 2401 hex Class ID: 06 hex

D01005 = 2401 hex Instance ID: 01 hex

Words S+6 to S+19 contain the request data.

D01006 = 0A0C hex Priority/Time\_Tick: 0A hex

D01007 = 0600 hex Time Out Ticks: 0C hex

D01007 = 0600 hex Message request size: 6 bytes

Words S+8 to S+10 contain the request message request.

D01008 = 0102 hex Service: 01 hex (Get\_Attribute\_All)

D01008 = 0102 hex Request path size: 2 words

Words S+9 and S+10 contain the request path.

D01009 = 2001 hex 8-bit class ID: 20 hex

D01009 = 2001 hex Class ID: 01 hex

D01010 = 2401 hex 8-bit instance ID: 24 hex

D01010 = 2401 hex Instance ID: 01 hex (Identity object)

Words S+11 to S+19 contain the root path.

D01011 = 0800 hex Route path size: 8 words

D01012 = 120D hex Extended link address size = 1 hex

D01013 = 3139 hex Route path size: 13 bytes (characters) = 0D hex

D01013 = 3139 hex IP address: "19"

D01014 = 322E hex IP address: "2."

D01015 = 3136 hex IP address: "16"

D01016 = 382E hex      IP address: "8."  
 D01017 = 3235 hex      IP address: "25"  
 D01018 = 302E hex      IP address: "0."  
 D01019 = 3200 hex      IP address: "2"  
                                 Padding data: 00 hex

D = D02000:      First response word at local node  
 C = D00000:      First control word

D00000 = 0028 hex      Number of command bytes: 40 bytes  
 D00001 = 0064 hex      Number of response bytes: 100 bytes  
 D00002 = 0001 hex      Destination network address: 1  
 D00003 = 0510 hex      Destination node address: 5  
                                 Destination unit address: FE hex (or 10 hex)  
 D00004 = 0000 hex      Response, communications port 0, no retries  
 D00005 = 00A0 hex      Response monitoring time: 16.0 s

**Response**

D02000 = 2801 hex      Command code  
 D02001 = 0000 hex      FINS completion code  
 D02002 = 0000 hex      Transport ID  
 D02003 = 001D hex      Number of bytes received: 29 bytes  
 D02004 = 8100 hex      Service code (response): 81 hex  
                                 Reserved: 00 hex  
 D02005 = 0000 hex      General status: 00 hex  
                                 Reserved: 00 hex

Words C+6 to C+18 contain the service response data.

D02006: 2F00 hex  
 D02007: 0C00 hex  
 D02008: 0C00 hex  
 D02009: 0101 hex  
 D020010: 3000 hex  
 D020011: 5303 hex  
 D020012: 0011 hex  
 D020013: 0A43 hex  
 D020014: 5331 hex  
 D020015: 572D hex  
 D020016: 4549 hex  
 D020017: 5032 hex  
 D020018: 3100 hex

Program Example

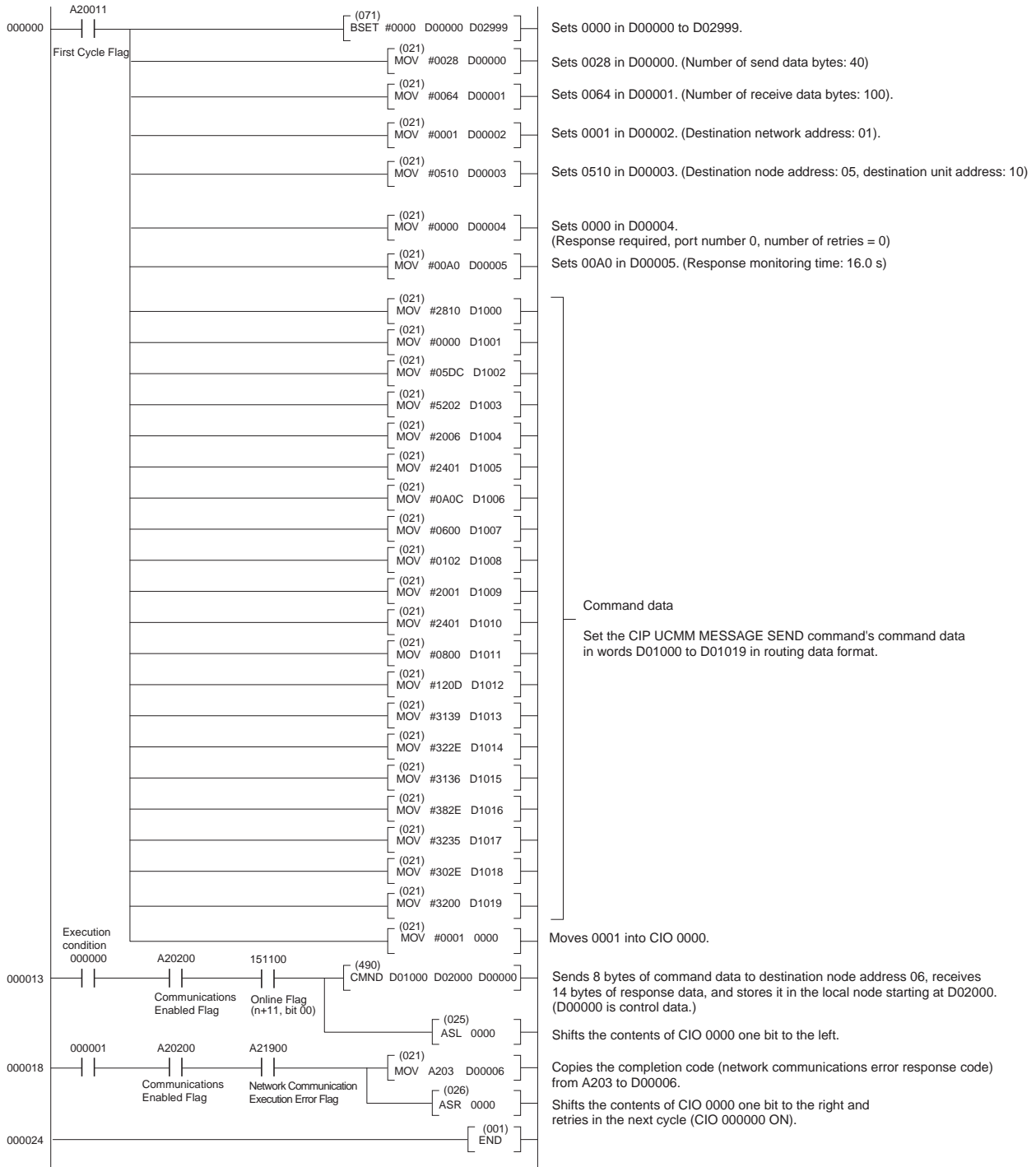

## 9-2 Receiving Explicit Messages

The CS/CJ-series EtherNet/IP Units and built-in EtherNet/IP ports are equipped with a PLC Object that is functionally compatible with CS/CJ-series DeviceNet Units. The Unit will receive messages addressed to the PLC Object, process service requests addressed to the CPU Unit, and return responses. The CS/CJ-series EtherNet/IP Units and built-in EtherNet/IP ports support CIP unconnected message (UCMM) communications and CIP connected (Class 3) communications as reception functions.

The following services are provided by the PLC Object.

- CPU Unit status read/write
- CPU Unit I/O memory read/write
- CPU Unit error log read/clear

Explicit messages can be received from the following sources:

- EtherNet/IP nodes made by other manufacturers
- OMRON PLCs with a CS/CJ-series EtherNet/IP Unit or a CPU Unit with a built-in EtherNet/IP port. (Messages from CS/CJ-series EtherNet/IP Units and built-in EtherNet/IP ports must be CIP unconnected messages (UCMM).)\*

\* Messages from CS/CJ-series EtherNet/IP Units and built-in EtherNet/IP ports must be CIP unconnected messages (UCMM).

### Example

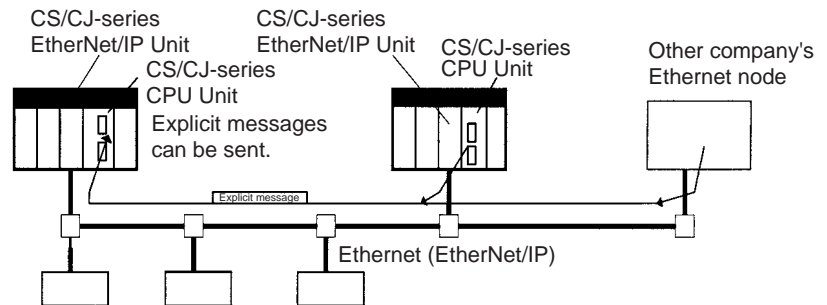

**Note** For an EtherNet/IP Unit or built-in EtherNet/IP port with version 2.0 or higher, change the class ID of the PLC Object from 2F hex to C4 hex. When using a PLC Object with a DeviceNet Unit or EtherNet/IP Unit with version 1.0, and converting to EtherNet/IP Unit or built-in EtherNet/IP port with a version 2.0 or higher, the class ID must be changed according to the communications application.

### 9-2-1 List of PLC Object Services

PLC Objects provide the following services.

#### Status Read/Write for CPU Units

Services	Service code	Class ID	Instance ID	Request service data	Contents
CPU Unit Information Read	0E Hex	C4 Hex (2F Hex) (See note.)	00 Hex	Attribute ID = 64 Hex	Reads the operating mode of the CPU Unit.
				Attribute ID = 65 Hex	Reads if there is a fatal or non-fatal error in the CPU Unit.
				Attribute ID = 66 Hex	Reads CPU Unit model.
CPU Unit Write	10 Hex			Attribute ID = 64 Hex, Attribute Value	Changes the operating mode of the CPU Unit.
				Attribute ID = 65 Hex Attribute Value	Clears errors.
CPU Unit Status Read	40 Hex			None	Reads the detailed status of the CPU Unit. Operation status: Stop, run, CPU standby Operating modes: PROGRAM, MONITOR, RUN Fatal error information: Error flags, including memory errors, I/O bus errors, system errors Messages: Message No. when MSB instruction executed by CPU Unit Error codes: Error code for the most serious errors Error messages: Messages stored in CPU Unit when FAL/FALS instruction executed

I/O Memory Read/Write for CPU Units

Service	Service code	Class ID	Instance ID	Request service data	Contents
Byte Data Read	1C Hex	C4 Hex (2F Hex) (See note.)	Specifies area (01 Hex to 14 Hex)	Address, No. of read bytes	Reads the specified node data in byte units. The word data is read in order, from high to low bytes. Read data: 200 bytes max.
Word Data Read	1D Hex			Address, No. of read words	Reads the specified node data in word units. The word data is read in order, from high to low bytes. Read data: 200 bytes max.
Byte Data Write	1E Hex			Address, byte data	Writes the specified node data in byte units. The word data is specified in order, from high to low bytes. Write data: 200 bytes max.
Word Data Write	1F Hex			Address word data	Writes the specified node data in word units. The word data is specified in order, from high to low bytes. Write data: 200 bytes max.

**Note** With a EtherNet/IP Unit or built-in EtherNet/IP port with unit version 2.0 or later, the PLC object class ID is C4 hex. (With unit version 1.0, the PLC object class ID is F2 hex.)

The commands and responses for the explicit messages that can be sent and received are described on the following pages.

In the following command and response formats, all boxes represent 1 byte each.

**CPU Information Read (Service Code: 0E Hex)**

Reads CPU Unit information, including operating mode, fatal/non-fatal errors, and the CPU Unit model.

**Command Block**

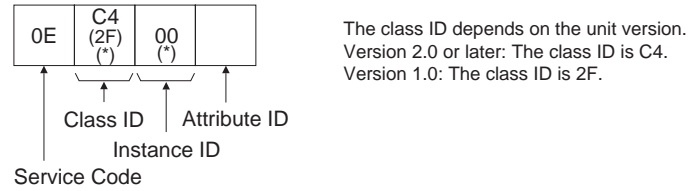

**Note** A body format of either 8 bits or 16 bits is possible.

**Response Block**

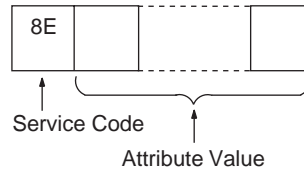

**Parameters**

**Service code (command, response):** 0E Hex is specified for commands. For responses, the highest bit be ON and 8E Hex will be returned.

**Class ID (command):** Always C4 (2F).  
The class ID depends on the unit version. The class ID is C4 for unit version 2.0 or later, and 2F for unit version 1.0.

**Instance ID (command):** Always 00 Hex.

**Attribute ID (command):** The read information is specified by the attribute ID. The attribute IDs are listed in the following table.

Attribute ID (Hex)	Contents	Attribute value size
64	CPU Unit operating mode	1 word (2 bytes)
65	CPU Unit errors	1 word (2 bytes)
66	CPU Unit model	22 bytes

- CPU Operating Mode (when Attribute ID = 64 Hex)  
Reads the CPU Unit operating mode.
- CPU Unit Errors (when Attribute ID = 65 Hex)  
Reads if there are any fatal or non-fatal errors in the CPU Unit.
- CPU Unit Model (when Attribute ID = 66 Hex)  
Reads the CPU Unit model.

**Read data (response):** The specified information is returned in order.

- CPU Unit operating mode (attribute ID = 64 Hex).

The CPU Unit operating mode is returned in 1-word (2-byte) hexadecimal format, as follows:

0001 Hex: PROGRAM mode; 0002 Hex: MONITOR mode;  
0004 Hex: RUN mode

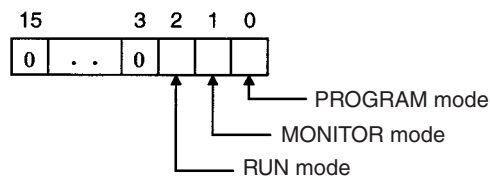



**Note** The codes for the above modes are 1-word (2-byte) data and are returned in low byte first. For example, for PROGRAM mode, the code is returned as 01 Hex followed by 00 Hex.

- CPU Unit Errors (when Attribute ID = 65 Hex)

The CPU Unit fatal/non-fatal error data is returned in 1-word (2-byte) hexadecimal format, as follows:

01 Hex: Error; 00 Hex: No error.

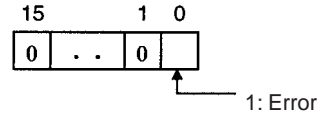

- CPU Unit Model (when Attribute ID = 66 Hex)

The CPU Unit model is returned in ASCII.

Size: 2 bytes (Always 1400 Hex) + Model: 20 bytes (fixed). Unused area is filled with 20 Hex (spaces) and returned.

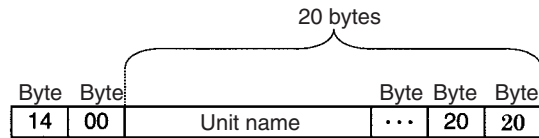

**CPU Unit Write (Service Code: 10 Hex)**

This PLC Object service writes CPU Unit information, including the operating mode and clearing errors.

**Command Block**

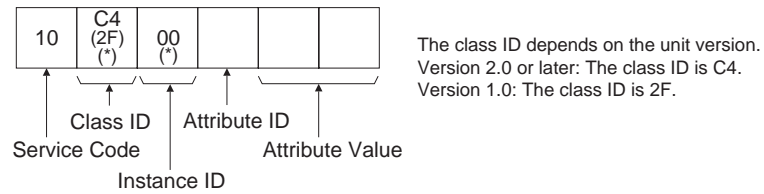

**Note** A body format of either 8 bits or 16 bits is possible.

**Response Block**

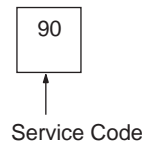

**Parameters**

**Service code (command, response):** 10 Hex is specified for commands. For responses, the highest bit will turn ON and 90E Hex will be returned.

**Class ID (command):** Always C4 (2F).

The class ID depends on the unit version. The class ID is C4 for unit version 2.0 or later, and 2F for unit version 1.0.

**Instance ID (command):** Always 00 Hex.

**Attribute ID (command):** Information to write is specified by the attribute ID. The attribute IDs are listed in the following table.

Attribute ID (Hex)	Contents	Attribute value size
64	CPU Unit operating mode	1 word (2 bytes)
65	CPU Unit errors	1 word (2 bytes)

- CPU Operating Mode (Attribute ID = 64 Hex)  
Changes the CPU Unit operating mode.  
The Attribute Values are as follows:  
0001 Hex: PROGRAM mode; 0002 Hex: MONITOR mode;  
0004 Hex: RUN mode

**Note** The specified code for the above operating modes are 1-word (2-byte) data, and are specified with the low byte first. For example, for PROGRAM mode, the code is specified as 01 Hex followed by 00 Hex. Accordingly, the low to high bytes for the above codes are set as high to low bytes in I/O memory, when setting the codes as data for operand S of CMND(490).

- Clearing CPU Unit Errors (when Attribute ID = 65 Hex)  
Clears any fatal or non-fatal errors in the CPU Unit. Sets the error clear code to Attribute Value. The error clear codes are listed in the following table.

Error code (Hex)	Data cleared
FFFE	Current error (clears the highest priority error)
0008B	Interrupt task error
009A	Basic I/O error
009B	PLC Setup error
02F0	Inner Board non-fatal error
0300 to 035F	Special I/O Unit error
00A0 to 00A1	SYSMAC BUS error
0500 to 055F	Special I/O Unit settings error
00E7	I/O verification error When registered and actual I/O tables are different When disconnecting or connecting I/O Units
00F7	Battery error
0200 to 020F	CS/CJ-series CPU Bus Unit error (last 2 digits are binary code for the Unit No.) For parity errors generated when data transferred between CS/CJ-series CPU Bus Unit and CPU Unit For watchdog timer errors in CS/CJ-series CPU Bus Unit
0400 to 040F	CPU Bus settings error (last 2 digits are binary code for the Unit No.)
4101 to 42FF	System error (FAL): FAL instruction executed

**Note** Error clear codes are 1-word (2-byte) data, so the above codes are specified with the low byte first. The low to high bytes for the above codes are set as high to low bytes in I/O memory, when setting the codes as data for operand S of CMND(490). For example, to specify battery error 00F7 Hex, specify the error code as F7 Hex followed by 00 Hex, as shown in the following diagram.

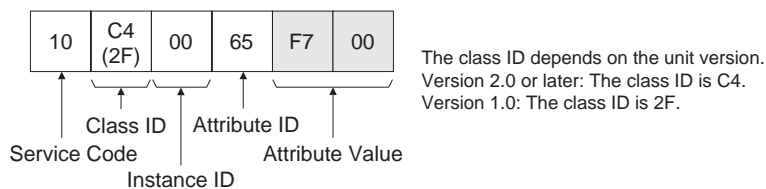

**CPU Unit Status Read (Service Code: 40 Hex)**

This PLC Object service reads status details (operation status, operating mode, fatal and non-fatal errors, etc.) from the CPU Unit.

**Command Block**

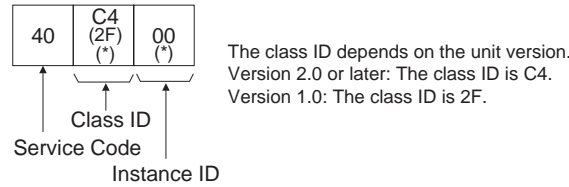

**Note** A body format of either 8 bits or 16 bits is possible.

**Response Block**

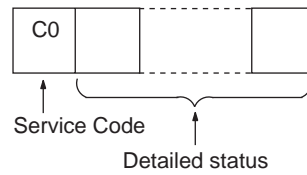

**Parameters**

**Service code (command, response):** 40 Hex is specified for commands. For responses, the highest bit will turn ON and C0 Hex will be returned.

**Class ID (command):** Always C4 (2F).

The class ID depends on the unit version. The class ID is C4 for unit version 2.0 or later, and 2F for unit version 1.0.

**Instance ID (command):** Always 00 Hex.

**Read data (response):** The read data is given in the following table. The data is returned after the service code in the order shown in the table (high to low).

Operation Status
RUN mode
Fatal error information (L)
Fatal error information (H)
Non-fatal error information (L)
Non-fatal error information (H)
Message exists/does not exist (L)
Message exists/does not exist (H)
Error code (L)
Error code (H)
Error message (16 bytes)

- **Operation status:** Returns the operation status of the CPU Unit in 1-byte (2-digit) hexadecimal. The values of bits 3 to 6 are not fixed. Always mask them when addressing the status data.

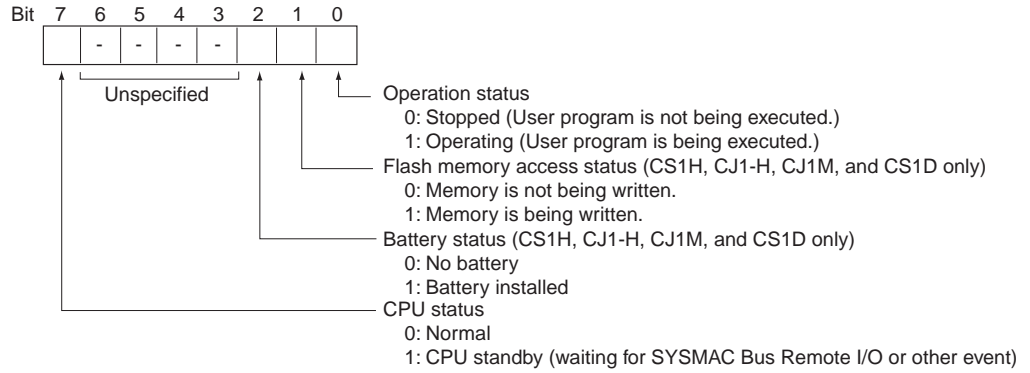

- **Operating mode:** Returns the operating mode of the CPU Unit in 1-byte (2-digit) hexadecimal.  
0001 Hex: PROGRAM mode; 0002 Hex: MONITOR mode;  
0004 Hex: RUN mode
- **Fatal error information:** Returns the fatal error information for the CPU Unit in 2 bytes (low to high).

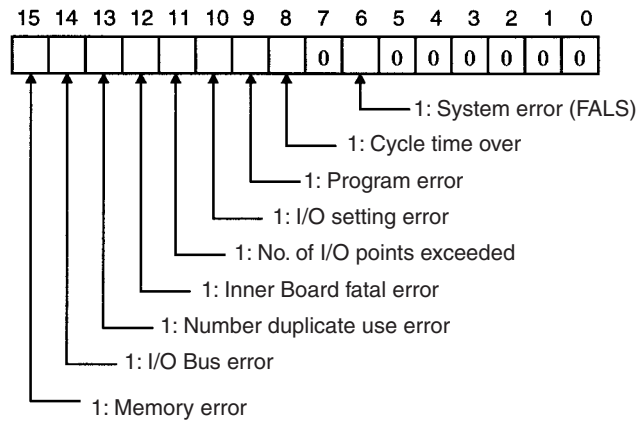

- **Non-fatal error information:** Returns the non-fatal error information for the CPU Unit in 2 bytes (low to high).

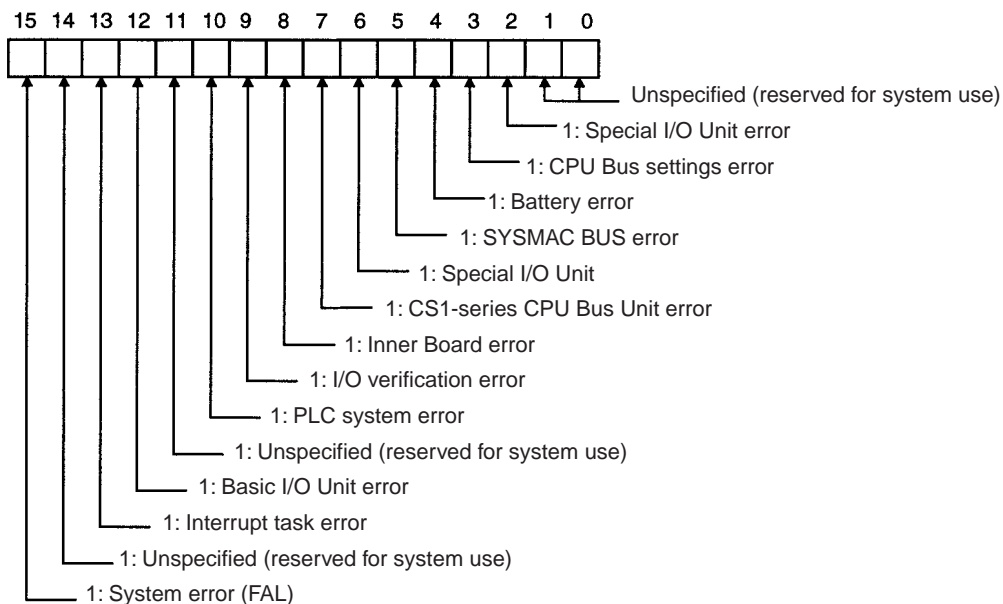

- Message Exists/Does Not Exist:** When the MSG instruction is executed by the CPU Unit, the bit corresponding to the message number will turn ON and be returned in 2 bytes (from low to high bytes).

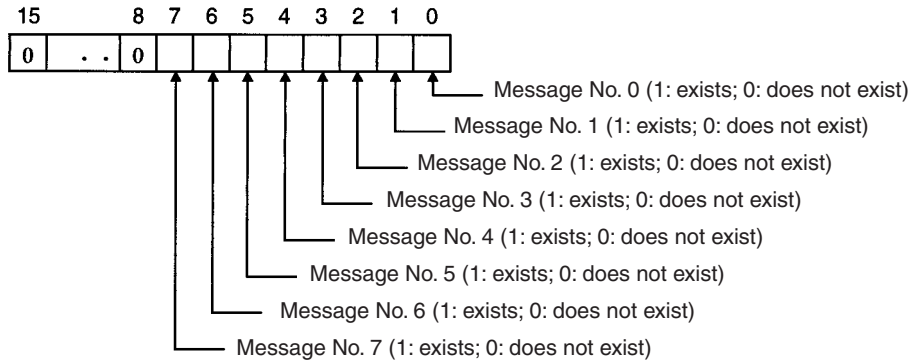

- Error Code:** The highest priority error code of the errors existing when the command is executed will be returned in 2-byte decimal (from low to high bytes). If there are no errors, the error code will be 0000.

**Note** For information on the severity of error codes, refer to the *CS1 Series CPU Unit Operation Manual (W339)* or the *CJ Series CPU Unit Operation Manual (W393)*.

- Error Messages:** If the above error codes have occurred when FAL/FALS instructions are executed with registered messages, those messages are returned in 16-byte ASCII. If there are no registered messages or if the error codes have not occurred due to execution of FAL/FALS instructions, the code is returned in ASCII with 20 Hex (space) in 16 bytes.

### Byte Data Read (Service Code: 1C Hex)

Byte Data Read reads any I/O memory area data in a CPU Unit. The read word data is in byte units. The response block data is returned in low-to-high byte order.

#### Command Block

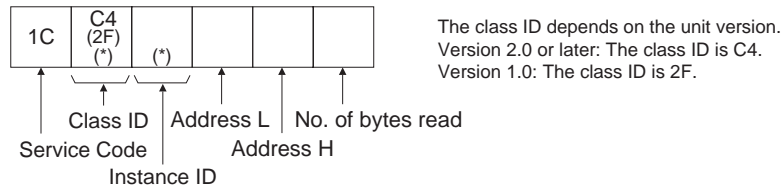

**Note** A body format of either 8 bits or 16 bits is possible.

#### Response Block

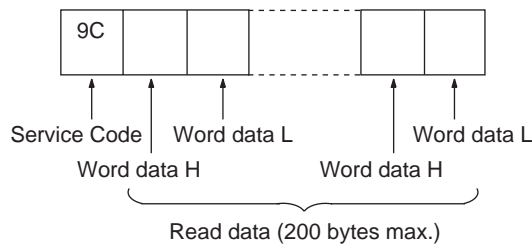

#### Parameters

**Service code (command, response):** 1C Hex is specified for commands. For responses, the highest bit will turn ON and 9C Hex will be returned.

**Class ID (command):** Always C4 (2F).

The class ID depends on the unit version. The class ID is C4 for unit version 2.0 or later, and 2F for unit version 1.0.

**Instance ID (command):** The memory area that will read the data is specified as shown in the following table.

Instance ID (Hex)	CPU Unit memory area for read	Word range
01	CIO	0000 to 6143
03	DM	D00000 to D32767
04	WR	W000 to W511
05	HR	H000 to H1535
08 to 20	EM, banks 0 to 18	En_00000 to En_32767 (n: 0 to 18)

**Address L, Address H (command):** The address of the first word from which to read the data is specified in hexadecimal as shown below.

Address L: The lower 2 digits when the first word address is given in 4-digit hexadecimal.

Address H: The higher 2 digits when the first word address is given in 4-digit hexadecimal.

**No of Read Bytes (command):** The number of bytes of read data is specified in 1-byte (2-digit) hexadecimal. The range is 01 to C8 Hex (1 to 200 decimal).

**No. of bytes received (response):** The number of bytes received from the destination node address (remote node) is returned in hexadecimal.

**Destination node address (response):** The node address of the CS/CJ-series EtherNet/IP Unit or built-in EtherNet/IP port that returned the response is returned in hexadecimal.

**Read data (response):** The specified area, word, and byte data is returned in order from word H (high byte: bits 8 to 15) to word L (low byte: bits 0 to 7). If an odd number is specified for the number of read bytes, the last 1 byte of data will be read to the high word.

**Important Points**

The actual address L, address H, and number of read bytes that can be specified depends on the model of the CPU Unit, and the data area being read. Do not exceed the boundary of the data areas for the PLC you are using.

**Word Data Read (Service Code: 1D Hex)**

Word Data Read reads I/O memory area data in a CPU Unit. The read word data is in word units. The response block data is returned in low-to-high byte order.

**Command Block**

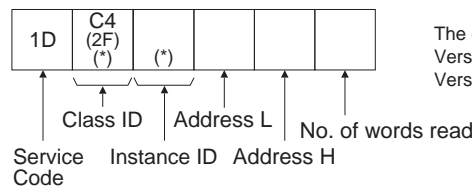

The class ID depends on the unit version.  
Version 2.0 or later: The class ID is C4.  
Version 1.0: The class ID is 2F.

**Note** A body format of either 8 bits or 16 bits is possible.

**Response Block**

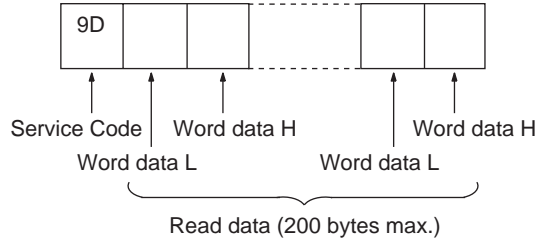

**Parameters**

**Service code (command, response):** ID Hex is specified for commands. For responses, the highest bit will turn ON and 9D Hex will be returned.

**Class ID (command):** Always C4 (2F).  
 The class ID depends on the unit version. The class ID is C4 for unit version 2.0 or later, and 2F for unit version 1.0.

**Instance ID (command):** The type of memory area that will read the data is specified as shown in the following table.

Instance ID (Hex)	CPU Unit memory area for read	Word range
01	CIO	0000 to 6143
03	DM	D00000 to D32767
04	WR	W000 to W511
05	HR	H000 to H1535
08 to 20	EM, banks 0 to 18	En_00000 to En_32767 (n: 0 to 18)

**Address L, Address H (command):** The address of the first word to read the data from is specified in hexadecimal as shown below.

Address L: The lower 2 digits when the first word address is given in 4-digit hexadecimal.

Address H: The higher 2 digits when the first word address is given in 4-digit hexadecimal.

**No of Read Words (command):** The number of words of read data is specified in 1-byte (2-digit) hexadecimal. The range is 01 to 64 Hex (1 to 100 decimal).

**Read data (response):** The specified area, word, and byte data is returned in order from word L (low byte: bits 0 to 7) to word H (high byte: bits 8 to 15).

**Important Points**

The actual address L, address H, and number of write data bytes that can be specified depends on the model of the CPU Unit, and the data area being written. Do not exceed the boundary of the data areas for the PLC you are using.

**Byte Data Write (Service Code: 1E Hex)**

Byte Data Write writes data to an I/O memory area in a CPU Unit. The write word data is in byte units. The command block is specified in high-to-low byte order, as shown in the following diagram.

**Command Block**

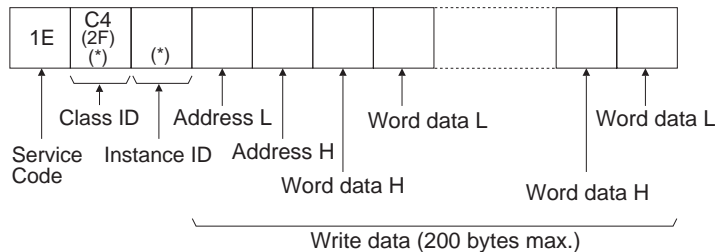

The class ID depends on the unit version.  
Version 2.0 or later: The class ID is C4.  
Version 1.0: The class ID is 2F.

**Note** A body format of either 8 bits or 16 bits is possible.

**Response Block**

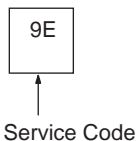

**Parameters**

**Service code (command, response):** IE Hex is specified for commands. For responses, the highest bit will turn ON and 9E Hex will be returned.

**Class ID (command):** Always C4 (2F).

The class ID depends on the unit version. The class ID is C4 for unit version 2.0 or later, and 2F for unit version 1.0.

**Instance ID (command):** The type of memory area to which the data will be written is specified as shown in the following table.

Instance ID (Hex)	CPU Unit memory area for write	Word range
01	CIO	0000 to 6143
03	DM	D00000 to D32767
04	WR	W000 to W511
05	HR	H000 to H1535
08 to 20	EM, banks 0 to 18	En_00000 to En_32767 (n: 0 to 18)

**Address L, Address H (command):** The address of the first word to which the data will be written is specified in hexadecimal as shown below.

Address L: The lower 2 digits when the first word address is displayed in 4-digit hexadecimal.

Address H: The higher 2 digits when the first word address is displayed in 4-digit hexadecimal.

**Write data (response):** The specified area and write data is returned in order from word H (higher byte: bits 8 to 15) to word L (lower byte: bits 0 to 7). For byte data write, specify an even number.

**Important Points**

The actual address L, address H, and number of write data bytes that can be specified depends on the model of the CPU Unit, and the data area being written. Do not exceed the boundary of the data areas for the PLC you are using.

**Word Data Write (Service Code: 1F Hex)**

Word Data Write writes data to any I/O memory area in a CPU Unit. The write word data is in word units. The response block data is returned in low-to-high byte order.



**Command Block**

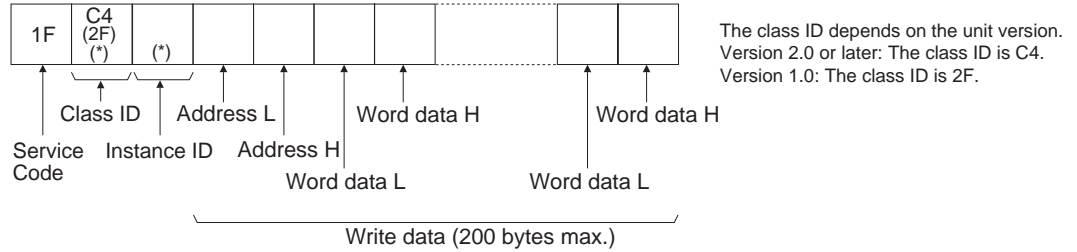

**Note** A body format of either 8 bits or 16 bits is possible.

**Response Block**

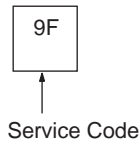

**Parameters**

**Service code (command, response):** 1F Hex is specified for commands. For responses, the highest bit will turn ON and 9F Hex will be returned.

**Class ID (command):** Always C4 (2F).  
The class ID depends on the unit version. The class ID is C4 for unit version 2.0 or later, and 2F for unit version 1.0.

**Instance ID (command):** The memory area to which the data is written is specified as shown in the following table.

Instance ID (Hex)	CPU Unit memory area for write	Word range
01	CIO	0000 to 6143
03	DM	D00000 to D32767
04	WR	W000 to W511
05	HR	H000 to H1535
08 to 20	EM, banks 0 to 18	En_00000 to En_32767 (n: 0 to 18)

**Address L, Address H (command):** The address of the first word to which the data is written is specified in hexadecimal as shown below.

Address L: The lower 2 digits when the first word address is displayed in 4-digit hexadecimal.

Address H: The higher 2 digits when the first word address is displayed in 4-digit hexadecimal.

**Write data (response):** The specified area and write data is returned in order from word L (lower byte: bits 0 to 7) to word H (higher byte: bits 8 to 15).

**Important Points**

The actual address L, address H, and number of write data bytes that can be specified depends on the model of the CPU Unit, and the data area being written. Do not exceed the boundary of the data areas for the PLC you are using.



# SECTION 10

## Communications Performance and Communications Load

This section describes the communications performance in an EtherNet/IP network, and shows how to estimate the I/O response times and transmission delays.

10-1	Communications System . . . . .	264
10-1-1	Tag Data Link Communications Method . . . . .	264
10-1-2	Calculating the Number of Connections . . . . .	266
10-1-3	Network Transmission Delay Time . . . . .	267
10-2	Adjusting the Communications Load . . . . .	270
10-2-1	Checking Bandwidth Usage for Tag Data Links . . . . .	271
10-2-2	Tag Data Link Bandwidth Usage and RPI . . . . .	272
10-2-3	Adjusting Device Bandwidth Usage . . . . .	273
10-2-4	Changing the RPI . . . . .	274
10-2-5	RPI Setting Examples . . . . .	278
10-3	I/O Response Time in Tag Data Links . . . . .	285
10-3-1	Timing of Data Transmissions . . . . .	285
10-3-2	EtherNet/IP Unit or CJ2H Built-in Port Data Processing Time . . . . .	285
10-3-3	Effect on the CPU Unit's Cycle Time . . . . .	286
10-3-4	Tag Data Link I/O Response Time Calculation Example . . . . .	287
10-4	Tag Data Link Performance for CJ2M Built-in EtherNet/IP Ports . . . . .	293
10-4-1	Overview . . . . .	293
10-4-2	Tag Data Link I/O Response Time . . . . .	294
10-5	Message Service Transmission Delay . . . . .	296
10-5-1	Maximum Transmission Delays (Excluding Delays in the Network)	296

# 10-1 Communications System

## 10-1-1 Tag Data Link Communications Method

### Packet Interval (RPI) Settings

In EtherNet/IP tag data links, the data transmission period is set for each connection as the packet interval (RPI). The target device will send data (i.e., output tags) once each packet interval (RPI), regardless of the number of nodes. Also, the heartbeat frame is sent from the originator to the target for each connection. The target uses the heartbeat to check to see if errors have occurred in the connection with the originator. The data transmission period of the heartbeat frame depends on the packet interval (RPI) settings.

#### ■ Heartbeat Frame Transmission Period

- Packet interval < 100 ms  
The heartbeat frame transmission period is 100 ms.
- Packet interval ≥ 100 ms  
The heartbeat frame transmission period is the same as the RPI.

#### Example

In this example, 2 tag data link connections are set for node 2 (the originator) and node 1 (the target).

The packet interval (RPI) for output data 1 is set to 10 ms.

The packet interval (RPI) for output data 2 is set to 15 ms.

In this case, output data 1 is sent from node 1 to node 2 every 10 ms, and output data 2 is sent from node 1 to node 2 every 15 ms, as shown in the following diagram. Also, data is sent from node 2 (the originator) to node 1 (the target) with a heartbeat of 100 ms for connection 1 and a heartbeat of 100 ms for connection 2.

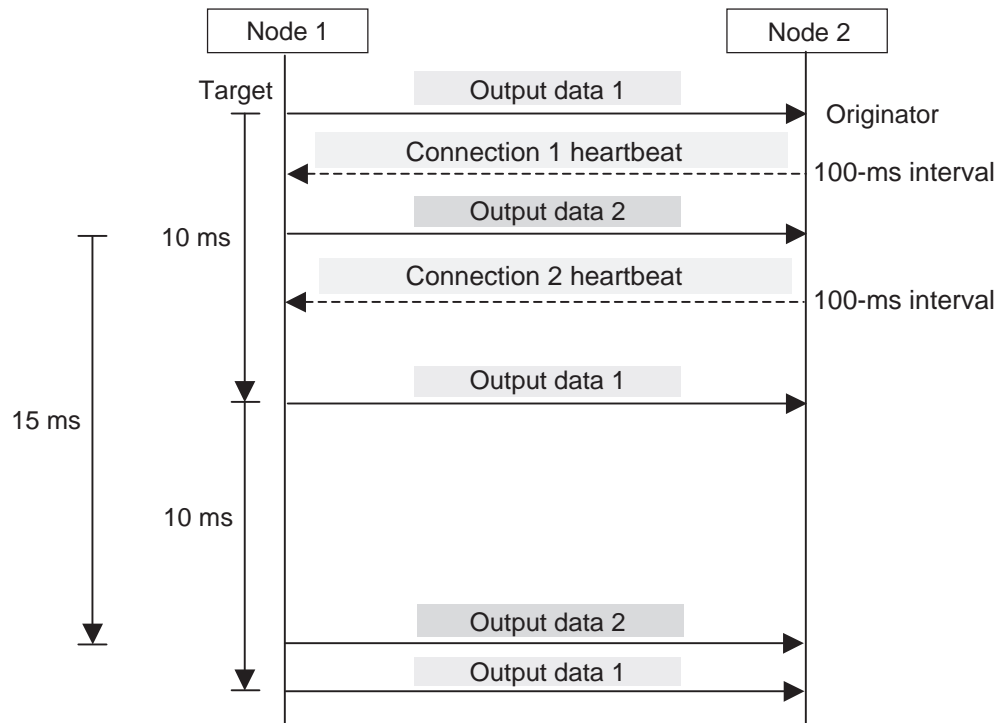

**Packet Interval (RPI) and Bandwidth Usage (PPS)**

In a tag data link, the number of packets transferred each second is called the bandwidth used or PPS (packets per second).

The PPS is calculated from the RPI and heartbeat as follows for each connection:

$$\text{PPS used in a connection (pps)} = (1,000 \div \text{RPI (ms)}) + (1,000 \div \text{Heartbeat transmission period (ms)})$$

The following equation is used to calculate the total number of packets transferred by each EtherNet/IP Unit or built-in EtherNet/IP port in 1 second.

$$\text{Unit's total PPS} = \text{Total PPS of originator connections} + \text{Total PPS of target connections (See note.)}$$

**Note** Connections set as target connections must be added, too.

The maximum number of packets that the Unit can transfer in 1 second (called the allowed Unit bandwidth) is 6,000 pps (CJ2M-EIP21: 3,000 pps), so set the connection below this maximum value.

**Example**

Node 1 has both originator and target connections, with send RPI of 200 ms and 2 ms, and receive RPI of 1 ms.

Node 2 has originator connections only, with receive RPI of 200 ms, 2 ms, and 5 ms.

Node 3 has target connections only, with send RPI of 5 ms and 1 ms.

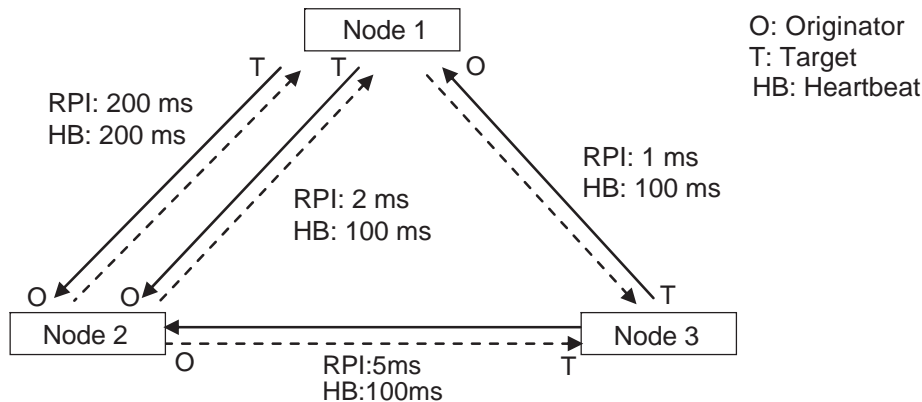

Each node's total PPS is calculated as follows.

- Total PPS of node 1 Unit
  - = 1,000 / 200 ms + 1,000 / 2 ms + 1,000 / 1 ms (for data)
  - + 1,000 / 200 ms + 1,000 / 100 ms + 1,000 / 100 ms (for heartbeat)
  - = 1,530 pps
- Total PPS of node 2 Unit
  - = 1,000 / 200 ms + 1,000 / 2 ms + 1,000 / 5 ms (for data)
  - + 1,000 / 200 ms + 1,000 / 100 ms + 1,000 / 100 ms (for heartbeat)
  - = 730 pps
- Total PPS of node 3 Unit
  - = 1,000 / 5 ms + 1,000 / 1 ms (for data)
  - + 1,000 / 100 ms + 1,000 / 100 ms (for heartbeat)
  - = 1,220 pps

All of the Units are within the allowed Unit bandwidth of 6,000 pps (CJ2M-EIP21: 3,000 pps), so they can transfer data.

### 10-1-2 Calculating the Number of Connections

The maximum number of connections for the Unit is 32 for the CJ2M-EIP21 and 256 for other CPU Units.

The number of connections must be set to 32 or less for the CJ2M-EIP21 and 256 or less for other CPU Units combining both connections that the Unit opens as the originator and connections that are opened from an originator with the Unit as the target.

**Example**

Node 1 opens two connections as the target with node 2 and one connection as the originator with node 3. Therefore, the total is three connections. Node 2 opens two connections as the originator with node 1 and one connection as the target with node 3. Therefore, the total is three connections. Node 3 opens one connection as the target with node 1 and one connection as the target with node 2. Therefore, the total is two connections. In either case, the connections can be opened because the maximum number of connections for the Unit is less than 32 for the CJ2M-EIP21 and less than 256 for other CPU Units.

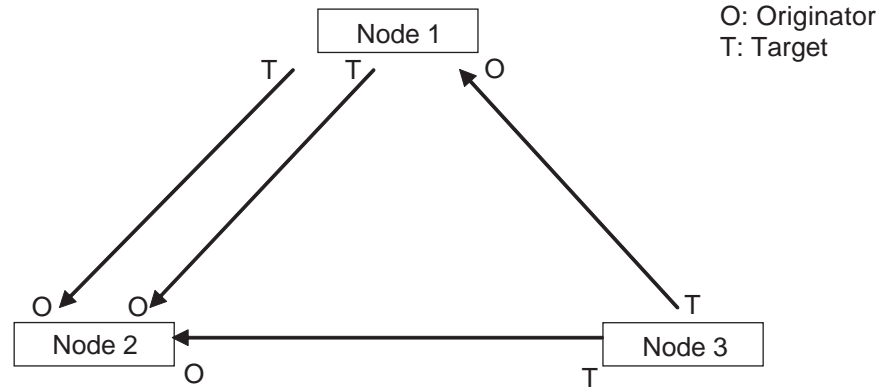

Also, if multicast is set, one packet will be sent, but the number of connections will be consumed.

**Example**

Node 3 sends one multicast packet to node 1 and node 2. At that time, node 3 opens one connection as the target with node 1 and one connection as the target with node 2 for a total of two connections. Caution is required because the number of connections consumed is the same as for unicast connections even when multicast connections are set.

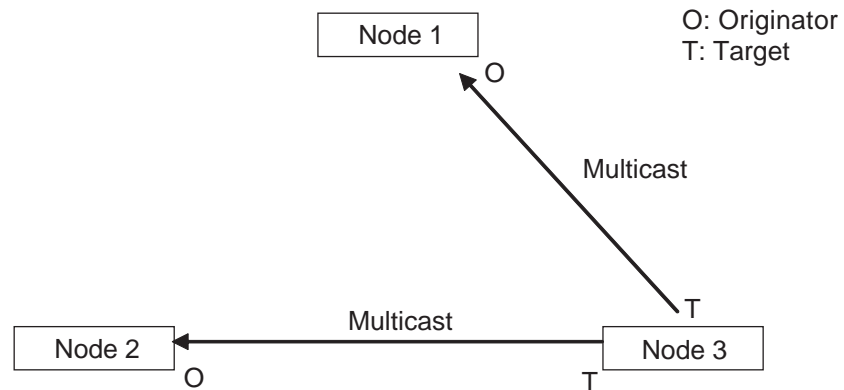

### 10-1-3 Network Transmission Delay Time

In an EtherNet/IP network, the tag data link packets are sent once each packet interval (RPI), but several delays occur between the transmission of packets from each node and the arrival of the packets at the destination nodes. The following diagram shows the 4 major delay sources.

Total network transmission delay = (1) Send processing delay + (2) Cable delays + (3) Switching hub delay + (4) Receive processing delay

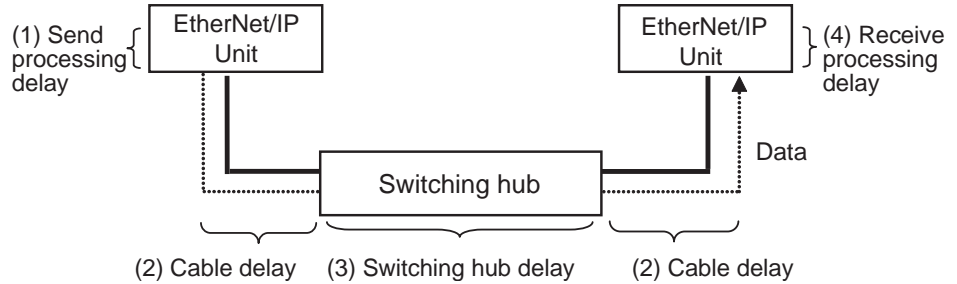

The lengths of these delays depend on many factors, such as the tag data link connection settings (number of connections and data sizes), number of nodes, the switching hub being used, and cable lengths. Each delay is described in detail below.

#### 1. Send Processing Delay

The send processing delay is the delay that occurs within the EtherNet/IP Unit or built-in EtherNet/IP port when data packets are sent once each packet interval. This delay varies with the RPI error shown in the following graph, so the send processing time is the maximum value for each RPI.

Packet interval (RPI)	RPI error (±) (%)
0.5 to 1,000 ms	15 – (RPI (ms) ÷ 100)
1,000 ms to 10,000 ms	5% of the RPI

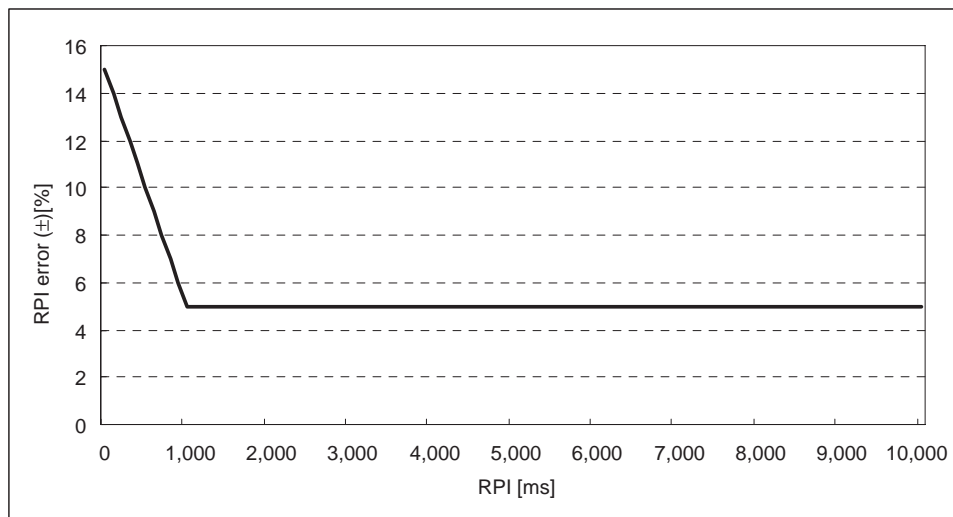

#### 2. Cable Delay

The cable delay is the time required for the data signal to pass through the cable and reach the destination. When an STP (shielded twisted-pair) cable of category 5, 5e, or higher is being used, the maximum cable delay is 545 ns/100 m. The cable delay represents a very small percentage of the total tag data link delay.

**3. Switching Hub Delay**

The switching hub delay is the delay time between the arrival of the packet at the switching hub and the output of the packet from the hub’s transmission port. This delay depends on the total number of connections used for reception and data sizes used in the tag data links. In addition, this delay depends on the switching hub maker and model, but the delay can be approximated with the following table. (For a precise estimate, contact the switching hub manufacturer.)

The following values are the delays when cascade connections are not being used. If cascade connections are used, more nodes can be connected, but the switching hub delays will increase.

Words per connection	Number of connections used for reception				
	16	32	64	128	256
2 words	0.2 ms	0.3 ms	0.5 ms	1.0 ms	1.9 ms
200 words	0.7 ms	1.3 ms	2.5 ms	5.0 ms	10.0 ms
400 words	1.2 ms	2.3 ms	4.6 ms	9.1 ms	18.2 ms
600 words	1.7 ms	3.3 ms	6.6 ms	13.2 ms	26.4 ms
722 words	2.0 ms	4.0 ms	7.9 ms	15.7 ms	31.4 ms

**4. Receive Processing Delay**

The receive processing delay is the delay that occurs within the EtherNet/IP Unit or built-in EtherNet/IP port from the reception of the data packet at the Unit until the completion of reception processing in the Unit. This delay depends on the size of the connections used in the tag data links and the number of connections. In practice, the delay depends on the number of connections used in tag data links with less than 200 words. If the number of connections is “n”, the maximum delay can be calculated with the following equation.

$$\text{Maximum reception processing delay} = 1 + (n \times 0.043) \text{ ms}$$

The size of the connections may cause a delay when the data sizes are smaller and a large number of packets may be received in a fixed interval, because the data may wait for receive processing.

**Example Calculation of the Tag Data Link Delay**

This example shows how to calculate the tag data link delay when the following tag data link connection settings have been made.

In this case, 17 EtherNet/IP Units or built-in EtherNet/IP ports are being used, and one Unit is receiving 200 words of data from each of the other Units at a packet interval (RPI) of 5 ms. Thus, 16 tag data link connections are used. The length of the cables between the Units is 50 m for all connections.

$$\text{Send processing delay} = 5 \text{ ms} \times (15 - 5/100)\% = 0.7475 \text{ ms}$$

$$\text{Cable delay} = 545 \text{ ns} \times 50 \text{ m}/100 = 272.5 \text{ ns}$$

$$\text{Switching hub delay} = 0.7 \text{ ms}$$

$$\text{Receive processing delay} = 1 + (16 \times 0.043) \text{ ms} = 1.688 \text{ ms}$$

$$\begin{aligned} \text{Tag data link delay} &= 0.7475 \text{ ms} + 0.0002725 \text{ ms} + 0.7 \text{ ms} + 1.688 \text{ ms} \\ &\approx 3.14 \text{ ms} \end{aligned}$$



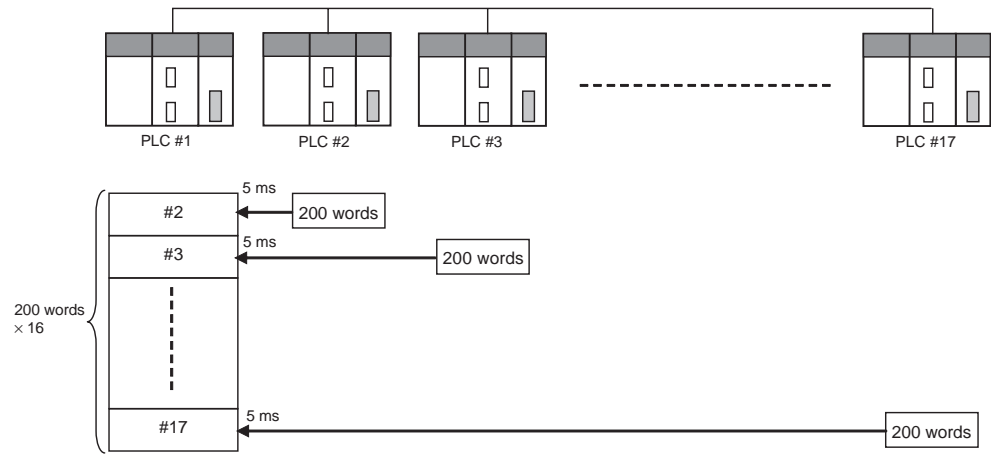

## 10-2 Adjusting the Communications Load

In an Ethernet network using a switching hub, the network bandwidth is not shared by all of the nodes; independent transmission paths are established between individual nodes through the switching hub.

A dedicated communications buffer is established in the switching hub for communications between the nodes and full-duplex communications (simultaneous transmission and reception) are performed asynchronously with other transmission paths. The communications load in other transmission paths does not affect communications, so packet collisions do not occur and stable, high-speed communications can be performed.

The switching hub functions shown in the following table determine the performance of tag data links.

Item	Description
Buffer capacity	This is the amount of data that can be buffered when packets accumulate at the switching hub.
Multicast filtering	This function transfers multicast packets to specific nodes only.
QoS function	This function performs priority control on packet transfers.

The following table shows the tag data link settings that can be made for individual EtherNet/IP Units as well as the setting ranges.

Item	Contents	Settings
Network bandwidth	Physical Ethernet baud rate	100 Mbps or 10 Mbps
Allowed tag data link communications bandwidth	Maximum number of tag data link packets that can be processed in 1 second (pps: packets per second)	CJ2M-EIP21: 3,000 pps max. Other CPU Units: 6,000 pps max.
Connection resources	Number of connections that can be established	CJ2M-EIP21: 32 max. Other CPU Units: 256 max.
Packet interval (RPI: Requested Packet Interval)	Refresh cycle for tag data	CJ2M-EIP21: 1 to 1,000 ms Other CPU Units: 0.5 to 10,000 ms (in 0.5 ms units)

When the tag data link settings exceed the capabilities of the switching hub being used, increase the RPI value. Particularly when using a switching hub that does not support multicast filtering, the settings must be made considering that multicast packets will be sent even to nodes without connection settings.

In addition, if the required tag data link performance cannot be achieved with the switching hub's capabilities, reevaluate the overall network configuration and correct it by taking steps such as selecting a different switching hub or splitting the network.

The following sections show how to check the device bandwidth being used by the tag data links in the designed network, and how to set the appropriate values.

**Note** If the Network Configurator is used to set the connection type in the connection settings to a multicast connection, multicast packets will be used. If the connection type is set to a point-to-point connection, multicast packets will not be used.

### 10-2-1 Checking Bandwidth Usage for Tag Data Links

The Network Configurator can display the bandwidth actually used for tag data links at each EtherNet/IP Unit, based on the connections set in the network configuration.

The device bandwidth used by tag data links can be checked by clicking the **Detail** Button in the Usage of Device Bandwidth Area at the bottom of the Network Configuration Window.

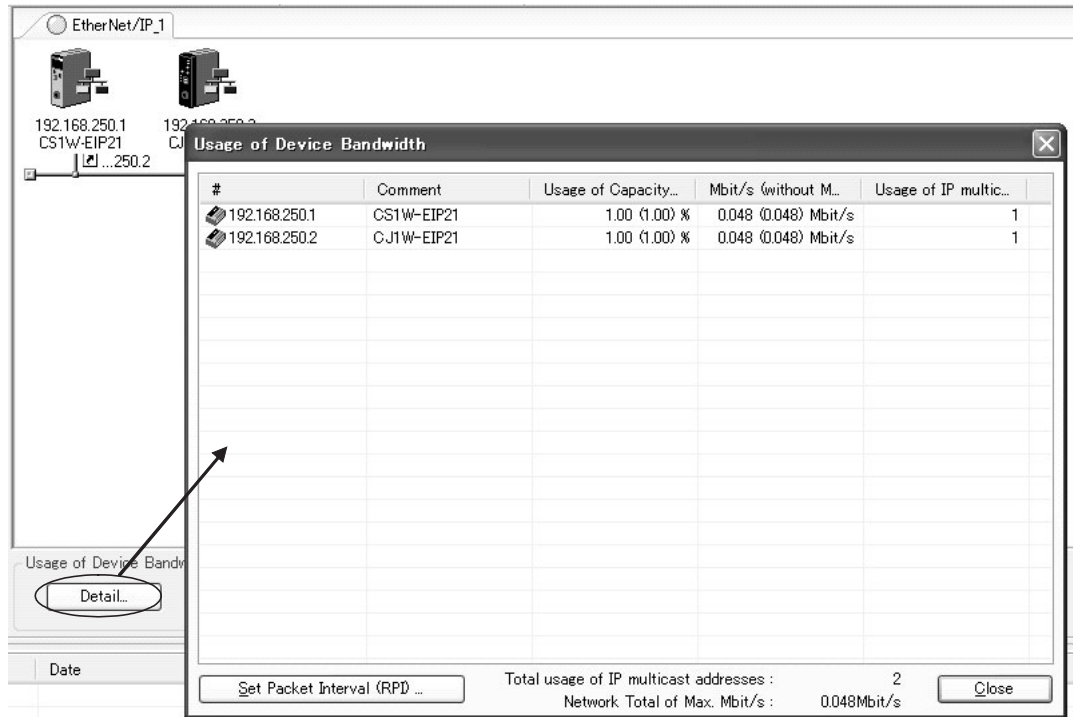

Item	Description
#	The IP address of the device.
Comment	A description of the device. The comment is displayed below the device icon. The model number of the device is displayed by default.
Usage of Capacity	The percentage of the allowable communications bandwidth used for tag data links for the device is displayed. Bandwidth used ÷ Allowable tag data link bandwidth The values outside parentheses are for when multicast filtering is used. The values inside parentheses are for when multicast filtering is not used.
Mbit/s	The bandwidth used for communications by the device of the 100-Mbps network bandwidth is shown. The values outside parentheses are for when multicast filtering is used. The values inside parentheses are for when multicast filtering is not used.
Usage of IP Multi-cast Addresses	The number of multicast IP addresses actually used for communications by the device is shown.

Item	Description
Total usage of IP multicast addresses	The number of multicast IP addresses used in the entire network is shown. This value is used to estimate the number of multicast filters for switching.
Network Total of Max. Mbit/s	The total network bandwidth used for tag data link communications in the entire network is shown. Tag data links will not operate normally if 100 Mbps is exceeded for the network bandwidth.

### Checking the Usage of Capacity and Network Bandwidth for Tag Data Links

The percentage of the allowable communications bandwidth for tag data links for each EtherNet/IP Unit is displayed as the *Usage of Capacity* and the bandwidth used for tag data link communications in the entire network is displayed as the *Mbit/s*.

The usage of capacity and used network bandwidth that are displayed in parentheses are for a switching hub that does not use multicast filtering. In this case, multicast packets will be sent to even the nodes without connection settings, so the displayed values will include these packets as well.

These values can be adjusted according to instructions in *10-2-4 Changing the RPI*.

### Checking the Total Number of Multicast IP Addresses in the Network

When using a switching hub that provides multicast filtering, there must be enough multicast filters for the network being used. The number of multicast IP address used in the entire network that is displayed by the Network Configurator as the *Network Total of Max. Mbit/s* is based on connection settings.

Make sure that the number of multicast IP addresses used in the entire network does not exceed the number of multicast filters supported by the switching hub. If necessary, change to a switching hub with enough multicast filters, or adjust the usage of capacity and network bandwidth for tag data links (*Mbit/s*) values given for a switching hub without multicast filtering (i.e., the values in parentheses). Adjust these values according to instructions in *10-2-4 Changing the RPI*.

### Checking the Total Maximum Network Bandwidth

The Network Configurator displays the total maximum bandwidth that can be used for the entire network as the *Network Total of Max. Mbit/s*. This value indicates the maximum bandwidth that can be used on the transmission paths when switching hubs are cascaded. If the value exceeds the bandwidth of a cascade connection in the actual network, the maximum bandwidth for part of the communications path may be exceeded, depending on how the network is wired.

If this occurs, either calculate the bandwidth usage for each communications path and be sure that the maximum bandwidth is not exceeded for any cascade connection, or adjust the bandwidth for all cascade connections so that the total maximum network bandwidth is not exceeded. Adjust the bandwidth according to instructions in *10-2-4 Changing the RPI*.

## 10-2-2 Tag Data Link Bandwidth Usage and RPI

The usage of capacity can be adjusted using the RPI setting. If the RPI is made shorter, the usage of capacity will increase. If the RPI is made longer, the usage of capacity will decrease.

The RPI can be set in any one of the following ways.

- Setting the same interval for all connections
- Setting a particular device's connection
- Setting a particular connection

When the same RPI is set for all connections, the usage of capacity will basically increase proportionally as the RPI is made shorter.

Example:

If the RPI is set to 50 ms for all connections and the usage of capacity is 40%, the usage of capacity may increase to 80% when the RPI is reduced to 25 ms for all connections.

**Note** Performing message communications or other network operations from the Network Configurator (such as monitoring or other operations that place a load on the network) or from the user application when the tag data link bandwidth usage of capacity is between 80% and 100% can create an excessive load on the network and result in timeouts. If timeouts occur, increase one or all of the RPI settings or reduce the usage of capacity.

### 10-2-3 Adjusting Device Bandwidth Usage

#### Switching Hubs without Multicast Filtering (100-Mbps Hubs)

- Is the network bandwidth without multicast filtering usage under 100 Mbps for each node? (This appears as “Mbit/s” in the dialog box shown on page 271.)  
→ If any node exceeds 100 Mbps, change the connections settings, such as the RPI.
- Is the usage of capacity without multicast filtering under 100% for each node? (This appears as “Usage of Capacity” in the dialog box shown on page 271.)  
→ If any node exceeds 100%, change the connections settings, such as the RPI.
- Is the total network bandwidth usage under 100 Mbps? (This appears as “Network Total of Max. Mbit/s” in the dialog box shown on page 271.)  
→ If the total bandwidth usage exceeds 100 Mbps, the bandwidth of part of the transmission path (e.g., a switching hub or media converter) had been exceeded as the result of how the network was wired (e.g., switch hub or cascade connection), causing a tag data link to operate abnormally. Check the bandwidth of the transmission path for all cascade connections. If the bandwidth is exceeded, rewire the network or increase the bandwidth between switching hubs (e.g., to 1 Gbps). If these countermeasures are not possible, change the connection settings, e.g., the RPI settings, and adjust the bandwidth for all cascade connections until the total network bandwidth is not exceeded.

#### Switching Hubs with Multicast Filtering (100-Mbps Hubs)

- Is the network bandwidth usage under 100 Mbps for each node?  
→ If any node exceeds 100 Mbps, change the connections settings, such as the RPI.
- Is the usage of capacity under 100% for each node?  
→ If any node exceeds 100%, change the connections settings, such as the RPI.
- Is the total network bandwidth usage under 100 Mbps? (This appears as “Network Total of Max. Mbit/s” in the dialog box shown on page 271.)  
→ If the total bandwidth usage exceeds 100 Mbps, the bandwidth of part of the transmission path (e.g., a switching hub or media converter) had been exceeded as the result of how the network was wired (e.g., switch hub or cascade connection), causing a tag data link to operate abnormally. Check the bandwidth of the transmission path for all cascade connections. If the bandwidth is exceeded, rewire the network or increase the bandwidth between switching hubs (e.g., to 1 Gbps). If these countermeasures are not possible, change the connection settings, e.g., the RPI settings, and adjust the bandwidth for all cascade connections until the total network bandwidth is not exceeded.

- Is the network bandwidth usage without multicast filtering under 100 Mbps for each node or the usage of capacity without multicast filtering under 100% for each node? (These appear as “Mbit/s” and “Usage of Capacity” in the dialog box shown on page 271.)
  - If the total bandwidth usage exceeds 100 Mbps, the bandwidth of part of the transmission path (e.g., a switching hub or media converter) had been exceeded as the result of how the network was wired (e.g., switch hub or cascade connection), causing a tag data link to operate abnormally. Check the bandwidth of the transmission path for all cascade connections. If the bandwidth is exceeded, rewire the network or increase the bandwidth between switching hubs (e.g., to 1 Gbps). If these countermeasures are not possible, change the connection settings, e.g., the RPI settings, and adjust the bandwidth for all cascade connections until the total network bandwidth is not exceeded.

### 10-2-4 Changing the RPI

You can check the usage of capacity offline without multicast filtering against the tag data link's allowable bandwidth by following the procedures in *10-2-1 Checking Bandwidth Usage for Tag Data Links*. The usage of capacity without multicast filtering can be adjusted against the tag data link's allowable bandwidth by changing the packet interval (RPI). If the required communications performance cannot be achieved by changing the settings, reevaluate the network starting with the network configuration.

- 1,2,3...**
1. Make the required settings in the Network Configurator's Network Configuration Window.
  2. Click the **Detail** Button in the Usage of Device Bandwidth Area at the bottom of the Network Configuration Window.

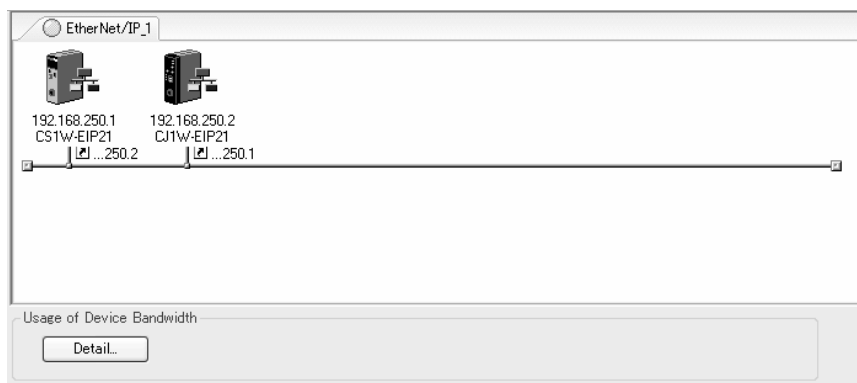

The Usage of Device Bandwidth Dialog Box will be displayed.

#	Comment	Usage of Capacity...	Mbit/s (without M...	Usage of IP multic...
192.168.250.1	CS1W-EIP21	1.00 (1.00) %	0.048 (0.048) Mbit/s	1
192.168.250.2	CJ1W-EIP21	1.00 (1.00) %	0.048 (0.048) Mbit/s	1

Buttons: Set Packet Interval (RPI) ..., Total usage of IP multicast addresses : 2, Network Total of Max. Mbit/s : 0.048Mbit/s, Close

The *Usage of Capacity* column will show the percentage of the allowed tag data link bandwidth being used, and the *Mbit/s* column will show the network bandwidth being used.

3. The usage of capacity can be adjusted by changing the associated devices' RPI settings.

The RPI settings can be changed with the following three methods.

**Method 1: Same Packet Interval Set for all Connections**

The usage of capacity can be adjusted by changing the RPI for all of the connections at the same time.

- a. Click the **Set Packet Interval (RPI)** Button at the bottom of the Usage of Device Bandwidth Dialog Box.

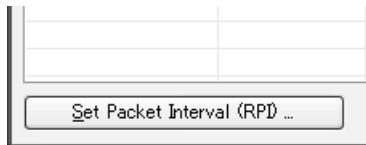

- b. The Set Packet Interval (RPI) Dialog Box will be displayed. Input a new RPI value, and click the **OK** Button.

Packet Interval (RPI): 50.0 ms ( 0.5 - 10000.0 ms )

Target Device:

- 192.168.250.1 CS1W-EIP21
- 192.168.250.2 CJ1W-EIP21

Buttons: OK, Cancel

**Method 2: Changing a Particular Device's RPI Setting**

The usage of capacity can be adjusted for only a particular device by changing the packet intervals (RPI) for all of the device's connections together. In this case, the usage of capacity will also change for the devices that are the target devices of the connection which was adjusted.

- a. Click the **Set Packet Interval (RPI)** Button at the bottom of the Usage of Device Bandwidth Dialog Box.

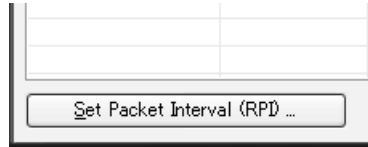

- b. The Set Packet Interval (RPI) Dialog Box will be displayed. In the *Target Device Area*, deselect the target devices that are not being adjusted by removing the check marks.

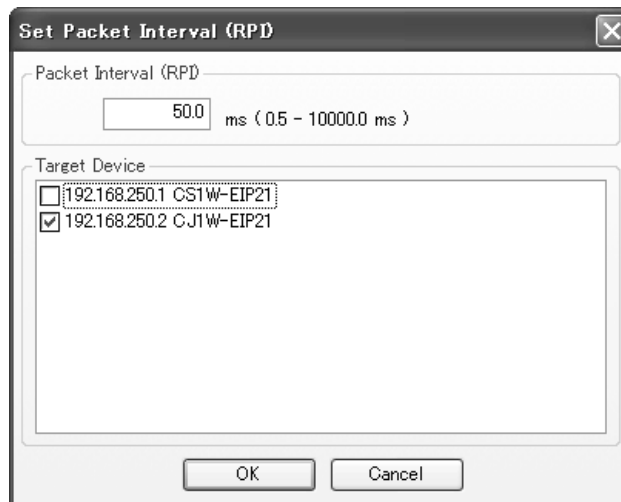

- c. Input a new RPI value, and click the **OK** Button.

**Method 3: Changing a Particular Connection's RPI Setting**

The usage of capacity can be adjusted by individually changing the packet intervals (RPI) setting for a particular connection. In this case, the usage of capacity will also change for the device that is the target device of the connection which was adjusted.



- a. Click the **Close** Button at the bottom of the Usage of Device Bandwidth Dialog Box.
- b. Double-click the device that is set as the originator of the desired connection. The Edit Device Parameters Dialog Box will be displayed.

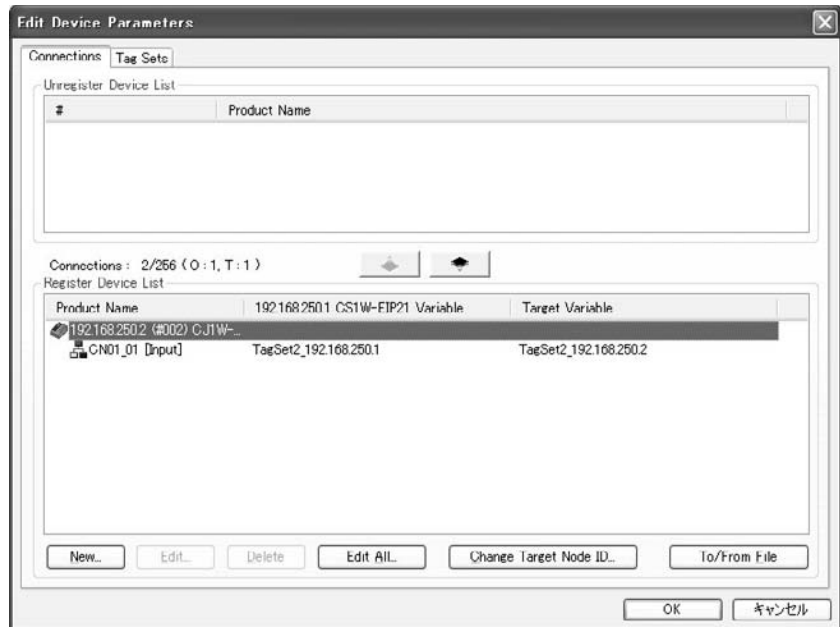

- c. In the Register Device List, select the connection for which you want to change the RPI, and click the **Edit** Button.

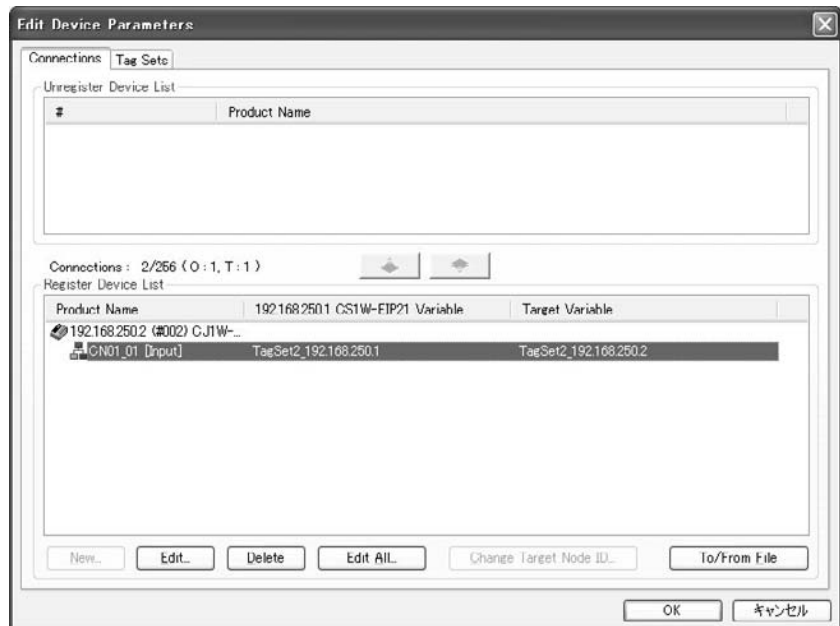

- d. The device's Edit Connections Dialog Box will be displayed. Input a new RPI value, and click the **OK** Button.

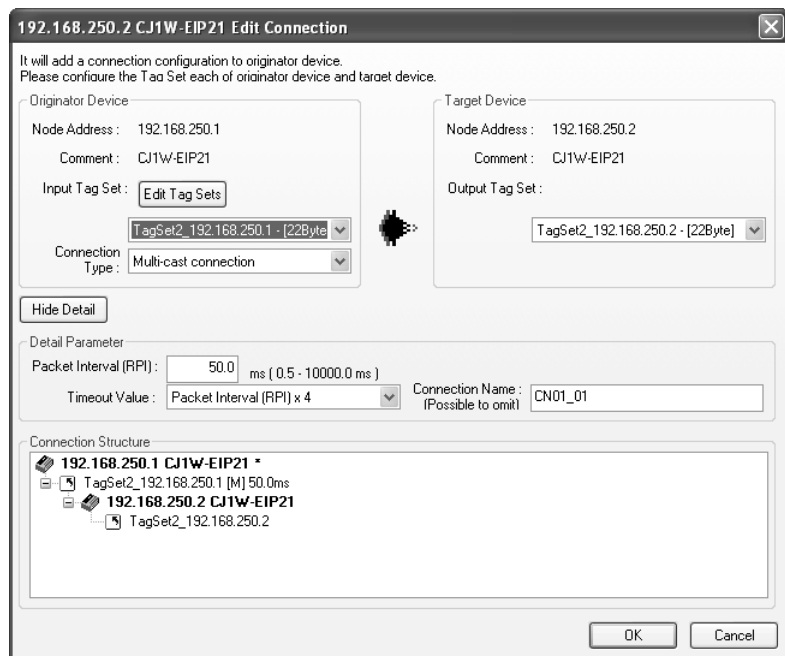

4. If the usage of capacity cannot be adjusted to the desired level when the setting described above has been performed, reconsider the network configuration considering the following points. Refer to *10-2-3 Adjusting Device Bandwidth Usage*.
  - Reduce the number of nodes and number of connections.
  - Split the network.
5. Check the bandwidth usage again.
 

If the connection settings have been changed, click the **Detail** Button in the Usage of Device Bandwidth Area at the bottom of the Network Configuration Window and check bandwidth usage according to the instructions in *10-2-1 Checking Bandwidth Usage for Tag Data Links*. It is particularly important to check the usage of capacity when an individual connection's RPI setting was changed without using the **Set Packet Interval (RPI)** Button at the bottom of the Usage of Device Bandwidth Dialog Box.
6. Run user tests to verify that there are no problems with the new settings.

## 10-2-5 RPI Setting Examples

The following examples explain how to calculate the packet intervals (RPI) in the following network configuration.

**Example Conditions**

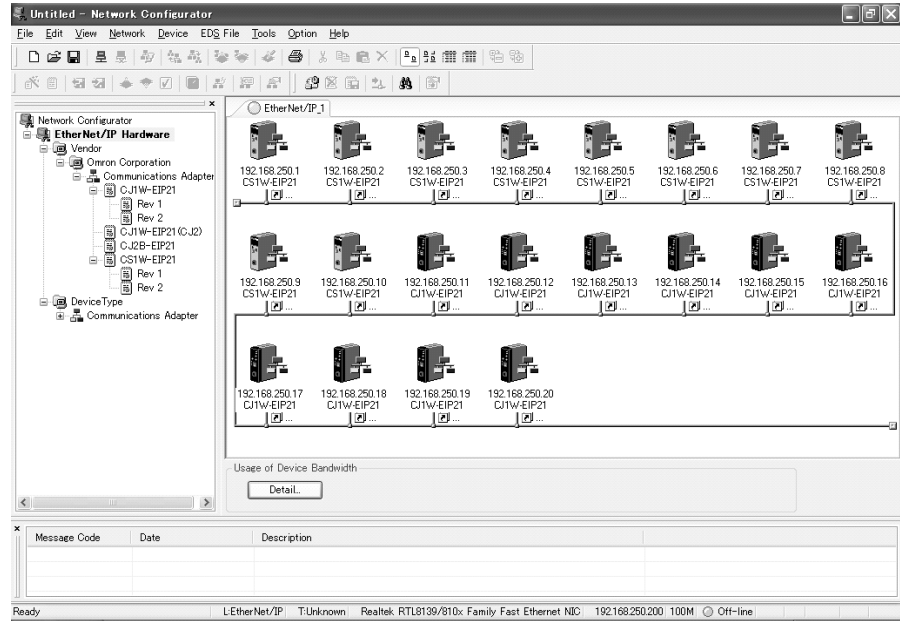

**Connections**

In this example, there are 10 CS1W-EIP21 Units and 10 CJ1W-EIP21 Units for a total of 20 devices connected in the network. Each device has one 100-word tag for transmission and nineteen 100-word tags for reception, so that the Units exchange data mutually.

By default, the packet intervals (RPI) are set to 10 ms for all of the connections. The devices' IP addresses range from 192.168.250.1 to 192.168.250.20.

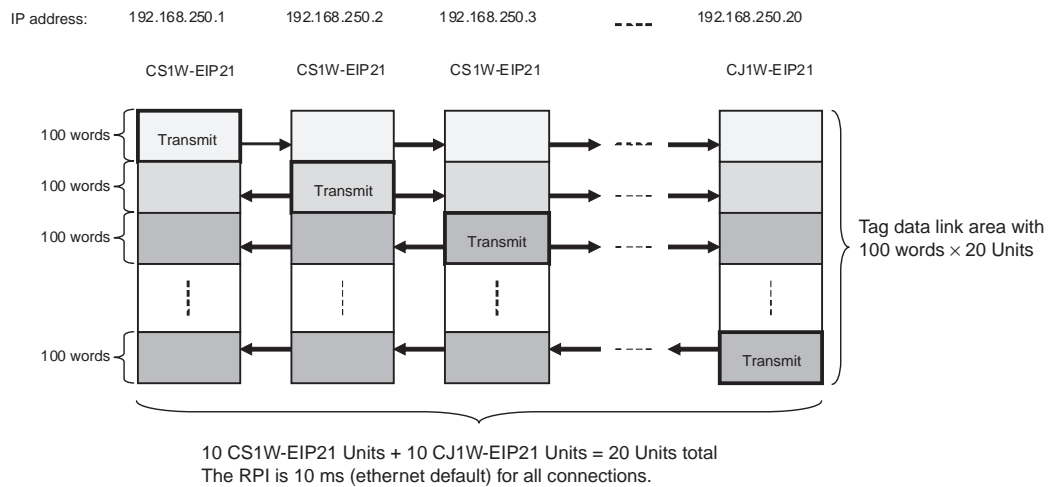

**Checking the Device Bandwidth Usage**

When the **Detail** Button is clicked in the Usage of Device Bandwidth Area, it is apparent that the percentage of the allowed tag data link bandwidth being used by each device's tag data link (Usage of Capacity) is 39.67%, as shown in the following dialog box.

#	Comment	Usage of Capac...	Mbit/s (without ...	Usage of IP mult...
192.168.250.1	CS1W-EIP21	39.67 (39.67) %	4.837 (4.837) Mbi...	1
192.168.250.2	CS1W-EIP21	39.67 (39.67) %	4.837 (4.837) Mbi...	1
192.168.250.3	CS1W-EIP21	39.67 (39.67) %	4.837 (4.837) Mbi...	1
192.168.250.4	CS1W-EIP21	39.67 (39.67) %	4.837 (4.837) Mbi...	1
192.168.250.5	CS1W-EIP21	39.67 (39.67) %	4.837 (4.837) Mbi...	1
192.168.250.6	CS1W-EIP21	39.67 (39.67) %	4.837 (4.837) Mbi...	1
192.168.250.7	CS1W-EIP21	39.67 (39.67) %	4.837 (4.837) Mbi...	1
192.168.250.8	CS1W-EIP21	39.67 (39.67) %	4.837 (4.837) Mbi...	1
192.168.250.9	CS1W-EIP21	39.67 (39.67) %	4.837 (4.837) Mbi...	1
192.168.250.10	CS1W-EIP21	39.67 (39.67) %	4.837 (4.837) Mbi...	1
192.168.250.11	CJ1W-EIP21	39.67 (39.67) %	4.837 (4.837) Mbi...	1
192.168.250.12	CJ1W-EIP21	39.67 (39.67) %	4.837 (4.837) Mbi...	1
192.168.250.13	CJ1W-EIP21	39.67 (39.67) %	4.837 (4.837) Mbi...	1
192.168.250.14	CJ1W-EIP21	39.67 (39.67) %	4.837 (4.837) Mbi...	1
192.168.250.15	CJ1W-EIP21	39.67 (39.67) %	4.837 (4.837) Mbi...	1
192.168.250.16	CJ1W-EIP21	39.67 (39.67) %	4.837 (4.837) Mbi...	1
192.168.250.17	CJ1W-EIP21	39.67 (39.67) %	4.837 (4.837) Mbi...	1
192.168.250.18	CJ1W-EIP21	39.67 (39.67) %	4.837 (4.837) Mbi...	1
192.168.250.19	CJ1W-EIP21	39.67 (39.67) %	4.837 (4.837) Mbi...	1
192.168.250.20	CJ1W-EIP21	39.67 (39.67) %	4.837 (4.837) Mbi...	1

Set Packet Interval (RPI) ... Total usage of IP multicast addresses : 20 Network Total of Max. Mbit/s : 7.190Mbit/s Close

**Changing the Settings**

**Method 1: Same Packet Interval Setting for All Connections**

The percentage of the allowed tag data link bandwidth being used (Usage of Capacity) was 39.67% with the RPI set to 10.0 ms for all of the connections, so the RPI will be set to 5.0 ms, with a target of 80% or less of the allowable bandwidth.

Click the **Set Packet Interval (RPI)** Button at the bottom of the Usage of Device Bandwidth Dialog Box. The Set Packet Interval (RPI) Dialog Box will be displayed. Input 5.0 ms as the new RPI value, and click the **OK** Button.

Packet Interval (RPI)

5 ms ( 0.5 - 10000.0 ms )

Target Device

<input checked="" type="checkbox"/> 192.168.250.1 CS1W-EIP21	<input checked="" type="checkbox"/> 192.168.250.9 CS1W-EIP21	<input checked="" type="checkbox"/> 19
<input checked="" type="checkbox"/> 192.168.250.2 CS1W-EIP21	<input checked="" type="checkbox"/> 192.168.250.10 CS1W-EIP21	<input checked="" type="checkbox"/> 19
<input checked="" type="checkbox"/> 192.168.250.3 CS1W-EIP21	<input checked="" type="checkbox"/> 192.168.250.11 C.J1W-EIP21	<input checked="" type="checkbox"/> 19
<input checked="" type="checkbox"/> 192.168.250.4 CS1W-EIP21	<input checked="" type="checkbox"/> 192.168.250.12 C.J1W-EIP21	<input checked="" type="checkbox"/> 19
<input checked="" type="checkbox"/> 192.168.250.5 CS1W-EIP21	<input checked="" type="checkbox"/> 192.168.250.13 C.J1W-EIP21	
<input checked="" type="checkbox"/> 192.168.250.6 CS1W-EIP21	<input checked="" type="checkbox"/> 192.168.250.14 C.J1W-EIP21	
<input checked="" type="checkbox"/> 192.168.250.7 CS1W-EIP21	<input checked="" type="checkbox"/> 192.168.250.15 C.J1W-EIP21	
<input checked="" type="checkbox"/> 192.168.250.8 CS1W-EIP21	<input checked="" type="checkbox"/> 192.168.250.16 C.J1W-EIP21	

OK Cancel

If the packet interval for all connections has been set to the same setting, the dialog box will show that the usage of capacity for the tag data link's allowable communications bandwidth is 73.00% and the fastest set value is 5.0 ms.

#	Comment	Usage of Capac...	Mbit/s (without ...	Usage of IP mult...
192.168.250.1	CS1W-EIP21	73.00 (73.00) %	9.413 (9.413) Mbi...	1
192.168.250.2	CS1W-EIP21	73.00 (73.00) %	9.413 (9.413) Mbi...	1
192.168.250.3	CS1W-EIP21	73.00 (73.00) %	9.413 (9.413) Mbi...	1
192.168.250.4	CS1W-EIP21	73.00 (73.00) %	9.413 (9.413) Mbi...	1
192.168.250.5	CS1W-EIP21	73.00 (73.00) %	9.413 (9.413) Mbi...	1
192.168.250.6	CS1W-EIP21	73.00 (73.00) %	9.413 (9.413) Mbi...	1
192.168.250.7	CS1W-EIP21	73.00 (73.00) %	9.413 (9.413) Mbi...	1
192.168.250.8	CS1W-EIP21	73.00 (73.00) %	9.413 (9.413) Mbi...	1
192.168.250.9	CS1W-EIP21	73.00 (73.00) %	9.413 (9.413) Mbi...	1
192.168.250.10	CS1W-EIP21	73.00 (73.00) %	9.413 (9.413) Mbi...	1
192.168.250.11	CJ1W-EIP21	73.00 (73.00) %	9.413 (9.413) Mbi...	1
192.168.250.12	CJ1W-EIP21	73.00 (73.00) %	9.413 (9.413) Mbi...	1
192.168.250.13	CJ1W-EIP21	73.00 (73.00) %	9.413 (9.413) Mbi...	1
192.168.250.14	CJ1W-EIP21	73.00 (73.00) %	9.413 (9.413) Mbi...	1
192.168.250.15	CJ1W-EIP21	73.00 (73.00) %	9.413 (9.413) Mbi...	1
192.168.250.16	CJ1W-EIP21	73.00 (73.00) %	9.413 (9.413) Mbi...	1
192.168.250.17	CJ1W-EIP21	73.00 (73.00) %	9.413 (9.413) Mbi...	1
192.168.250.18	CJ1W-EIP21	73.00 (73.00) %	9.413 (9.413) Mbi...	1
192.168.250.19	CJ1W-EIP21	73.00 (73.00) %	9.413 (9.413) Mbi...	1
192.168.250.20	CJ1W-EIP21	73.00 (73.00) %	9.413 (9.413) Mbi...	1

Set Packet Interval (RPI)... Total usage of IP multicast addresses : 20 Network Total of Max. Mbit/s : 11.766Mbit/s Close

**Method 2: Changing the Packet Interval (RPI) of Only Specific Devices**

In this example, we want faster tag data links for devices 192.168.250.1 and 192.168.250.10 only. Click the **Set Packet Interval (RPI)** Button at the bottom of the Usage of Device Bandwidth Dialog Box to display the Set Packet Interval (RPI) Dialog Box.

In the Target Device Area, deselect all devices other than 192.168.250.1 and 192.168.250.10 by removing the corresponding check marks. Input 5.0 ms as the new RPI value, and click the **OK** Button.

Packet Interval (RPI): 5 ms ( 0.5 - 10000.0 ms )

Target Device

<input checked="" type="checkbox"/> 192.168.250.1 CS1W-EIP21	<input type="checkbox"/> 192.168.250.9 CS1W-EIP21	<input type="checkbox"/> 19
<input type="checkbox"/> 192.168.250.2 CS1W-EIP21	<input checked="" type="checkbox"/> 192.168.250.10 CS1W-EIP21	<input type="checkbox"/> 19
<input type="checkbox"/> 192.168.250.3 CS1W-EIP21	<input type="checkbox"/> 192.168.250.11 CJ1W-EIP21	<input type="checkbox"/> 19
<input type="checkbox"/> 192.168.250.4 CS1W-EIP21	<input type="checkbox"/> 192.168.250.12 CJ1W-EIP21	<input type="checkbox"/> 19
<input type="checkbox"/> 192.168.250.5 CS1W-EIP21	<input type="checkbox"/> 192.168.250.13 CJ1W-EIP21	
<input type="checkbox"/> 192.168.250.6 CS1W-EIP21	<input type="checkbox"/> 192.168.250.14 CJ1W-EIP21	
<input type="checkbox"/> 192.168.250.7 CS1W-EIP21	<input type="checkbox"/> 192.168.250.15 CJ1W-EIP21	
<input type="checkbox"/> 192.168.250.8 CS1W-EIP21	<input type="checkbox"/> 192.168.250.16 CJ1W-EIP21	

OK Cancel

The percentage of the allowed tag data link bandwidth being used (Usage of Capacity) increases to 74.67% for devices 192.168.250.1 and 192.168.250.10, which indicates that the RPI is set to a higher speed for these devices' connections.

The Usage of Capacity values also indicate that the Usage of Capacity has increased (from 39.67% to 43.00%) for all of the other devices, which connect with devices 192.168.250.1 and 192.168.250.10.

#	Comment	Usage of Capac...	Mbit/s (without ...	Usage of IP mult...
192.168.250.1	CS1W-EIP21	74.67 (106.33) %	9.642 (13.989) M...	2
192.168.250.2	CS1W-EIP21	43.00 (106.33) %	5.295 (13.989) M...	2
192.168.250.3	CS1W-EIP21	43.00 (106.33) %	5.295 (13.989) M...	2
192.168.250.4	CS1W-EIP21	43.00 (106.33) %	5.295 (13.989) M...	2
192.168.250.5	CS1W-EIP21	43.00 (106.33) %	5.295 (13.989) M...	2
192.168.250.6	CS1W-EIP21	43.00 (106.33) %	5.295 (13.989) M...	2
192.168.250.7	CS1W-EIP21	43.00 (106.33) %	5.295 (13.989) M...	2
192.168.250.8	CS1W-EIP21	43.00 (106.33) %	5.295 (13.989) M...	2
192.168.250.9	CS1W-EIP21	43.00 (106.33) %	5.295 (13.989) M...	2
192.168.250.10	CS1W-EIP21	74.67 (106.33) %	9.642 (13.989) M...	2
192.168.250.11	CJ1W-EIP21	43.00 (106.33) %	5.295 (13.989) M...	2
192.168.250.12	CJ1W-EIP21	43.00 (106.33) %	5.295 (13.989) M...	2
192.168.250.13	CJ1W-EIP21	43.00 (106.33) %	5.295 (13.989) M...	2
192.168.250.14	CJ1W-EIP21	43.00 (106.33) %	5.295 (13.989) M...	2
192.168.250.15	CJ1W-EIP21	43.00 (106.33) %	5.295 (13.989) M...	2
192.168.250.16	CJ1W-EIP21	43.00 (106.33) %	5.295 (13.989) M...	2
192.168.250.17	CJ1W-EIP21	43.00 (106.33) %	5.295 (13.989) M...	2
192.168.250.18	CJ1W-EIP21	43.00 (106.33) %	5.295 (13.989) M...	2
192.168.250.19	CJ1W-EIP21	43.00 (106.33) %	5.295 (13.989) M...	2
192.168.250.20	CJ1W-EIP21	43.00 (106.33) %	5.295 (13.989) M...	2

Set Packet Interval (RPI) ... Total usage of IP multicast addresses : 40 Network Total of Max. Mbit/s : 16.342Mbit/s Close

In this case, if there is no multicast filter, the value becomes 106.33%. If there is no multicast filter for a switching hub, communications errors may occur depending on the communications load of the EtherNet/IP Unit or built-in EtherNet/IP Unit port.

### Method 3: Changing the Packet Interval (RPI) of Only Specific Connections

In this example, we want a faster tag data links for just a particular connection of device 192.168.250.1.

Double-click device 192.168.250.1 in the Network Configuration Window.

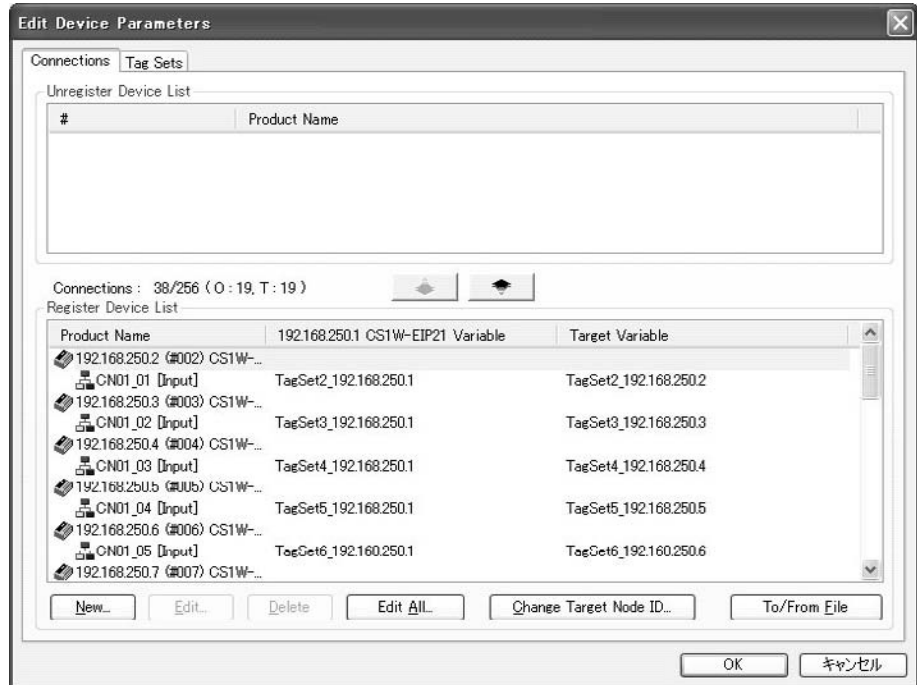

Information about the connection with device 192.168.250.20 is registered in the Register Device List. Double-click this connection to edit the settings.

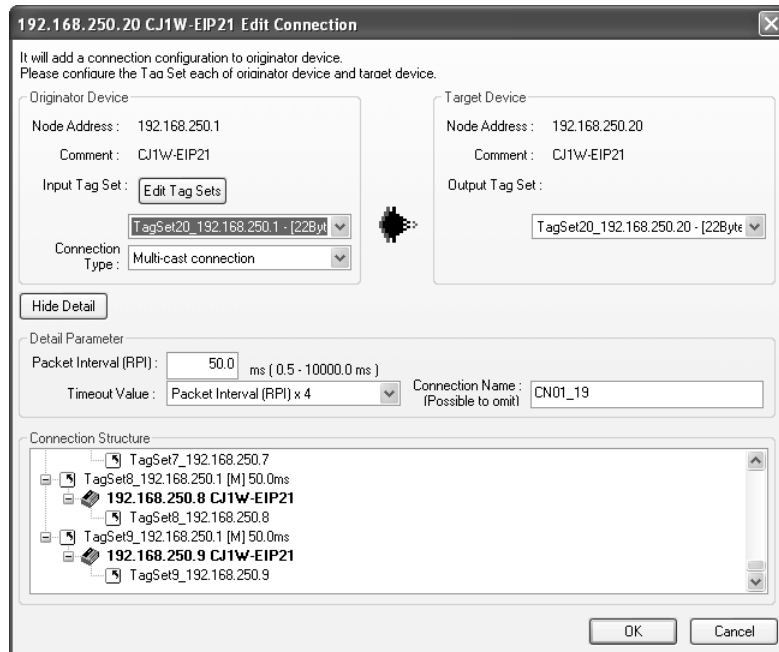

In the Edit Connection Dialog Box, input 1.0 ms as the new RPI value, and click the **OK** Button. The tag data link bandwidth being used by device 192.168.250.1 (Usage of Capacity) increases to 54.67%, which indicates that a RPI is set to a higher speed for this device.

#	Comment	Usage of Capac...	Mbit/s (without ...	Usage of IP mult...
192.168.250.1	CS1W-EIP21	54.67 (56.33) %	6.897 (7.125) Mbi...	1
192.168.250.2	CS1W-EIP21	39.67 (56.33) %	4.837 (7.125) Mbi...	1
192.168.250.3	CS1W-EIP21	39.67 (56.33) %	4.837 (7.125) Mbi...	1
192.168.250.4	CS1W-EIP21	39.67 (56.33) %	4.837 (7.125) Mbi...	1
192.168.250.5	CS1W-EIP21	39.67 (56.33) %	4.837 (7.125) Mbi...	1
192.168.250.6	CS1W-EIP21	39.67 (56.33) %	4.837 (7.125) Mbi...	1
192.168.250.7	CS1W-EIP21	39.67 (56.33) %	4.837 (7.125) Mbi...	1
192.168.250.8	CS1W-EIP21	39.67 (56.33) %	4.837 (7.125) Mbi...	1
192.168.250.9	CS1W-EIP21	39.67 (56.33) %	4.837 (7.125) Mbi...	1
192.168.250.10	CS1W-EIP21	39.67 (56.33) %	4.837 (7.125) Mbi...	1
192.168.250.11	CJ1W-EIP21	39.67 (56.33) %	4.837 (7.125) Mbi...	1
192.168.250.12	CJ1W-EIP21	39.67 (56.33) %	4.837 (7.125) Mbi...	1
192.168.250.13	CJ1W-EIP21	39.67 (56.33) %	4.837 (7.125) Mbi...	1
192.168.250.14	CJ1W-EIP21	39.67 (56.33) %	4.837 (7.125) Mbi...	1
192.168.250.15	CJ1W-EIP21	39.67 (56.33) %	4.837 (7.125) Mbi...	1
192.168.250.16	CJ1W-EIP21	39.67 (56.33) %	4.837 (7.125) Mbi...	1
192.168.250.17	CJ1W-EIP21	39.67 (56.33) %	4.837 (7.125) Mbi...	1
192.168.250.18	CJ1W-EIP21	39.67 (56.33) %	4.837 (7.125) Mbi...	1
192.168.250.19	CJ1W-EIP21	39.67 (56.33) %	4.837 (7.125) Mbi...	1
192.168.250.20	CJ1W-EIP21	56.33 (56.33) %	7.125 (7.125) Mbi...	2

Set Packet Interval (RPI) ... Total usage of IP multicast addresses : 21 Network Total of Max. Mbit/s : 9.478Mbit/s Close

In this case, the tag data link bandwidth being used by device 192.168.250.20 (Usage of Capacity) also increases (from 39.67% to 56.33%).



### 10-3 I/O Response Time in Tag Data Links

**Note** This section describes the data processing time for an EtherNet/IP Unit or a built-in EtherNet/IP port on a CJ2H-CPU6□-EIP CPU Unit. The data processing time for a built-in EtherNet/IP port on the CJ2M-CPU3□ CPU Unit is different. For details, refer to *10-4 Tag Data Link Performance for CJ2M Built-in EtherNet/IP Ports*.

#### 10-3-1 Timing of Data Transmissions

The following diagram shows the timing of tag data link transmissions between the EtherNet/IP Unit or CJ2H built-in port and the CPU Unit.

The data transmission is processed during the I/O refresh period. Send data is processed with transmission at regular intervals, and received data is processed together with the send data when new data has been received from other nodes. The following diagram shows the timing of data transmissions.

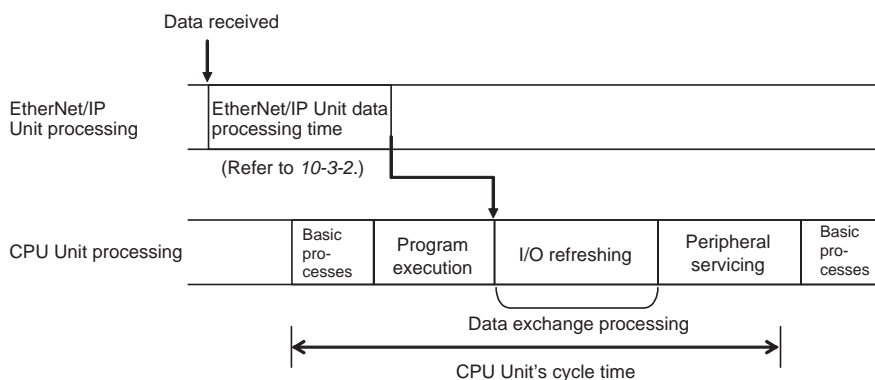

If there is an interrupt for data transmission processing, the CPU Unit's cycle time is extended by that interrupt processing time. Refer to *10-3-2 EtherNet/IP Unit or CJ2H Built-in Port Data Processing Time* for details.

#### 10-3-2 EtherNet/IP Unit or CJ2H Built-in Port Data Processing Time

The following formula approximates the time required for the EtherNet/IP Unit or CJ2H built-in port to process data transmissions with the CPU Unit (i.e., the data processing time).

<b>Approximation of the data processing time for an EtherNet/IP Unit or CJ2H Built-in Port</b>
$(0.0008 \times \text{Number of data transmission words}) + 1.0 \text{ ms}$

The maximum number of tag data link words that can be transferred by one EtherNet/IP Unit or CJ2H built-in port is 184,832 words. However, if the number of tag data link words exceeds the number of words that can be exchanged with the CPU Unit at one time, the data will be divided and transferred in multiple data exchanges. The following table shows the number of words that each CPU Unit can exchange at one time.

CPU Unit	Number of words per data transmission
CS/CJ Series	Output/Send: About 7,405 words max. (If there are more words, the data will be divided.) Input/Receive: About 7,405 words max. (If there are more words, the data will be divided.) <b>Note</b> The total amount of send data and receive data that can be exchanged at one time is about 14,810 words maximum.
SYSMAC CJ2 Series	Output/send: About 6,432 words max. (If there are more words, the data will be separated into multiple transmissions.) Input/receive: About 6,432 words max. (If there are more words, the data will be separated into multiple transmissions.) <b>Note</b> The total amount of send data and receive data that can be transferred at one time is about 12,864 words maximum.

The number of data exchanges may double as given in the following table according to the relation with the CPU Unit's cycle time and the data processing time of the EtherNet/IP Unit or CJ2H built-in port.

Condition	Number of data transmissions
CPU Unit's cycle time > EtherNet/IP Unit or CJ2H built-in port data processing time	Number of data transmissions based on the data size
CPU Unit's cycle time ≤ EtherNet/IP Unit or CJ2H built-in port data processing time	Number of data transmissions × 2 based on the data size

- Note**
- (1) With CS/CJ-series PLCs, consecutive data area words specified in the tag set will be transferred together if possible. Up to 19 send data blocks can be processed in one data transmission; up to 20 receive data blocks can be processed in one data transmission. If there are more blocks, the data will be divided and transferred in separate data transmissions.
  - (2) The preceding data processing time approximation is the standard formula when a higher priority processing event does not occur in peripheral servicing. For example, if an instruction such as SEND, RECV, or FAL is executed, the instruction's processing will have higher priority, so the data processing time may be longer.

### 10-3-3 Effect on the CPU Unit's Cycle Time

The CPU Unit's cycle time is affected when the EtherNet/IP Unit or CJ2H built-in port refreshes tag data and status data with the CPU Unit. This effect depends on the size of the tag data links, and can be approximated with the values in the following table. When there are multiple EtherNet/IP Units or CJ2H built-in ports, the effect is cumulative.

CPU Unit	Effect of EtherNet/IP Unit or CJ2H built-in port only	Total effect when tag data links are being used
CJ2H	CPU Rack: 0.1 ms Expansion Rack: 0.13 ms	CPU Rack: Value from left column + 0.1 ms + No. of words transferred × 0.33 μs (See note 2.) Expansion Rack: Value from left column + 0.1 ms + No. of words transferred × 0.45 μs
CJ2M	CPU Rack: 0.14 ms Expansion Rack: 0.16 ms	CPU Rack: Value from left column + 0.02 ms + No. of words transferred × 0.78 μs Expansion Rack: Value from left column + 0.02 ms + No. of words transferred × 0.92 μs
CJ1	0.25 ms	0.25 ms + 1.5 ms + (Number of words × 1 μs)
CJ1M	0.17 ms	0.17 ms + 0.1 ms + (Number of words × 0.7 μs)
CJ1-H	0.1 ms	0.1 ms + 0.1 ms + (Number of words × 0.7 μs)
CS1	0.2 ms	0.2 ms + 1.5 ms + (Number of words × 1 μs)
CS1-H	0.1 ms	0.1 ms + 0.1 ms + (Number of words × 0.7 μs)
Long-distance Rack	0.2 ms × Coefficient 2	(0.2 ms × Coefficient 2) + 1.5 ms + (Number of words × 1 μs × Coefficient 3)

**Note** (1) When one of the listed CPU Bus Units is mounted in a CS-series Long-distance Rack, the I/O refreshing time is extended by the distance to the Rack in which the Unit is mounted, regardless of the model of the CPU Unit. The following graph shows the coefficients (2 and 3) required to calculate this effect.

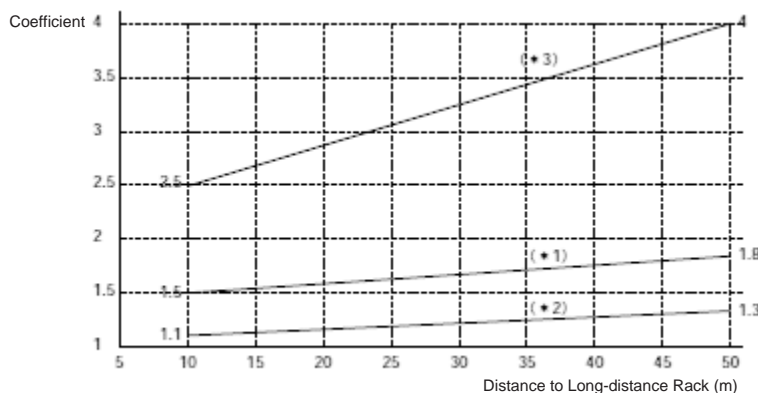

(2) The additional time for CJ2H CPU Units with unit version 1.1 or later will be as follows if high-speed interrupts are enabled.

$$0.1 \text{ ms} + \text{Number of words transferred} \times 0.87 \mu\text{s}$$

### 10-3-4 Tag Data Link I/O Response Time Calculation Example

When using the tag data link functions of the EtherNet/IP Unit or CJ2H built-in port, there is a time lag between the point when the data link area's data changes due to an input at a node and the point when the change is output at another node's data link area. This time lag is called the tag data link I/O response time.

This example shows how to calculate the minimum and maximum I/O response times in the following configuration for connection 1 opened between node 1 and node 2.

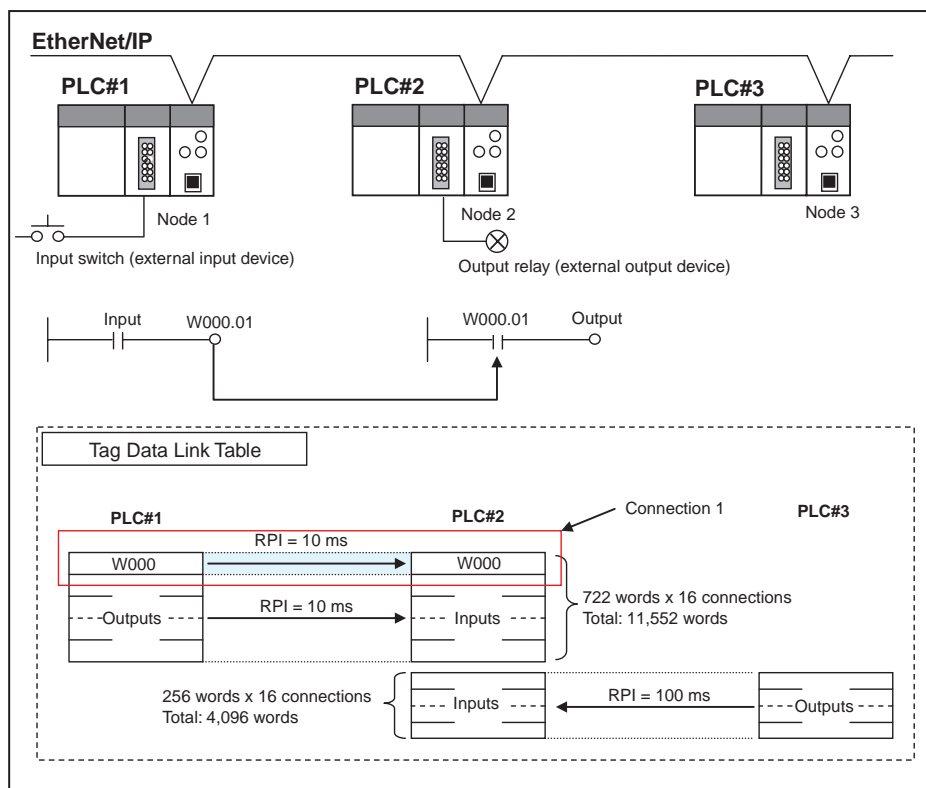

The following table gives the items required to find the I/O response time and values used in calculations for this system configuration.

Item	Value used in calculation example	
	PLC#1	PLC#2
External I/O device delay time	Input device delay: 1.5 ms	Output device delay: 2.0 ms
Cable length	50 m	
CPU Unit model	CJ2H CPU Unit	CJ2H CPU Unit
RPI	10 msec	---
Number of receive connections	0	32
CPU Unit cycle time	10 msec	15 msec
Total number tag data link words	Number of send words	11,552
	Number of receive words	None
		15,648

### Maximum Tag Data Link I/O Response Time

You can find the maximum I/O response time from the total of (1) to (6) in the following figure.

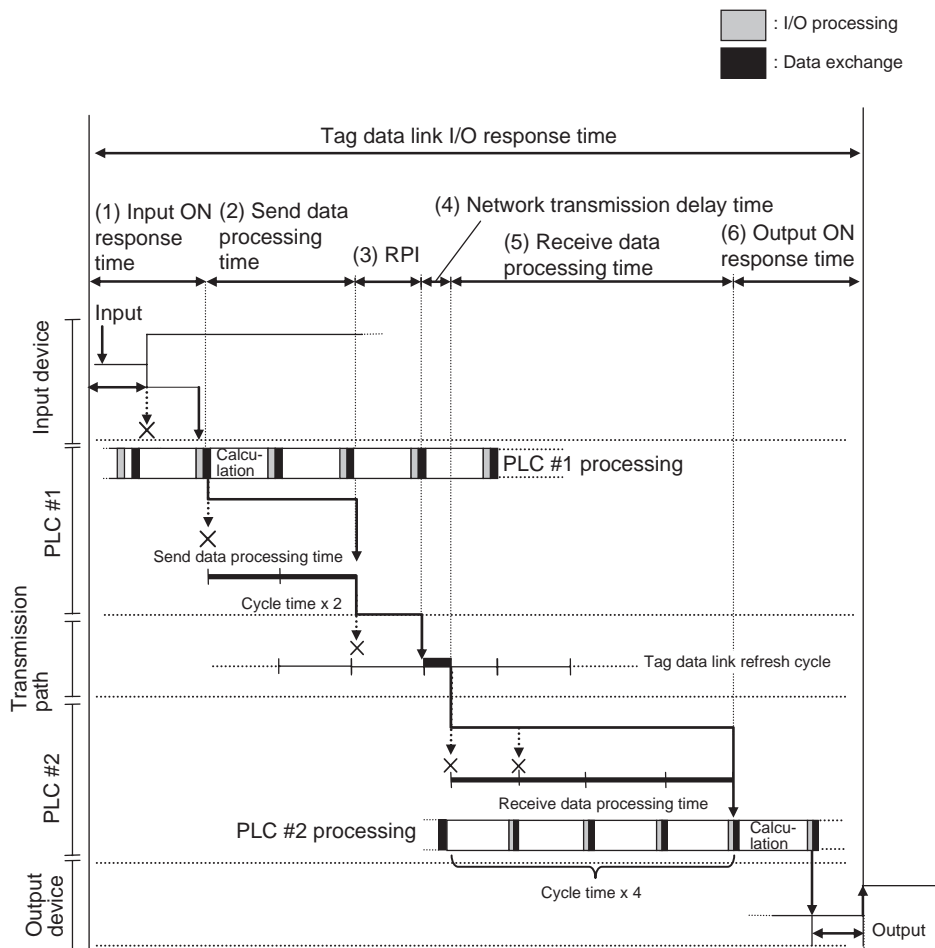

**(1) Node 1 (PLC #1) Input ON Response Time**

This is the delay time for the external input device from when the input occurs until the switch actually turns ON and the time until the input data is stored in the memory area of the CPU Unit for PLC #1. In this system, the input switch delay time is 1.5 ms. Also, one CPU cycle time is required until the data is stored in the memory area of the CPU Unit. Therefore, the input ON response time is 1.5 ms + 10 ms, or 11.5 ms.

**(2) Node 1 (PLC #1) Send Data Processing Time**

This is the time until memory data in the CPU Unit is transferred to the EtherNet/IP Unit. If the amount of data that can be processed in one data transmission with the CPU Unit is exceeded, data transmission will be performed over multiple cycles of the CPU Unit, and so time is calculated for the number of transmissions times the CPU Unit cycle times. The following table gives the send data processing times and breakdown for node 1 (PLC #1) in this system configuration. Refer to 10-3-2 EtherNet/IP Unit or CJ2H Built-in Port Data Processing Time for details on the calculation formula for each item.

Item	Calculation formula	Time
① CPU Unit cycle time for PLC #1		10 m sec
② Number of transmissions based on the data size	Number of data transmission words (11,552 words) ÷ 6,432 words (using a CJ2 CPU Unit)	2
③ EtherNet/IP Unit data processing time	0.0008 × 6,432 + 1.0 (Maximum number of transmission words per cycle)	6.15 m sec

Item	Calculation formula	Time
④ Number of data transmissions	① 10 m sec > ③ 6.15 m sec To meet the conditions, the number of transmissions is the same as ②.	2
Total: (2) Send data processing time	CPU Unit cycle time of ① PLC #1 × ④ Number of data transmissions	20 m sec

### (3) Packet Interval (RPI)

This is the communications refresh cycle set for each connection using the Network Configurator. In this system, it is the refresh cycle for connection 1 (10 ms), which includes W000.01.

### (4) Network Transmission Delay Time

This is the total of the send processing delay, receive processing delay, switching hub delay, and cable delay. Refer to *10-1-3 Network Transmission Delay Time* for details on the calculation formula for network delay time. In this system, it is 5.2 ms.

Delay item	Calculation formula	Max. delay time
① Send processing delay	10 m sec × (15-10 msec/100)%	1.49 msec
② Cable delay	545 nsec + 50 m/100	272.5 nsec
③ Switching hub delay	2 msec + Approx. 0.7 msec	2.7 msec
④ Receive processing delay	1 + (0 connection × 0.043)	1.0 msec
Total: (4) Network Transmission Delay Time	① + ② + ③ + ④	5.2 msec

### (5) Node 2 (PLC #2) Receive Data Processing Time

This is the time to transfer the data received by the EtherNet/IP Unit or CJ2H built-in port to the memory area in the CPU Unit. Receive data is transferred in the order that it is received, but if the amount of data that can be processed in one transmission is exceeded, multiple cycles are required to transfer the data. Also, data transmission is performed only once per CPU Unit cycle. Therefore, if data transfer has ended in the cycle in which data is received, the start of transmission for received data will be delayed by one CPU Unit cycle time.

In this system configuration, data transfer is performed a maximum of three times based on the data size of node 2 (PLC #2) to transfer received data for node 1 (PLC #1) and node address 3 (PLC #3). Also, the cycle time of PLC #2 is 15 ms, the effect on the CPU Unit cycle time is 2.3 ms, and the data processing time for the EtherNet/IP Unit or CJ2H built-in port is 6.15 ms. The number of data transmissions is thus calculated as 3. In addition, the number of data transmissions is calculated as a maximum of 4 (3 + 1) because it is necessary to consider a delay of one CPU Unit cycle time in transferring received data.

Item	Calculation formula	Time
① CPU Unit cycle time	---	15 msec
② Number of transmissions based on the data size	Number of data transmission words (15,648 words) ÷ 6,432 words (using a CJ2 CPU Unit)	3
③ EtherNet/IP Unit data processing time	0.0008 × 6,432 + 1.0 (Maximum number of transmission words per cycle)	6.15 msec

Item	Calculation formula	Time
④ Number of data transmissions	① 10 m sec > ③ 6.15 m sec To meet the condition to enable processing in one data transmission, the number of transmissions is the same as ② plus 1. (Delay of one CPU Unit cycle time)	4
Total: (5) Receive data processing time	① Cycle time × ④ Number of data transmissions	60 msec

**(6) Output ON response time**

This is the delay time for the external output device from when the output bit turns ON in the memory of the CPU Unit until the output is actually performed. In this system configuration, the delay time for an output relay is 2.0 ms. Also, one CPU cycle time is required until the data is stored in the memory area of the CPU Unit.

Item	Time
① CPU Unit cycle time of PLC #2	15 msec
② Output relay delay time	2.0 msec
Total: (6) Node 2 (PLC #2) output ON response time	17.0 msec

The maximum tag data link I/O response time for this system configuration found from the total of (1) to (6) is 124 ms.

(1) Node 1 (PLC #1) input ON response time	11.5 msec
(2) Node 1 (PLC #1) send data processing time	20 msec
(3) Packet Interval (RPI)	10 msec
(4) Network Transmission Delay Time	5.5 msec
(5) Node 2 (PLC #2) receive data processing time	60 msec
(6) Output ON response time	17 msec
Maximum I/O response performance (total of (1) to (6))	124 msec

**Note** The I/O response time may be longer due to noise, or other events.

Minimum Tag Data Link I/O Response Time

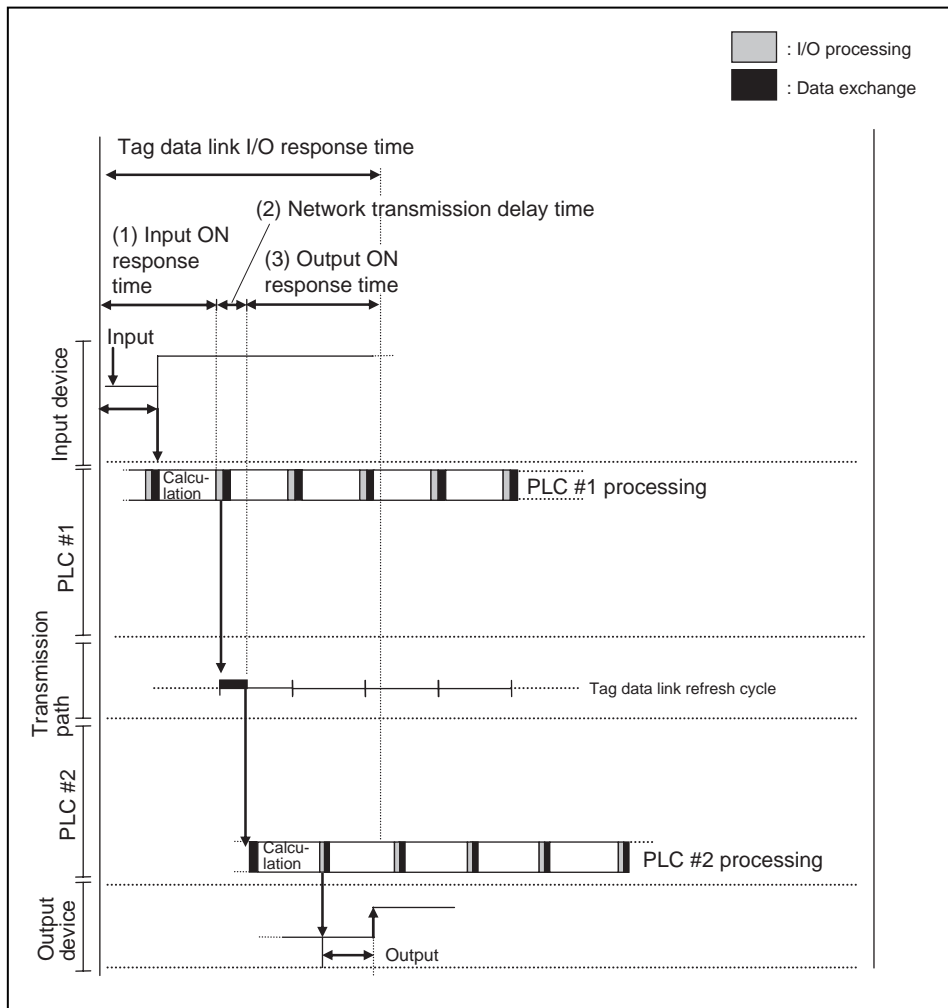

The minimum tag data link I/O response time, which occurs when there are no processing delays, is calculated as follows.

(1) Node 1 (PLC #1) input ON response time	Input switch delay time	1.5 ms
	CPU Unit cycle time of PLC #1	10.0 ms
(2) Transmission time (722 send data words)		0.121 msec
(3) Node 2 (PLC #1) output ON response time	CPU Unit cycle time of PLC #2	15.0 ms
	Output relay delay time	2.0 ms
Total (tag data link I/O response time)		28.6 ms

When the baud rate is 100 Mbps, the transmission time can be calculated with the following equation. If a network delay does not occur, just this transmission time is added.

$$\text{Transmission time} = (\text{Number of send data words} \times 2 + 74) \times 8 \times 0.00001 \text{ ms}$$

**Note** The I/O response time may be longer due to noise, or other events.



## 10-4 Tag Data Link Performance for CJ2M Built-in EtherNet/IP Ports

### 10-4-1 Overview

The built-in EtherNet/IP port on a CJ2M CPU Unit (CJ2M-CPU3□) supports tag data links for up to 32 connections, with a data size of 640 words (20 words for unit version 2.0) per connection. These specifications are different from those of CJ2H built-in ports and EtherNet/IP Units.

A maximum of 640 words of tag data links can be used in communications.

This 640 words is the amount of data that is processed for one data transmissions between the CPU Unit and the CJ2M built-in port.

The tag data link specifications of CJ2M built-in ports are provided in the following table. If these specifications are insufficient for the required system configuration, use a CJ2H built-in port on a CJ2H-CPU6□-EIP CPU Unit or a CJ1W-EIP21 EtherNet/IP Unit.

#### Tag Data Link Specifications for CJ2M Built-in EtherNet/IP Ports

	CJ2M built-in port (CJ2M-CPU3□)	Reference: CJ2H built-in port (CJ2H-CPU6□-EIP)
Number of connections	32	256
Packet interval (RPI)	1 to 10,000 ms (in 0.5-ms units)	0.5 to 10,000 ms (in 0.5-ms units)
Allowed communications bandwidth per Unit (PPS)	3,000 pps	6,000 pps
Number of tags that can be registered	32	256
Tag types	CIO Area, DM Area, EM Area, Holding Area, Work Area, and network symbols	
Number of registrable tag sets	32	256
Number of tags per connection	8 (7 tags when the tag set contains the PLC status)	
Maximum size of 1 tag set	640 words* <sup>1</sup> (The PLC status uses 1 word when the tag set contains the PLC status.)	722 words (The PLC status uses 1 word when the tag set contains the PLC status.)
Maximum data size per connection	640 words* <sup>1</sup>	722 words
Maximum link data size per node (total size of all tags)	640 words	184,832 words
Maximum number of tags that can be refreshed per CPU Unit cycle	Output/Transmission (CPU → EtherNet/IP): 32 Input/Reception (EtherNet/IP → CPU): 32	Output/Transmission (CPU → EtherNet/IP): 256 Input/Reception (EtherNet/IP → CPU): 256
Data that can be refreshed per CPU Unit cycle	Output/Transmission (CPU → EtherNet/IP): 640 words Input/Reception (EtherNet/IP → CPU): 640 words <b>Note</b> The total for output/transmission and input/reception is 640 words.	Output/Transmission (CPU → EtherNet/IP): 6,432 words Input/Reception (EtherNet/IP → CPU): 6,432 words <b>Note</b> The total for output/transmission and input/reception is 12,864 words.

\*1 Unit version 2.0: 20 words maximum.

#### Tag Data Link System Configuration Example

This example configuration is based on the maximum specifications for CJ2M built-in ports where all nodes send and receive data to the other nodes. As shown in the following figure, the send area for each node in a 17-node configuration is 20 words.

For example, node 1 establishes 16 send connections and 16 receive connections to the other 16 nodes, for a total of 32 connections. The data size per connection is 20 words for the send area to the other nodes and 20 words each of the receive areas from the other nodes.

If the same RPI is set for all connections, 12 ms is the lowest setting that can be used.

■ Calculation Example

$$(1,000 \div 12 \text{ [ms] (RPI)} + 1,000 \div 100 \text{ [ms] (heartbeat transmission period)}) \times 32 \text{ (connections)} = 2,987 \text{ pps} < 3,000 \text{ pps}$$

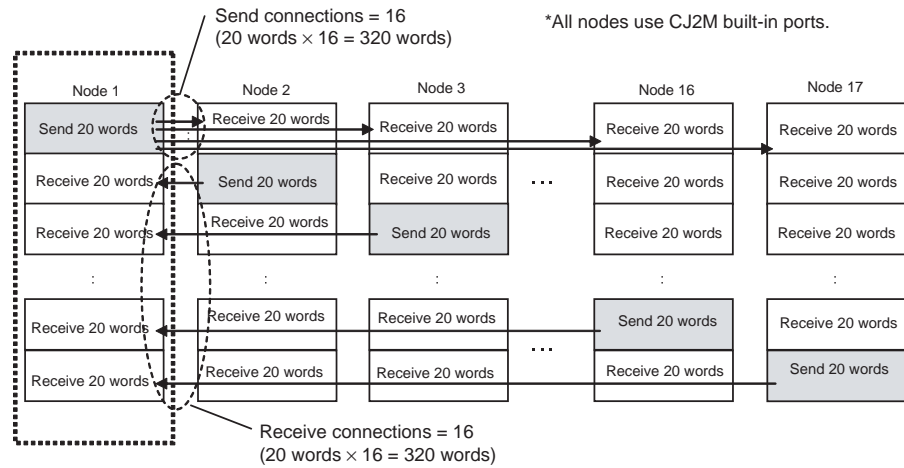

### 10-4-2 Tag Data Link I/O Response Time

With tag data links, if the data in the data link area for a node changes due to an input to that node, a certain amount of time is required for the data in data link area at another node to be updated and output.

The I/O response time for tag data links can be calculated for a CJ2M built-in port in the same way as it can for a CJ2H built-in port (refer to 10-3-4 Tag Data Link I/O Response Time Calculation Example). Here, formulas to calculate guideline I/O response times are provided. (Tag data link delays are ignored because the data link size handled by the built-in CJ2M port is small.)

**Maximum I/O Response Time**

Input ON delay + Cycle time of sending PLC × 2 + RPI + Cycle time of receiving PLC × 2 + Output ON delay

**Minimum I/O Response Time**

Input ON delay + Cycle time of sending PLC + Cycle time of receiving PLC + Output ON delay

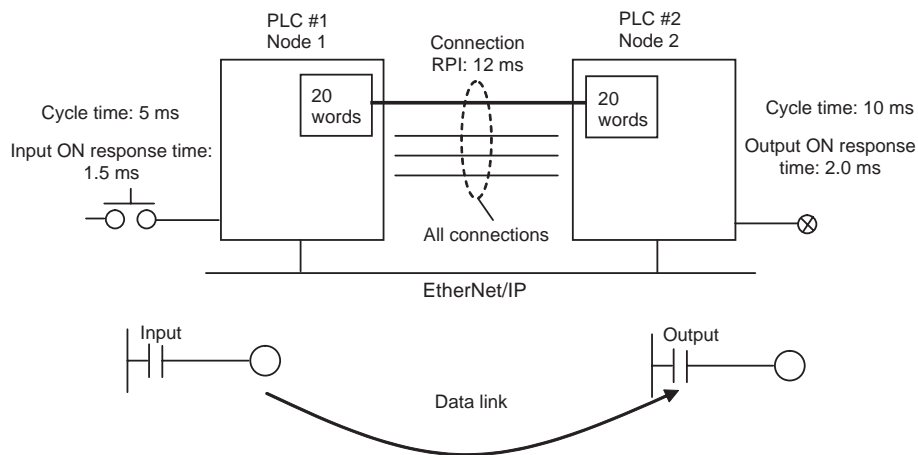

For example, the maximum and minimum I/O response times would be as follows for the above system.

Maximum response time:

$$1.5 \text{ ms} + 5 \text{ ms} \times 2 + 12 \text{ ms} + 10 \text{ ms} \times 2 + 2.0 \text{ ms} = 45.5 \text{ ms}$$

Minimum response time:

$$1.5 \text{ ms} + 5 \text{ ms} + 10 \text{ ms} + 2.0 \text{ ms} = 18.5 \text{ ms}$$

**Note** If the message service is used at the same time on the CJ2M built-in port, the tag data link I/O response time will change.

## 10-5 Message Service Transmission Delay

This section explains the maximum transmission delay that can occur between the execution of a SEND(090), RECV(098), or CMND(490) instruction in the ladder program until completion of the instruction. This delay does not include the time required for the tag data link or the execution time of the ladder program itself.

### 10-5-1 Maximum Transmission Delays (Excluding Delays in the Network)

Use the following equation to calculate the maximum transmission delay that can occur between the execution of a SEND(090) or RECV(098) instruction in the ladder program until completion of the instruction.

#### SEND(090) Instruction

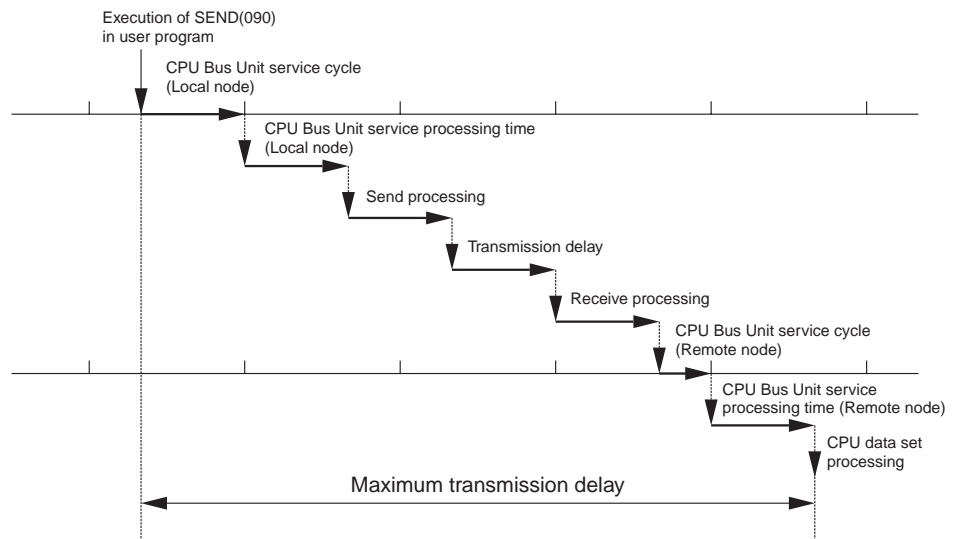

Maximum transmission delay =

- + CPU Bus Unit service cycle (local node)
- + CPU Bus Unit service processing time (local node)
- + Send processing
- + Transmission delay
- + Receive processing
- + CPU Bus Unit service cycle (remote node)
- + CPU Bus Unit service processing time (remote node)

#### CPU Bus Unit Service Cycle (Local Node)

The following table shows the service cycle, which depends on the CPU Unit's CPU processing mode setting.

CPU execution mode	Processing time details
Normal Mode (See note.)	One CPU Unit cycle time
Priority peripheral servicing	
Parallel processing with synchronous memory access	
Parallel processing with asynchronous memory access	0.2 ms + peripheral servicing time (1 ms max. for peripheral servicing of each Special I/O Unit, CPU Bus Unit, peripheral port, RS-232C port, and Inner Board)

**Note** CJ2 CPU Units support only Normal Mode.

For details, refer to the *CPU Unit's Operation Manual*.

**CPU Bus Unit Service Processing Time (Local Node)**

The following table shows the CPU Bus Unit service processing time, which depends on the CPU Unit's CPU processing mode setting.

CPU execution mode	Processing time details
Normal Mode (See note.)	Set peripheral servicing time Default: 4% of CPU Unit cycle time (10% for CJ2 CPU Units)
Priority peripheral servicing	
Parallel processing with synchronous memory access	
Parallel processing with asynchronous memory access	1 ms max.

**Note** CJ2 CPU Units support only Normal Mode.

For details, refer to the *CPU Unit's Operation Manual*.

**Send Processing**

$(\text{Number of words being transferred} \times 0.002) + 0.550 \text{ ms}$

**Transmission Delay**

The transmission delay time depends on the baud rate set for the EtherNet/IP Unit or built-in EtherNet/IP port, as shown in the following table. (There may be additional delays due to the other devices in the network, such as switching hubs.)

Baud rate	Delay time
100Base-TX	$(\text{Number of words being transferred} \times 0.0013) + 0.0118 \text{ ms}$
10Base-T	$(\text{Number of words being transferred} \times 0.0019) + 0.0157 \text{ ms}$

**Receive Processing**

$(\text{Number of words being transferred} \times 0.003) + 0.704 \text{ ms}$

**CPU Bus Unit Service Cycle (Remote Node)**

The following table shows the CPU Bus Unit service cycle, which depends on the CPU Unit's CPU processing mode setting.

CPU execution mode	Processing time details	
Normal Mode (See note.)	One CPU Unit cycle time	
Priority peripheral servicing	EtherNet/IP Unit or built-in EtherNet/IP port is given priority.	Time slice instruction execution time
	EtherNet/IP Unit or built-in EtherNet/IP port is not given priority.	One CPU Unit cycle time
Parallel processing with synchronous memory access	One CPU Unit cycle time	
Parallel processing with asynchronous memory access	0.2 ms + peripheral servicing time (1 ms max. for peripheral servicing of each Special I/O Unit, CPU Bus Unit, peripheral port, RS-232C port, and Inner Board)	

**Note** CJ2 CPU Units support only Normal Mode.

For details, refer to the *CPU Unit's Operation Manual*.

**CPU Bus Unit Service Processing Time (Remote Node)**

The following table shows the CPU Bus Unit service processing time, which depends on the CPU Unit's CPU processing mode setting.

CPU execution mode	Processing time details	
Normal Mode (See note.)	Set peripheral servicing time Default: 4% of CPU Unit cycle time (10% for CJ2 CPU Units)	
Priority peripheral servicing	EtherNet/IP Unit or built-in EtherNet/IP port is given priority.	Time slice peripheral servicing execution time
	EtherNet/IP Unit or built-in EtherNet/IP port is not given priority.	Set peripheral servicing time (Default: 4% of CPU Unit cycle time)
Parallel processing with synchronous memory access	Set peripheral servicing time Default: 4% of CPU Unit cycle time (10% for CJ2 CPU Units)	
Parallel processing with asynchronous memory access	1 ms max.	

**Note** CJ2 CPU Units support only Normal Mode.

For details, refer to the *CPU Unit's Operation Manual*.

**Note** Depending on the actual operating environment, the transmission time may be longer than the one calculated with the equations given here. The following factors can cause longer transmission times: other traffic on the network, window sizes of network nodes, other traffic at the EtherNet/IP Unit or built-in EtherNet/IP port itself (e.g., simultaneous tag data link communications), and the system configuration.

**Example Calculation**

In this example, SEND(090) is used to send 256 words of data between two PLCs. The maximum transmission delay is calculated based on the following operating conditions.

- Local node's CPU cycle time: 10 ms
- Local node's CPU execution mode: Normal
- Local node's CPU peripheral servicing time: Default (4%)
- Remote node's CPU cycle time: 5 ms
- Remote node's CPU execution mode: Normal
- Remote node's CPU peripheral servicing time: Default (4%)
- Baud rate: 100Base-TX

Item	Calculated value
CPU Bus Unit service cycle (local node)	10 ms
CPU Bus Unit service processing time (local node)	0.4 ms
Send processing	$(256 \times 0.002) + 0.550 = 1.062 \approx 1.1$ ms
Transmission delay	$(256 \times 0.0013) + 0.0118 = 0.3446 \approx 0.3$ ms
Receive processing	$(256 \times 0.003) + 0.704 = 1.472 \approx 1.5$ ms
CPU Bus Unit service cycle (remote node)	5 ms
CPU Bus Unit service processing time (remote node)	0.2 ms
Maximum transmission delay	$10 + 0.4 + 1.1 + 0.3 + 1.5 + 5 + 0.2 = 18.5$ ms

**RECV(098) Instruction**

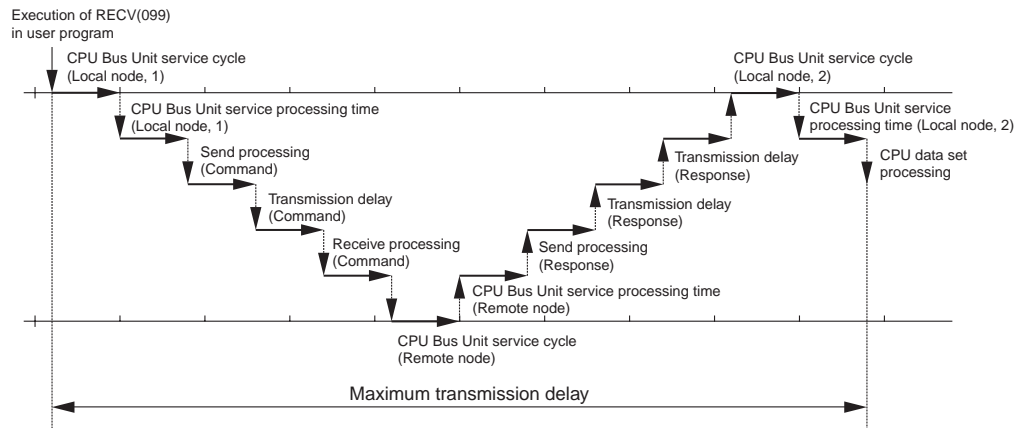

Maximum transmission delay =

- + CPU Bus Unit service cycle (Local node, 1)
- + CPU Bus Unit service processing time (Local node, 1)
- + Send processing (Command)
- + Transmission delay (Command)
- + Receive processing (Command)
- + CPU Bus Unit service cycle (remote node)
- + CPU Bus Unit service processing time (remote node)
- + Send processing (Response)
- + Transmission delay (Response)
- + Receive processing (Response)
- + CPU Bus Unit service cycle (Local node, 2)
- + CPU Bus Unit service processing time (Local node, 2)

**CPU Bus Unit Service Cycle (Local Node, 1)**

The following table shows the service cycle, which depends on the CPU Unit's CPU processing mode setting.

CPU execution mode	Processing time details
Normal Mode (See note.)	One CPU Unit cycle time
Priority peripheral servicing	
Parallel processing with synchronous memory access	0.2 ms + peripheral servicing time (1 ms max. for peripheral servicing of each Special I/O Unit, CPU Bus Unit, peripheral port, RS-232C port, and Inner Board)
Parallel processing with asynchronous memory access	

**Note** CJ2 CPU Units support only Normal Mode.

For details, refer to the *CPU Unit's Operation Manual*.

**CPU Bus Unit Service Processing Time (Local Node, 1)**

The following table shows the CPU Bus Unit service processing time, which depends on the CPU Unit's CPU processing mode setting.

CPU execution mode	Processing time details
Normal Mode (See note.)	Set peripheral servicing time
Priority peripheral servicing	Default: 4% of CPU Unit cycle time (10% for CJ2 CPU Units)
Parallel processing with synchronous memory access	1 ms max.
Parallel processing with asynchronous memory access	

**Note** CJ2 CPU Units support only Normal Mode.

For details, refer to the *CPU Unit's Operation Manual*.

**Send Processing**

Command	0.550 ms
Response	(Number of words being transferred × 0.002) + 0.550 ms

**Transmission Delay**

The transmission delay time depends on the baud rate set for the EtherNet/IP Unit or built-in EtherNet/IP port, as shown in the following table. (There may be additional delays due to the other devices in the network, such as switching hubs.)

Baud rate	Delay time	
100Base-TX	Command	0.0118 ms
	Response	(Number of words transferred × 0.0013) + 0.0118 ms
10Base-T	Command	0.0157 ms
	Response	(Number of words transferred × 0.0019) + 0.0157 ms

**Receive Processing**

Command	0.704 ms
Response	(Number of words being transferred × 0.003) + 0.704 ms

**CPU Bus Unit Service Cycle (Remote Node)**

The following table shows the CPU Bus Unit service cycle, which depends on the CPU Unit's CPU processing mode setting.

CPU execution mode	Processing time details	
Normal Mode (See note.)	One CPU Unit cycle time	
Priority peripheral servicing	EtherNet/IP Unit or built-in EtherNet/IP port is given priority.	Time slice instruction execution time
	EtherNet/IP Unit or built-in EtherNet/IP port is not given priority.	One CPU Unit cycle time
Parallel processing with synchronous memory access	One CPU Unit cycle time	
Parallel processing with asynchronous memory access	0.2 ms + peripheral servicing time (1 ms max. for peripheral servicing of each Special I/O Unit, CPU Bus Unit, peripheral port, RS-232C port, and Inner Board)	

**Note** CJ2 CPU Units support only Normal Mode.

For details, refer to the *CPU Unit's Operation Manual*.

**CPU Bus Unit Service Processing Time (Remote Node)**

The following table shows the CPU Bus Unit service processing time, which depends on the CPU Unit's CPU processing mode setting.

CPU execution mode	Processing time details	
Normal Mode (See note.)	4% of CPU Unit cycle time (10% for CJ2 CPU Units)	
Priority peripheral servicing	EtherNet/IP Unit or built-in EtherNet/IP port is given priority.	Time slice peripheral servicing execution time
	EtherNet/IP Unit or built-in EtherNet/IP port is not given priority.	Set peripheral servicing time (Default: 4% of CPU Unit cycle time)



CPU execution mode	Processing time details
Parallel processing with synchronous memory access	4% of CPU Unit cycle time
Parallel processing with asynchronous memory access	1 ms max.

**Note** CJ2 CPU Units support only Normal Mode.

For details, refer to the *CPU Unit's Operation Manual*.

**CPU Bus Unit Service Cycle (Local Node, 2)**

The following table shows the CPU Bus Unit service cycle, which depends on the CPU Unit's CPU processing mode setting.

CPU execution mode	Processing time details	
Normal Mode (See note.)	One CPU Unit cycle time	
Priority peripheral servicing	EtherNet/IP Unit or built-in EtherNet/IP port is given priority.	Time slice instruction execution time
	EtherNet/IP Unit or built-in EtherNet/IP port is not given priority.	One CPU Unit cycle time
Parallel processing with synchronous memory access	One CPU Unit cycle time	
Parallel processing with asynchronous memory access	0.2 ms + peripheral servicing time (1 ms max. for peripheral servicing of each Special I/O Unit, CPU Bus Unit, peripheral port, RS-232C port, and Inner Board)	

**Note** CJ2 CPU Units support only Normal Mode.

For details, refer to the *CPU Unit's Operation Manual*.

**CPU Bus Unit Service Processing Time (Local Node, 2)**

The following table shows the CPU Bus Unit service processing time, which depends on the CPU Unit's CPU processing mode setting.

CPU execution mode	Processing time details	
Normal Mode (See note.)	4% of CPU Unit cycle time (10% for CJ2 CPU Units)	
Priority peripheral servicing	EtherNet/IP Unit or built-in EtherNet/IP port is given priority.	Time slice peripheral servicing execution time
	EtherNet/IP Unit or built-in EtherNet/IP port is not given priority.	Set peripheral servicing time (Default: 4% of CPU Unit cycle time)
Parallel processing with synchronous memory access	4% of CPU Unit cycle time	
Parallel processing with asynchronous memory access	1 ms max.	

**Note** CJ2 CPU Units support only Normal Mode.

For details, refer to the *CPU Unit's Operation Manual*.

**Note** Depending on the actual operating environment, the transmission time may be longer than the one calculated with the equations given here. The following factors can cause longer transmission times: other traffic on the network, window sizes of network nodes, other traffic at the EtherNet/IP Unit or built-in EtherNet/IP port itself (e.g., simultaneous tag data link communications), and the system configuration.

**Example Calculation**

In this example, RECV(098) is used to receive 256 words of data from another PLC. The maximum transmission delay is calculated based on the following operating conditions.

- Local node's CPU cycle time: 10 ms
- Local node's CPU execution mode: Normal
- Local node's CPU peripheral servicing time: Default (4%)
- Remote node's CPU cycle time: 15 ms
- Remote node's CPU execution mode: Normal
- Remote node's CPU peripheral servicing time: Default (4%)
- Baud rate: 100Base-TX

Item	Calculated value
CPU Bus Unit service cycle (local node, 1)	10 ms
CPU Bus Unit service processing time (local node, 1)	0.4 ms
Send processing (command)	0.550 ms $\cong$ 0.5 ms
Transmission delay (command)	0.0118 ms $\cong$ 0.1 ms
Receive processing (command)	0.704 ms $\cong$ 0.7 ms
CPU Bus Unit service cycle (remote node)	15 ms
CPU Bus Unit service processing time (remote node)	0.6 ms
Send processing (command)	$(256 \times 0.002) + 0.550 = 1.062 \cong 1.1$ ms
Transmission delay (command)	$(256 \times 0.0013) + 0.0118 = 0.3446 \cong 0.3$ ms
Receive processing (command)	$(256 \times 0.003) + 0.704 = 1.472 \cong 1.5$ ms
CPU Bus Unit service cycle (local node, 2)	10 ms
CPU Bus Unit service processing time (local node, 2)	0.4 ms
Maximum transmission delay	$10 + 0.4 + 0.5 + 0.1 + 0.7 + 15 + 0.6 + 1.1 + 0.3 + 1.5 + 10 + 0.4 = 40.6$ ms

# SECTION 11

## FTP Server

This section describes the functions provided by the FTP server.

11-1	Overview and Specifications . . . . .	304
11-1-1	Overview . . . . .	304
11-1-2	Specifications . . . . .	305
11-2	FTP Server Function Details . . . . .	305
11-2-1	File Types . . . . .	305
11-2-2	Connecting to the FTP Server . . . . .	306
11-3	Using the FTP Server Function . . . . .	307
11-3-1	Procedure . . . . .	307
11-3-2	List of Settings Required for the FTP Server Function . . . . .	307
11-3-3	FTP Tab . . . . .	308
11-4	FTP Server Application Example . . . . .	309
11-5	Using FTP Commands . . . . .	310
11-5-1	Table of Commands . . . . .	310
11-5-2	Using the Commands . . . . .	310
11-5-3	Error Messages and FTP Status . . . . .	315
11-6	Checking FTP Status . . . . .	316
11-6-1	FTP Status Flag . . . . .	316
11-7	Using File Memory . . . . .	317
11-7-1	File Memory . . . . .	317
11-7-2	File Types . . . . .	317
11-7-3	Initializing File Memory . . . . .	319
11-7-4	I/O Memory Data Format . . . . .	319
11-8	FTP File Transfer Time . . . . .	322
11-9	Host Computer Application Example . . . . .	323

# 11-1 Overview and Specifications

## 11-1-1 Overview

The EtherNet/IP Unit or built-in EtherNet/IP port has a built-in FTP (File Transfer Protocol) server function, so other computers on the Ethernet can read or write (upload/download) large files in the EM file memory by executing FTP commands from the FTP client software.

FTP can be used for EtherNet/IP Units with unit version 2.0 or later.

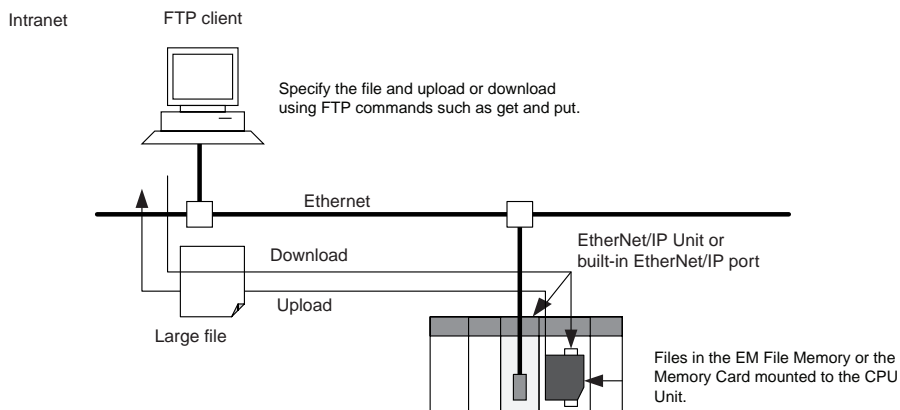

**Note** Only one FTP client can connect at the same time.

### 11-1-2 Specifications

Item	Specification
Executable commands	<p><code>open</code>: Connects the specified host FTP server.</p> <p><code>user</code>: Specifies user name for the remote FTP server.</p> <p><code>ls</code>: Displays the Memory Card file names.</p> <p><code>dir</code>: Display the Memory Card file names and details.</p> <p><code>rename</code>: Changes a file name.</p> <p><code>mkdir</code>: Creates a new directory in the working directory in the remote host.</p> <p><code>rmdir</code>: Deletes a new directory from the working directory in the remote host.</p> <p><code>cd</code>: Changes the Ethernet Unit work directory to the specified directory.</p> <p><code>cdup</code>: Changes the working directory at the remote host to the parent directory.</p> <p><code>pwd</code>: Displays the Ethernet Unit work directory.</p> <p><code>type</code>: Specifies the data type of transferred files.</p> <p><code>get</code>: Transfers the specified file from the Memory Card to the local host.</p> <p><code>mget</code>: Transfers multiple files from the Memory Card to the local host.</p> <p><code>put</code>: Transfers the specified local file to the Memory Card.</p> <p><code>mput</code>: Transfers multiple local files to the Memory Card.</p> <p><code>delete</code>: Deletes the specified file from the Memory Card.</p> <p><code>mdelete</code>: Deletes multiple files from the Memory Card.</p> <p><code>close</code>: Disconnects the FTP server.</p> <p><code>bye</code>: Closes the FTP (client).</p> <p><code>quit</code>: Closes the FTP (client).</p>
Protection	<p>FTP login name consists of 12 letters max. CONFIDENTIAL is the default login name.</p> <p>Password consists of 8 characters max.</p>
Protocol	FTP (port number: 20/TCP, 21/TCP)
Number of connections	1

**Note** The PLC, however, is unable to read or write files at other nodes using FTP because the EtherNet/IP Unit or built-in EtherNet/IP port does not support FTP client functions.

## 11-2 FTP Server Function Details

### 11-2-1 File Types

The file system in the CPU Unit that can be accessed by the EtherNet/IP Unit or built-in EtherNet/IP port includes files in any Memory Card mounted in the CPU Unit and files in the EM file memory. The directory tree is shown below.

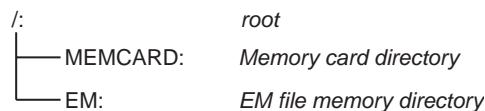

A connection will be initially made to the root directory.

- Note**
1. The date of the MEMCARD directory displayed for `ls` or `dir` commands in the root directory will be the date of the file system volume label.
  2. The login date will be displayed for EM files and for MEMCARD if a volume label has not been created.

## 11-2-2 Connecting to the FTP Server

The host computer must connect to the FTP server before the FTP server functions can be used. The login name and password set in the Unit Setup will be used when connecting. The default FTP login name is “CONFIDENTIAL” and no password is required.

The FTP server in the EtherNet/IP Unit or built-in EtherNet/IP port can connect to only one client at a time. If a client attempts to connect when the FTP server is in use, a message will be returned and connection will be refused.

**Note** When general-purpose FTP software is used, files can be transferred and read using a graphical user interface similar to Explorer.

### Login Name and Password Setting

The default login name for FTP is “CONFIDENTIAL” and no password is set for the default login, so login is possible by simply entering “CONFIDENTIAL” as the login name. A user-set login name and password can also be set in the User Setup (CPU Bus Unit System Setup).

### Login Messages

Status	Message
Normal connection	220 xxx.xx.xx.xx yyyyyyyyyy FTP server (FTP Version z.zz) ready. xxx.xx.xx.xx: IP address of EtherNet/IP Unit or built-in EtherNet/IP port yyyyyyyyyy: EtherNet/IP Unit or built-in EtherNet/IP port model number (e.g., CS1W-EIP21) z.zz: Firmware version of EtherNet/IP Unit or built-in EtherNet/IP port
FTP server busy	221 FTP server busy, Goodbye.

### Setting Restrictions

The following restrictions apply to login names and passwords.

- The login name and password must consist of alphanumeric characters, hyphens, and/or underscores. They are not case sensitive.
- A login name consists of 12 characters.
- A password consists of 8 characters.
- Always set a password when setting a new login name. The login name will not be valid unless a password is set for it.
- If a login name is not set or contains illegal characters, the default login name, CONFIDENTIAL, must be used. No password is required and any password that is set will be ignored.

### FTP File Transfer Mode

FTP has two file transfer modes: ASCII mode and binary mode. Before starting to transfer files, use the `type` command (specifies the data type of transferred files) to select the required mode.

Always select binary mode for binary files (extensions .IOM, .STD, or .OBJ) in the CS/CJ-series file memory and other program files (with extensions such as .CXP).

## 11-3 Using the FTP Server Function

### 11-3-1 Procedure

- 1,2,3...
1. Make the basic settings.  
Refer to *Initial Settings* on page 34.
  2. When using a user-set FTP login name and password:  
With the CX-Programmer online, right-click the EtherNet/IP Unit or built-in EtherNet/IP port in the IO Table Dialog Box of the CX-Programmer, and select **Edit - Unit Setup**. Set the following on the FTP Tab Page of the Edit Parameters Dialog Box.
    - FTP login name
    - FTP password.
  3. Select **Transfer to PLC** from the PLC Menu and click the **Yes** Button. The setting data will be transferred to the CPU Bus Unit System Setup Area in the CPU Unit.
  4. When reading from and writing to the Memory Card:  
Mount the Memory Card into the CPU Unit.
  5. Connect the EtherNet/IP Unit or built-in EtherNet/IP port using the FTP client software.
  6. Enter the FTP login name and password set in the Unit Setup and log into the EtherNet/IP Unit or built-in EtherNet/IP port.
 

**Note** Once logged in, the ftp commands can be used, such as cd (Change Directory), and get (Obtain File).
  7. Search in the following directories for the required file in the Memory Card mounted to the CPU Unit or the EM File Memory.

File memory type	Directory
Memory Card	\MEMCARD
EM File Memory	\EM

8. Download the files.
9. Exit the connection.

**Note** The EtherNet/IP Unit or built-in EtherNet/IP port will be restarted when the settings data is transferred to the CPU Bus Unit System Setup Area, so that the new settings are read and become effective. Verify that it is safe for the EtherNet/IP Unit or built-in EtherNet/IP port to restart before transferring the settings data.

### 11-3-2 List of Settings Required for the FTP Server Function

Make the following settings for the unit setup when the server function is used.

CX-Programmer tab	Settings	Setting conditions	Page
FTP	Login	User-set (when the default, CONFIDENTIAL, is not used)	308
	Password	User-set	
	Port No.	Rarely required (when the default, 21, is not used)	

## 11-3-3 FTP Tab

The CPU Bus Unit System Setup, which is set when using the FTP server function, is shown in the CX-Programmer's Edit Parameters Dialog Box.

The screenshot shows the 'CJ1W-EIP21 [Edit Parameters]' dialog box with the 'FTP' tab selected. The 'Use FTP' radio button is checked. The 'Login' field is empty, the 'Password' field is empty, and the 'Port No.' field contains '0'. Below the fields are buttons for 'Transfer[Unit to PC]', 'Transfer[PC to Unit]', 'Compare', 'Restart', 'Set Defaults', 'OK', and 'Cancel'.

#### ■ Settings

Setting	Details	Default value
Login	Set the login name to externally connect to the EtherNet/IP Unit or built-in EtherNet/IP port via FTP.	None (CONFIDENTIAL is used.)
Password	Set the password to externally connect to the EtherNet/IP Unit or built-in EtherNet/IP port via FTP.	None
Port No.	FTP port number of the EtherNet/IP Unit or built-in EtherNet/IP port.  This setting does not normally need to be changed.  FTP uses two ports: a port for control and a port for data transfer. Set the control port only. The data transfer port uses the value set for the control port -1.	0 (21 is used.)



# 11-4 FTP Server Application Example

The following procedure shows how to use the FTP server by connection with the default login name, CONFIDENTIAL. No password is required.

**Note** The login name and a password must be set in the CPU Bus Setup for the Ethernet Unit in the CPU Unit to use any login name other than CONFIDENTIAL.

**Note** When general-purpose FTP software is used, files can be transferred and read using a graphical user interface similar to Explorer.

- 1,2,3...**
1. Make sure that a Memory Card is inserted in the CPU Unit and turn ON the power supply to the PLC. If EM File Memory is to be used, create the EM File Memory.
  2. Connect to the FTP server from a computer on the Ethernet by entering the text that is underlined in the following diagram.

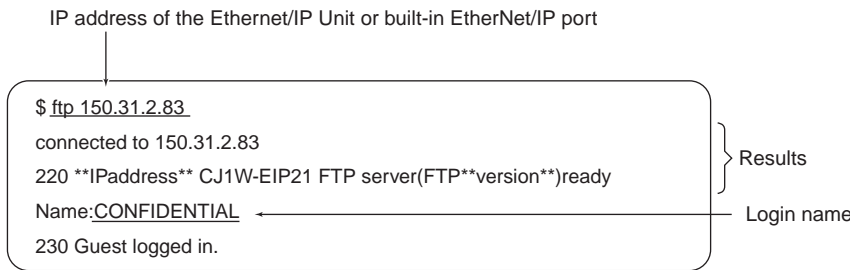

3. Enter FTP commands (underlined in the following diagram) to read and write files. The following directory tree is used in this example.

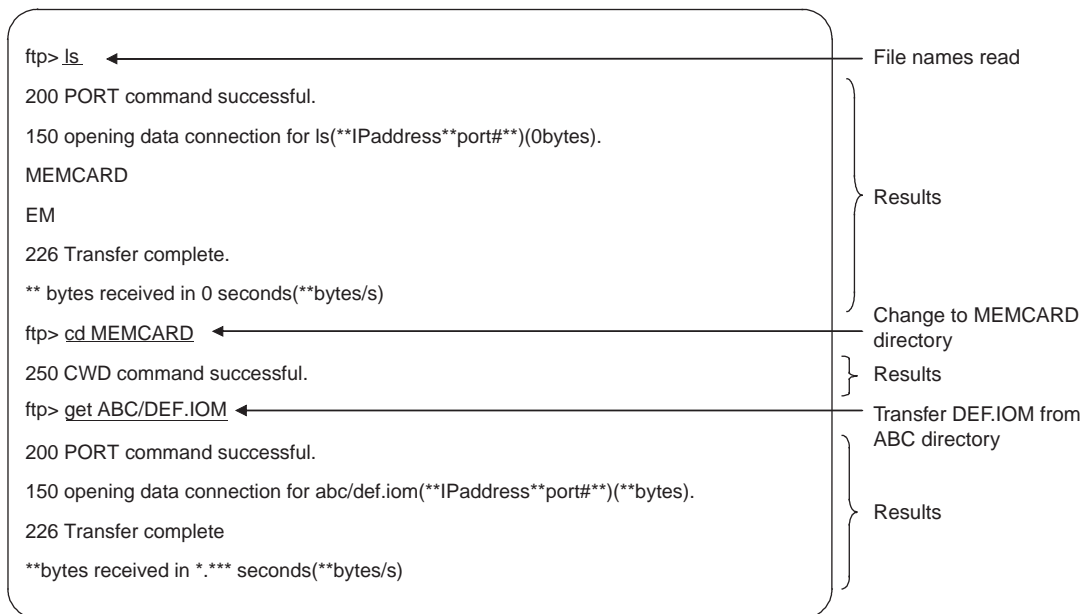
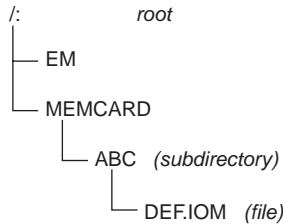

## 11-5 Using FTP Commands

This section describes the FTP commands which the host computer (FTP client) can send to the FTP server of the EtherNet/IP Unit or built-in EtherNet/IP port. The descriptions should also apply to most UNIX workstations, but slight differences may arise. Refer to your workstation's operation manuals for details.

### 11-5-1 Table of Commands

The FTP commands which can be sent to the EtherNet/IP Unit or built-in EtherNet/IP port are listed in the following table.

Command	Description
open	Connects the specified host FTP server.
user	Specifies user name for the remote FTP server.
ls	Displays the Memory Card file names.
dir	Display the Memory Card file names and details.
rename	Changes a file name.
mkdir	Creates a new directory in the working directory in the remote host.
rmdir	Deletes a new directory from the working directory in the remote host.
cd	Changes the Ethernet Unit work directory to the specified directory.
cdup	Changes the working directory at the remote host to the parent directory.
pwd	Displays the Ethernet Unit work directory.
type	Specifies the data type of transferred files.
get	Transfers the specified file from the Memory Card to the local host.
mget	Transfers multiple files from the Memory Card to the local host.
put	Transfers the specified local file to the Memory Card.
mput	Transfers multiple local files to the Memory Card.
delete	Deletes the specified file from the Memory Card.
mdelete	Deletes multiple files from the Memory Card.
close	Disconnects the FTP server.
bye	Closes the FTP (client).
quit	Closes the FTP (client).

- The EtherNet/IP Unit or built-in EtherNet/IP port is considered to be the remote host and the host computer (FTP client) is considered to be the local host.
- A remote file is a file on the Memory Card or in EM File Memory in the CPU Unit. A local file is one in the host computer (FTP client).
- The parent directory is the directory one above the working directory.

### 11-5-2 Using the Commands

#### **open**

#### **Format**

```
open [IP_address or host_name_of_FTP_server]
```

#### **Function**

Connects the FTP server. Normally when the FTP client is booted, the FTP server IP address is specified to execute this command automatically.

**user****Format**

```
user [user_name]
```

**Function**

Specifies the user name. Specify the FTP login name set in the EtherNet/IP Unit or built-in EtherNet/IP port system setup. The default FTP login name is "CONFIDENTIAL."

If a non-default login name is used, it must be followed by the password. In this case, enter the FTP password set in the system setup.

The user name is automatically requested immediately after connection to the FTP server.

**ls****Format**

```
ls [-l] [REMOTE_FILE_NAME [local_file_name]]
```

**Function**

Displays the remote host (Memory Card or EM File Memory) file names.

Set the switch [-l] to display not only the file names but the creation date and size as well. If the switch is not set, only the file names will be displayed.

You can specify a file name in the Memory Card or EM File Memory if desired.

If a local file name is specified, the file information will be stored in the specified file in the host computer.

**dir****Format**

```
dir [REMOTE_FILE_NAME [local_file_name]]
```

**Function**

Displays the file names, date created, and size of the files in the remote host (Memory Card or EM File Memory). It displays the same information as command [ls -l].

Specify a file name in the Memory Card or EM File Memory as the remote file name.

If a local file name is specified, the file information is stored in the specified file in the host computer.

**rename****Format**

```
rename CURRENT_FILE_NAME NEW_FILE_NAME
```

**Function**

Changes the specified current file name to the specified new file name.

`rename` can be used only to change the file name. It cannot be used to move the file to a different directory.

**mkdir****Format**

```
mkdir DIRECTORY_NAME
```

**Function**

Creates a directory of the specified name at the remote host (Memory Card or EM File Memory).

An error will occur if a file or directory of the same name already exists in the working directory.

**rmdir****Format**

```
rmdir DIRECTORY_NAME
```

**Function**

Deletes the directory of the specified name from the remote host (Memory Card or EM File Memory).

The directory must be empty to delete it.

An error will occur if the specified directory does not exist or is empty.

**pwd****Format**

```
pwd
```

**Function**

Displays the remote host's (Ethernet Unit) current work directory.

**cd****Format**

```
cd [directory_name]
```

**Function**

Changes the remote host (Ethernet Unit) work directory to the specified remote directory.

The files in the Memory Card are contained in the MEMCARD directory under the root directory (/). The files in EM File Memory are contained in the EM directory under the root directory (/). The root directory (/) is the directory used when logging into the EtherNet/IP Unit or built-in EtherNet/IP port. No MEMCARD directory will exist if a Memory Card is not inserted in the PLC or if the Memory Card power indicator is not lit. No EM directory will exist if EM File Memory does not exist.

**cdup****Format**

```
cdup
```

**Function**

Changes the working directory at the remote host to the parent directory (one directory above the current working directory).

**type****Format**

```
type data_type
```

**Function**

Specifies the file data type. The following data types are supported:

ascii: Files are transferred as ASCII data  
binary (image): Files are transferred as binary data.

All files are treated by the PLC as binary files. Before reading or writing any files, always use the `type` command to set the file type to binary. File contents cannot be guaranteed if transferred as ASCII data.

The default file type is ASCII.

**get****Format**

```
get FILE_NAME [receive_file_name]
```

**Function**

Transfers the specified remote file from the Memory Card or EM File Memory to the local host.

A receive file name can be used to specify the name of the file in the local host.

**mget****Format**

```
mget FILE_NAME
```

**Function**

Allows the use of a wildcard character (\*) to transfer multiple remote files from the Memory Card or EM File Memory to the local host.

**put****Format**

```
put file_name [DESTINATION_FILE_NAME]
```

**Function**

Transfers the specified local file to the remote host (Memory Card or EM File Memory).

A destination file name can be used to specify the name the file is stored under in the Memory Card or EM File Memory.

Any existing file with the same name in the remote host (Memory Card or EM File Memory) will be overwritten by the contents of the transferred file.

If an error occurs during file transfer, the file being transferred will be deleted and the transmission will end in an error.

**mput****Format**

```
mput FILE_NAME
```

**Function**

Allows the use of a wildcard character (\*) to transfer multiple local files to the remote host (Memory Card or EM File Memory).

Any existing file with the same name in the remote host (Memory Card or EM File Memory) will be overwritten by the contents of the transferred file.

If an error occurs during file transfer, the file being transferred will be deleted and the transmission of that file will end in an error. However, mput execution will continue and remaining files will be transferred.

**delete****Format**

```
delete FILE_NAME
```

**Function**

Deletes the specified remote file from the Memory Card or EM File Memory.

**mdelete****Format**

```
mdelete FILE_NAME
```

**Function**

Allows the use of a wildcard character (\*) to delete multiple remote files from the Memory Card or EM File Memory.

**close****Format**

```
close
```

**Function**

Disconnects the FTP server of the EtherNet/IP Unit or built-in EtherNet/IP port.

**bye****Format**

```
bye
```

**Function**

Ends the FTP (client).

**quit****Format**

```
quit
```

**Function**

Ends the FTP (client).

### 11-5-3 Error Messages and FTP Status

#### Error Messages

The error messages returned by the EtherNet/IP Unit or built-in EtherNet/IP port are listed in the following table.

Message	Meaning
PPP is a directory.	The path name indicated at PPP is a directory.
PPP is not a directory.	The path name indicated at PPP is not a directory.
Another unit has access authority (FINS error 0 x 3001).	Another Unit currently has the access right.
Bad sequence of commands.	The RNFR command has not been executed.
Can't create data socket (X.X.X.X, YY).	A socket cannot be created.
Cannot access to device (FINS error 0 x 250F).	A file device error has occurred.
Cannot get memory blocks.	A message memory block cannot be allocated.
Command format error (FINS error 0 x 1003).	The command format is incorrect.
Connect error.	A connection error has occurred.
Directories of old and new paths are not same.	The directories before and after changing the name are different.
Directory name length exceeded max. size.	The directory name is too long.
Directory not empty (FINS error 0 x 2108).	The directory must be empty to delete it.
Fatal error (FINS error 0 x 1101).	A parameter error has occurred.
Fatal error (FINS error 0 x 1103).	
File or directory already exists.	The specified file or directory name already exists.
File or directory already exists (FINS error 0 x 2107).	
File or directory name illegal.	
File or directory name illegal (FINS error 0 x 110C).	The file or directory name is incorrect.
File read error (FINS error 0 x 1104).	
File read error (FINS error 0 x 110B).	An error occurs when reading the file.
File write error (FINS error 0 x 2106).	
File write error (FINS error 0 x 2107).	
FINS error MRES 0 x XX: SRES 0 x XX.	Some other FINS error has occurred.
Length of directory name too long.	The path name of the directory is too long.
No space to create entry (FINS error 0 x 2103).	There are too many files to create a new one.
No such device (FINS error 0 x 2301).	The file device cannot be found.
No such file or directory.	The specified file or directory does not exist.
No such file or directory (FINS error 0 x 2006).	
No such file or directory (FINS error 0 x 2106).	
Not enough memory.	The communications buffers are full.
Not enough space in the system. (FINS error 1104).	The file device is full.
PLC communication error (timeout).	File access timed out.
Socket canceled.	The socket was canceled.
Socket error NN.	A socket bind error occurred. The error code will be given at NN.
Socket receive error NN.	A data reception error occurred. The error code will be given at NN.
Socket send error NN.	A data send error occurred. The error code will be given at NN.
Timeout (900 seconds): closing control connection.	The connection was closed because the client did not respond for 15 minutes.
Too many open files.	Too many sockets have been created.
Write access denied.	Writing is not possible.
Write access denied. (FINS error 0 x 2101).	

PPP: Path name  
 XXX: IP address  
 YY: Port number  
 MM: FINS error code  
 NN: Socket error code

## 11-6 Checking FTP Status

### 11-6-1 FTP Status Flag

The current status of the FTP server can be obtained from the service status in the words allocated to the EtherNet/IP Unit in the CPU Bus Unit Area in the CIO Area. The word containing the FTP Status Flag can be computed as follows: CIO 1500 + (25 x unit number) + 13

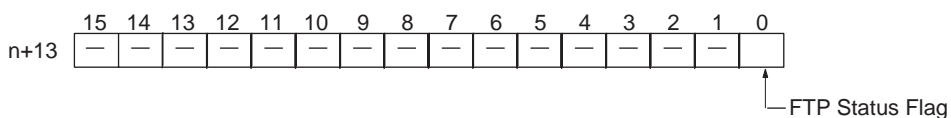

Status of bit 00	Meaning
1	FTP server busy (a user is connected)
0	FTP server free

- Note**
- File operations for files on the Memory Card are performed during FTP communications. Do not remove the Memory Card or turn OFF power to the PLC while FTP is being used.
  - When using File Memory Instruction from the program in the CPU Unit, program exclusive control using the FTP Status Flag so that the same data is not manipulated simultaneously by more than one instruction.



## 11-7 Using File Memory

There are two media that can be used to store files in memory for CS/CJ-series PLCs:

- Memory Cards
- EM File Memory

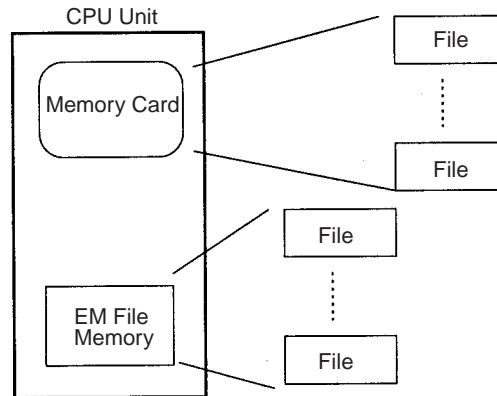

### 11-7-1 File Memory

Media	Memory type	Capacity	Model	File data recognized by CPU Unit
CS/CJ-series Memory Cards	Flash memory	8 MB	HMC-EF861	<ul style="list-style-type: none"> <li>• Complete user program</li> <li>• Specified portions of I/O Memory</li> <li>• Parameter area data (e.g. PLC Setup)</li> </ul>
		15 MB	HMC-EF171	
		30 MB	HMC-EF371	
EM File Memory	RAM	Max. capacity of EM Area in CPU Unit	All EM Area banks from specified bank in I/O Memory (specified in PLC Setup)	

### 11-7-2 File Types

#### ■ File Names

Files are distinguished by assigning file names and extensions. The following characters can be used in file names and extensions:

Alphanumeric characters: A to Z and 0 to 9. (Names converted to all-caps)  
! & \$ # ' [ ] - ^ ( ) \_

The following characters cannot be used in files names and extensions:

, . / ? \* " : ; < > = + (spaces)

File names are not case sensitive and will be converted to all-caps in the PLC file system. File names can be up to 8 character long with 3-character extensions. An error will occur if a file name or extension is too long. The first period (.) in a file name will be taken as the delimiter between the file name and extension. Extensions are determined by the file type.

#### ■ Directories

Up to five levels of directories (including root as the first level) can be created as file storage locations. A maximum of 65 characters can be used in directory names.

## File Names Handled by CPU Unit

The files described in the following table can be read or written by the CPU Unit.

File type		File name	Extension	Contents	Description
Data file		*****	.IOM	Specified ranges of I/O Memory	<ul style="list-style-type: none"> <li>Contains word (16-bit) data from a starting word through an end word in one memory area.</li> <li>The following areas can be used: CIO, HR, WR, AR, DM, and EM.</li> </ul>
Program file		*****	.OBJ	Complete user program	<ul style="list-style-type: none"> <li>Contains all the programs for cyclic tasks and interrupt tasks, as well as task information for one CPU Unit.</li> </ul>
Parameter area file		*****	.STD	<ul style="list-style-type: none"> <li>PLC Setup</li> <li>Registered I/O tables</li> <li>Routing tables</li> <li>CPU Bus Unit Setup and other setup data</li> </ul>	<ul style="list-style-type: none"> <li>Contains all of the parameter data for one CPU Unit.</li> <li>There is no need for the user to distinguish the various types of data contained in the file.</li> <li>The file can be automatically read to or written from the CPU Unit simply by specifying the extension (.STD)</li> </ul>
Files transferred at startup	Data files	AUTOEXEC	.IOM	I/O Memory data for the specified number of words starting from D20000	<ul style="list-style-type: none"> <li>There does not necessarily need to be a data file in the Memory Card when the automatic file transfer function is used at startup.</li> <li>The AUTOEXEC.IOM file always contains DM Area data starting at D20000.</li> <li>All data in the file will be transferred to memory starting at D20000 at startup.</li> </ul>
	Program files	AUTOEXEC	.OBJ	Complete user program	<ul style="list-style-type: none"> <li>There must be a program file in the Memory Card when the automatic file transfer function is used at startup.</li> <li>Contains all the programs for cyclic tasks and interrupt tasks, as well as task information for one CPU Unit.</li> </ul>
	Parameter area file	AUTOEXEC	.STD	<ul style="list-style-type: none"> <li>PLC Setup</li> <li>Registered I/O tables</li> <li>Routing tables</li> <li>CPU Bus Unit Setup and other setup data</li> </ul>	<ul style="list-style-type: none"> <li>There must be a parameter file in the Memory Card when the automatic file transfer function is used at startup.</li> <li>Contains all of the parameter data for one CPU Unit.</li> <li>There is no need for the user to distinguish the various types of data contained in the file.</li> <li>All parameters in the file will be automatically transferred to specified locations in memory at startup.</li> </ul>

- Note**
1. Refer to information on file memory in the *CS/CJ-series Programmable Controllers Operation Manual (W339)*.
  2. All files transferred automatically at startup must have the name AUTOEXEC.

### 11-7-3 Initializing File Memory

Memory	Initialization method
Memory Cards	<ol style="list-style-type: none"> <li>1. Insert the Memory Card into the CPU Unit.</li> <li>2. Initialize the Memory Card from a Programming Device (Programming Consoles included).</li> </ol>
EM File Memory	<ol style="list-style-type: none"> <li>1. Specify in the PLC Setup the first bank to convert to file memory.</li> <li>2. Initialize EM File Memory from the CX-Programmer.</li> </ol>

### 11-7-4 I/O Memory Data Format

#### ■ IOM Format

The IOM format is a data format used for binary data specified by the ladder instructions, READ DATA FILE (FREAD(700)) and WRITE DATA FILE (FWRITE(701)), in the CPU Unit.

If five words of data from the I/O memory (1234 hexadecimal, 5678 hexadecimal, 9ABC hexadecimal, etc.) is contained in an attached file in IOM format, the data will be stored in the attached file as shown in the following diagram.

Example: Binary data format with a delimiter after every 10 fields.

I/O memory

	+0	+1	+2	+3	+4	+5	+6	+7	+8	+9
+0	1234	5678	9ABC	DEF0	1234	5678	9ABC	DEF0	1234	5678
+10	9ABC	DEF0	1234	5678	9ABC	DEF0	1234	5678	9ABC	DEF0



.IOM file contents

XX	XX	...	XX	12	34	56	78	9A	BC	DE	F0	12	34	...
----	----	-----	----	----	----	----	----	----	----	----	----	----	----	-----

48 bytes

(Reserved by the system.)

#### ■ TXT Format

The TXT format is a data format (using tab delimiters) specified by the ladder instructions, READ DATA FILE (FREAD(700)) and WRITE DATA FILE (FWRITE(701)), in the CPU Unit. The format is configured according to the specified FREAD(700) and FWRITE(701) parameters, as follows:

Data format	Use of CRs and CR position
<ul style="list-style-type: none"> <li>• Words without delimiters</li> <li>• Double words without delimiters</li> <li>• Words delimited by tabs.</li> <li>• Double words delimited by tabs</li> </ul>	<ul style="list-style-type: none"> <li>• No CRs</li> <li>• CR after every 10 fields.</li> <li>• CR after each field.</li> <li>• CR after every 2 fields.</li> <li>• CR after every 4 fields.</li> <li>• CR after every 5 fields.</li> <li>• CR after every 16 fields.</li> </ul>

If data from the I/O memory (1234 hexadecimal, 5678 hexadecimal, 9ABC hexadecimal, etc.) is contained in an attached file in TXT format, the data will be converted into ASCII format in words or double-words. The words are delimited by inserting tabs ([HT]: 09), and carriage returns (CR) after specified fields ([CR][LF]: 0D0A).

Example: Data format using words delimited by tabs and CRs after every 10 fields.

I/O memory

	+0	+1	+2	+3	+4	+5	+6	+7	+8	+9
+0	1234	5678	9ABC	DEF0	1234	5678	9ABC	DEF0	1234	5678
+10	9ABC	DEF0	1234	5678	9ABC	DEF0	1234	5678	9ABC	DEF0



.TXT file contents

31	32	33	34	09	35	36	37	38	09	39	41	42	43	09	...
1	2	3	4	[HT]	5	6	7	8	[HT]	9	A	B	C	[HT]	...
...	35	36	37	38	0D	0A	39	41	42	43	09	...			
...	5	6	7	8	[CR][LF]	9	A	B	C	[HT]	...				



.TXT file displayed as text

```
1234□5678□9ABC□DEF0□1234□5678□9ABC□DEF0□1234□5678
9ABC□DEF0□1234□5678□9ABC□DEF0□1234□5678□9ABC□DEF0
```

□...[HT]: Used to display tab space when displayed as text.

■ CSV Format

The CSV format is a data format (using comma delimiters) that is specified by ladder instructions, READ DATA FILE (FREAD(700)) and WRITE DATA FILE (FWRITE(701)), in the CPU Unit. The CSV format is configured according to the specified FREAD(700) and FWRITE(701) parameters, as follows:

Data format	Use of CRs and CR position
Words delimited by commas. Double words delimited by commas.	<ul style="list-style-type: none"> <li>• No CRs</li> <li>• CR after every 10 fields.</li> <li>• CR after each field.</li> <li>• CR after every 2 fields.</li> <li>• CR after every 4 fields.</li> <li>• CR after every 5 fields.</li> <li>• CR after every 16 fields.</li> </ul>

If word data from the I/O memory (1234 hexadecimal, 5678 hexadecimal, up to DEF0 hexadecimal) is contained in an attached file in CSV format, the word data will be converted into ASCII format in word or double-word units. The words are delimited by inserting comma delimiters (',':2C), and CRs after specified fields ([CR][LF]: 0D0A).

Example: Data format using words delimited by commas with CRs after every 10 fields.

I/O memory

	+0	+1	+2	+3	+4	+5	+6	+7	+8	+9
+0	1234	5678	9ABC	DEF0	1234	5678	9ABC	DEF0	1234	5678
+10	9ABC	DEF0	1234	5678	9ABC	DEF0	1234	5678	9ABC	DEF0



.CSV file contents

31	32	33	34	2C	35	36	37	38	2C	39	41	42	43	2C	...
1	2	3	4	,	5	6	7	8	,	9	A	B	C	,	...
...	35	36	37	38	0D	0A	39	41	42	43	2C	...			
...	5	6	7	8	[CR]	[LF]	9	A	B	C	,	...			



.TXT file displayed as text

1234,5678,9ABC,DEF0,1234,5678,9ABC,DEF0,1234,5678 9ABC,DEF0,1234,5678,9ABC,DEF0,1234,5678,9ABC,DEF0
--

- Note** FREAD(700) will not be able to read the last byte in a file that has been written to the Memory Card if the file contains an odd number of bytes. Add 00 hexadecimal to the end of the file if necessary to write an even number of bytes to the Memory Card.
- Note** The UM and DM Areas contain binary data. Set the data type to binary using the `type` command before reading or writing files using FTP. (Refer to `type` on page 313.)
- Note** For details on how to use File Memory Instructions, refer to the *CS/CJ Series Instructions Reference Manual (W474)*.

## 11-8 FTP File Transfer Time

File transfers using FTP can require 30 or 40 minutes depending on the capacity of the file. Approximate file transfer time are provided in the following table for reference.

All times are in seconds unless otherwise specified.

### ■ CS1 CPU Units and CJ1 CPU Units

File system		Memory Card		EM File Memory	
CPU Unit status	Operating mode	PROGRAM	RUN	PROGRAM	RUN
	Cycle time	---	20 ms	---	20 ms
Transfers using put	1 KB	0.7 s	6.0 s	0.4 s	2.9 s
	30 KB	4.5 s	38.3 s	2.5 s	21.5 s
	60 KB	7.4 s	72.1 s	5.0 s	44.7 s
	120 KB	14.4 s	141.4 s	11.0 s	120.8 s
Transfers using get	1 KB	0.3 s	1.4 s	0.2 s	0.8 s
	30 KB	2.8 s	19.3 s	1.9 s	11.4 s
	60 KB	4.9 s	37.6 s	3.8 s	26.7 s
	120 KB	9.6 s	75.7 s	8.6 s	68.2 s

### ■ CS1-H CPU Units, CJ1-H CPU Units, CJ1-R CPU Units, CJ2-H CPU Units, and CJ2M CPU Units

File system		Memory Card		EM File Memory	
CPU Unit status	Operating mode	PROGRAM	RUN	PROGRAM	RUN
	Cycle time	---	20 ms	---	20 ms
Transfers using put	1 KB	0.5 s	2.7 s	0.2 s	0.6 s
	30 KB	1.8 s	11.6 s	0.7 s	6.6 s
	60 KB	3.2 s	21.1 s	1.5 s	14.0 s
	120 KB	6.2 s	40.2 s	3.6 s	32.5 s
Transfers using get	1 KB	0.2 s	0.3 s	0.2 s	0.2 s
	30 KB	1.7 s	4.8 s	1.0 s	4.1 s
	60 KB	2.5 s	9.4 s	2.3 s	9.7 s
	120 KB	4.9 s	18.8 s	4.9 s	27.0 s

- Note**
1. The above times assume that the Fixed Peripheral Servicing Time in the PLC Setup is set to the default value of 4%.
  2. If the Fixed Peripheral Servicing Time in the PLC Setup is increased, FTP files will be transferred faster.

## 11-9 Host Computer Application Example

The following procedure provides an example of FTP operations from a host computer. In this example, the following assumptions are made.

- The IP address of the EtherNet/IP Unit or built-in EtherNet/IP port is registered in /etc/hosts on the host name as [cs1].
- The default FTP login name is being used (CONFIDENTIAL).
- A processing results data file called RESULT.IOM already exists on the Memory Card in the CPU Unit.
- A processing instructions data file called PLAN.IOM already exists on the workstation.

The following procedure transfers the processing results file RESULT.IOM from the Memory Card in the CPU Unit to the workstation and then the processing instructions file PLAN.IOM is transferred from the workstation to the Memory Card in the CPU Unit.

Underlined text is keyed in from the FTP client. The workstation prompt is indicated as \$ and the cursor is indicated as ■.

- 1,2,3...** 1. Start FTP and connect to the EtherNet/IP Unit or built-in EtherNet/IP port.

```
$ ftp cs1 ... FTP started.  
connected to cs1  
220 **IPAddress** CS1W-ETN21 FTP server(FTP**version**)ready  
Name(cs1:root): ■
```

2. Enter the login name.

```
Name(cs1:root):CONFIDENTIAL ... Login name  
230 Guest logged in.  
ftp> ■
```

3. Make sure the Memory Card is inserted. The MEMCARD directory will be displayed if there is a Memory Card in the CPU Unit.

```
ftp> ls ... Make sure the Memory Card is inserted.  
200 PORT command successful.  
150 opening data connection for ls(**IPAddress**port#**)(0 bytes).  
MEMCARD  
226 Transfer complete.  
15 bytes received in 0 seconds(**bytes/s)  
ftp> ■
```

## 4. Change to the MEMCARD directory.

```
ftp> cd MEMCARD ... Change to MEMCARD directory.  
250 CWD command successful.  
ftp> ■
```

## 5. Change data type to binary.

```
ftp> type binary ... Binary data type set.  
200 Type set to I.  
ftp> ■
```

## 6. Transfer the file RESULT.IOM to the workstation.

```
ftp> get RESULT.IOM ... File read.  
200 PORT command successful.  
150 opening data connection for result.iom (**IPAddress**port#**).  
226 Transfer complete.  
** bytes received in *.* seconds (**bytes/s)  
ftp> ■
```

## 7. Write the file PLAN.IOM to the Memory Card.

```
ftp> put PLAN.IOM ... File written  
200 PORT command successful.  
150 opening data connection for plan.iom (**IPAddress**port#**).  
226 Transfer complete.  
** bytes received in *.* seconds (**bytes/s)  
ftp> ■
```

## 8. End FTP.

```
ftp> bye ... FTP ended.  
221 Goodbye.  
$ ■
```



# SECTION 12

## Automatic Clock Adjustment Function

This section provides an overview of the automatic clock adjustment function, including details on specifications, required settings, operations from CX-Programmer, and troubleshooting.

12-1	Automatic Clock Adjustment . . . . .	326
12-1-1	Overview. . . . .	326
12-1-2	Specifications . . . . .	327
12-2	Using the Automatic Clock Adjustment Function . . . . .	327
12-2-1	Procedure . . . . .	327
12-2-2	Settings Required for Automatic Clock Adjustment Function. . . . .	328
12-2-3	Auto Adjust Time . . . . .	329
12-3	Automatic Clock Adjustment Switch . . . . .	330
12-4	Automatic Clock Adjustment Error Processing . . . . .	330
12-4-1	Automatic Clock Adjustment (SNTP) Errors. . . . .	330
12-4-2	Error Log Error Codes for the Automatic Clock Adjustment Function	330

# 12-1 Automatic Clock Adjustment

## 12-1-1 Overview

The EtherNet/IP Unit or built-in EtherNet/IP port can obtain the clock information from the SNTP server (see note 1) at a particular time or when a designated bit turns ON and then refresh the internal clock information of the CPU Unit to which it is mounted (referred to as the local CPU Unit).

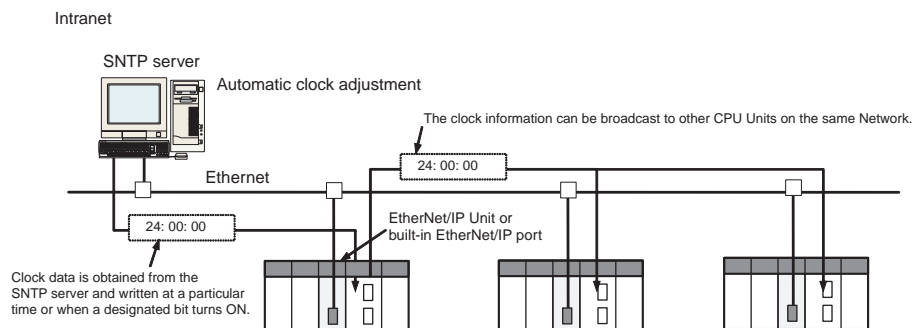

- Note**
- (1) The SNTP (Simple Network Time Protocol) server is used to control the time on the LAN.
  - (2) An error will occur in the following CPU Units when the automatic clock adjustment function is executed under the conditions shown in the table.

CPU Unit	Conditions
CPU Units manufactured on or before January 31, 2003 (lot numbers 030131 or earlier): CJ1G-CPU□□H CJ1H-CPU□□H CS1G-CPU□□H CS1H-CPU□□H	When the CPU execution mode is set to other than normal mode (priority peripheral servicing mode, parallel processing with synchronous memory access mode, or parallel processing with asynchronous memory access mode). AND When the CPU Unit operating mode is set to RUN or MONITOR mode.

- (3) The manufacturing date can be determined from the lot number on the side or top corner of the CPU Unit.
- (4) The lot numbers are as follows:  
 YYMMDDnnnn, in which YY indicates the last two digits of the year, MM the month, DD the day, and nnnn the serial number.
- (5) In accordance with SNTP protocol specifications, automatic adjustment will not be possible from February 7, 2036. In EtherNet/IP Units or built-in EtherNet/IP ports, this function will no longer operate from February 7, 2036 (an error message will not be displayed).

## 12-1-2 Specifications

Item	Specification	
Protocol	SNTP	
Port number	123 (UDP) Can also be set from the CX-Programmer in the Unit Setup.	
Adjustment timing	Automatic (fixed time) and manual (manual only cannot be set)	
Access to SNTP server	Writes the clock information from the SNTP server to the local CPU Unit.	Obtains the clock information from the SNTP server set up on the Network, and applies the information obtained to the local CPU Unit.
Refresh timing	When the automatic clock adjustment switch is turned from OFF to ON and at a specified time.	

## 12-2 Using the Automatic Clock Adjustment Function

### 12-2-1 Procedure

- 1,2,3...**
1. Make the basic settings.  
Refer to *Initial Settings* on page 34.
  2. With the CX-Programmer online, right-click the EtherNet/IP Unit or built-in EtherNet/IP port in the IO Table Dialog Box of the CX-Programmer, and select **Edit - Unit Setup** Set the following on the Auto Adjust Time Tab Page of the Edit Parameters Dialog Box.
    - SNTP server specification (required)
    - Access to the SNTP server is enabled when writing clock information from the SNTP server to the local CPU Unit when the Automatic Clock Adjustment Switch is turned from OFF to ON and at a set automatic adjustment time.
    - Automatic clock adjustment setting.
  3. To perform automatic clock adjustment manually, turn the Automatic Clock Adjustment Switch from OFF to ON. (The Automatic Clock Adjustment Switch is word n bit 05 in the words allocated in the CPU Bus Unit Area, where  $n = \text{CIO } 1500 + (25 \times \text{unit number})$ .)
  4. Select **Transfer to PLC** from the PLC Menu and click the **Yes** Button. The Unit Setup (CPU Bus System Setup) will be transferred to the CPU Unit (the setting data will be transferred to the CPU Bus Unit System Setup Area).

## 12-2-2 Settings Required for Automatic Clock Adjustment Function

The following settings must be set in the Unit Setup when using the automatic clock adjustment function.

CX-Programmer tab	Settings	Setting conditions	Reference
Auto Adjust Time	Server specification type	Required.	12-2-3 <i>Auto Adjust Time</i> on page 329
	IP Address	One or the other is required, depending on the <i>Server specification type</i> setting.	
	Host name		
	Port No.	Rarely required. (Change when a setting other than the default setting of 123 is required.)	
	Get the time information from the SNTP server	Required.	
	Auto Adjust Time	Optional	
	Retry timer	Optional (Change when the default setting of 10 seconds is unacceptable.)	
	Adjust Time	Optional	
DNS (See note.)	IP Address	Required.	3-8 <i>TCP/IP and Link Settings</i> on page 52
	Port No.	Rarely required. (Change when a setting other than the default setting of 53 is required.)	
	Retry timer	Optional (Change when the default setting of 10 seconds is unacceptable.)	

**Note** When the *Server specification type* field in Auto Adjust Time Tab is set to *Host name*.

### 12-2-3 Auto Adjust Time

The contents in the CPU Bus Unit System Setup that are set for using mail send and receive functions are shown in the CX-Programmer's Edit Parameters Dialog Box.

Item	Contents	Default
Get the time information from the SNTP server	Enable to set the CPU Unit's clock to the time at the SNTP server's clock. The clock can be changed only for the CPU Unit to which the EtherNet/IP Unit or built-in EtherNet/IP port is mounted.	Not selected (disabled)
Auto Adjust Time	Set the time at which the SNTP server is to be accessed to synchronize the clocks. When the time that is set here arrives, the SNTP server is accessed and the CPU Unit clock is adjusted to match the SNTP server clock.	0:0:0
Server specification type	Select whether the SNTP server used for automatic clock adjustment is to be specified by IP address or by host domain name (i.e., by host name).	IP Address
IP Address	Set the IP address for the SNTP server that is to be used for automatic clock adjustment. This setting is enabled only when server specification by IP address has been selected.	0.0.0.0
Host name	Set the host domain name (i.e., the host name) for the SNTP server that is to be used for automatic clock adjustment. This setting is enabled only when server specification by host name has been selected.	None
Port No.	Set the port number for connecting to the SNTP server that is to be used for automatic clock adjustment. This setting does not normally need to be changed.	0 (Number 123 is used.)

Item	Contents	Default
Retry timer	Set the time to elapse before retrying when a connection to the SNTP server fails. This setting does not normally need to be changed.	0 (10 s)
Adjust Time	This sets in the CPU Unit's clock data the time difference made up from the SNTP server's clock data. To use the clock data from the SNTP server just as it is, input 0.	+0:0

## 12-3 Automatic Clock Adjustment Switch

The Automatic Clock Adjustment Switch is allocated in the CIO Area as shown below. The first word  $n$  of the CIO Area is calculated using the following equation.

$$n = \text{CIO } 1500 + (25 \times \text{unit number})$$

The Unit control bit is shown in the following diagram.

**Automatic Clock Adjustment Switch (Bit 05 of  $n$ )**

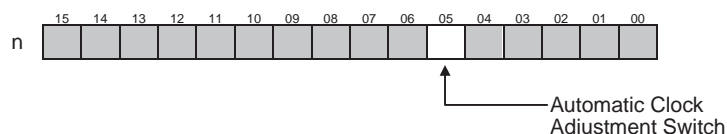

When the Automatic Clock Adjustment Switch turns from OFF to ON, the EtherNet/IP Unit or built-in EtherNet/IP port obtains the clock data from the SNTP server on the network, and applies it to the local CPU Unit. After applying the data, the switch automatically turns OFF again.

## 12-4 Automatic Clock Adjustment Error Processing

### 12-4-1 Automatic Clock Adjustment (SNTP) Errors

The following table shows the main causes and remedies for errors that occur in the automatic clock adjustment function (SNTP).

Cause	Correction
SNTP, DNS server address not set	Reset each server address (IP address or host name).
SNTP, DNS server communications time-out	Inspect the communications path (EtherNet/IP Unit or built-in EtherNet/IP port, cable connections, hub, router, server), and correct the situation that is causing the error.
CPU Unit internal clock could not be set	The automatic clock adjustment function is not supported by certain CPU Units (models, lot numbers) if they are in RUN or MONITOR mode.

### 12-4-2 Error Log Error Codes for the Automatic Clock Adjustment Function

When an error occurs while the EtherNet/IP Unit or built-in EtherNet/IP port is operating, the error code, detailed error code, and time the error occurred are saved in the error log. The following table provides a list of the error codes.

The error log can be read by sending FINS commands to the EtherNet/IP Unit or built-in EtherNet/IP port or by using the mail receive function and specifying the ErrorLogRead command.

Error code	Meaning	Detailed error code		Correction	EEPROM
		1st byte	2nd byte		
03C1	Server setting error	00H: DNS 03H: SNTP 04H: FTP 06H: BOOTP 07H: SNMP 08H: SNMP Trap 09H: FINS/UDP 0AH: FINS/TCP	01: IP address 02: Host name 03: Port number 04: Other parameters	Set the server settings correctly based on the information in the detailed error code.	---
03C4	Server connection error	00H: DNS 03H: SNTP 04H: FTP 06H: BOOTP 07H: SNMP 08H: SNMP Trap	01: Specified host does not exist 02: No service at specified host 03: Timeout 04: Closed unilaterally by host 05: Cannot connect because account information does not match 06: Host name resolution error 07: Transmission error 08: Reception error 09: Other error 0AH: Error in obtained IP address	Take either of the following measures. <ul style="list-style-type: none"> <li>• Correct the settings for each server.</li> <li>• Inspect the communications path (EtherNet/IP Unit or built-in EtherNet/IP port), cable connections, hub, router, server), and correct the situation that is causing the error.</li> </ul>	---
03C6	Clock data write error	0001: Clock data could not be refreshed because of a CPU Unit error.		Clear the CPU Unit error.	---
		0002: Clock data could not be refreshed because the CPU Unit could not write clock data in that operation mode.		The automatic clock adjustment function is not supported by certain CPU Units (models, lot numbers) if they are in RUN or MONITOR mode. (See note.)	---

- Note**
- (1) For details on other error log information, refer to the *Operation Manual, Construction of Networks: SECTION 14 Troubleshooting and Error Processing*.
- (2) An error will occur in the following CPU Units when the automatic clock adjustment function is executed under the conditions shown in the table.

CPU Unit	Conditions
CPU Units manufactured on or before January 31, 2003 (lot numbers 030131 or earlier): CJ1G-CPU□□H CJ1H-CPU□□H CS1G-CPU□□H CS1H-CPU□□H	When the CPU execution mode is set to other than normal mode (priority peripheral servicing mode, parallel processing with synchronous memory access mode, or parallel processing with asynchronous memory access mode). AND When the CPU Unit operating mode is set to RUN or MONITOR mode.

- (3) The manufacturing date can be determined from the lot number on the side or top corner of the CPU Unit.
- (4) The lot numbers are as follows:  
 YYMMDDnnnn, in which YY indicates the last two digits of the year, MM the month, DD the day, and nnnn the serial number.



# SECTION 13

## Maintenance and Unit Replacement

This section describes cleaning, inspection, and Unit replacement procedures, as well as the Simple Backup Function.

- 13-1 Maintenance and Replacement ..... 334
  - 13-1-1 Cleaning ..... 334
  - 13-1-2 Inspection ..... 334
  - 13-1-3 Unit Replacement Procedure ..... 334
- 13-2 Simple Backup Function..... 335
- 13-3 Using the Backup Tool ..... 338

## 13-1 Maintenance and Replacement

This section describes the routine cleaning and inspection recommended as regular maintenance, as well as the Unit replacement procedure required if an EtherNet/IP Unit needs to be replaced.

### 13-1-1 Cleaning

Clean the EtherNet/IP Unit regularly as described below in order to keep the network in its optimal operating condition.

- Wipe the Unit daily with a dry, soft cloth.
- When a spot can't be removed with a dry cloth, dampen the cloth with a neutral cleanser (2% solution), wring out the cloth, and wipe the Unit.
- A smudge may remain on the Unit from gum, vinyl, or tape that was left on for a long time. Remove the smudge when cleaning.

**⚠ Caution** Never use volatile solvents such as paint thinner, benzene, or chemical wipes. These substances could damage the surface of the Unit.

### 13-1-2 Inspection

Be sure to inspect the system periodically to keep it in its optimal operating condition. In general, inspect the system once every 6 to 12 months, but inspect more frequently if the system is used with high temperature or humidity or under dirty/dusty conditions.

#### Inspection Equipment

Prepare the following equipment before inspecting the system.

#### **Normally Required Equipment**

Have a standard and Phillips-head screwdriver, multimeter, alcohol, and a clean cloth.

#### **Occasionally Required Equipment**

Depending on the system conditions, a synchroscope, oscilloscope, thermometer, or hygrometer (to measure humidity) might be needed.

#### Inspection Procedure

Check the items in the following table and correct any items that are below standard.

	Item	Standard	Inspection
Environmental conditions	Ambient and cabinet temperature	0 to 55°C	Thermometer
	Ambient and cabinet humidity	10 to 90% (with no condensation or icing)	Hygrometer
	Dust/dirt accumulation	None	Visual
Installation	Are the Units installed securely?	No looseness	Phillips-head screwdriver
	Are the Ethernet cable connectors fully inserted and locked?	No looseness	Visual

### 13-1-3 Unit Replacement Procedure

Replace a faulty EtherNet/IP Unit as soon as possible. If the built-in EtherNet/IP port is faulty, replace the CPU Unit as soon as possible. We recommend having spare Units available to restore network operation as quickly as possible.

#### Precautions

Observe the following precautions when replacing a faulty Unit.

- After replacement, verify that there are no errors with the new Unit.
- When a Unit is being returned for repair, attach a sheet of paper detailing the problem and return the Unit to your OMRON dealer.

- If there is a faulty contact, try wiping the contact with a clean, lint-free cloth dampened with alcohol.

**Note** To prevent electric shock when replacing a Unit, always stop communications in the network and turn OFF the power supplies to all of the nodes before removing the faulty Unit.

**Settings Required after Unit Replacement**

After a Unit has been replaced, verify that the following steps have been made correctly.

- Set the node address and unit number.
- Connect the Ethernet cable.
- Set the configuration data (parameter settings) again and download them.

## 13-2 Simple Backup Function

### Overview

The simple backup function can be used to back up not only all of the data in the CPU Unit, but also all of the data stored in memory in the EtherNet/IP Unit or data for the built-in EtherNet/IP port. All of this data will automatically be backed up to the Memory Card.

The simple backup function can be used for the following EtherNet/IP Units and built-in EtherNet/IP port.

- CS-series EtherNet/IP Unit (CS1W-EIP21) mounted to a CS1D/CS1-H CPU Unit
- CJ-series EtherNet/IP Unit (CJ1W-EIP21) mounted to a CJ1-H/CJ1M/CJ2H-CPU□□-EIP CPU Unit
- A built-in EtherNet/IP port on a CJ2H-CPU□□-EIP/CJ2M-CPU3□ CPU Unit

When the EtherNet/IP Unit's setup data is written to the Memory Card using a simple backup operation, it is stored in the Memory Card as a Unit/Board backup file with the file name BACKUP□□.PRM. (The □□ digits in the backup file name indicate the unit address of the EtherNet/IP Unit or built-in EtherNet/IP port, which is the unit number + 10 hex.)

This backup file is also used when reading data from the Memory Card or comparing data with a file in the Memory Card.

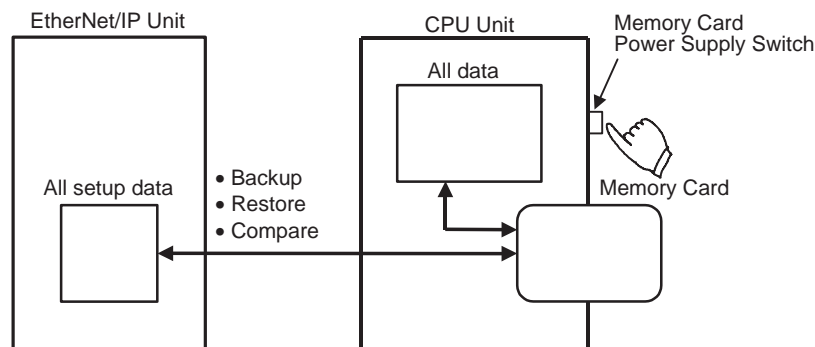

**Note** The following table shows the Units that support the simple backup function. Confirm that the Units being used support the function.

CPU Unit	EtherNet/IP Unit	
	CS1W-EIP21	CJ1W-EIP21
CS1D	Yes	---
CS1-H	Yes	---

CPU Unit	EtherNet/IP Unit	
	CS1W-EIP21	CJ1W-EIP21
CS1	No	---
CJ1-H	---	Yes
CJ1	---	No
CJ1M	---	Yes
CJ2H	---	Yes
CJ2M	---	Yes

## Applications

Use the simple backup function when creating a backup data file for the entire PLC (including the CPU Unit, EtherNet/IP Units, built-in EtherNet/IP port, and Serial Communications Units/Boards), or when replacing all the Units.

## Backup Sources and Restore Targets

The data that was backed up with the simple backup function can be restored to Units or built-in ports as shown in the following table. Network Configuration designations are given for the model numbers and versions of the backup sources and restore targets.

The model number must be the same for both the backup source and restore target. The CIP revision must be the same or higher.

Restore target Backup source	CS1W-EIP21 CJ1W-EIP21		CJ2B-EIP21	CJ2M-EIP21	CJ2M-EIP21	CJ1W-EIP21 (CJ2)
	Rev. 1.01	Rev. 2.01	Rev. 2.01	Rev. 2.01	Rev. 2.02	Rev. 2.01
CS1W-EIP21, CJ1W-EIP21 Rev. 1.01	Yes	Yes (See note 1.)	No	No	No	No
CS1W-EIP21, CJ1W-EIP21 Rev. 2.01	No	Yes	No	No	No	No
CJ2B-EIP21 Rev. 2.01	No	No	Yes	No	No	No
CJ2M-EIP21 Rev. 2.01	No	No	No	Yes	Yes	No
CJ2M-CIP21 Rev. 2.02	No	No	No	No	Yes	No
CJ1W-EIP21 (CJ2) Rev. 2.01	No	No	No	No	No	Yes

- Note**
- (1) Functions added for revision 2.1 will be set to their default settings. The number of settings will be increased, so an error will occur in the comparison after data is restored.
  - (2) Data backed up for revision 1.1 using a simple backup can be restored to an EtherNet/IP Unit or built-in EtherNet/IP port with revision 2.1, but an error will occur in the comparison. When changing the unit version, refer to 6-2-18 *Changing Devices* for information on the Network Configurator device change function.

## Operating Methods

### Backing Up EtherNet/IP Unit or Built-in EtherNet/IP Port Setup Files to the Memory Card

Set pins 7 and 8 of the DIP switch on the front panel of the CPU Unit as shown in the following table, and press the Memory Card Power Supply Switch for 3 seconds with the Memory Card inserted into the slot. Release the switch when the BUSY indicator lights.

DIP switch settings	
SW7	ON
SW8	OFF

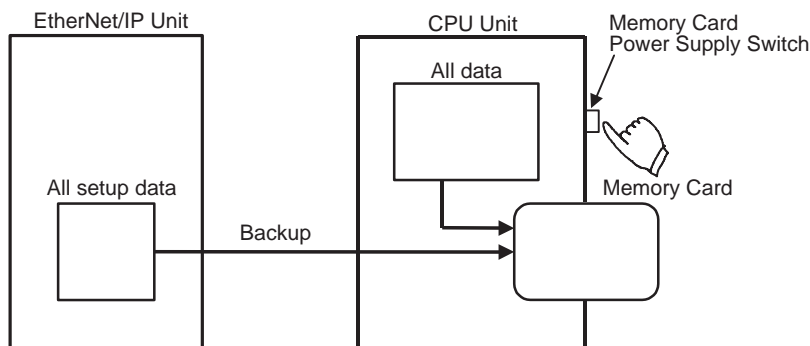

This operation will create an EtherNet/IP Unit or built-in EtherNet/IP port settings file, and write that file to the Memory Card along with the other backup files. When the Memory Card Power Supply Switch is pressed, the MCPWR indicator on the front of the CPU Unit will flash once and then remain lit while data is being written. If the data is written normally, the MCPWR indicator will turn OFF. The BUSY indicator will flash while the data is being written.

**Note** The backup operation will fail if it is performed after the device parameters were not downloaded successfully from the Network Configurator or CX-Programmer. Perform the backup operation only if the device parameters were downloaded normally.

**Restoring the EtherNet/IP Unit or Built-in EtherNet/IP Port Setup File from the Memory Card (Reading and Setting the Data in the Unit)**

Set pins 7 and 8 of the DIP switch on the front panel of the CPU Unit, as shown in the following table, and turn the power to the CPU Unit OFF and then ON again with the Memory Card inserted into the slot.

DIP switch settings	
SW7	ON
SW8	OFF

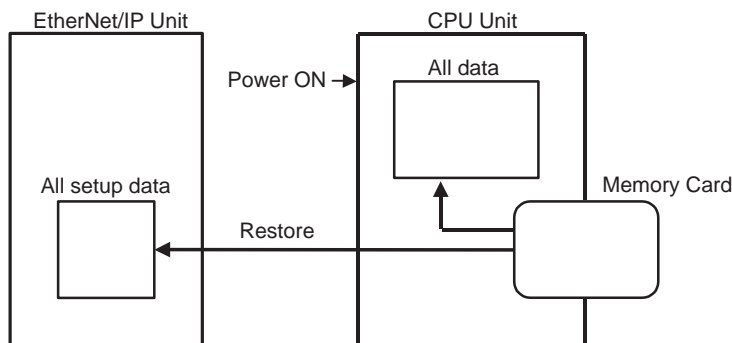

This operation will read the EtherNet/IP Unit or built-in EtherNet/IP port setup data file from the Memory Card and restore the data in the EtherNet/IP Unit or built-in EtherNet/IP port.

When the power supply is ON, the MCPWR indicator on the front of the CPU Unit will turn ON, flash once, and then remain lit while data is being read. The BUSY indicator will flash while data is being read. After the data has been read correctly, the MCPWR and BUSY indicators will turn OFF. If the MCPWR indicator flashes five times or if only the BUSY indicator turns OFF, it means that an error has occurred.

**Note** If the restoration from the Memory Card fails, an “H8” error will be displayed on the 7-segment display on the front panel. If this happens, the data on the Memory Card may not be correct. Confirm that the backup operation was completed normally before performing the restore operation.

**Comparing EtherNet/IP Unit or Built-in EtherNet/IP Port Data with the Setup File in the Memory Card**

Set pins 7 and 8 of the DIP switch on the front panel of the CPU Unit, as shown in the following table, and press down the Memory Card Power Supply Switch for 3 seconds.

DIP switch settings	
SW7	OFF
SW8	OFF

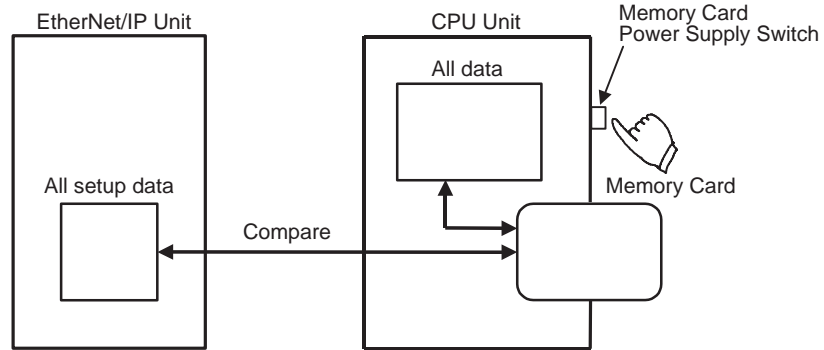

This operation will compare the data in the EtherNet/IP Unit or built-in EtherNet/IP port setup file in the Memory Card with the device parameters in the EtherNet/IP Unit or built-in EtherNet/IP port.

When the Memory Card Power Supply Switch is pressed, the MCPWR indicator on the front of the CPU Unit will flash once, and then remain lit while data is being compared. The BUSY indicator will flash while data is being compared. If the data matches, the MCPWR and BUSY indicators will turn OFF. If the MCPWR and BUSY indicators both flash, it means that the data does not match or that an error has occurred.

**Note** Data backed up for revision 1.1 using a simple backup can be restored to an EtherNet/IP Unit or built-in EtherNet/IP port with revision 2.1, but an error will occur in the comparison. When changing the unit version, refer to 6-2-18 *Changing Devices* for information on the Network Configurator device change function.

### 13-3 Using the Backup Tool

**Overview**

The PLC Backup Tool of the CX-Programmer can be used to back up, compare, and restore data for all Units or only specified Units in the PLC that is connected online.

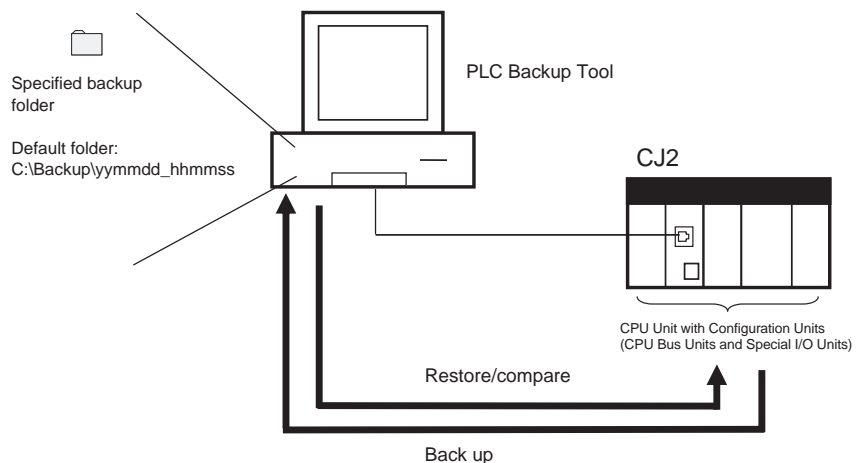

**Usage**

The PLC Backup Tool can be used for the following:

- Backing up all data in a PLC
- Comparing all of the data in a PLC with data that was previously backed up in the computer
- Using the restore function to transfer all of the PLC data to a system with the same configuration
- Transferring data to a new Unit after replacing a faulty Unit

**Procedure**

Select **PLC Backup Tool** from the CX-Programmer's Tool Menu. You can also select **OMRON - CX-One - CX-Programmer - PLC Backup Tool** from the Windows Start Menu.

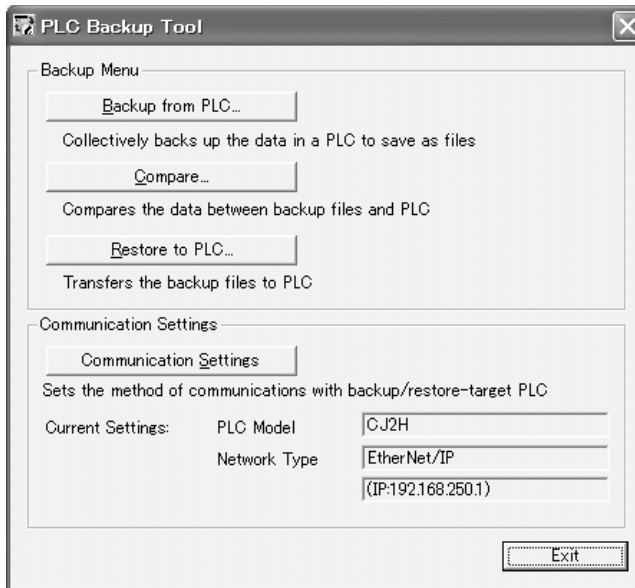

**Backup Menu**

Button	Function
Backup from PLC	Click this button to back up data. All of the data in the target PLC will be backed up to the computer.
Compare	Click this button to compare data. The data in the PLC can be compared to the data in a backup file or the data in two backup files can be compared. Any differences will be displayed.
Restore to PLC	Click this button to restore data. The data in a backup file will be transferred to the PLC to restore the status that existed when the data was backed up.

**Communications Settings**

Button	Function
Communications Settings	Click this button to set communications conditions for the target PLC. The current PLC model and network type will be displayed.

Refer to the *CX-Programmer Operation Manual* for detailed procedures.





# SECTION 14

## Troubleshooting and Error Processing

This section describes error processing, periodic maintenance operations, and troubleshooting procedures needed to keep the EtherNet/IP network operating properly. We recommend reading through the error processing procedures before operation so that operating errors can be identified and corrected more quickly.

14-1	Checking Status with the Network Configurator . . . . .	342
14-1-1	The Network Configurator's Device Monitor Function . . . . .	342
14-2	Using the LED Indicators and Display for Troubleshooting . . . . .	349
14-2-1	Errors Occurring at the EtherNet/IP Unit or Built-in EtherNet/IP Port . . . . .	349
14-3	Connection Status Codes and Error Processing . . . . .	360
14-4	Error Log Function . . . . .	366
14-4-1	Error Log Data Specifications . . . . .	366
14-4-2	Error Log Registration . . . . .	366
14-4-3	FINS Commands for Error Logs . . . . .	366
14-4-4	Error Log Error Codes . . . . .	367
14-5	Troubleshooting . . . . .	370
14-5-1	CPU Unit's ERR/ALM Indicator Lit or Flashing . . . . .	370
14-5-2	General Ethernet Problems . . . . .	371
14-5-3	Tag Data Links Fail to Start . . . . .	371
14-5-4	Tag Data Link Problems . . . . .	372
14-5-5	Message Timeout Problems . . . . .	373
14-6	Troubleshooting with FINS Response Codes . . . . .	373

## 14-1 Checking Status with the Network Configurator

### 14-1-1 The Network Configurator's Device Monitor Function

Connect the Network Configurator online, select the device to be checked, right-click to display the pop-up menu, and select **Monitor**.

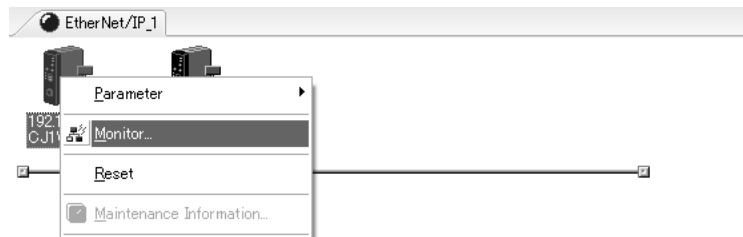

The Monitor Device Dialog Box will be displayed.

**Note** If a communications error occurs during monitoring, the dialog box will continue to show the last information that was collected. To start monitoring again, close the Monitor Device Dialog Box, and then open the dialog box again.

#### Status 1 Tab Page

The information displayed on the *Status 1* Tab Page shows the status of the flags in the following allocated CIO Area words: Unit status 1, Unit status 2, Communications status 1, Communications status 2, and Communications status 3. There will be a check mark in the box when the corresponding flag is ON.

In addition, the *Target Node Status* Field shows the connection status of the target nodes that are connected with the EtherNet/IP Unit as the tag data link originator. The icon will be blue if the connection is normal, or red if an error occurred.

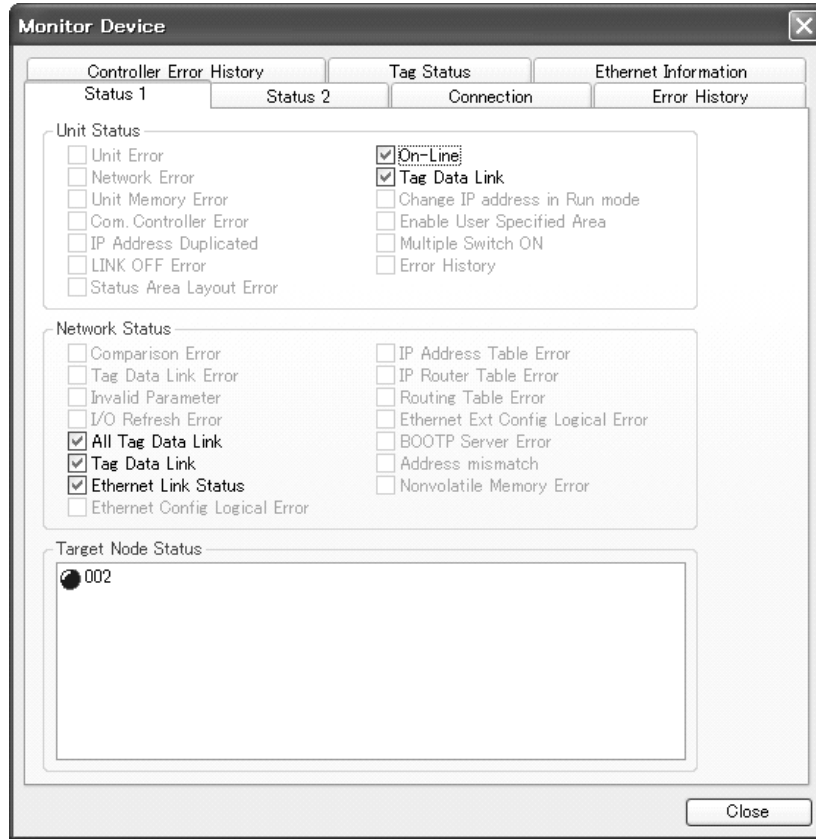

**Status 2 Tab Page**

The *Status 2* Tab Page's *Target PLC Status* Field shows the status of the target node PLCs that are connected with the EtherNet/IP Unit as the tag data link originator. The icon will be blue if the CPU Unit is in RUN mode or MONITOR mode, gray if it is in PROGRAM mode, or red if an error occurred.

The *Connected Status of FINS/TCP Connections* Field shows the status of FINS/TCP connections. There will be a check mark in the box when the corresponding connection is established (connected).

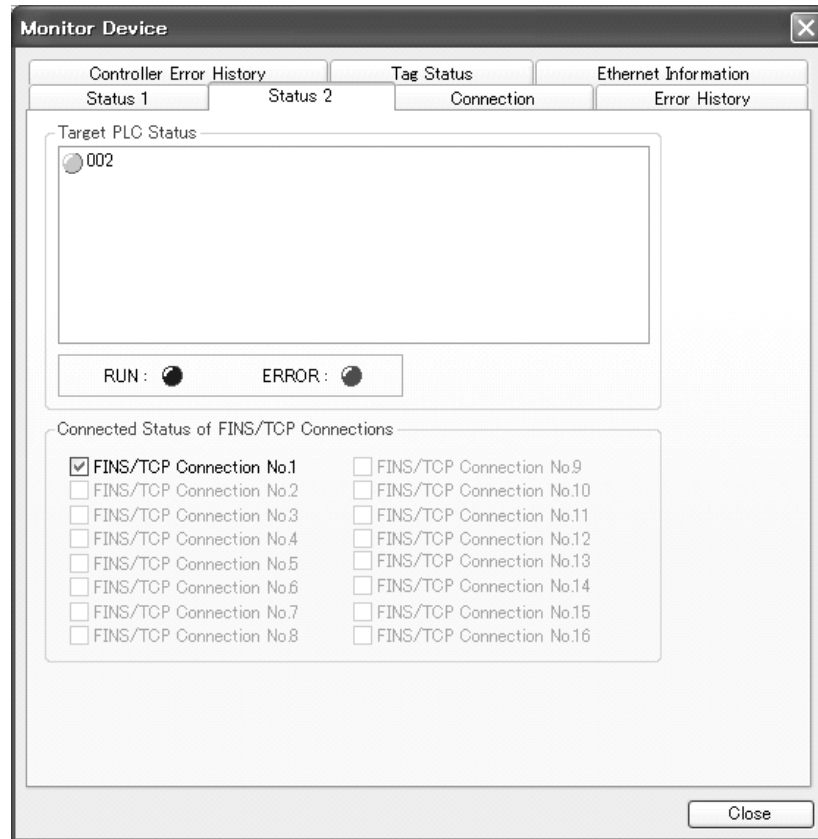

**Note** The target PLC status is can be used when the PLC status is selected for all the target sets for both originator and target connections. For those that are not selected, the status will be grayed-out.

Connection Tab Page

The *Connection* Tab Page's *Target Node Status* Field shows the connection status of the target nodes that are connected with the EtherNet/IP Unit as the tag data link originator. The icon will be blue if the connection is normal, or red if an error occurred.

In addition, the *Connection Status Area* shows the current status each connection that is set as the originator. This information can be used to identify the cause of tag data link errors. For details on the connection status, refer to *14-3 Connection Status Codes and Error Processing*.

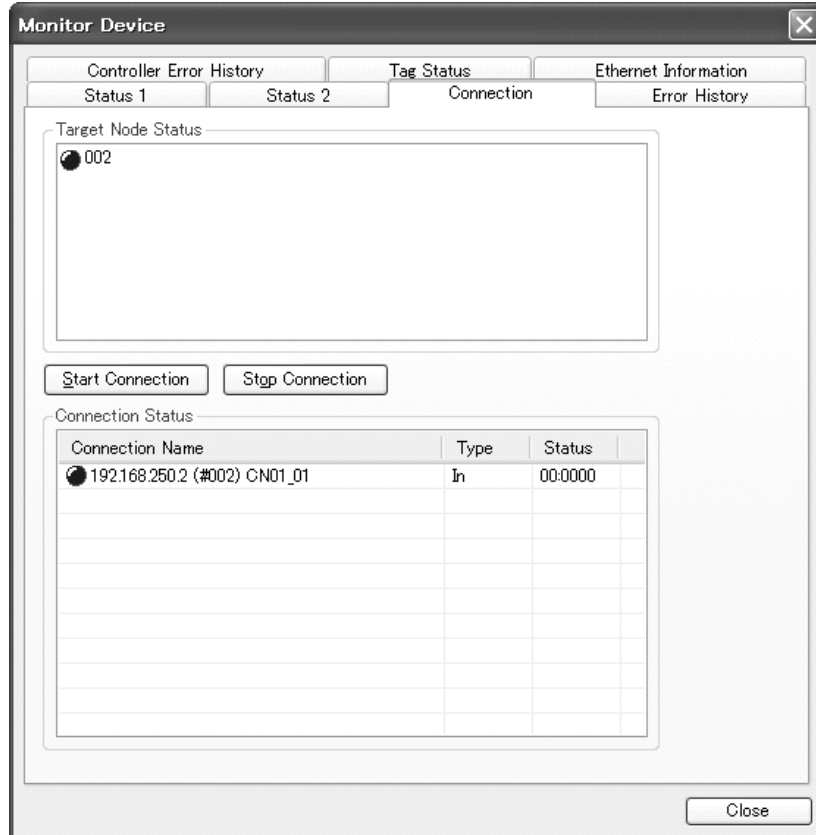

**Error History Tab Page**

The *Error History* Tab Page displays the error log stored in the EtherNet/IP Unit or built-in EtherNet/IP port. Errors that occurred in the past are recorded, and can be cleared or saved in a computer file as required.

In some cases, error records are cleared when the power is turned OFF, and in other cases the records are retained. For details on the error log, refer to *14-4 Error Log Function*.

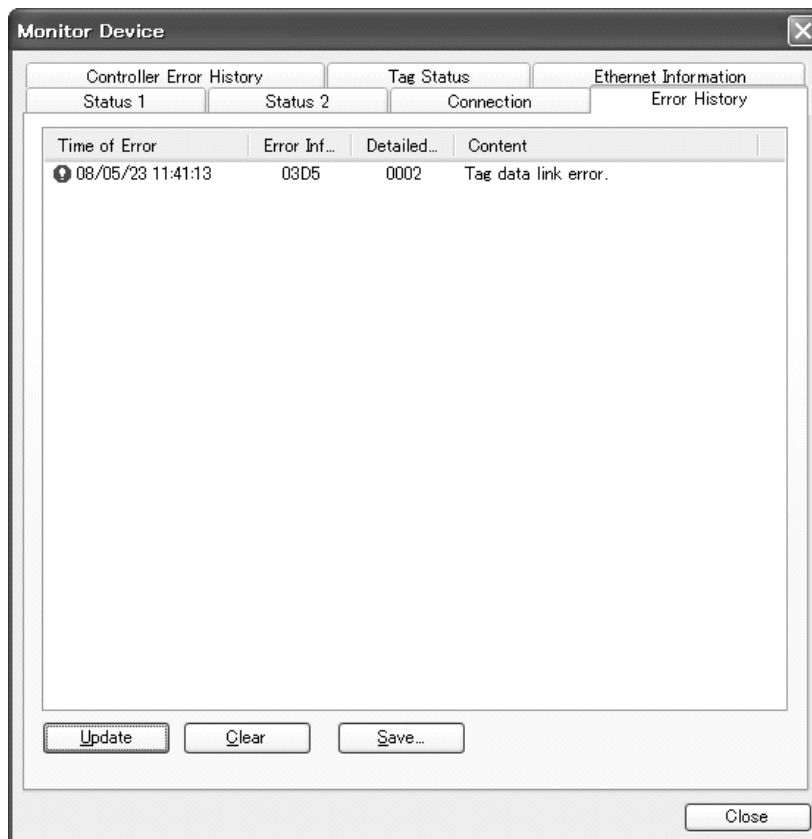

**Controller Error History Tab Page**

The error history of the CPU Unit for the EtherNet/IP Unit or built-in EtherNet/IP port is displayed on this tab page. The error history shows errors that have occurred. It can be cleared or saved in a file in the computer.

Refer to the operation manual of the CPU Unit for details on error information.

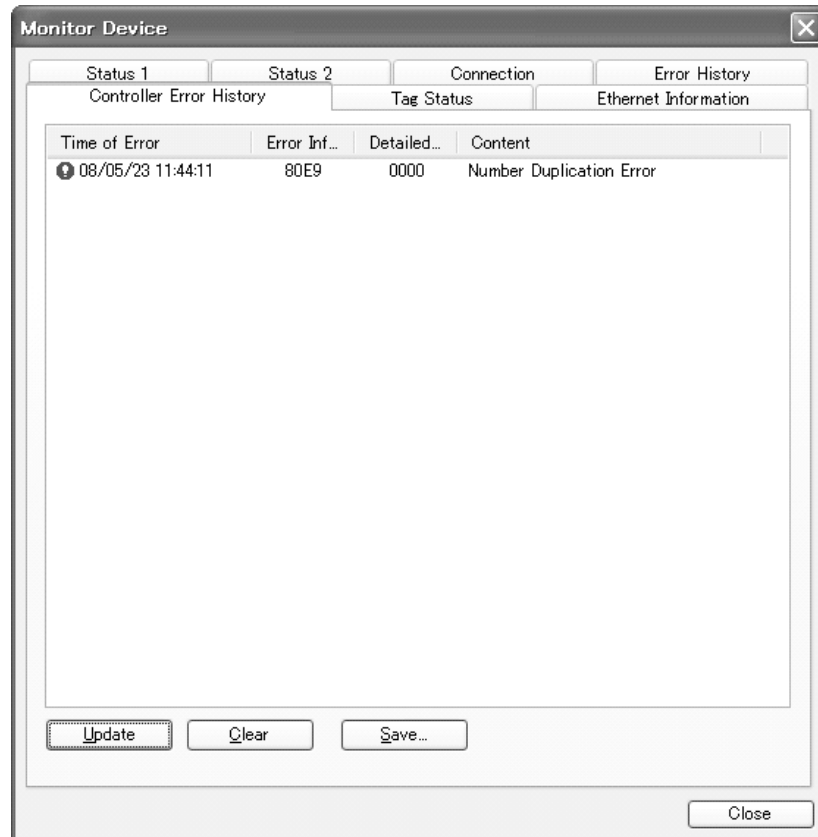

**Tag Status Tab Page**

This tab page shows if the tag settings for each tag for tag data links is set so that data can be exchanged with the CPU Unit. The following status is displayed.

- Ok: Data was exchanged normally.
- Processing to solve: The symbol or I/O memory address for the tag is being resolved. When the resolution is completed normally, a connection will be established and the data exchange will start.
- Area type error: The area (e.g., EM bank) specified by the tag setting does not exist in the CPU Unit. A connection will not be established for a tag for which this error occurs.
- Out of address range: The area specified by the tag setting is outside of the area address range in the CPU Unit. A connection will not be established for a tag for which this error occurs.
- Size error: Different sizes are set for the network symbol and the tag settings. Connections will not be opened for tags with this error.
- Not exist: A network symbol is not set in the symbol table in the CPU Unit for the specified tag setting. A connection will not be established for a tag for which this error occurs.
- PLC I/F error: There is a problem in the bus interface with the CPU Unit. Determine the cause based on the indicators and the error log.





**Ethernet Information Tab Page**

The *Ethernet Information* Tab Page shows the communications status at the communications driver level. The error counter information can be used to confirm whether communications problems have occurred. The tag data link information can be used to confirm characteristics such as the bandwidth usage (pps).

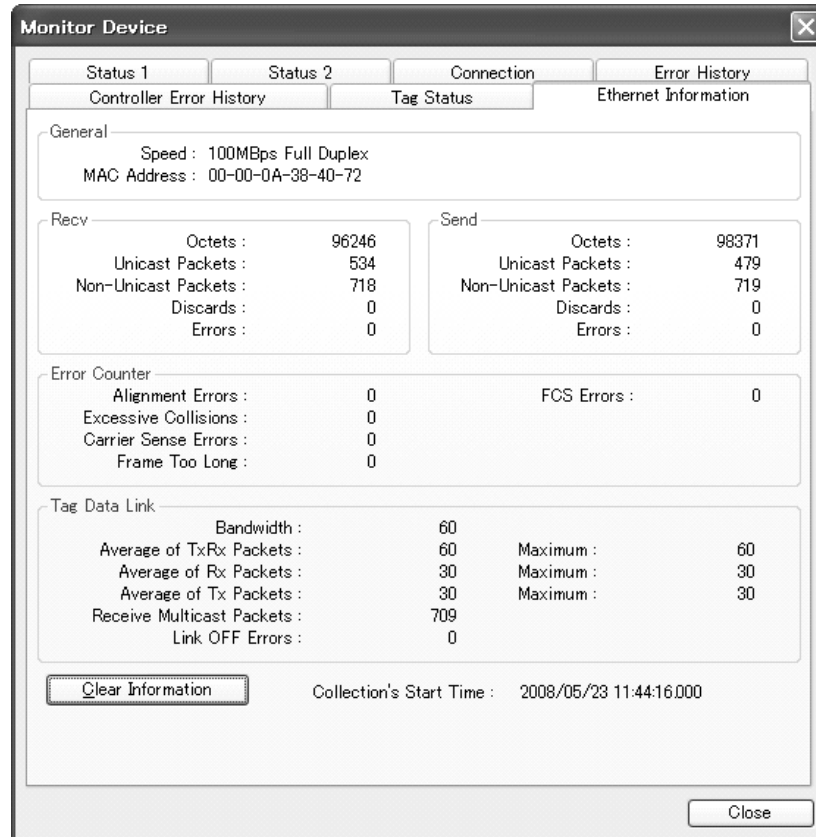
**14-2 Using the LED Indicators and Display for Troubleshooting****14-2-1 Errors Occurring at the EtherNet/IP Unit or Built-in EtherNet/IP Port****Errors Related to CPU Unit Data Exchange**

The 7-segment display alternates between the node address and error code.

Indicator			Error	Cause	Unit operation (Flag status)	Error log (hex)	Countermeasure
MS	NS	7-segment					
Flashing red	Not lit	H1	Duplicate unit number	The same unit number is set on another Unit.	Operation stops.	---	Set the unit numbers correctly and restart the EtherNet/IP Unit or built-in EtherNet/IP port.
Flashing red	Not lit	H2	CPU Unit faulty	---	Operation stops.	---	Replace the CPU Unit if the error recurs when the CPU Unit is restarted.

Indicator			Error	Cause	Unit operation (Flag status)	Error log (hex)	Countermeasure
MS	NS	7-segment					
Lit red	Not lit	H3	EtherNet/IP Unit or built-in EtherNet/IP port faulty	---	Operation stops.	---	Replace the EtherNet/IP Unit or (for a built-in EtherNet/IP port) the CPU Unit if the error recurs when the Unit is restarted.
Flashing red	Not lit	H4	Node address setting error	The node address set on the switches is invalid (00 or FF.)	Operation stops.	---	Set the node address correctly and restart the EtherNet/IP Unit or built-in EtherNet/IP port.
Flashing red	Not lit	H6	CPU Unit faulty	---	Records the error in the error log (time/date all zeroes). Operation stops.	000F	Replace the CPU Unit if the error recurs when the CPU Unit is restarted.
Flashing red	Not lit	H7	I/O table not registered	The CPU Unit's I/O table is not registered.	Operation stops.	0006	Create the I/O table.
Flashing red	---	H8	Simple backup function restore error	The simple backup function's data restoration failed.	The settings of the EtherNet/IP Unit or built-in EtherNet/IP port are all cleared, unless the backup file does not exist, a Memory Card is not mounted, or the PLC model does not match.	---	Perform the simple backup operation again. If the error recurs, replace the Memory Card, or EtherNet/IP Unit, or (for a built-in EtherNet/IP port) the CPU Unit.
Flashing red	---	H9	I/O bus error	An error occurred while exchanging data with the CPU Unit.	<ul style="list-style-type: none"> <li>If the Unit is the originator of the tag data link connection, it stops communications.</li> <li>If the Unit is the target of the tag data link connection and the PLC status is included in the communications data, the corresponding Target Node PLC Error Flag will be turned ON.</li> </ul>	000E	Check and correct the CPU Unit's operating environment.

Indicator			Error	Cause	Unit operation (Flag status)	Error log (hex)	Countermeasure
MS	NS	7-segment					
Flashing red	---	HA	CPU Unit memory error	A parity error occurred during an operation such as reading the routing tables.	Records the error in the error log. If the routing tables were being read, the routing tables are treated as missing.	0012	Register the routing tables in the CPU Unit again and restart the CPU Unit. Replace the CPU Unit if the error recurs.
				A memory error has occurred for the tag database in the CPU Unit (CJ2H/CJ2M CPU Unit only).	<ul style="list-style-type: none"> <li>If a symbol (tag name) is specified in the tag data link or Unit Status Area, refreshing the user-specified status area is stopped and tag data links will operate as follows: <ul style="list-style-type: none"> <li>Tag data link communications will be stopped for originator connections.</li> <li>Communications will continue for target connection. If PLC status is included in the communications data, the target node PLC error flag for the relevant target node will be turned ON.</li> </ul> </li> </ul> <p><b>Note</b> Recovery is possible from this error. If recovery is achieved, the tag data links will be restarted to return to normal status.</p>	0017	Download the tag data to the CPU Unit again. Replace the CPU Unit if the error recurs.
Flashing red	Not lit	Hb	CPU Unit event servicing timeout	A timeout occurred during an operation such as reading the routing tables to the CPU Unit.	Operation stops.	0011	Replace the EtherNet/IP Unit or (for a built-in EtherNet/IP port) the CPU Unit. if the error recurs when the Unit is restarted.
Flashing red	---	HC	Routing table error	There is a logic error in the routing table settings.	The Unit continues operating without the routing tables.	021A	Create the routing tables again.
Flashing red	---	Hd	I/O refresh error	The EM Area bank in which the device parameters were set was converted to file memory while the tag data link was operating.	Tag data is not refreshed if it is assigned to a non-existent area. <b>Note:</b> Recovery is possible for this error.	0347	Stop using the EM Area bank (in which the device parameters were set) as file memory, or correct the device parameters.

Indicator			Error	Cause	Unit operation (Flag status)	Error log (hex)	Countermeasure
MS	NS	7-segment					
Flashing red	---	HE	CPU Unit service monitoring error	<p>Servicing from the CPU Unit was not completed within the fixed interval. The monitoring time is normally 11 s.</p>	<ul style="list-style-type: none"> <li>• If the Unit is the originator of the tag data link connection, it stops communications.</li> <li>• If the Unit is the target of the tag data link connection and the PLC status is included in the communications data, the corresponding Target Node PLC Error Flag will be turned ON.</li> </ul> <p>Note: Recovery is possible for this error. When operation is restored, tag data link startup processing will be performed and operations will return to normal.</p>	0002	Check and correct the CPU Unit's operating environment.
Flashing red	---	HF	CPU Unit watchdog timer error	An error occurred in the CPU Unit.	<ul style="list-style-type: none"> <li>• If the Unit is the originator of the tag data link connection, it stops communications.</li> <li>• If the Unit is the target of the tag data link connection and the PLC status is included in the communications data, the corresponding Target Node PLC Error Flag will be turned ON.</li> </ul>	0001	Replace the CPU Unit.

**Errors Related to the CPU Unit** The 7-segment display alternates between the node address and error code.

Indicator			Error	Cause	Unit operation (Flag status)	Error log (hex)	Countermeasure
MS	NS	7-segment					
Flashing red	---	HH	CPU Unit Fatal Error	A fatal error occurred in the CPU Unit.	<ul style="list-style-type: none"> <li>If the Unit is the originator of the tag data link connection, it stops communications.</li> <li>If the Unit is the target of the tag data link connection and the PLC status is included in the communications data, the corresponding Target Node PLC Error Flag will be turned ON.</li> </ul>	0015	Eliminate the cause of the error in the CPU Unit. The tag data link will restart automatically when the cause of the error is eliminated.
---	---	---	Output OFF Error	An Output OFF (output inhibit) condition occurred in the CPU Unit.	The tag data link's send data will be cleared to 0 in accordance with the Output OFF settings, and data transfer will continue with that data.	---	Turn OFF the CPU Unit's Output OFF Bit (A50015). The tag data link's send data will be restored automatically when this bit is turned OFF.

**Errors Related to the Control Bits** The 7-segment display alternates between the node address and error code.

Indicator			Error	Cause	Unit operation (Flag status)	Error log (hex)	Countermeasure
MS	NS	7-segment					
---	---	C6	Multiple Switches ON	Two or more software switches were ON simultaneously, or a second software switch was turned ON before a prior operation was completed.	<p>The error code will be displayed on the 7-segment display for 30 seconds, and the Multiple Switches ON Error Flag (n+11, bit 14) will go ON.</p> <p>The error display will be cleared the next time that a settings operation is completed normally.</p>	---	Execute control bit operations one at a time.

**Errors Related to the Tag Data Links**      The 7-segment display alternates between the node address and error code.

Indicator			Error	Cause	Unit operation (Flag status)	Error log (hex)	Countermeasure
MS	NS	7-segment					
---	---	d5	Verification Error (target non-existent)	The target registered in the device parameters does not exist.	The Unit will periodically attempt to reconnect to the target. The Verification Error Flag (n+12, bit 00), Unit Error Occurred Flag (n+10, bit 00), and Network Error Occurred Flag (n+10, bit 01) will go ON.	--- Not recorded for version 2.0 or higher	Check the following items: <ul style="list-style-type: none"> <li>• Is the registered node's power supply ON?</li> <li>• Is the cable connected?</li> <li>• Is the cable damaged or loose?</li> <li>• Is there excessive noise?</li> </ul>
---	---	d6	Connection Failed	The connection could not be established because device parameters (such as the variable name and size) did not match in the originator and target, or connection resources are insufficient.	The Unit will periodically attempt to reconnect to the target. The Verification Error Flag (n+12, bit 00) and Unit Error Occurred Flag (n+10, bit 00) will go ON.	03D4	Correct the device parameter settings, and download the device parameters again from the Network Configurator.
---	---	d9	Tag Data Link Error	A timeout occurred in the tag data link. (Tag data was not received from the target within the specified timeout time.)	The Unit will periodically attempt to reconnect to the target where the error occurred. The Tag Data Link Error Flag (n+12, bit 02), Unit Error Occurred Flag (n+10, bit 00), and Network Error Occurred Flag (n+10, bit 01) will go ON.	03D5	Check the following items: <ul style="list-style-type: none"> <li>• Is the registered node's power supply ON?</li> <li>• Is the cable connected?</li> <li>• Is the cable damaged or loose?</li> <li>• Is there excessive noise?</li> </ul>

**Errors Related to Memory Access** The 7-segment display alternates between the node address and error code.

Indicator			Error	Cause	Unit operation (Flag status)	Error log (hex)	Countermeasure
MS	NS	7-segment					
Flashing red	---	E9	Memory Access Error	<p>An error occurred in the Unit's non-volatile memory itself. This error will occur in the following cases.</p> <ol style="list-style-type: none"> <li>1. An error occurred while writing the error log.</li> <li>2. An error occurred while writing the device parameters.</li> </ol> <p>Note: This error does not indicate checksum errors detected when reading data.</p>	<p>Case 1: The error record remains in RAM only. Subsequent writes to non-volatile memory are all ignored. Other than that, normal operation continues. (Error records continue to be written to RAM.)</p> <p>Case 2: Tag data links and message communications will continue operating.</p> <p>The Unit Error Occurred Flag (n+10, bit 00), Unit Memory Error Flag (n+10, bit 04), and Non-volatile Memory Error Flag (n+14, bit 15) will turn ON.</p>	0602	Download the Unit Setup from the tab pages of the Edit Parameters Dialog Box of the CX-Programmer and download the device parameters from the Network Configurator. If the error recurs, replace the Ethernet/IP Unit or (for a built-in EtherNet/IP port) the CPU Unit.

Indicator			Error	Cause	Unit operation (Flag status)	Error log (hex)	Countermeasure
MS	NS	7-segment					
Flashing red	---	E8	Device Parameters Error	The I/O Area set in the device parameters does not exist in the CPU Unit, or the EM Area was converted to file memory.	There is an error in the parameter settings stored in the Unit's non-volatile memory. (An error can occur when power is interrupted while data is being written to non-volatile memory.) The Unit Error Occurred Flag (n+10, bit 00) and Invalid Communications Parameter Flag (n+12, bit 04) will go ON.	021A	Download the Unit Setup from the tab pages of the Edit Parameters Dialog Box of the CX-Programmer and download the device parameters from the Network Configurator. If the error recurs, replace the EtherNet/IP Unit or (for a built-in EtherNet/IP port) the CPU Unit.  If the ladder program uses the OUT instruction to turn ON the CPU Bus Unit Restart Bit, change the OUT instruction to the SET instruction and download the parameters again.
				A checksum error or logic error was detected in the parameters.			
				The Unit was mounted to a different PLC (e.g., from CJ1 to CJ2) after the Unit settings were made.			
Flashing red	---	EA	IP Advanced Settings Error			03D1	Identify the error log data, correct the settings, and then download the Unit Setup from the tab pages of the Edit Parameters Dialog Box of the CX-Programmer
Flashing red	---	F2	Ethernet Basic Settings Error			03D0	Download the settings from the TCP/IP or Ethernet Tab Pages of the Edit Parameters Dialog Box of the CX-Programmer or download the TCP/IP settings from the Network Configurator.



## Errors Related to the Network

The 7-segment display alternates between the node address and error code.

Indicator			Error	Cause	Unit operation (Flag status)	Error log (hex)	Countermeasure
MS	NS	7-segment					
---	---	E1	Ethernet Link Not Detected	<p>The link with the switching hub could not be detected.</p> <p><b>Note</b> This error will not occur when data links are not set for version 2.0 or higher.</p>	<ul style="list-style-type: none"> <li>• The Unit will be offline and unable to communicate. Errors will be returned to all communications requests.</li> <li>• Data exchanges (refreshing) will continue with the CPU Unit.</li> </ul> <p>The Unit Error Occurred Flag (n+10, bit 00), Network Error Occurred Flag (n+10, bit 01), and Link OFF Error Flag (n+10, bit 09) will go ON. The Link Status Flag (n+13, bit 14) will go OFF.</p>	03D3	<p>Check the following items:</p> <ul style="list-style-type: none"> <li>• Is the cable connected?</li> <li>• Is the cable damaged or loose?</li> <li>• Is there excessive noise?</li> </ul>

Indicator			Error	Cause	Unit operation (Flag status)	Error log (hex)	Countermeasure
MS	NS	7-segment					
---	---	E3	Server Connection Error	An error occurred in communications with the DNS server.	The DNS Server Error Flag (n+14, bit 05) will turn ON.	03C4 De- tails: 00xx	Perform one of the following: <ul style="list-style-type: none"> <li>• Correct the DNS server settings.</li> <li>• Check the communications path (EtherNet/IP Unit or built-in EtherNet/IP port, cable connections, hubs, routers, and servers) and correct any problems.</li> </ul>
				An error occurred with the BOOTP server. <ol style="list-style-type: none"> <li>1. There was no response from the BOOTP server.</li> <li>2. The BOOTP server attempted to set an invalid IP address in the EtherNet/IP Unit or built-in EtherNet/IP port.</li> </ol>	Case 1: The Unit will continue sending requests to the BOOTP server until there is a response. In the meantime, the Unit will be offline and unable to communicate. Errors will be returned to all communications requests. Data exchanges (refreshing) will continue with the CPU Unit. Case 2: The Unit will operate with the default IP address (192.168.250.node_address). The Unit Error Occurred Flag (n+10, bit 00), Network Error Occurred Flag (n+10, bit 01), and BOOTP Server Error Flag (n+14, bit 10) will go ON.	03C4 De- tails: 06xx	Perform one of the following: <ul style="list-style-type: none"> <li>• Correct the BOOTP server settings.</li> <li>• Check the communications path (EtherNet/IP Unit or built-in EtherNet/IP port, cable connections, hubs, routers, and servers) and correct any problems.</li> </ul>
				An error occurred in communications with the STNP server.	The STNP Server Error Flag (n+14, bit 11) will turn ON.	03C4 De- tails: 03xx	Perform one of the following: <ul style="list-style-type: none"> <li>• Correct the STNP server settings.</li> <li>• Check the communications path (EtherNet/IP Unit or built-in EtherNet/IP port, cable connections, hubs, routers, and servers) and correct any problems.</li> </ul>

Indicator			Error	Cause	Unit operation (Flag status)	Error log (hex)	Countermeasure
MS	NS	7-segment					
---	---	E3	Server Connection Error	An error occurred in transmission to the SNMP trap.	---	03C4 De- tails: 07xx	Perform one of the following: <ul style="list-style-type: none"> <li>• Correct the SNMP trap settings.</li> <li>• Check the communications path (EtherNet/IP Unit or built-in EtherNet/IP port, cable connections, hubs, routers, and servers) and correct any problems.</li> </ul>
---	Lit red	F0	IP Address Duplication	The IP address of the EtherNet/IP Unit or built-in EtherNet/IP port is the same as the IP address set for another node.	<ul style="list-style-type: none"> <li>• The Unit will be offline and unable to communicate. Errors will be returned to all communications requests.</li> <li>• Data exchanges (refreshing) will continue with the CPU Unit.</li> </ul> <p>The Unit Error Occurred Flag (n+10, bit 00), Network Error Occurred Flag (n+10, bit 01), and IP Address Duplication Error Flag (n+10, bit 06) will go ON.</p>	0211	Check the IP addresses set on other nodes. Restart the EtherNet/IP Unit or built-in EtherNet/IP port after correcting the IP address settings to eliminate duplications.
Flashing red	---	F3	Address mismatch	The address conversion method was set for automatic generation, but the host ID of the local IP address does not match the FINS node address.	<ul style="list-style-type: none"> <li>• Operation will continue with the set IP address as the local IP address. The Address Mismatch Flag (n+14, bit 14) will turn ON.</li> </ul>	---	Check the IP address and the Node Address Setting Switch setting.

Indicator			Error	Cause	Unit operation (Flag status)	Error log (hex)	Countermeasure
MS	NS	7-segment					
Flashing red	Not lit	F4	Communications Controller Error	An error occurred in the Communications Controller in the EtherNet/IP Unit or built-in EtherNet/IP port.	<ul style="list-style-type: none"> <li>The Unit will be offline and unable to communicate. Errors will be returned to all communications requests.</li> <li>Data exchanges (refreshing) will continue with the CPU Unit.</li> </ul> The Unit Error Occurred Flag (n+10, bit 00), Network Error Occurred Flag (n+10, bit 01), and Communications Controller Error Flag (n+10, bit 05) will go ON.	020F	Replace the EtherNet/IP Unit or (for the built-in EtherNet/IP port) the CPU Unit if the error recurs when the Unit is restarted.
Flashing red	---	C8	Node Address Setting Changed During Operation	The Node Address Setting Switch was changed during operation.	Operation will continue. The IP Address Changed During Operation Flag (n+11, bit 02) will turn ON.	---	Restart the EtherNet/IP Unit or built-in EtherNet/IP port after setting the correct node address.

**Errors Related to the Unit** The 7-segment display alternates between the node address and error code.

Indicator			Error	Cause	Unit operation (Flag status)	Error log (hex)	Countermeasure
MS	NS	7-segment					
Lit red	Not lit	---	Special Unit Error	An error occurred in a Special I/O Unit or CPU Bus Unit.	Records the error in the error log. Operation stops.	0601	Restart the CPU Unit. Replace the EtherNet/IP Unit or (for the built-in EtherNet/IP port) the CPU Unit if the error recurs.

## 14-3 Connection Status Codes and Error Processing

This section explains how to identify and correct errors based on the tag data link's connection status. The connection status can be read using the *Connection* Tab Page of the Network Configurator's Monitor Device Window. For details, refer to *14-1-1 The Network Configurator's Device Monitor Function*.

- Note**
1. The connection status has the same meaning as the Connection Manager's General and Additional error response codes, as defined in the CIP specifications.
  2. The Open DeviceNet Vendor Association, Inc. (ODVA) can be contacted at the following address to obtain a copy of the CIP specifications.

ODVA Headquarters  
 4220 Varsity Drive, Suite A  
 Ann Arbor, Michigan 48108-5006  
 USA  
 TEL: 1 734-975-8840  
 FAX: 1 734-922-0027

Email [odva@odva.org](mailto:odva@odva.org)

WEB [www.odva.org](http://www.odva.org)

The following table shows the possible originator/target configurations.

Configuration	Originator	Target
Configuration 1	CS1W-EIP21, CJ1W-EIP21, CJ2H-CPU□□-EIP, CJ2M-CPU3□	CS1W-EIP21, CJ1W-EIP21, CJ2H-CPU□□-EIP, CJ2M-CPU3□
Configuration 2	CS1W-EIP21, CJ1W-EIP21, CJ2H-CPU□□-EIP, CJ2M-CPU3□	Other company's device
Configuration 3	Other company's device	CS1W-EIP21, CJ1W-EIP21, CJ2H-CPU□□-EIP, CJ2M-CPU3□

The following table shows the likely causes of the errors causes for each configuration and connection status (code).

Connection status		Source of error	Handling		
General Status (hex)	Additional Status (hex)		Configuration 1	Configuration 2	Configuration 3
00	0000	Normal status code: The connection has been opened and the tag data link is communicating normally.	---	---	---
01	0100	Error code returned from target: Attempted to open multiple connections at the same connection.	This error does not occur.	Depends on the target's specifications. (Contact the target device's manufacturer for details on preventing the error from occurring in the future.)	Depends on the originator's specifications. (Contact the originator device's manufacturer for details on preventing the error from occurring in the future.)
01	0103	Error code returned from target: Attempted to open a connection with an unsupported transport class.	This error does not occur.	Confirm that the target supports Class 1.	Confirm that the originator supports Class 1.
01	0106	Duplicate consumers: Attempted to open multiple connections for single-consumer data.	If the tag data link is stopped or started, this error may occur according to the timing, but the system will recover automatically.	Depends on the target's specifications. (Contact the target device's manufacturer.)	If the tag data link is stopped or started, this error may occur according to the timing, but the system will recover automatically.
01	0107	Error code returned from target: Attempted to close a connection, but that connection was already closed.	This error does not occur.	This error does not occur.	This is not an error because the connection is already closed.
01	0108	Error code returned from target: Attempted to open a connection with an unsupported connection type.	This error does not occur.	Check which connection types can be used by the target. (Contact the manufacturer.) Only multicast and point-to-point can be set.	Check which connection types can be used by the originator. (An error will occur if a connection other than multicast or point-to-point is set.)

Connection status		Source of error	Handling		
General Status (hex)	Additional Status (hex)		Configuration 1	Configuration 2	Configuration 3
01	0109	Error code returned from target: The connection size settings are different in the originator and target.	Check the connection sizes set in the originator and target.		
01	0110	Error code returned from target: The target was unable to open the connection, because of its operating status, such as downloading settings.	Check whether the tag data link is stopped at the target. (Restart the tag data link communications with the control bit.)	Depends on the target's specifications. (Contact the target device's manufacturer.)	Check whether the tag data link is stopped at the originator. (Restart the tag data link communications with the control bit.)
01	0111	Error code returned from target: The RPI was set to a value that exceeds the specifications.	This error does not occur.	Check the target's RPI setting specifications.	Set the originator's RPI setting to 10 seconds or less.
01	0113	Error code generated by originator or returned from target: Attempted to open more connections than allowed by the specifications (CJ2M-EIP21: 32, other CPU Units: 256).	Check the connection settings (number of connections) at the originator and target.	Check the connection settings (number of connections) at the originator and target. Check the connection specifications for another company's devices.	Check the connection settings (number of connections) at the originator and target. Check the connection specifications for another company's devices.
01	0114	Error code returned from target: The Vendor ID and Product Code did not match when opening connection.	This error does not occur.	Depends on the target's specifications. (Contact the target device's manufacturer.) Confirm that the target device's EDS file is correct.	Check the originator's connection settings.
01	0115	Error code returned from target: The Product Type did not match when opening connection.	This error does not occur.	Depends on the target's specifications. (Contact the target device's manufacturer.) Confirm that the target device's EDS file is correct.	Check the originator's connection settings.
01	0116	Error code returned from target: The Major/Minor Revisions did not match when opening connection.	Check the major and minor revisions set for the target device and connection. If necessary, obtain the EDS file and set it again.	Depends on the target's specifications. (Contact the target device's manufacturer.) Confirm that the target device's EDS file is correct.	Check the originator's connection settings.
01	0117	Error code returned from target: The tag set specified in the connection's target variables does not exist.	Check whether the originator and target tag sets and tags are set correctly. CJ2 CPU Units Only: Check symbol settings in the CPU Unit.	Depends on the target's specifications. (Contact the target device's manufacturer.)	Check the originator's connection settings. Check whether the target's tag sets and tags are set correctly. CJ2 CPU Units Only: Check symbol settings in the CPU Unit.

Connection status		Source of error	Handling		
General Status (hex)	Additional Status (hex)		Configuration 1	Configuration 2	Configuration 3
01	011A	Error code returned from originator: Connection could not be established because the buffer was full due to high traffic.	An unexpected network load may have been received. Use the Network Configurator Device Monitor or the Ethernet Tab Page to check the bandwidth usage, and correct the load. If there are places where broadcast storms occur, such as loop connections in the network connection format, then correct them.	An unexpected network load may have been received. Use the Network Configurator Device Monitor or the Ethernet Tab Page to check the bandwidth usage, and correct the load. If there are places where broadcast storms occur, such as loop connections in the network connection format, then correct them.	Follow the operating specifications for the originator. (Consult the originator manufacturer.)
01	011B	Error code returned from target: The RPI was set to a value that is below the specifications.	This error does not occur.	Depends on the target's specifications. (Contact the target device's manufacturer.)	Set the originator's RPI setting to 0.5 ms or greater.
01	0203	Error code returned from target: The connection timed out.	Tag data link communications from the target timed out. Check the power supply and cable wiring of the devices in the communications path, including the target and switches. If performance has dropped due to heavy load, change the performance settings. For example, increase the timeout time or RPI setting.		
01	0204	Error code returned from target: The connection-opening process timed out.	There was no response from the target. Check the power supply and cable wiring of the devices in the communications path, including the target and switches.		
01	0205	Error code returned from target: There was a parameter error in the frame used to open the connection.	This error does not occur.	Depends on the target's specifications. (Contact the target device's manufacturer.)	Depends on the originator's specifications. (Contact the originator device's manufacturer.)
01	0302	Error occurred at originator or error code returned from target: The tag data link's allowable bandwidth (pps) was exceeded.	Check the originator and target connection settings (number of connections and RPI).	Check the target's connection settings (number of connections and RPI).	Check the originator and target connection settings (number of connections and RPI).
01	0311	Error code returned from target: There was a parameter error in the frame used to open the connection.	This error does not occur.	Depends on the target's specifications. (Contact the target device's manufacturer.)	Depends on the originator's specifications. (Contact the originator device's manufacturer.)
01	0312	Error code returned from target: There was a parameter error in the frame used to open the connection.	This error does not occur.	Depends on the target's specifications. (Contact the target device's manufacturer.)	Depends on the originator's specifications. (Contact the originator device's manufacturer.)
01	0315	Error code returned from target: There was a parameter error in the frame used to open the connection.	This error does not occur.	Depends on the target's specifications. (Contact the target device's manufacturer.)	Depends on the originator's specifications. (Contact the originator device's manufacturer.)

Connection status		Source of error	Handling		
General Status (hex)	Additional Status (hex)		Configuration 1	Configuration 2	Configuration 3
01	0316	Error code returned from target: There was a parameter error in the frame used to close the connection.	This error does not occur.	Depends on the target's specifications. (Contact the target device's manufacturer.)	Depends on the originator's specifications. (Contact the originator device's manufacturer.)
01	031C	Error code generated in originator: Some other error occurred.	This error does not occur.	The originator generates this code when an unsupported response code is returned from the target in reply to a connection-opening request.	Depends on the originator's specifications. (Contact the originator device's manufacturer.)
08	---	Error code returned from target: There is no Forward Open or Large Forward Open service in the target device.	This error does not occur.	Depends on the target's specifications. (Contact the target device's manufacturer.)	Depends on the originator's specifications. (Contact the originator device's manufacturer.)
D0	0001	Error code generated in originator: The connection operation is stopped.	The connection was stopped because the Tag Data Link Stop Bit was turned ON, or the settings data is being downloaded.  Either turn ON the Tag Data Link Start Bit, or wait until the settings data has been downloaded.  Includes Controller stop errors, Unit failure, and EM bank files at the refresh destination. To handle these errors, refer to <i>14-2-1Errors Occurring at the EtherNet/IP Unit or built-in EtherNet/IP port.</i>	The meaning of this error code is defined by each vendor, so it depends on the target's specifications. (Contact the target device's manufacturer.)	Depends on the originator's specifications. (Contact the originator device's manufacturer.)
D0	0002	Error code generated in originator: The connection is being opened (opening processing in progress).	Wait until the opening processing is completed.	The meaning of this error code is defined by each vendor, so it depends on the target's specifications. (Contact the target device's manufacturer.)	Depends on the originator's specifications. (Contact the originator device's manufacturer.)



Connection status		Source of error	Handling		
General Status (hex)	Additional Status (hex)		Configuration 1	Configuration 2	Configuration 3
<b>Unique OMRON Error Codes</b>					
01	0810	<p>Error code returned from target: New data could not be obtained from the CPU Unit when opening connection. (The Unit will automatically retry, and attempt to open the connection again.)</p>	<p>This error may occur if the CPU Unit's cycle time was long when opening the connection, the specified EM bank was converted to file memory, or some problem in the PLC caused the PLC to stop.</p> <p>If the cycle time was too long, the problem will be resolved automatically. If the EM bank is set as file memory, change the storage location for the tag data. If the PLC has stopped, identify and correct the error.</p> <p>If the PLC system is stopped, identify the cause of the error from the CPU Unit error data.</p>	<p>The meaning of this error code is defined by each vendor, so it depends on the target's specifications. (Contact the target device's manufacturer.)</p>	<p>The meaning of this error code is defined by each vendor, so it depends on the originator's specifications. (Contact the originator device's manufacturer.)</p>
01	0811	<p>Error code generated in originator: New data could not be obtained from the CPU Unit when opening connection. (The Unit will automatically retry, and attempt to open the connection again.)</p>	<p>This error may occur if the CPU Unit's cycle time was long when opening the connection, or the specified EM bank was converted to file memory.</p> <p>If the cycle time was too long, the problem will be resolved automatically. If the EM bank is set as file memory, change the storage location for the tag data.</p>	<p>The meaning of this error code is defined by each vendor, so it depends on the target's specifications. (Contact the target device's manufacturer.)</p>	<p>The meaning of this error code is defined by each vendor, so it depends on the originator's specifications. (Contact the originator device's manufacturer.)</p>

## 14-4 Error Log Function

Errors detected by the EtherNet/IP Unit or built-in EtherNet/IP port are stored in the error log along with the date and time of their occurrence. The error log can be read and cleared from the Network Configurator.

Some error log records are cleared when the CPU Unit's power goes OFF, and other records are not cleared.

### 14-4-1 Error Log Data Specifications

Each error is recorded as one record in the error log.

Item	Specifications
Record length	10 bytes/record
Number of records	64 records max.
Data type	Binary (time information: BCD)

#### Structure of Each Record

Bit 15	Bit 00
<b>Error code</b>	
<b>Detail code</b>	
Minutes	Seconds
Day of month	Hour
Year	Month

### 14-4-2 Error Log Registration

#### Error Log Storage Area

When an error occurs, information on the error and the time stamp are stored in the Unit's internal RAM as an error log record. Serious errors are recorded in non-volatile EEPROM as well as RAM. The time read from the CPU Unit during cyclic servicing is used for the time stamp.

The error log records stored in EEPROM are copied to RAM when the Unit starts operating, so these records are retained even when the Unit's power is turned OFF or the Unit is restarted.

When the error log is read, the error log records in RAM are read. When the error log is cleared, the error log records in both RAM and EEPROM are erased.

#### Error Log Overflows

The error log can record up to 64 records. If another error occurs when the log is full, the oldest record will be erased to make room for the new error record.

#### Power Interruptions when Saving to EEPROM

If the power supply is interrupted or the Unit is restarted while the error log is being written to EEPROM, the error log may be corrupted. When the Unit starts, it performs a checksum test on the error log data read from EEPROM to detect corrupted data.

### 14-4-3 FINS Commands for Error Logs

The following FINS commands can be sent to the EtherNet/IP Unit or built-in EtherNet/IP port to read or clear the error log.

Command code		Function name
MRC	SRC	
21	02	ERROR LOG READ
	03	ERROR LOG CLEAR

For details, refer to *Appendix E FINS Commands Addressed to EtherNet/IP Units or Built-in EtherNet/IP Ports*.

## 14-4-4 Error Log Error Codes

Error code (hex)	Error	Detail code		Saved in EEPROM
		First byte	Second byte	
0001	CPU Unit watchdog timer error	00 hex	00 hex	Yes
0002	CPU Unit service monitoring error	Monitoring time (ms)		Yes
0006	Other CPU error	Bit D11: Unit not in Registered I/O Tables (Other bits are reserved for system use.)		Yes
000E	I/O bus error	00 hex	00 hex	Yes
000F	CPU Unit initialization error	00 hex	00 hex	Yes
0011	Event timed out	MRC (main command)	SRC (subcommand)	Yes
0012	CPU Unit memory error	01 hex: Read error 02 hex: Write error	03 hex: Routing tables 50 hex: CPU Bus Unit Area (CIO or DM)	Yes
0015	CPU Unit fatal error	00 hex	00 hex	Yes
0017	Tag database error	00 hex	00 hex	Yes
0103	Resend count exceeded (send failed)	FINS Command: Bit 15: OFF Bits 08 to 14: Source network address Bits 00 to 07: Source node address  FINS Response: Bit 15: ON Bits 08 to 14: Destination network address Bits 00 to 07: Destination node address  CIP Frame: FFFF		No
0105	Node address setting error (send failed)			No
0107	Remote node not in network (send failed)			No
0108	No Unit with specified unit address (send failed)			No
010B	CPU Unit error (send failed)			No
010D	Destination address not in routing tables (send failed)			No
010E	Not registered in routing tables (send failed)			No
010F	Routing table error (send failed)			No
0110	Too many relay points (send failed)			No
0111	Command too long (send failed)			No
0112	Header error (send failed)			No
0117	Internal buffers full; packet discarded			No
0118	Illegal packet discarded			No
0119	Local node busy (send failed)			No
0120	Unexpected routing error			No
0122	Service not supported in current mode; packet discarded	No		
0123	Internal send buffer full; packet discarded	No		
0124	Maximum frame size exceeded; routing failed	No		
0125	Response timeout; packet discarded	No		
020F	Communications controller error	00 hex	01 hex	Yes
0211	IP address duplication	Port number (always 02)	Lower byte of IP address	Yes
021A	Logic error in setting table	00 hex	02 hex: Network parameters 03 hex: Routing tables 04 hex: Unit Setup 0E hex: Unit name 12 hex: Status area layout setting error 13 hex: Status area layout setting verification error 15 hex: Installation in a PLC of another series (e.g., from CJ1 to CJ2) after setting the Unit.	Yes

Error code (hex)	Error	Detail code		Saved in EEPROM
		First byte	Second byte	
0300	Parameter error; packet discarded	FINS Command: Bit 15: OFF Bits 08 to 14: Source network address Bits 00 to 07: Source node address  FINS Response: Bit 15: ON Bits 08 to 14: Destination network address Bits 00 to 07: Destination node address  CIP Frame: FFFF		No
0347	I/O refreshing error	00 hex	00 hex	Yes
03C0	FINS/TCP setting error	01 to 10 hex: Connection number	01: Automatically allocated FINS node address duplication 02: Destination IP address error 03: Destination port number error	No
03C1	Server settings error	00 hex: DNS 03 hex: SNTP 04 hex: FTP 06 hex: BOOTP 07 hex: SNMP 08 hex: SNMP Trap 09 hex: FINS/UDP 0A hex: FINS/TCP	01: IP address 02: Host name 03: Port number 04: Other parameter	No
03C2	FINS/TCP packet discarded	01 to 10 hex: Connection number	02 hex: Reopening because remote node closed 03 hex: Reopening because of reception error 04 hex: Reopening because of transmission error 05 hex: Reopening because RST received from remote node 06 hex: Reopening because of no keep-alive response 07 hex: Illegal FINS/TCP procedure 08 hex: Insufficient memory during server processing 09 hex: Insufficient memory during client processing 0A hex: Insufficient memory during node switching	No
03C3	FINS/UDP packet discarded	00 hex	01 to FE hex: Source node address	No

Error code (hex)	Error	Detail code		Saved in EEPROM
		First byte	Second byte	
03C4	Server connection error	00 hex: DNS 03 hex: SNTP 04 hex: FTP 06 hex: BOOTP 07 hex: SNMP 08 hex: SNMP Trap	01 hex: Specified host does not exist 02 hex: No such service at specified host 03 hex: Timeout 06 hex: Host name resolution error 07 hex: Transmission error 08 hex: Reception error 09 hex: Other error 0A hex: Obtaining IP address error	No
03C6	Clock write error	0001: The clock time could not be updated because a error occurred in the CPU Unit.	Clear the error from the CPU Unit.	No
		0002: The clock time could not be updated because the CPU Unit or operating mode does not support this function.	Refer to <i>SECTION 12 Automatic Clock Adjustment Function</i> and check the application conditions.	
03D0	Ethernet basic setting error	01 hex: Ethernet setting error	01 hex: Checksum error 11 hex: Inconsistent settings 12 hex: Specified baud rate is not supported.	Yes
		02 hex: TCP/IP basic setting error	01 hex: Checksum error 11 hex: Invalid IP address 12 hex: Invalid subnet mask 13 hex: Invalid default gateway address 14 hex: Invalid primary name server 15 hex: Invalid secondary name server 16 hex: Invalid domain name 17 hex: Invalid host name	
03D1	Ethernet advanced setting error	02 hex: FINS setting error	01 hex: Checksum error 10 hex: Invalid IP router table 11 hex: Invalid FINS/UDP setting 12 hex: Invalid FINS/TCP setting 13 hex: Invalid FTP setting 14 hex: Invalid SNTP setting 15 hex: Invalid SNMP setting 16 hex: Invalid SNMP trap setting	Yes
03D2	Packet discarded.	01 hex	00 hex	No

Error code (hex)	Error	Detail code		Saved in EEPROM
		First byte	Second byte	
03D3	Link OFF error	00 hex	00 hex	No
03D4	Verification error (Tag data link only) <b>Note</b> For details on identifying the cause of the verification error, refer to <i>14-3 Connection Status Codes and Error Processing</i> . This error will not be stored when a target node is missing for version 2.0 or higher.	Connection instance number (0 to 255)	Lower byte of IP address	No
03D5	Tag data link error	00 hex	Lower byte of IP address	No
0601	CPU Bus Unit error	Variable		Yes
0602	CPU Bus Unit memory error	01: Read error 02: Write error	02 hex: Network parameter 06 hex: Error log 09 hex: Identity data 0E hex: Unit name 0F hex: Ethernet basic setting 10 hex: Ethernet advanced setting 11 hex: MAC address 12 hex: Status area layout setting 14 hex: Term Tag address resolution memory write error	Yes (See note.)

**Note** If a memory error occurs in the error log area of EEPROM, the record will not be stored in EEPROM.

## 14-5 Troubleshooting

### 14-5-1 CPU Unit's ERR/ALM Indicator Lit or Flashing

Use the following table to troubleshoot the system when the CPU Unit's ERR/ALM indicator is lit or flashing when the EtherNet/IP Unit or built-in EtherNet/IP port is mounted.

<b>An I/O verification error occurred.</b>	<ul style="list-style-type: none"> <li>• Confirm that the Unit is connected properly.</li> <li>• Check the I/O table with the I/O Table Verification operation and correct it if necessary. After correcting it, perform the I/O Table Create operation.</li> </ul>
<b>A CPU Bus Unit setting error occurred.</b>	<ul style="list-style-type: none"> <li>• The CPU Bus Unit model registered in the I/O tables does not match the model of CPU Bus Unit actually mounted. Check the I/O tables with the I/O Table Verification operation and correct it if necessary. After correcting the I/O tables, perform the I/O Table Create operation.</li> </ul>
<b>A CPU Bus error occurred.</b>	<ul style="list-style-type: none"> <li>• Confirm that the Unit is connected properly.</li> <li>• Restart the Unit. Replace the Unit if it doesn't restart.</li> </ul>
<b>An I/O Bus error occurred.</b>	<ul style="list-style-type: none"> <li>• Confirm that the Unit is connected properly.</li> <li>• Restart the Unit. Replace the Unit if it doesn't restart.</li> </ul>

For details, refer to the CPU Unit's Operation Manual.

### 14-5-2 General Ethernet Problems

<p><b>The 100M and 10M Indicators on the EtherNet/IP Unit or CPU Unit are both OFF.</b></p>	<ul style="list-style-type: none"> <li>• Confirm that the cable being used has the correct ratings.</li> <li>• Confirm that the cable is properly connected to the switching hub, and the hub's power supply is ON. (The 7-segment display will indicate error E1.)</li> <li>• If the switching hub's settings can be changed, confirm that the Ethernet link settings are the same as the settings for the EtherNet/IP Unit or built-in EtherNet/IP port. (For details, refer to <i>3-4 Network Installation</i>.)</li> </ul>
<p><b>The NS Indicator on the EtherNet/IP Unit or CPU Unit is lit red.</b></p>	<ul style="list-style-type: none"> <li>• Check whether the same IP address is set on another node. (The 7-segment display will indicate error F0.)</li> </ul>

### 14-5-3 Tag Data Links Fail to Start

Use the following table to troubleshoot tag data links when the Tag Data Links Operating Flag (bit 15 in Communications Status 1) does not go ON.

<p><b>The indicators on the EtherNet/IP Unit or CPU Unit are all OFF.</b></p>	<ul style="list-style-type: none"> <li>• Check whether power is being supplied to the PLC.</li> <li>• Check whether the EtherNet/IP Unit or built-in EtherNet/IP port is mounted in the Backplane correctly.</li> <li>• If a watchdog timer (WDT) error has occurred in the PLC, follow the procedures described in the PLC's Operation Manual to correct the problem.</li> <li>• All of the indicators for the EtherNet/IP Unit or built-in EtherNet/IP port will be OFF if a CPU Bus Unit error has occurred. Check for a CPU Bus Unit error.</li> <li>• Restart the Unit. Replace the Unit if it doesn't restart.</li> </ul>
<p><b>The MS indicator on the EtherNet/IP Unit or CPU Unit is lit green, but the NS indicator remains OFF.</b></p>	<ul style="list-style-type: none"> <li>• If the EtherNet/IP Unit's 7-segment display is displaying an error code, refer to the tables in <i>14-2 Using the LED Indicators and Display for Troubleshooting</i>.</li> <li>• Confirm that the cables are properly connected to the switching hub and the power supply to the switching hub is ON.</li> <li>• If data is being restored by the simple backup function, wait until the restore operation is completed.</li> </ul>
<p><b>The MS indicator on the EtherNet/IP Unit or CPU Unit is lit green, but the NS indicator continues to flash green.</b></p>	<ul style="list-style-type: none"> <li>• If the EtherNet/IP Unit's 7-segment display is displaying an error code, refer to the tables in <i>14-2 Using the LED Indicators and Display for Troubleshooting</i>.</li> <li>• The NS indicator will continue to flash green if the tag data link settings have not been set in the Unit. Use the Network Configurator to set the tag data link settings in the Unit, and then restart the Unit.</li> </ul>
<p><b>The MS indicators is lit green on the EtherNet/IP Unit or CPU Unit, but the NS indicator continues to flash red.</b></p>	<ul style="list-style-type: none"> <li>• Identify the error code shown on the 7-segment display based on the tables in <i>14-2 Using the LED Indicators and Display for Troubleshooting</i>, and eliminate the cause of the error.</li> </ul>

### 14-5-4 Tag Data Link Problems

<p><b>The tag data isn't simultaneous.</b></p>	<p>Observe the following precautions when writing application programs:</p> <ul style="list-style-type: none"> <li>• Maintain the simultaneity of data in connection-units between the PLC and EtherNet/IP Unit or built-in EtherNet/IP port.</li> <li>• If another company's device is being used, refer to that device's user's manual for details.</li> </ul>
<p><b>At startup, the received data is OFF unexpectedly.</b></p>	<ul style="list-style-type: none"> <li>• When received data is used in the ladder program, use the All Tag Data Links Operating Flag in Communications Status 1, or the Target Node PLC Operating Flag as a condition. If the Target Node PLC Operating Flag is used, the PLC status must be included in tag sets of both the sending and receiving nodes.</li> <li>• If the Output OFF function (Output Inhibit) is enabled in the output (produce) tag settings, all of the output data will be OFF if a fatal error occurs in the CPU Unit or the Output OFF Bit is turned ON. Check the status of the output (producer) PLC.</li> </ul>
<p><b>The tag data links start and stop communicating intermittently.</b></p>	<ul style="list-style-type: none"> <li>• Check whether the baud rate is set to 10 Mbps, or a 10M or 100M repeater hub is being used. The tag data link performance is based on the use of switching hubs. The bandwidth listed in the specifications (CJ2M-EIP21: 3,000 pps, other CPU Units: 6,000 pps) is achieved when the Unit auto-negotiates to full-duplex at 100 Mbps.</li> <li>• Refer to <i>14-1 Checking Status with the Network Configurator</i> for details on checking the error counters on the Monitor Device Window's <i>Ethernet Information</i> Tab Page. The error and discarded packet counters indicate problems such as noise in the communications path, the use of substandard cables, damaged cables/connectors, loose connectors, abnormally high communications load, or incorrect wiring (loops) in the switching hub wiring.</li> <li>• Contact the switching hub manufacturer to determine whether there are any problems with the transfer capacity of the switching hubs in the communications path. If switching hubs are arranged in a cascade connection, there may be a heavy load concentrated at a mid-level switching hub. In the EtherNet/IP Unit or built-in EtherNet/IP port itself, processing is performed with a higher priority than message communications, so specifications provide for a 3,000 pps bandwidth for the CJ2M-EIP21 and a 6,000 pps bandwidth for other CPU Units in tag data link performance only.</li> <li>• Refer to <i>14-1 Checking Status with the Network Configurator</i> for details on checking the connection status on the Monitor Device Window's <i>Connection</i> Tab Page. Eliminate any errors, which can be identified in the tables in <i>14-3 Connection Status Codes and Error Processing</i>.</li> </ul>



### 14-5-5 Message Timeout Problems

<p><b>Timeout errors occur frequently in message services (CIP UCMM, CIP Class 3, or FINS).</b></p>	<ul style="list-style-type: none"> <li>• When there is a high load in the tag data link, and the CPU Unit's cycle time is relatively long or there are messages coming in from many nodes, the message service response time may be delayed and messages may be discarded occasionally.</li> <li>• In this case, the communications load must be reduced by increasing (slowing) the tag data link's RPI, reducing the message load, or increasing the timeout value.</li> <li>• The tag data link's bandwidth usage can be checked on the Monitor Device Window's <i>Ethernet Information Tab Page</i>. Refer to <i>14-1 Checking Status with the Network Configurator</i> for details.</li> <li>• The error log error codes that indicate discarded messages (insufficient memory) due to heavy communications loads are 0117, 0119, 0123, 0125, 03C2 (detail code □□08, □□09, or □□0A), 03C3, and 03D2. Refer to <i>14-1 Checking Status with the Network Configurator</i> for details on reading the error codes on the <i>Error History Tab Page</i>.</li> <li>• For information on preventing high loads in FINS communications, refer to <i>8-7 Precautions on High Traffic in FINS Communications</i>.</li> </ul>
---	---

## 14-6 Troubleshooting with FINS Response Codes

The cause of errors that occur when using the SEND(090), RECV(098), or CMND(490) instructions can be identified from the response codes. (Refer to the description of *Communications Port Completion Codes* in *8-6-4 Writing Programs* for the storage locations of response codes generated by the SEND(090), RECV(098), or CMND(490) instructions.)

This section describes the completion codes produced by EtherNet/IP Units. For details on completion codes produced by CPU Units, other CPU Bus Units, or computers equipped with FINS services, refer to the device's operation manual.

The 6<sup>th</sup>, 7<sup>th</sup>, and 15<sup>th</sup> bits of the response codes have specific functions. The 6<sup>th</sup> bit will be ON when a non-fatal error has occurred in the PLC at the remote node; the 7<sup>th</sup> bit will be ON when a fatal error has occurred in the PLC at the remote node; and the 15<sup>th</sup> bit will be ON when a network relay error has occurred. The following table explains the meaning of the completion codes.

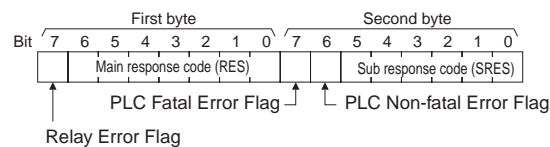

Main response code		Sub response code		Item to check	Likely cause	Corrective action
Value and meaning		Value and meaning				
00	Normal completion	00	---	---	---	---

Main response code		Sub response code		Item to check	Likely cause	Corrective action
Value and meaning		Value and meaning				
01	Local node error	03	Local node send error	---	Lack of available space in internal buffers	The load (traffic) on the Ethernet Unit is too heavy. Check your user applications.
		05	Node address setting error	Local IP address	The network cannot be used because the IP address setting is incorrect.	Correct the local IP address.
		07	Local node busy (send failed)	System load	Lack of available space in internal buffers	The load (traffic) on the Ethernet Unit is too heavy. Check your user applications.
02	Remote node error	01	Remote node not in network	IP address table and IP router table	IP address of remote node not set correctly.	Set IP address of remote node into IP address table and, if internetwork transmission is required, into the IP router table.
		02	No Unit with specified unit address	Instruction's control data	There is no Unit with the specified unit address.	Check the remote node's unit address.
		05	Response timeout	Transfer conditions (Use FINS status read commands.)	Message packet was corrupted by transmission error.	Increase the number of transmit retry attempts.
				Instruction's control data	The response monitoring time is too short.	Set a longer response monitoring time.
				Read the error log.	The transmission frame may be corrupted or the internal reception buffer full.	Read out the error log and correct the system as required.
03	Unit error (Controller error)	01	Communications controller error	Affected controller's ERC indicator	Error occurred in the communications controller.	Take corrective action, referring to troubleshooting procedures in this section.
		02	PLC error	Affected node's LED indicators	CPU Unit error occurred in the PLC at the remote node.	Clear the error in the CPU Unit. (Refer to the PLC's operation manuals.)
		04	Unit number setting error	Unit number	The unit number setting is incorrect.	Confirm that the unit number set on the switch is within the specified range and that the same unit number is not used twice in the same network.
04	Service not supported	01	Unsupported command	Command code	The specified command code is not supported by the destination Unit.	Check the command code.
				FINS header frame length	A short frame (4 bytes) is being used for the FINS header frame.	The EtherNet/IP Unit does not support short headers.
05	Routing error	01	Routing table setting error	Routing tables	Remote node is not set in the routing tables.	Set the destination address in the routing tables.
		02	Routing tables not registered	Routing tables	Destination is unknown because there are no routing tables.	Set routing tables at the local node, remote node, and any relay nodes.
		03	Routing table error	Routing tables	Routing table error	Set the routing tables correctly.
		04	Too many relay points	Network configuration	The maximum number of network levels (3) was exceeded in the command.	Redesign the network, or reconsider the routing tables to reduce the number of relay nodes in the command.

Main response code		Sub response code		Item to check	Likely cause	Corrective action
Value and meaning		Value and meaning				
10	Command format error	01	Command too long	Command data	The command is too long.	Check the command format of the command and set it correctly.
					The command exceeded 1,473 bytes when broadcasting.	
		02	Command too short	Command data	The command is too short.	
		03	Number of items does not match amount of data	Command data	The specified number of items does not match the amount of write data.	
		05	Header parameter error	Command data	Data for another node on the same network was received from the network.	Check the command format of the command and set it correctly.
					Attempted to send response data for a broadcast address.	
11	Parameter error	00	Parameter error	Parameters in command data	The specified parameters are incorrect.	Check the command data and set the parameters correctly.
					The UDP/TCP socket number was not within the proper range.	Be sure the socket number is between 1 and 8.
					The local UDP port number might be set to 0.	Set the local UDP port number correctly.
		01	No data area code	Variable type in command data	A correct memory area code has not been used or EM Area is not available.	Check the command's data area code in the Results Storage Area and set the appropriate code.
		03	Address out-of-range error	First word address in command data	The first word is in an inaccessible area.	Check the data area range, and set a first word that is in an accessible area.
					The specified bit number is not 00.	Check the command's data area code in the Results Storage Area. The bit address must be 00 for EtherNet/IP Units.
		04	Address range overflow	Command data	The address range specified in the command is not correct.	Set the address in the command data so that the start address plus the number of words does not exceed accessible memory.
		0B	Response too long	Command data	The response frame is longer than allowed.	Correct the number of data elements or other parameters in the command data for which the response is being returned.
0C	Parameter error	Parameters in command data	The specified parameters are incorrect.	Check the command data and set the parameters correctly.		
21	Cannot write	08	Cannot change	IP address conversion method	A FINS message was received from an IP address that differed from the ones in the Unit Setup with FINS node addresses that could not be dynamically changed.	Correct the relationships between IP addresses and FINS node addresses. Refer to <i>SECTION 5 Determining IP Addresses</i> for details.

Main response code		Sub response code		Item to check	Likely cause	Corrective action
Value and meaning		Value and meaning				
22	Status error (operating mode disagreement)	0F	Cannot execute because service is being processed.	Socket status area	The same socket service is already in progress at the specified socket number.	Use the corresponding socket status flag in PLC memory to be sure that socket service has finished before starting services again.
		10	Socket not open	Socket status area	The specified socket is not open.	Open the socket. (For TCP sockets, wait until the connection is made.)
		11	Local node busy (send failed)	System load	Lack of available space in internal buffers	The load (traffic) on the Ethernet Unit is too heavy. Check your user applications.
		20	FINS/TCP not connected	Unit Setup	Not opened due to system settings.	Correctly set the Unit Setup, FINS/TCP connection number, remote IP address, and remote port number.
		21			Not opened due to a change command from the FINS/TCP connection's remote node.	
		22			Closed by remote node; opening again.	
		23			Opening again because of a reception error.	
		24			Opening again because of a send error.	
		25			Opening again because of an RST response in keep-alive.	
		26			Opening again because there was no response in keep-alive.	
		30			Establishing connection	
		31	Cannot change connection	Unit Setup and command data	The specified connection number is not set as a FINS/TCP client in the Unit Setup.	Correct the settings for the Unit Setup, the FINS/TCP connection number, the remote IP address, and the remote port number.
		32	Cannot execute because service was interrupted	Command data	While a remote node change was being processed for the specified connection number, a request for a change was received and the processing was stopped.	Correct the settings for the FINS/TCP connection number, the remote IP address, and the remote port number.
23	No such Unit (Environment error)	05	Parameters	Unit Setup	IP address conversion failed.	Check the IP address and subnet mask in the Unit Setup, and correct if necessary.
		07	Configuration error	IP address conversion in Unit Setup	IP address conversion is set for automatic conversion only.	Check the IP address conversion setting in the Unit Setup. This error will be generated for the READ IP ADDRESS TABLE command only.

# Appendix A

## CS/CJ-series Ethernet Unit Function Comparison

Item	Support for function		
	Ethernet Unit	EtherNet/IP Unit or built-in EtherNet/IP port	
		Unit version 1.0	Unit version 2.0 or later
Tag data link communications service	No	Yes	Yes
CIP message communications service	No	Yes	Yes
FINS/UDP service	Yes	Yes	Yes
FINS/TCP service	Yes	Yes	Yes
Socket service	Yes	No	No
File transfer (FTP)	Yes	No	Yes
Mail send/receive	Yes	No	No
Web functions	Yes	No	No
Automatic adjustment of PLC's internal clock	Yes	No	Yes
Simple backup function	Yes	Yes	Yes
Error log	Yes	Yes	Yes
Response to PING command	Yes	Yes	Yes
SNMP/SNMP trap	No	No	Yes
CIDR function for IP addresses	No	No	Yes
Online connection by EtherNet/IP using CX-One	No	No	Yes
Online connection by Ethernet (FINS) using CX-One	Yes	Yes	Yes
Online connection by EtherNet/IP using Network Configurator	No	Yes	Yes



# Appendix B

## Ethernet Network Parameters

Parameter	Value	Description
TCP send buffer	4,096 bytes	Maximum capacity of the TCP send buffer
TCP receive buffer	4,096 bytes	Maximum capacity of the TCP receive buffer
UDP send buffer	9,000 bytes	Maximum capacity of the UDP send buffer
UDP receive buffer	9,016 bytes	Maximum capacity of the UDP receive buffer
FINS receive buffer	16,383 bytes	Maximum capacity of the FINS receive buffer
RAW send buffer	2,048 bytes	Maximum capacity of the RAW send buffer
RAW receive buffer	2,048 bytes	Maximum capacity of the RAW receive buffer
Hold timer	75 s (See note.)	The hold timer is used for active open processing of TCP sockets. An ETIMEDOUT error will occur if connection is not completed within 75 s.
Resend timer	Initial value: 250 ms Maximum value: 64 s	The resend timer is used to monitor completion of reception of arrival confirmations when transferring data via TCP sockets. If the timer setting is exceeded before arrival confirmation is received, data is resent. Resends are performed from the first timeout (1 s) through the 12th timeout (64 s). An ETIMEDOUT error will occur after the 12th timeout.
Continue timer	Initial value: 1 s Maximum value: 60 s	The continue timer starts if preparations have been completed to send data but the send window is too small (either 0 or too small) to send the data and the remote node has not requested that communications be restarted. Confirmation of the window size is requested from the remote node when the continue timer times out. The initial value of the timer is 5 s and confirmation processing will continue consecutively with increasingly longer times until the maximum time of 60 s is reached.
2MSL timer	60 s	The 2MSL timer starts at the TCP socket that first closes the socket and will run for 60 s in the TIME_WAIT status.
IP reassemble timer	12 s	A fragmented IP packet is discarded if it cannot be reassembled within 12 seconds.
ARP timer	20 min/3 min	If a complete ARP table entry (with an Ethernet address) is not referred to for 20 minutes, it is removed from the table. An incomplete ARP table entry (no response yet returned to the ARP request) is removed from the table after 3 minutes.
Window size (initial value of maximum window size)	4,096 bytes	The initial value of the maximum capacity used to control the convergence of TCP sockets. Actually, the node negotiates with the remote node and uses the smaller of the values for the two nodes. The window size will fluctuate with the available space in the TCP reception buffers of the remote node when processing communications.
Fragment size	1,500 bytes	Data packets are fragmented into 1,500-byte IP packets. UDP data is separated into 1,472-byte fragments before sending.
Segment size	1,024 bytes	TCP data is separated into 1,024-byte units, unless the segments are different, in which case it will be separated into 536-byte units.
TTL (Time to Live)	30	Decrement each time an IP router is passed.
Keep-alive timer	First time: 5 min Resend: 5 s × 5 times	The keep-alive timer is used for the keep-alive function with TCP connections. It must be used with UCMM, Class 3.

**Note** The hold time is 3 s for the UCMM service, Class 3 service, and tag data link open/close processing.





# Appendix C

## TCP Status Transitions

The TCP socket status can be confirmed using the socket status data returned for the FINS command SOCKET STATUS READ (27 64).

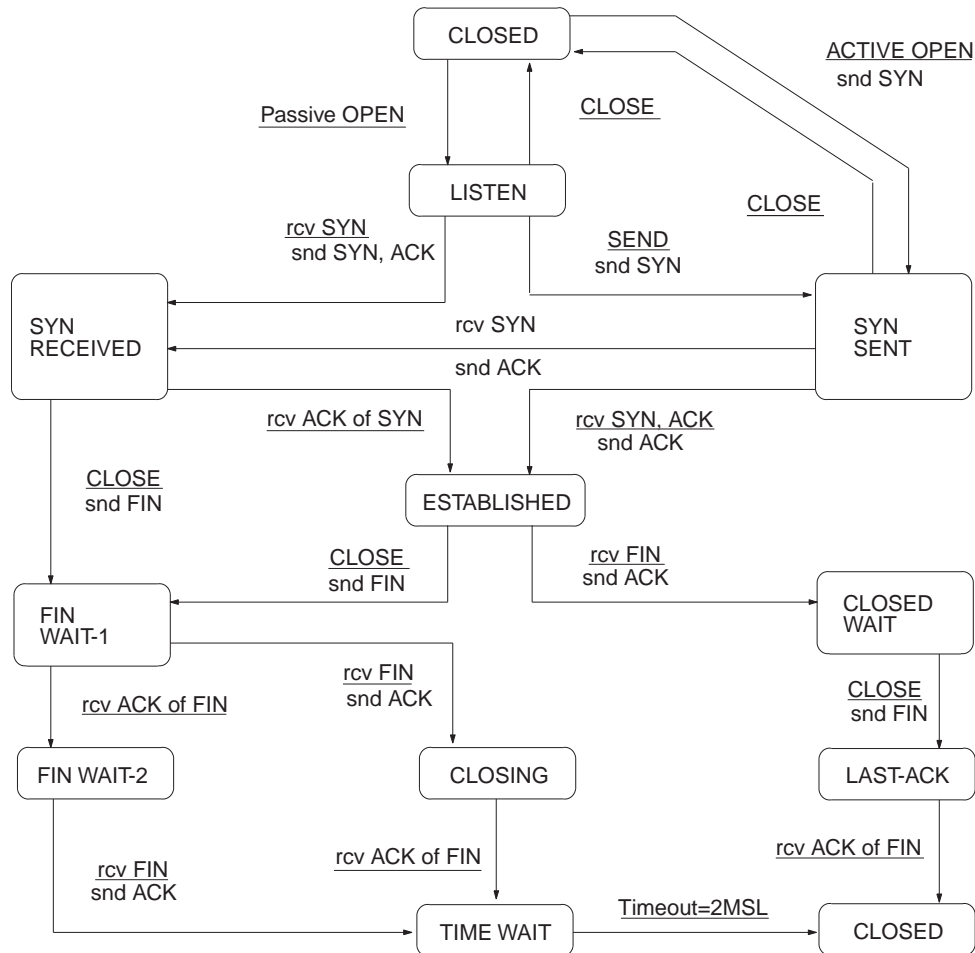

Status	Meaning
CLOSED	Connection closed.
LISTEN	Waiting for connection.
SYN SENT	SYN sent in active status.
SYN RECEIVED	SYN received and sent.
ESTABLISHED	Already established.
CLOSE WAIT	FIN received and waiting for completion.
FIN WAIT 1	Completed and FIN sent.
CLOSING	Completed and exchanged FIN. Awaiting ACK.
LAST ACK	FIN sent and completed. Awaiting ACK.
FIN WAIT 2	Completed and ACK received. Awaiting FIN.
TIME WAIT	After closing, pauses twice the maximum segment life (2MSL).



# Appendix D

## CIP Message Communications

This appendix describes CIP message communications.

The basic concepts of CIP message communications are described in this appendix from *CIP Object* on page 383 through *Example of CIP Message Creation* on page 388. Read these sections to improve your understanding of CIP message communications.

### CIP Object

#### Object Model

In the CIP (Common Industrial Protocol) system, each device is modeled as a group of “Objects.” An Object abstractly represents a related group of the device’s data values.

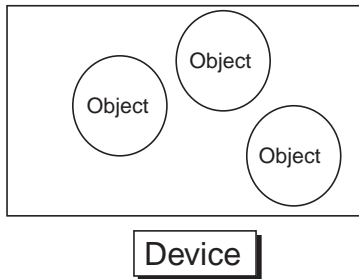

When accessing the device from the outside, access an Object.

An Object represents the abstracted device function, processing, and the resulting data.

A request from the outside of Object, such as Read Data, is called “Service.”

Data belonging to the Object is called “Attribute.”

The actual entity of Object is called “Instance” or “Object Instance.”

When Object is generalized, it is called “Class.” For example, “Japan” is one of Instances (Object Instances) of Class “Nation.”

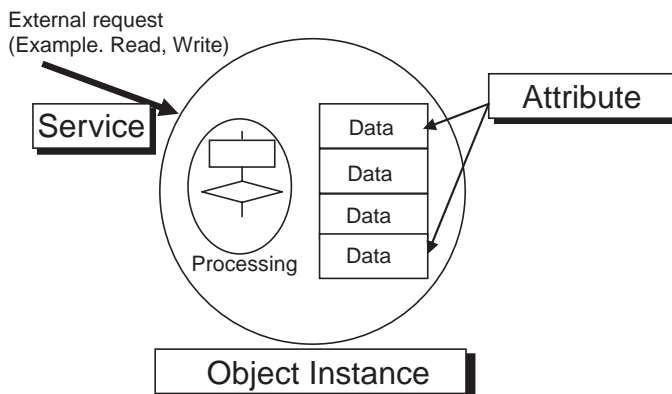

**Terminology**

In CIP specifications, “Object,” “Class,” “Instance,” “Attribute” and “Service” are defined as follows:

Term	Meaning
<b>Object</b>	An abstract representation of a particular component within a product.
<b>Class</b>	A set of objects that all represent the same kind of system component. A class is a generalization of an object. All objects in a class are identical in form and behavior, but may contain different attribute values.
<b>Instance</b>	A specific and real (physical) occurrence of an object. For example: New Zealand is an instance of the object class Country. The terms Object, Instance, and Object Instance all refer to a specific Instance.
<b>Attribute</b>	A description of an externally visible characteristic or feature of an object. Typically, attributes provide status information or govern the operation of an Object. For example: the ASCII name of an object; and the repetition rate of a cyclic object.
<b>Service</b>	A function supported by an object and/or object class. CIP defines a set of common services and provides for the definition of Object Class and/or Vendor Specific services.

**Specifying an Object Address (Request Path)**

This is the basic concept involved in accessing an Object or Attribute.

Each Object Class has a “Class ID”.

There are two types of “Class ID”; one is standardized by ODVA and the other is decided independently by each device vendor.

Each Object Instance also has ID. This is called “Instance ID.” Different Instance ID is assigned to each Object. As for Object Class standardized by ODVA, Instance ID is given to it according to the ODVA method. On the other hand, vendor’s own Instance ID is decided independently by the vendor.

Each Attribute also has “Attribute ID.”

Each Object is accessed to by using “Class ID,” “Instance ID,” and “Attribute ID.”

In the device, you can designate Object by specifying these three IDs.

When requesting “Service,” you should specify “Class ID,” “Instance ID,” and “Attribute ID.” (Instance ID and Attribute ID may not be required, depending on the Service.)

The “Class ID,” “Instance ID,” and “Attribute ID” identify a location in the device and are known as the request path.

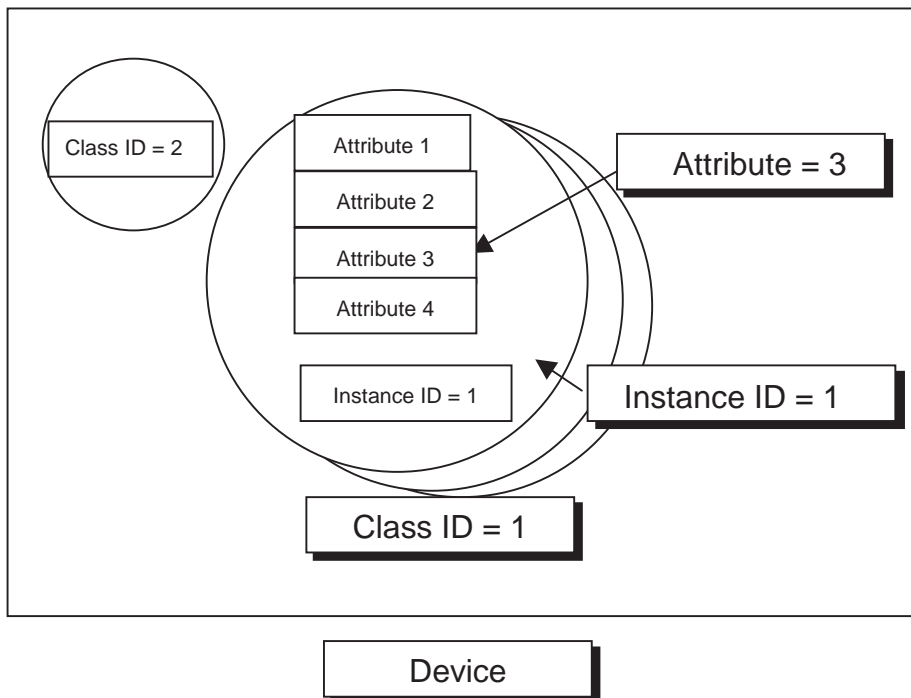

## Route Path

### Route Path

In the CIP, unlike the internet protocol, the transmission frame contains a complete relay route from the transmission node to the reception node. The described route is called the “route path.” The route path is described as “EPATH type.”

The basic concept of the route path is as follows:

First of all, specify a network port of the transmission node with the destination network, and specify a node address (called the Link Address) on that network. For the relay node, similarly, specify a network port with the destination network and node address on that network. Then, repeat the same procedure to the final destination.

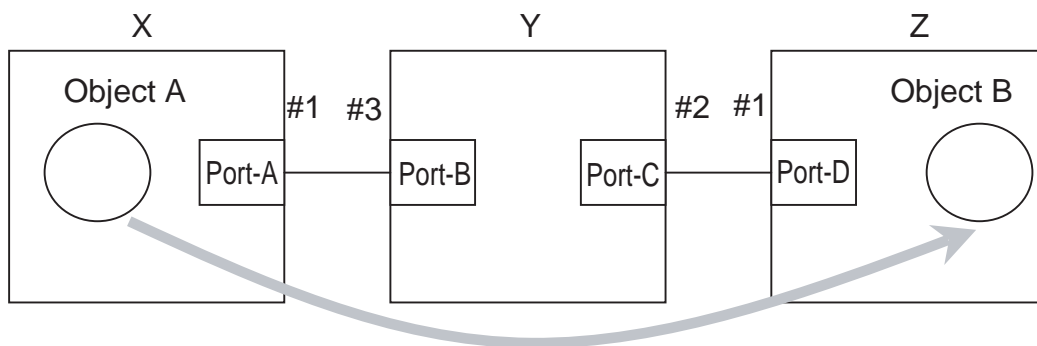

When sending data from X to Z.

**Route Path = Port A: #3, Port C: #1**

Send data from the network port of X (Port-A) to #3 on that circuit, and the data reaches Y. Then, send it from the network port of Y (Port-C) to #1 on that circuit. Through this procedure, the destination node Z can be designated.

### Description by EPATH Type

In CIP, the EPATH type is used to describe the route path and request path.

With this method, the route path and request path are divided into segments and a value is assigned to each segment, so the route path description shows the path to the final destination when the data segments are joined together.

The segment includes the segment type information and the segment data.

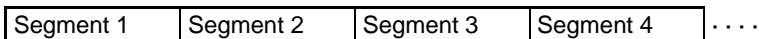

#### Details of Segment Type

The interpretation method of a segment is included in the first 1 byte, which consists of two parts; a 3-bit “Segment Type” and a 5-bit “Segment Format.”

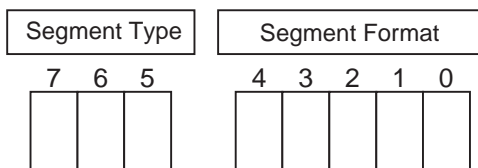

According to CIP Specifications, the Segment Type specifications are decided as follows:

Segment Type			Description
7	6	5	
0	0	0	Port Segment
0	0	1	Logical Segment
0	1	0	Network Segment
0	1	1	Symbolic Segment
1	0	0	Data Segment
1	0	1	Data Type
1	1	0	Data Type
1	1	1	Reserved

The specifications of Segment Format are different for each Segment Type.

The following sections describe Port Segment, Logical Segment, and Data Segment which are needed to use the CIP message communications instructions.

### Port Segment

The Port Segment is used to specify the path described above.

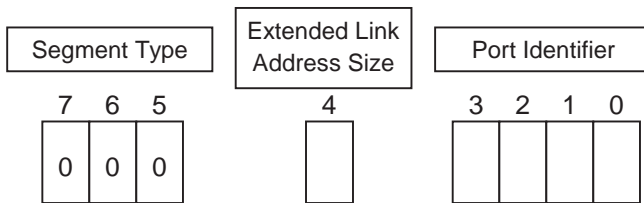

Set the ID of the port in Port Identifier.

The Port Identifier is 4 bits, so it can have a value between 0 and 15. A port identifier of “0” is reserved and not available. A port identifier of “1” indicates the backplane port.

A port identifier of “15” has a special meaning, which indicates that the size of Port Identifier is larger than 1 byte, and the 4-bit port identifier (15) is followed by 2-byte Port Identifier. The port identifier does not exceed 1 byte when using the EtherNet/IP Unit or built-in EtherNet/IP port, so this special case is not explained here.

Set the Extended Link Address Size to “1” when that port’s Link Address is larger than 1 byte.

The following diagram shows the Port Segment value when the Extended Link Address Size is set to “0.”

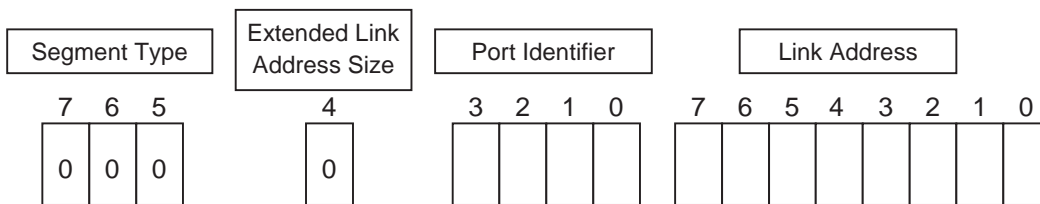

Specify the size of Link Address when the Extended Link Address Size is set to “1.” The following diagram shows the Port Segment value in this case.

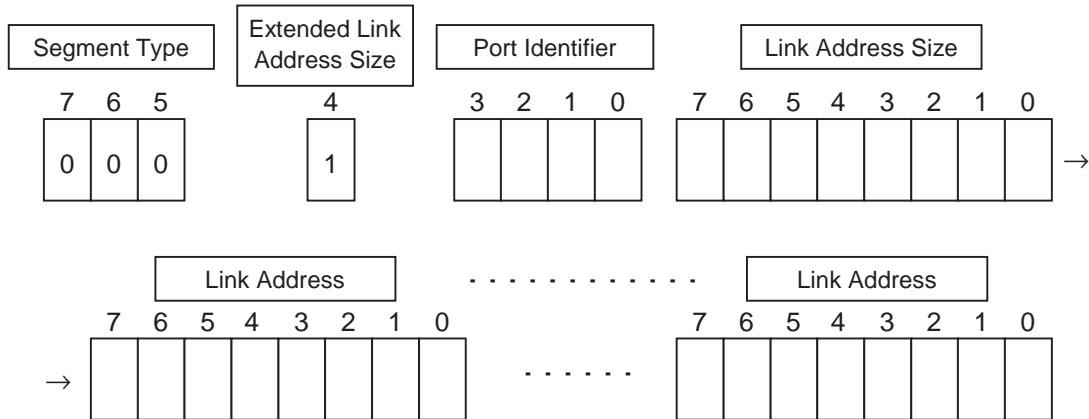

Always set the Link Address to an even number of bytes. If there is an odd number of bytes, pad the Link Address with “00” so that it has an even number of bytes.

**Logical Segment**

The Logical Segment is used to specify the request path.

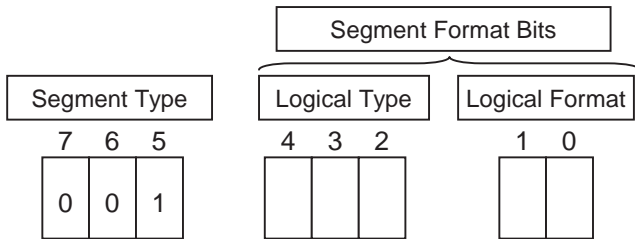

Logical Type			Description
4	3	2	
0	0	0	Class ID
0	0	1	Instance ID
0	1	0	Member ID
0	1	1	Connection Point
1	0	0	Attribute ID
1	0	1	Special (Do not use the logical addressing definition for the Logical Format.)
1	1	0	Service ID (Do not use the logical addressing definition for the Logical Format.)
1	1	1	Reserved

Logical Format		Description
1	0	
0	0	8-bit logical address
0	1	16-bit logical address
1	0	32-bit logical address
1	1	Reserved

The 32-bit logical address format is reserved and cannot be used.

The 8-bit and 16-bit logical address can be used for the Class ID and Instance ID, which specify the request path.

The 8-bit logical address can be used for the Attribute ID. Use the Attribute ID when requesting a Service of a particular Object of a particular device.

## Example of CIP Message Creation

### Setting the Route Path

#### Port Number

The following description explains the network port, which is used to specify the route path. In the CJ2 Series, the Backplane is also considered part of the network when specifying the Link Address.

#### **CPU Unit**

CJ2 (Not supported by CS1/CJ1 CPU Units.)

Each CPU Unit has one backplane port. By convention, the built-in port on a CJ2H-CPU6□-EIP or a CJ2M-CPU3□ CPU Unit functions as a CPU Bus Unit.

Port	Port Number
Backplane	1

The Backplane port is the Backplane. CPU Unit communications routed through CPU Bus Units always travel through the backplane.

#### **EtherNet/IP Unit or CJ2 Built-in EtherNet/IP Port**

The EtherNet/IP Unit has two ports. A CJ2 CPU Unit also has two built-in EtherNet/IP ports. One is a Backplane port and the other is an Ethernet port.

The Backplane port is the Backplane. Communications routed through the CPU Unit, a Special I/O Unit, or another CPU Bus Unit always travel through the backplane.

Port	Port Number
Backplane	1
Ethernet	2

#### Link Address

The Link Address is a node address on the network, which is used to specify the route path.

The method to set the Link Address is different for each network.

In the CS/CJ Series, the Backplane is also considered part of the network when specifying the Link Address.

#### **Backplane**

- **CPU Bus Unit or Special I/O Unit**

In the CS/CJ Series, the base unit is recognized as a backplane port.

CPU Bus Units, such as the EtherNet/IP Unit, are also recognized as nodes on the backplane port.

The Link Address of a CPU Bus Unit on the Backplane is the "unit number + 10 hex." For example, when the unit number is 0, the Link Address is 10 hex. When the unit number is F, the Link Address is 1F hex.

The Link Address of a Special I/O Unit on the Backplane is the "unit number + 20 hex." For example, when the unit number is 0, the Link Address is 20 hex.

#### **Network**

- **EtherNet/IP**

The Ethernet port's Link Address is described by the IP address.

The IP address must be described entirely in ASCII.

For example, IP address of 192.168.200.200 will be [31] [39] [32] [2E] [31] [36] [38] [2E] [32] [30] [30] [2E] [32] [30] [30].



## Response Codes

### General Status Code

The General Status Code is stored in the response data after execution of the CMND instruction has been completed.

General Status Code (hex)	Status Name	Description of Status
00	Success	Service was successfully performed by the object specified.
01	Connection failure	A connection related service failed along the connection path.
02	Resource unavailable	Resources needed for the object to perform the requested service were unavailable.
03	Invalid parameter value	See Status Code 20 hex, which is the preferred value to use for this condition.
04	Path segment error	The path segment identifier or the segment syntax was not understood by the processing node. Path processing shall stop when a path segment error is encountered.
05	Path destination unknown	The path is referencing an object class, instance or structure element that is not known or is not contained in the processing node. Path processing shall stop when a path destination unknown error is encountered.
06	Partial transfer	Only part of the expected data was transferred.
07	Connection lost	The messaging connection was lost.
08	Service not supported	The requested service was not implemented or was not defined for this Object Class/Instance.
09	Invalid attribute value	Invalid attribute data detected.
0A	Attribute list error	An attribute in the Get_Attribute_List or Set_Attribute_List response has a non-zero status.
0B	Already in requested mode/state	The object is already in the mode/state being requested by the service.
0C	Object state conflict	The object cannot perform the requested service in its current mode/state.
0D	Object already exists	The requested instance of object to be created already exists.
0E	Attribute not settable	A request to modify a non-modifiable attribute was received.
0F	Privilege violation	A permission/privilege check failed.
10	Device state conflict	The device's current mode/state prohibits the execution of the requested service.
11	Reply data too large	The data to be transmitted in the response buffer is larger than the allocated response buffer
12	Fragmentation of a primitive value	The service specified an operation that is going to fragment a primitive data value, i.e. half a REAL data type.
13	Not enough data	The service did not supply enough data to perform the specified operation.
14	Attribute not supported	The attribute specified in the request is not supported.
15	Too much data	The service supplied more data than was expected.
16	Object does not exist	The object specified does not exist in the device.
17	Service fragmentation sequence not in progress	The fragmentation sequence for this service is not currently active for this data.
18	No stored attribute data	The attribute data of this object was not saved prior to the requested service.
19	Store operation failure	The attribute data of this object was not saved due to a failure during the attempt.
1A	Routing failure (request packet too large)	The service request packet was too large for transmission on a network in the path to the destination. The routing device was forced to abort the service.
1B	Routing failure (response packet too large)	The service response packet was too large for transmission on a network in the path from the destination. The routing device was forced to abort the service.
1C	Missing attribute list entry data	The service did not supply an attribute in a list of attributes that was needed by the service to perform the requested behavior.

General Status Code (hex)	Status Name	Description of Status
1D	Invalid attribute value list	The service is returning the list of attributes supplied with status information for those attributes that were invalid.
1E	Embedded service error	An embedded service resulted in an error.
1F	Vendor specific error	A vendor specific error has been encountered. The Additional Code Field of the Error Response defines the particular error encountered. Use of this General Error Code should only be performed when none of the Error Codes presented in this table or within an Object Class definition accurately reflect the error.
20	Invalid parameter	A parameter associated with the request was invalid. This code is used when a parameter does not meet the requirements of this specification and/or the requirements defined in an Application Object Specification.
21	Write-once value or medium already written	An attempt was made to write to a write-once medium (e.g. WORM drive, PROM) that has already been written, or to modify a value that cannot be changed once established.
22	Invalid Reply Received	An invalid reply is received (e.g. reply service code does not match the request service code, or reply message is shorter than the minimum expected reply size). This status code can serve for other causes of invalid replies.
23-24		Reserved by CIP for future extensions
25	Key Failure in path	The Key Segment that was included as the first segment in the path does not match the destination module. The object specific status shall indicate which part of the key check failed.
26	Path Size Invalid	The size of the path which was sent with the Service Request is either not large enough to allow the Request to be routed to an object or too much routing data was included.
27	Unexpected attribute in list	An attempt was made to set an attribute that is not able to be set at this time.
28	Invalid Member ID	The Member ID specified in the request does not exist in the specified Class/Instance/Attribute.
29	Member not settable	A request to modify a non-modifiable member was received.
2A	Group 2 only server general failure	This error code may only be reported by DeviceNet group 2 only servers with 4K or less code space and only in place of Service not supported, Attribute not supported and Attribute not settable.
2B-CF	---	Reserved by CIP for future extensions
D0-FF	Reserved for Object Class and service errors	This range of error codes is to be used to indicate Object Class specific errors. Use of this range should only be performed when none of the Error Codes presented in this table accurately reflect the error that was encountered.

**Example of Additional Status in case that General Status Is 01 Hex.  
(Status of Connection Manager Object)**

General Status (hex)	Additional Status (hex)	Explanation
01	0100	Connection in Use or Duplicate Forward Open.
01	0103	Transport Class and Trigger combination not supported
01	0106	Ownership Conflict
01	0107	Connection not found at target application.
01	0108	Invalid Connection Type. Indicates a problem with either the Connection Type or Priority of the Connection.
01	0109	Invalid Connection Size
01	0110	Device not configured
01	0111	RPI not supported. May also indicate problem with connection time-out multiplier, or production inhibit time.
01	0113	Connection Manager cannot support any more connections
01	0114	Either the Vendor Id or the Product Code in the key segment did not match the device
01	0115	Product Type in the key segment did not match the device
01	0116	Major or Minor Revision information in the key segment did not match the device
01	0117	Invalid Connection Point
01	0118	Invalid Configuration Format
01	0119	Connection request fails since there is no controlling connection currently open.
01	011A	Target Application cannot support any more connections
01	011B	RPI is smaller than the Production Inhibit Time.
01	0203	Connection cannot be closed since the connection has timed out
01	0204	Unconnected Send timed out waiting for a response.
01	0205	Parameter Error in Unconnected Send Service
01	0206	Message too large for Unconnected message service
01	0207	Unconnected acknowledge without reply
01	0301	No buffer memory available
01	0302	Network Bandwidth not available for data
01	0303	No Tag filters available
01	0304	Not Configured to send real-time data
01	0311	Port specified in Port Segment Not Available
01	0312	Link Address specified in Port Segment Not Available
01	0315	Invalid Segment Type or Segment Value in Path
01	0316	Path and Connection not equal in close
01	0317	Either Segment not present or Encoded Value in Network Segment is invalid.
01	0318	Link Address to Self Invalid
01	0319	Resources on Secondary Unavailable
01	031A	Connection already established
01	031B	Direct connection already established
01	031C	Miscellaneous
01	031D	Redundant connection mismatch
01	031F	No connection resources exist for target path
01	0320-07FF	Vendor specific

## Priority/Time Ticks and Time Out Ticks

### Format of the Priority/Time Tick

Time tick	Base value (ms)	Maximum time-out time (ms) that can be set in the time out ticks
0000 hex	1	255
0001 hex	2	510
0010 hex	4	1,020
0011 hex	8	2,040
0100 hex	16	4,080
0101 hex	32	8,160
0110 hex	64	16,320
0111 hex	128	32,640
1000 hex	256	65,280
1001 hex	512	130,560
1010 hex	1,024	261,120
1011 hex	2,048	522,240
1100 hex	4,096	1,044,480
1101 hex	8,192	2,088,960
1110 hex	16,389	4,177,920
1111 hex	32,768	8,355,840

# Appendix E

## FINS Commands Addressed to EtherNet/IP Units or Built-in EtherNet/IP Ports

Command code		Function name	Remarks
MRC	SRC		
04	03	RESET	---
05	01	CONTROLLER DATA READ	---
06	01	CONTROLLER STATUS READ	---
08	01	INTERNODE ECHO TEST	---
	02	BROADCAST TEST RESULTS READ	---
	03	BROADCAST DATA SEND	---
21	02	ERROR LOG READ	---
	03	ERROR LOG CLEAR	---
27	20	PING	---
	30	FINS/TCP CONNECTION REMOTE NODE CHANGE REQUEST	---
	31	FINS/TCP CONNECTION STATUS READ	---
	50	IP ADDRESS TABLE WRITE	---
	57	IP ADDRESS WRITE	---
	60	IP ADDRESS TABLE READ	---
	61	IP ROUTER TABLE READ	---
	62	PROTOCOL STATUS READ	---
	63	MEMORY STATUS READ	---
	64	SOCKET STATUS READ	---
	65	ADDRESS INFORMATION READ	---
28	01	EXPLICIT MESSAGE SEND	---
	10	CIP UCMM MESSAGE SEND	---

### RESET

Resets the EtherNet/IP Unit or built-in EtherNet/IP port.

### Command Block

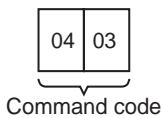

### Response Block

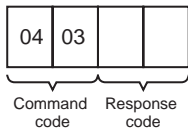

## Precautions

- No response will be returned if the command ends normally. A response will be returned only if an error occurs.
- In some cases, send requests (SEND(192)/RECV(193) instructions) made from the PLC to the EtherNet/IP Unit or built-in EtherNet/IP port just before execution of the RESET command may not be executed.
- Applications that use TCP/IP, such as FINS/TCP communications services, are closed immediately before resetting.

## Response Codes

Response code	Description
1001	Command too large

## CONTROLLER DATA READ

Reads the following data from the EtherNet/IP Unit or built-in EtherNet/IP port: Model number, version, IP address, subnet mask, FINS UDP port number, mode settings, Ethernet address.

### Command Block

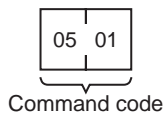

### Response Block

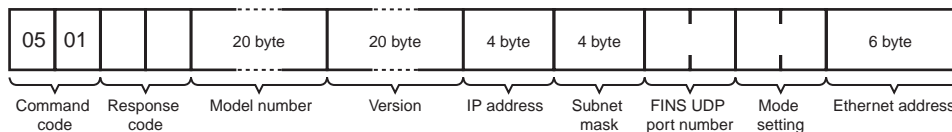

## Parameters

### Model number, Version (Response)

The model number and version of the EtherNet/IP Unit or built-in EtherNet/IP port are returned as ASCII characters occupying 20 bytes each (i.e., 20 characters each). If all bytes are not used, the remaining bytes will be all spaces (ASCII 20 Hex).

Example Model: CS1W-EIP21, CJ1W-EIP21, CJ2B-EIP21, or CJ2M-EIP21

Example Version: V2.00

By convention, the model number of the built-in EtherNet/IP port on a CJ2H-CPU□□-EIP CPU Unit is CJ2B-EIP21.

By convention, the model number of the built-in EtherNet/IP port on a CJ2M-CPU3□ CPU Unit is CJ2M-EIP21.

### IP Address, Subnet Mask (Response)

The IP address and subnet mask of the EtherNet/IP Unit or built-in EtherNet/IP port are returned as 4 bytes each.

### FINS UDP Port Number (Response)

The UDP port number of the EtherNet/IP Unit or built-in EtherNet/IP port for FINS is returned as 2 bytes.

### Mode Setting (Response)

The mode setting in the system setup is returned.

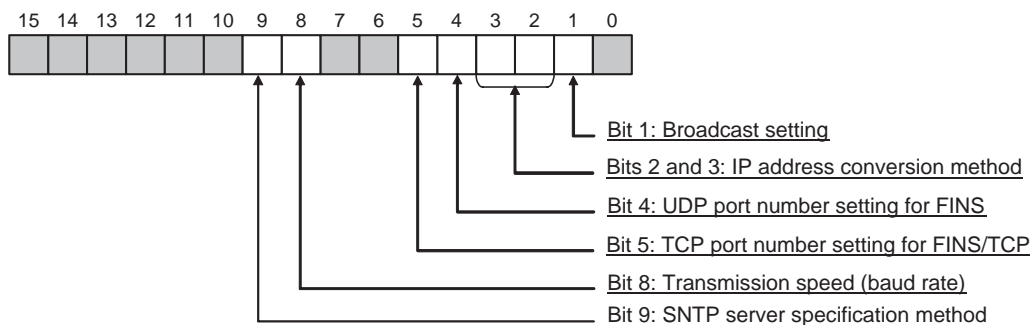

#### Broadcast Address Setting

Bit 1	Meaning
0	Broadcast with host number set to all ones (4.3BSD specifications)
1	Broadcast with host number set to all zeroes (4.2BSD specifications)

#### Communications Partner IP Address Conversion Method Setting

Bit 3	Bit 2	Meaning
0	0	Automatic generation method (dynamic)
0	1	Automatic generation method (static)
1	0	IP address table reference method
1	1	Combined method (IP address table reference + automatic generation (dynamic))

#### FINS/UDP Port Number Setting

Bit 4	Meaning
0	Default (9600)
1	Unit Setup value

#### FINS/TCP Port Number Setting

Bit 5	Meaning
0	Default (9600)
1	Unit Setup value

#### Baud Rate Setting

Bit 8	Meaning
0	Automatic detection
1	Fixed

#### SNTP Server Specification Method

Bit 9	Meaning
0	IP address
1	Host name

### Ethernet Address (Response)

The Ethernet address of the EtherNet/IP Unit or built-in EtherNet/IP port is returned.

**Note** This Ethernet address is listed on the label on the side of the EtherNet/IP Unit or (for a built-in EtherNet/IP port), on the CPU Unit.

## Response Codes

Response code	Description
0000	Normal end
1001	Command too large

## CONTROLLER STATUS READ

Reads the controller status.

### Command Block

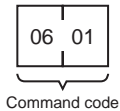

### Response Block

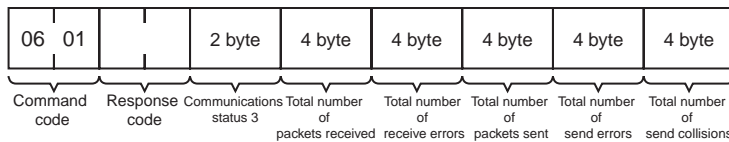

## Parameters

### Communications Status 3 (Response)

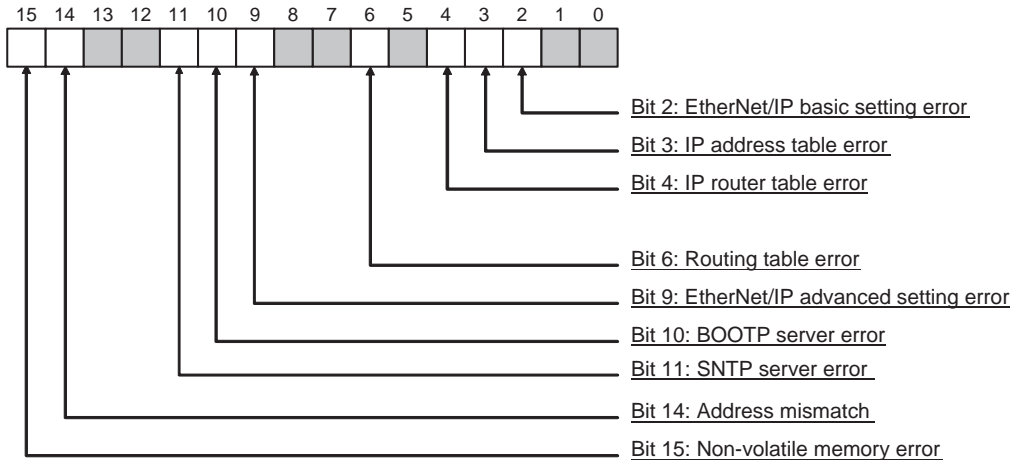

#### Ethernet Basic Setting Error

Bit 2	Meaning
0	No error
1	An error (such as an invalid IP address) was detected during the validity check of parameters related to the TCP/IP Interface Object and Ether Link Object.

#### IP Address Table Error

Bit 3	Meaning
0	No error
1	Error detected (More than 32 records, invalid IP address, or invalid FINS node address).



**IP Router Table Error**

Bit 3	Meaning
0	No error
1	Error detected (More than 8 records, or invalid IP address).

**Routing Table Error**

Bit 6	Meaning
0	No error
1	Error detected in routing table check.

**Ethernet Advanced Setting Error**

Bit 9	Meaning
0	No error
1	An error was detected during the validity check of vendor-specific parameters for the TCP/IP Interface Object and Ether Link Object.

**BOOTP Server Error**

Bit 10	Meaning
0	No error
1	Error detected. (A time-out occurred during communications with the BOOTP server).

**SNTP Server Error**

Bit 10	Meaning
0	No error
1	Error detected. (The setting of the host specification (IP address or host name) of the SNTP server is not correct, or communications with the SNTP server timed out.)

**Address Mismatch**

Bit 14	Meaning
0	No error
1	Error detected. (The address conversion method was set for automatic generation, but the host ID of the local IP address does not match the local node address (FINS node address).

**Non-volatile Memory Error**

Bit 15	Meaning
0	No error
1	Error detected. (The non-volatile memory's service life has expired, or the memory has failed).

**Total Number of Packets Received (Response)**

The total number of packets received by the EtherNet/IP Unit or built-in EtherNet/IP port is returned.

**Total Number of Receive Errors (Response)**

The total number of packet errors detected while the EtherNet/IP Unit or built-in EtherNet/IP port was receiving is returned.

The following types of error are detected:

- Short packet errors
- Alignment errors
- CRC errors
- Frame length errors (received frame: 1,515 bytes or more)
- Communications controller overflow errors

**Total Number of Packets Sent (Response)**

The total number of packets sent by the EtherNet/IP Unit or built-in EtherNet/IP port is returned.

**Total Number of Errors Sent (Response)**

The total number of packet errors detected while the EtherNet/IP Unit or built-in EtherNet/IP port was sending is returned.

**Total Number of Send Collisions (Response)**

Returns the number of packets damaged by 16 collisions with data from other nodes during EtherNet/IP Unit or built-in EtherNet/IP port transmissions.

**Precautions**

Counting of the total number of packets received, total number of receive errors, total number of packets sent, total number of errors sent, and total number of send collisions is discontinued when the counted value reaches the maximum value.

**Response Codes**

Response code	Description
0000	Normal end
1001	Command too large

**INTERNODE ECHO TEST**

Performs an echoback test (internode communications test) between specified nodes.

**Command Block**

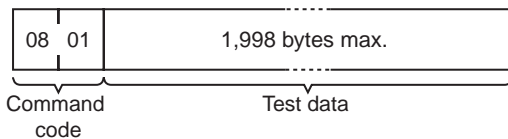

**Response Block**

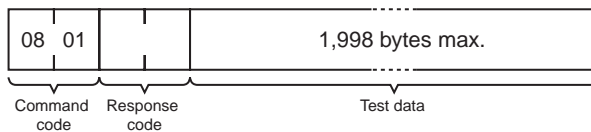

**Parameters**

**Test Data (Command, Response)**

This command specifies the data to be sent to the specified nodes. Up to 1,998 bytes can be specified. The response sends back data identical to the data specified in the command. An abnormality is assumed if the data returned in the response differs from the test data sent.

**Precautions**

- The test destination node is the destination node specified in the CMND(194) instruction operands.
- Always specify the unit address of the EtherNet/IP Unit or built-in EtherNet/IP port in the CMND(194) instruction.

## Response Codes

Response code	Description
0000	Normal end
1001	Command too large
1002	Command too small (No test data)

## BROADCAST TEST RESULTS READ

Reads the results (number of times data received) of the broadcast test.

### Command Block



### Response Block

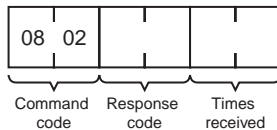

## Parameters

### Times Received (Response)

The number of times the data has been received normally during the broadcast send test is returned as a hexadecimal number. The number of times received is cleared each time the result is read.

## Response Codes

Response code	Description
0000	Normal end
1001	Command too large

## BROADCAST DATA SEND

Sends test data simultaneously to all nodes on the network.

### Command Block

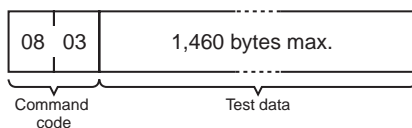

## Parameters

### Test Data (Command)

This command specifies the data to be sent to the specified nodes. Up to 1,460 bytes can be specified.

## Precautions

- No response is made to this command.
- When using this command, set the FINS header parameters (or the control data for the CMND(194) instruction) as follows:
  - Destination node address: FF (broadcast data)
  - Destination unit address: FE (EtherNet/IP Unit or built-in EtherNet/IP port)
  - Response/no response flag: 1 (no response)

## ERROR LOG READ

Reads the error log.

### Command Block

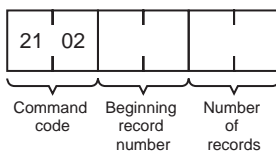

### Response Block

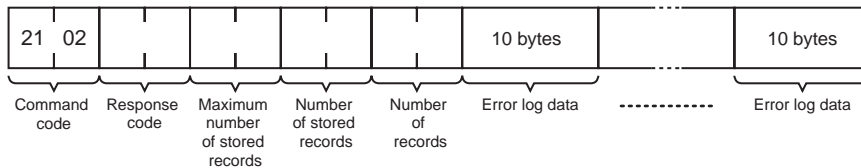

## Parameters

### Beginning Record Number (Command)

The first record to be read. The first record number can be specified in the range between 0000 and 003F (0 to 63 decimal) where 0000 is the oldest record.

### Number of Records (Command, Response)

The number of records to read is specified between 0001 and 0040 (1 to 64 decimal) in the command. The response returns the actual number of records read.

### Maximum Number of Stored Records (Response)

Indicates the maximum number of records that can be stored in the error log. The maximum number of error log records depends on the model of CPU Unit or CPU Bus Unit being used. In an EtherNet/IP Unit or built-in EtherNet/IP port, the maximum number of stored records is fixed at 40 (64 decimal).

### Number of Stored Records (Response)

The number of records stored at the time the command is executed is returned.

### Error Log Data (Response)

The specified number of error log records from the beginning record number is returned sequentially. The total number of bytes in the error log is calculated as the number of records x 10 bytes/record. Each error log record thus comprises 10 bytes, configured as follows:

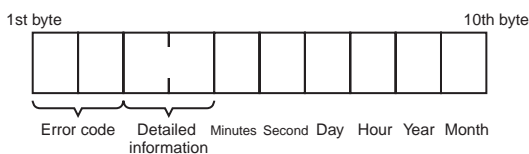

**Error Code, Detailed Information**

Details of the error stored in the record. Refer to 14-4-4 Error Log Error Codes for details.

**Minute, Second, Day, Hour, Year, Month**

Indicate the time at which the error stored in the record occurred.

**Precautions**

- If the error log contains fewer records than the number specified in the number of records parameter, all records stored in the error log at the time the command is executed will be returned and the command executed will end normally.

**Response Codes**

Response code	Description
0000	Normal end
1001	Command too large
1002	Command too small
1103	Beginning record number is out of range
110C	The number of read records is 0.

**ERROR LOG CLEAR**

Clears the error log for the EtherNet/IP Unit or built-in EtherNet/IP ports, and resets the *number of stored records* to 0.

**Command Block**

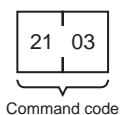

**Response Block**

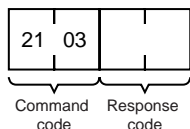

**Response Codes**

Response code	Description
0000	Normal end
1001	Command too large

**PING**

Performs processing equivalent to a UNIX computer's PING command (see below).

## Command Block

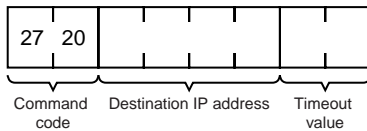

## Response Block

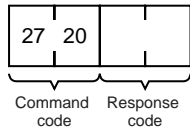

## Parameters

### Destination IP Address (Command)

The IP address (in hexadecimal) of the destination node for the PING command echo request packet.

### Timeout Value (Command)

The wait time for the echo reply packet. The value is set in seconds. The timeout time is set at 20 seconds if the value is specified as 0. If the echo reply packet is not received within the set time limit, the code for a timeout error will be set as the results storage response code.

## Remarks

### PING Command

The PING command runs the echoback test using the ICMP protocol. When the PING command is executed, an echo request packet is sent to the remote node ICMP. Correct communications are confirmed when the returned response packet is received normally. The echo reply packet is automatically returned by the remote node ICMP.

## Response Codes

Response code	Description
0000	Normal end (echo reply received from the remote node)
0205	Timeout error
1001	Command too large
1002	Command too small
1100	Zero destination address
220F	PING command currently being executed
2211	High traffic at Unit; cannot execute service.

## FINS/TCP CONNECTION REMOTE NODE CHANGE REQUEST

Requests a remote node change for the FINS/TCP connection.

The default destination IP address in a connection in which the EtherNet/IP Unit or built-in EtherNet/IP port is used as a client is the destination IP address set under the FINS/TCP Tab Page in the Unit Setup. By sending this command to the EtherNet/IP Unit or built-in EtherNet/IP port, the destination IP address for the specified connection can be changed to another IP address.

Remote node changes can be made only for connection numbers specified as FINS/TCP clients in the Unit Setup.

### Command Block

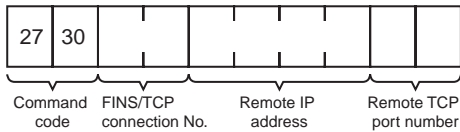

### Response Block

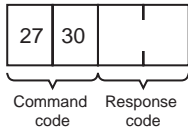

### Parameters

#### FINS/TCP Connection No. (Command)

Specifies, in two bytes, the FINS/TCP connection number (1 to 16) for which the change is to be made.

#### Remote IP Address (Command)

Specifies the remote node's IP address (must be non-zero) in hexadecimal.

#### Remote Port Number (Command)

Specifies the remote TCP port number (must be non-zero) with this command.

### Response Codes

Response code	Description
0000	Normal end
0105	Node address setting error Local IP address setting error
0302	CPU Unit error; execution not possible.
1001	Command too large
1002	Command too small
1100	Connection number not set from 1 to 16 Remote IP address set to 0 Remote TCP port number set to 0
2230	Connection already established with specified remote node
2231	Specified connection number not set as FINS/TCP client in Unit Setup
2232	Remote node change processing for specified connection number aborted because change request received during processing

## FINS/TCP CONNECTION STATUS READ

Reads the FINS/TCP connection status.

### Command Block

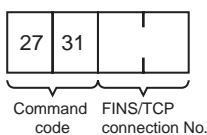

## Response Block

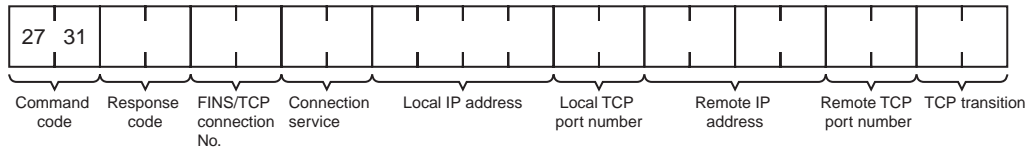

## Parameters

### **FINS/TCP Connection No. (Command, Response)**

Command: Specifies, in two bytes, the FINS/TCP connection number (1 to 16) for which the status is to be read.

Response: Specifies the FINS/TCP connection number (1 to 16) for which the status was read.

### **Connection Service (Response)**

Specifies the service that is being used for the FINS/TCP connection as a number.

0003: FINS/TCP server

0004: FINS/TCP client

### **Local IP Address (Response)**

Specifies the IP address for the local node in hexadecimal.

### **Local TCP Port Number (Response)**

Specifies the TCP port number for the local node.

### **Remote IP Address (Response)**

Specifies the IP address for the remote node in hexadecimal.

### **Remote TCP Port Number (Response)**

Specifies the TCP port number for the remote node.

### **TCP Transitions (Response)**

Specifies the TCP connection status using the following numbers.

For details on TCP status changes, refer to *Appendix C TCP Status Transitions*.

Number	Status	Meaning
00000000	CLOSED	Connection closed.
00000001	LISTEN	Waiting for connection.
00000002	SYN SENT	SYN sent in active status.
00000003	SYN RECEIVED	SYN received and sent.
00000004	ESTABLISHED	Already established.
00000005	CLOSE WAIT	FIN received and waiting for completion.
00000006	FIN WAIT 1	Completed and FIN sent.
00000007	CLOSING	Completed and exchanged FIN. Awaiting ACK.
00000008	LAST ACK	FIN sent and completed. Awaiting ACK.
00000009	FIN WAIT 2	Completed and ACK received. Awaiting FIN.
0000000A	TIME WAIT	After closing, pauses twice the maximum segment life (2MSL).



## Response Codes

Response code	Description
0000	Normal end
0105	Node address setting error Local IP address setting error
0302	CPU Unit error; execution not possible.
1001	Command too large
1002	Command too small
1100	Connection number not set from 1 to 16

## IP ADDRESS TABLE WRITE

Writes the IP address table.

### Command Block

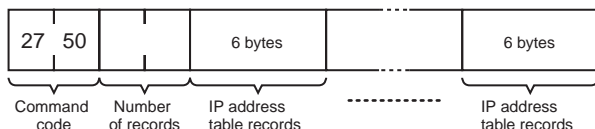

### Response Block

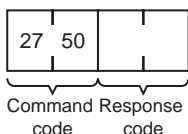

## Parameters

### Number of Records (Command)

The number of records to write is specified in hexadecimal between 0000 and 0020 (0 to 32 decimal) in the command. If this value is set to 0, the IP address table will be cleared so that no records are registered.

### IP Address Table Records (Command)

Specify the IP address table records. The number of records specified must be provided. The total number of bytes in the IP address table records is calculated as the number of records × 6 bytes/record. The configuration of the 6 bytes of data in each record is as shown in the following diagram.

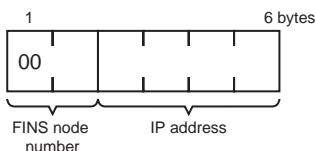

#### FINS Node Address

Node address for communications via the FINS command (hexadecimal).

#### IP Address

IP address used by TCP/IP protocol (hexadecimal).

## Precautions

- The registered IP address table will not be effective until the PLC or EtherNet/IP Unit or built-in EtherNet/IP port is restarted.

- An error response will be returned if the IP address conversion method in the system mode settings is set for automatic generation on the FINS/UDP Tab Page of the Unit.

## Response Codes

Response code	Description
0000	Normal end (echo reply received from the remote node)
1001	Command too large
1002	Command too small
1003	The number of records specified does not match the sent data length.
110C	The number of records is not between 0 and 32. The FINS node address is not between 1 and 126 The IP address is 0.
2307	IP address conversion method is set for automatic generation.

## IP ADDRESS WRITE

Write the local IP address and the subnet mask in the CPU Bus Unit System Setup.

### Command Block

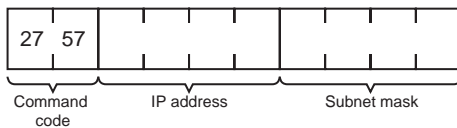

### Response Block

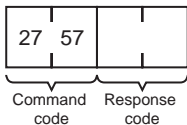

## Parameters

### IP Address (Command)

Specify the local IP address of the EtherNet/IP Unit or built-in EtherNet/IP port using 4 pairs of 2-digit hexadecimal numbers in the range 00.00.00.00 to FF.FF.FF.FF (0.0.0.0 to 255.255.255.255 decimal). Specify 0.0.0.0 to enable the local IP address set in the allocated DM Area words.

Example: 150.31.2.83

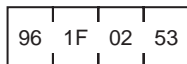

### Subnet Mask (Command)

Specify the local IP address of the EtherNet/IP Unit or built-in EtherNet/IP port using 4 pairs of hexadecimal numbers in the range 00.00.00.00 to FF.FF.FF.FF (0.0.0.0 to 255.255.255.255 decimal).

Example: 255.255.255.255



## Response Codes

Response code	Description
0000	Normal end
1001	Command too large
1002	Command too small

## Precautions

- The local IP address and subnet mask set by this command are written to the CPU Bus Unit System Setup for the EtherNet/IP Unit or built-in EtherNet/IP port.
- The new local IP address and subnet mask settings will become effective when the PLC or EtherNet/IP Unit or built-in EtherNet/IP port is restarted.

## IP ADDRESS TABLE READ

Reads the IP address table.

### Command Block

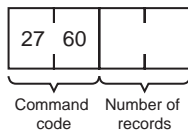

### Response Block

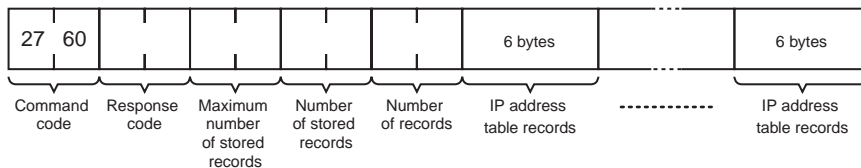

## Parameters

### Number of Records (Command, Response)

The number of records to read is specified between 0000 and 0020 (0 to 32 decimal) in the command. If this value is set to 0, the number of stored records is returned but the IP address table records are not returned. The response returns the actual number of records read.

### Maximum Number of Stored Records (Response)

The maximum number of records that can be stored in the IP address table is returned. The maximum number of stored records is fixed at 0020 (32 records).

### Number of Stored Records (Response)

The number of IP address table records stored at the time the command is executed is returned as a hexadecimal number.

### IP Address Table Records (Response)

The number of IP address table records specified in the number of records parameter is returned. The total number of bytes in the IP address table records is calculated as the number of records × 6 bytes/record. The configuration of the 6 bytes of data in each record is as shown in the following diagram.

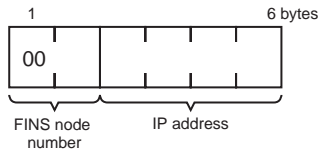

**FINS Node Address**

Node address for communications via the FINS command (in hexadecimal).

**IP Address**

IP number used by TCP/IP protocol (in hexadecimal).

**Precautions**

- If the IP address table contains fewer records than the number specified in the *number of records* parameter, all the records contained in the IP address table when the command is executed will be returned and the command execution will end normally.
- An error response will be returned if the IP address conversion method in the system mode settings is set to the automatic generation method on the FINS/UDP Tab Page of the Unit.

**Response Codes**

Response code	Description
0000	Normal end
1001	Command too large
1002	Command too small
2307	IP address conversion method is set to the automatic generation method.

**IP ROUTER TABLE READ**

Reads the IP router table.

**Command Block**

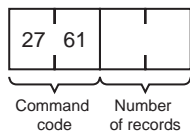

**Response Block**

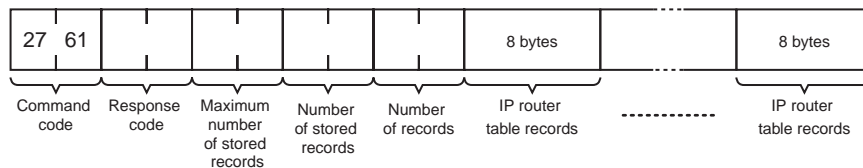

**Parameters**

**Number of Records (Command, Response)**

The number of records to read is specified between 0000 and 0008 (0 to 8 decimal) in the command. If this value is set to 0, the number of stored records will be returned but the IP router table records will not be returned. The response returns the actual number of records read.

**Maximum Number of Stored Records (Response)**

The maximum number of records that can be stored in the IP router table is returned. The maximum number of stored records is fixed at 0008 (8 records).

**Number of Stored Records (Response)**

The number of IP router table records stored at the time the command is executed is returned in hexadecimal.

**IP Router table Records (Response)**

The number of IP router table records specified in the *number of records* parameter is returned. The total number of bytes in the IP router table records is calculated as the number of records × 8 bytes/record. The configuration of the 8 bytes of data in each record is shown below.

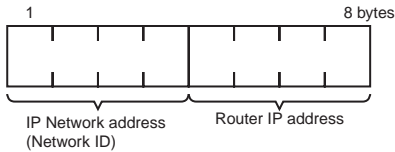

**IP Network Address**

The network ID from the IP address in hexadecimal. The network ID part corresponding to the address class (determined by the leftmost 3 bits) set here, is enabled.

**Router IP Address**

The IP address (in hexadecimal) of a router connected to a network specified with IP addresses.

**Precautions**

If the IP router table contains fewer records than the number specified in the *number of records* parameter, all the records contained in the IP router table when the command is executed will be returned and the command execution will end normally.

**Response Codes**

Response code	Description
0000	Normal end
1001	Command too large
1002	Command too small

**PROTOCOL STATUS READ**

Reads the protocol status or the EtherNet/IP Unit or built-in EtherNet/IP port.

**Command Block**

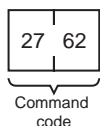

**Response Block**

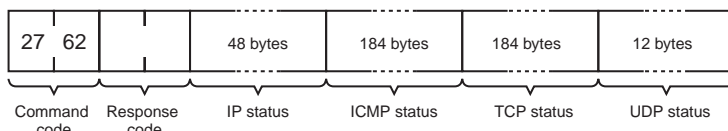

## Parameters

### **IP Status (Response)**

Twelve types of IP status information occupying 4 bytes each are returned in the following sequence. Each value is returned as an 8-digit hexadecimal value.

1. Total number of IP packets received.
2. The number of IP packets discarded due to an error with the checksum in the packet header.
3. The number of IP packets discarded because the received packet was larger than the overall packet length value in the packet header.
4. The number of IP packets discarded because the minimum size of the IP header data could not be stored in the first short buffer (See note.) when an attempt was made to store the packet.
5. The number of packets discarded for one of the following reasons:
  - The IP header length value in the IP header was smaller than the smallest size of the IP header.
  - The size of the first short buffer (See note.) was smaller than the IP header length value in the IP header when storing the packet.
6. The number of IP packets discarded because the IP header length was larger than the overall packet length value in the packet header.
7. The number of fragmented packets received.
8. The number of received fragmented IP packets discarded because a queue for reassembly could not be secured.
9. The number of fragmented IP packets discarded because they could not be reassembled within 12 seconds after being received.
10. Always 0.
11. The number of packets addressed to other networks that have been discarded.
12. Always 0.

**Note** Refer to *MEMORY STATUS READ* on page 413 for details on the short buffer.

### **ICMP Status (Response)**

Ten types (46 items) of ICMP status information occupying 4 bytes each are returned in the following sequence. Each value is returned as an 8-digit hexadecimal value.

1. The number of times the ICMP error routine was called. The ICMP error routine uses ICMP packets to inform the source about errors. The routine is called when an illegal packet is received (error in IP option processing or error in relay processing) or if the object port does not exist when using UDP.
2. Always 0.
3. Always 0.
4. Total number of outputs of each packet type during ICMP output. The 19 statistical values are returned in the order shown below. Contents are defined for 13 types only; all other types contain 0. Only #0, #3, #14, #16, and #18 are counted by the EtherNet/IP Unit or built-in EtherNet/IP port.

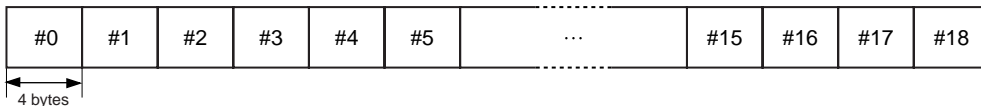

Type number	Description
#0	Echo reply
#1, #2	Undefined, always 0
#3	Destination unreachable
#4	Source quench
#5	Routing redirect

Type number	Description
#6, #7	Undefined, always 0
#8	Echo
#9, #10	Undefined, always 0
#11	Time exceeded
#12	Parameter problem
#13	Time stamp
#14	Time stamp reply
#15	Information request
#16	Information request reply
#17	Address mask request
#18	Address mask reply

5. The number of received ICMP packets discarded because the type-indication code was out of range.
6. The number of received ICMP packets discarded because the overall packet length value in the packet header was smaller than the minimum ICMP packet length.
7. The number of received ICMP packets discarded because of an incorrect checksum value in the packet header.
8. The number of received ICMP packets discarded because the ICMP header length value in the packet header did not match the lengths of individual header types.
9. The number of responses returned to received ICMP packets requiring a response.
10. Total number of inputs of each packet type during ICMP input. The 19 statistical values are returned in the order shown below. Contents are defined for 13 types only; all other types contain 0.

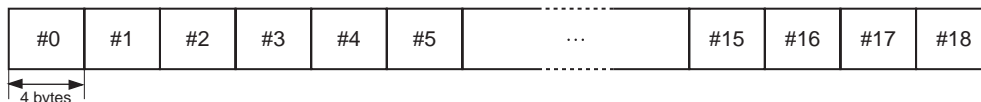

Type number	Description
#0	Echo reply
#1, #2	Undefined, always 0
#3	Destination unreachable
#4	Source quench
#5	Routing redirect
#6, #7	Undefined, always 0
#8	Echo
#9, #10	Undefined, always 0
#11	Time exceeded
#12	Parameter problem
#13	Time stamp
#14	Time stamp reply
#15	Information request
#16	Information request reply
#17	Address mask request
#18	Address mask reply

**TCP Status (Response)**

Three types (46 items) of TCP status information occupying 4 bytes each are returned in the following sequence. Each value is returned as an 8-digit hexadecimal value.

**1) Connection Information (60 Bytes)**

Fifteen items are returned in the following sequence:

1. The number of times active connections were correctly established.
2. The number of times a SYN packet was received while waiting to establish a passive connection.
3. The number of times active or passive connections were correctly established.
4. The number of times an established connection was cut off.
5. The number of times the connection wait status was cut off.
6. The number of times protocol control blocks or other actively allocated structures were released.
7. The number of segments for the round-trip time (time from segment transmission to ACK).
8. The number of times the round-trip time was changed.
9. The number of times a delayed acknowledgement (ACK) was sent. If the order of the received segments is reversed, ACK is sent with a packet of data separate from ACK (response to input data, etc.) or is immediately sent with the ACK for other data.
10. The number of times the connection was cut off because no ACK was returned after several resend attempts.
11. The number of times no ACK was returned within the resend timer set time. (The resend timer sets the maximum time limit between the data being output and ACK being returned.)
12. The number of times no window advertisement is received within the time set on the duration timer. (The duration timer sets the maximum time limit for a window advertisement to be received if the transmission window is smaller than necessary and the resend timer is not set. If no window advertisement is received within the time limit, the number of segments permitted by the transmission window are sent. If the transmission window is set to 0, a window probe (1 octet of data) is sent before the timer restarts.)
13. The number of times no segment was sent or received within the time set on the hold timer.
14. The number of times the hold packet is resent. (Always 0.)
15. The number of times the hold packet is sent without response before the connection is cut off.

## 2) Send Information (40 Bytes)

Ten information items are returned in the following sequence:

1. The total number of packets sent.
2. The number of data packets sent.
3. The number of data bytes sent.
4. The number of data packets resent.
5. The number of data bytes resent.
6. The number of ACK packets sent.
7. The number of window probes (1 octet of data) sent.
8. The number of emergency data packets sent. (Always 0.)
9. The number of window advertisement packets sent.
10. The number of control packets (SYN, FIN, RST) sent.

## 3) Receive Information (84 Bytes)

Twenty-one information items are returned in the following sequence:

1. The total number of packets received.
2. The number of packets received continuously.
3. The number of bytes received continuously.
4. The number of received packets discarded due to an incorrect checksum.
5. The number of packets discarded because the TCP header was smaller than the minimum size for a TCP header or was larger than the IP packet.
6. The number of packets discarded because the TCP header and IP header could not be stored in the first short buffer.
7. The number of resent packets received.



8. The number of bytes in the resend packets.
9. The number of duplicated resend packets received.
10. The number of bytes in the duplicated resend packets received.
11. The number of out-of-range data packets received. (Always 0.)
12. The number of bytes in the out-of-range data packets received. (Always 0.)
13. The number of packets where the data was larger than the window.
14. The number of bytes in the packets where the data was larger than the window.
15. The number of packets received after closing.
16. The number of window probe packets received.
17. The number of resent ACK packets received.
18. The number of ACK packets received with no data set.
19. The number of ACK packets received.
20. The number of ACK packets received for received transmission acknowledgements (ACK).
21. The number of window advertisement packets received.

**UDP Status (Response)**

Three items of UDP information occupying 4 bytes each are returned in the following sequence. Each value is returned as an 8-digit hexadecimal value.

1. The number of packets discarded because the size of the first short buffer was smaller than the minimum size (28) of the IP header and UDP header when the packet was stored.
2. The number of packets discarded due to an incorrect checksum in the UDP header.
3. The number of packets discarded because the IP overall length in the IP header was shorter than the UDP overall length in the UDP header.

**Precautions**

All the above values are set to 0 if network operation stops due to incorrect settings in the system setup.

Counting will be stopped when a count reaches the maximum value. The maximum values are as follows:

IP, ICMP, or UDP status: 7FFFFFFF (2,147,483,647 decimal)  
 TC status: FFFFFFFF (4,294,967,295 decimal)

**Response Codes**

Response code	Description
0000	Normal end
1001	Command too large

**MEMORY STATUS READ**

Reads the status of the network memory for the EtherNet/IP Unit or built-in EtherNet/IP port. The network memory contains 2,991 bytes that are used as required as for communications buffers for communications servicing. The network memory consists of 23,928 short buffers (128 bytes each) and 64 long buffers (1,024 bytes each).

**Command Block**

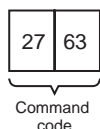

## Response Block

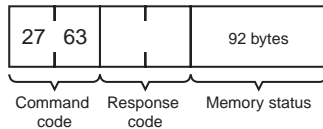

## Parameters

### Memory Status (Response)

A total of 23 data items in six areas are returned in the following order. Each item consists of 4 bytes.

#### **1) Short Buffer Application: Two items are returned (8 bytes).**

1. The number of short buffers currently being used.
2. The number of short buffers in the system (fixed at 23,928 decimal).

#### **2) Short Buffer Application by Type: Thirteen items are returned (52 bytes).**

1. The number of short buffers used for storing communications data
2. The number of short buffers used for protocol headers (TCP, UDP, IP, ICMP, ARP)
3. The number of short buffers used in socket structures
4. The number of short buffers used as protocol control blocks
5. The number of short buffers used for routing tables
6. Not used (always 0)
7. Not used (always 0)
8. The number of short buffers used for IP fragment re-assembly queue headers
9. The number of short buffers used for storing socket addresses
10. Not used (always 0)
11. The number of short buffers used for storing socket options
12. The number of short buffers used for storing access rights
13. The number of short buffers used for storing interface addresses

#### **3) Long Buffer Application: Two items are returned (8 bytes).**

1. The number of long buffers currently being used.
2. The number of long buffers in the system (fixed at 64 decimal).

#### **4) Not Used: Always 0. (4 bytes)**

#### **5) Network Memory Application: Two items are returned (8 bytes).**

1. The number of bytes used (in K bytes)
2. The percentage used

#### **6) Memory Exhaustion Log (12 bytes)**

Counts for the following values indicate a high load on the EtherNet/IP Unit or built-in EtherNet/IP port. These high loads may be caused by problems in communications, particularly FINS communications and UDP sockets. If these values are consistently high, check your applications.

1. The number of times an attempt was made to secure a short buffer without WAIT when there were no short buffers available.
2. The number of times an attempt was made to secure a short buffer with WAIT when there were no short buffers available.
3. The number of times an attempt was made to release and secure a short buffer already being used by another socket when there were no short buffers available.

## Precautions

All the above values are set to 0 if Ethernet communications functions are stopped due to improper settings in the system setup.

These values are cleared when the EtherNet/IP Unit or built-in EtherNet/IP port is started or reset. Values will be counted only until the maximum values are reached.

## Response Codes

Response code	Description
0000	Normal end
1001	Command too large

## SOCKET STATUS READ

Reads the network socket status of the EtherNet/IP Unit or built-in EtherNet/IP port.

### Command Block

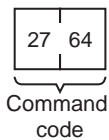

### Response Block

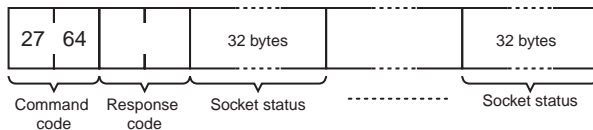

## Parameters

### Socket Status (Response)

Returns eight types of information in records of 32 bytes each. A maximum of 62 records can be returned. The format of each record is shown below.

#### Protocol (4 bytes)

The protocol used for the socket is returned as a number.  
00 00 00 06: TCP; 00 00 00 11: UDP

#### Receive Queue (4 bytes)

The number of bytes in the reception queue.

#### Send Queue (4 bytes)

The number of bytes in the send queue.

#### Local IP Address (4 bytes)

The local IP address allocated to the socket.

#### Local Port Number (4 bytes)

The local port number allocated to the socket.

#### Remote IP Address (4 bytes)

The remote IP address allocated to the socket.

**Remote Port Number (4 bytes)**

The remote port number allocated to the socket.

**TCP Transitions (4 bytes)**

The TCP connection status is returned as one of the numbers shown in the following table. Refer to *Appendix C TCP Status Transitions* for a diagram of transitions.

Number	Stage	Status
00 00 00 00	CLOSED	Closed.
00 00 00 01	LISTEN	Waiting for connection.
00 00 00 02	SYN SENT	SYN sent in active status.
00 00 00 03	SYN RECEIVED	SYN received and sent.
00 00 00 04	ESTABLISHED	Already established.
00 00 00 05	CLOSE WAIT	Received FIN, waiting to close.
00 00 00 06	FIN WAIT 1	Completed and FIN sent.
00 00 00 07	CLOSING	Completed and exchanged FIN. Awaiting ACK.
00 00 00 08	LAST ACK	FIN sent and completed. Awaiting ACK.
00 00 00 09	FIN WAIT 2	Close completed and ACK received. Awaiting FIN.
00 00 00 0A	TIME WAIT	After closing, pauses twice the maximum segment life (2MSL).

**Precautions**

All the above values are set to 0 if Ethernet communications functions are stopped due to improper settings in the system setup.

**Response Codes**

Response code	Description
0000	Normal end
1001	Command too large

**ADDRESS INFORMATION READ**

Reads FINS node addresses and IP addresses

**Command Block**

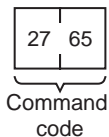

**Response Block**

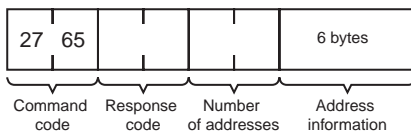

**Parameters**

**Number of Addresses (Response)**

Returns the number of pairs of FINS node addresses and IP addresses. With the EtherNet/IP Unit or built-in EtherNet/IP port, this value is always 0001 (1 decimal).

### Address Information

Returns the FINS node addresses and IP addresses. Each pair requires 6 bytes and has the following configuration.

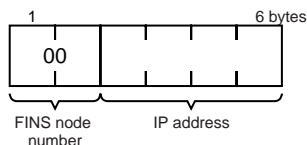

#### FINS Node Address

Node address set in the EtherNet/IP Unit or built-in EtherNet/IP port (hexadecimal).

#### IP Address

IP address set in the EtherNet/IP Unit or built-in EtherNet/IP port (hexadecimal).

### Response Codes

Response code	Description
0000	Normal end
1001	Command too large

### IP ADDRESS READ

Reads the local IP address and subnet mask in the CPU Bus Unit System Setup and the FINS node address. The values read with this command, however, are not necessarily the settings actually used for operation. The settings that are actually used for operation can be confirmed using CONTROLLER DATA READ (page 394) and ADDRESS INFORMATION READ (page 416).

This command is supported for CJ-series EtherNet/IP Units only.

### Command Block

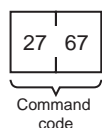

### Response Block

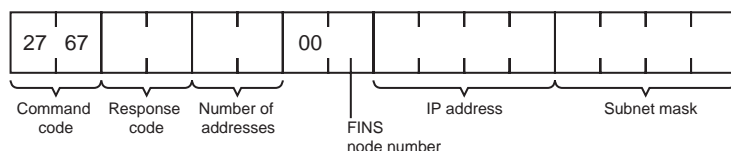

### Parameters

#### Number of Addresses (Response)

The number of sets of FINS node addresses, IP addresses, and subnet masks being returned. The EtherNet/IP Unit or built-in EtherNet/IP port is always 0001 (1 decimal).

#### FINS Node Address (Response)

Node address set on the EtherNet/IP Unit or built-in EtherNet/IP port (hexadecimal).

**IP Address (Response)**

The local IP address set in the CPU Bus Unit System Setup for the EtherNet/IP Unit or built-in EtherNet/IP port is returned in order starting from the leftmost bytes in hexadecimal. If the local IP address set in the allocated words in the DM Area is enabled, 0.0.0.0 is returned.

**Subnet Mask (Response)**

The subnet mask set in the CPU Bus Unit System Setup for the EtherNet/IP Unit or built-in EtherNet/IP port is returned in order starting from the leftmost bytes in hexadecimal.

**Response Codes**

Response code	Description
0000	Normal end
1001	Command too large

**EXPLICIT MESSAGE SEND**

Sends a explicit request message to the specified object, and receives a response.

The rightmost 8 bits of the remote (destination) IP address are used as the remote MAC ID, and the remote IP address is the network ID of the local IP address + the rightmost 8 bits of the remote IP address.

**Command Block**

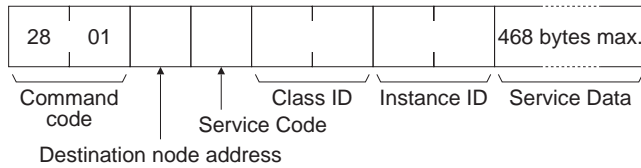

**Response Block**

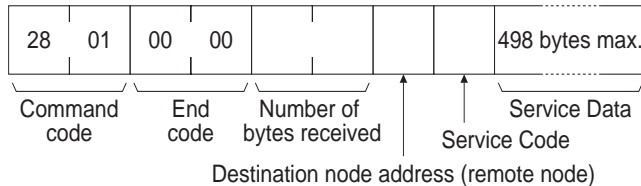

**Response Codes**

Response code	Description
0000	Normal end
0101	The local node's network has not started up.
0105	Local node setting error (A BOOTP errors occurs, and the IP address is undetermined.)
0106	Duplicate address error
0201	The remote node's network has not started up.
0204	Remote node busy, cannot send.
0205	No response returned from remote node. Monitoring timer timed out.
1001	Command length exceeds maximum command length.
1002	Command length is less than minimum command length.
1004	Command block format does not match.
1005	Header error

Response code	Description
110B	Response length exceeds maximum response length.
2211	Unit is busy.

### Description

For details, refer to *EXPLICIT MESSAGE SEND (28 01)* on page 242 in 9-1-1 *Sending Explicit Messages Using CMND(490)*.

## CIP UCMM MESSAGE SEND

Sends a message in the CIP message (UCMM) format.

### Command Block

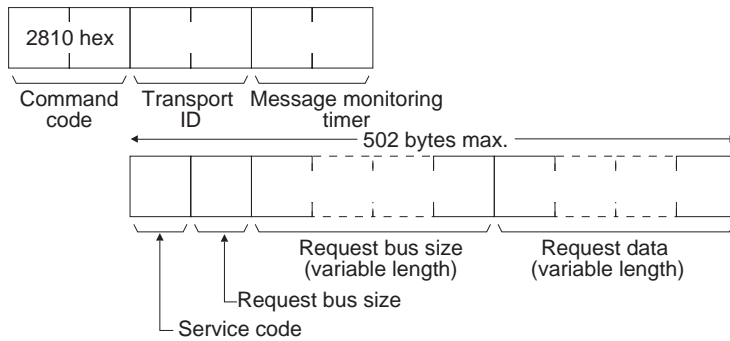

### Response Block

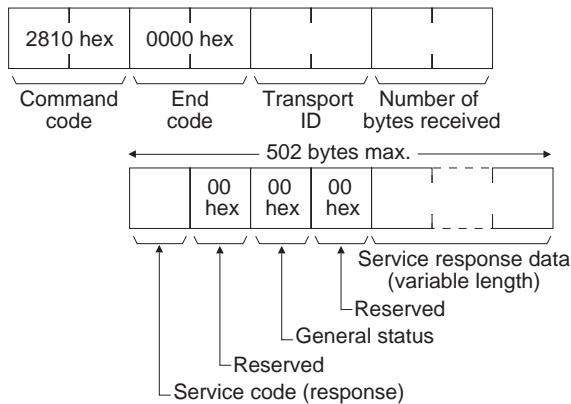

### Response Codes

Response code	Description
0000	Normal end
0101	The local node's network has not started up.
0106	Duplicate address error
0201	The remote node's network has not started up.
0204	Remote node busy, cannot send.
0205	No response returned from remote node. Monitoring timer timed out.
1001	Command length exceeds maximum command length.
1002	Command length is less than minimum command length.
1004	Command block format does not match.

<b>Response code</b>	<b>Description</b>
1005	Header error
110B	Response length exceeds maximum response length.
2211	Unit is busy.

## **Description**

For details, refer to *CIP UCMM MESSAGE SEND (28 10)* on page 238 in *9-1-1 Sending Explicit Messages Using CMND(490)*.



# Appendix F

## EDS File Management

This section explains the EDS file management functions used in the Network Configurator.

### Installing EDS Files

**Note** Using Windows Vista or Windows 7

It is recommended that you start the Network Configurator from *Run as administrator* when you install an EDS file in the Network Configurator. If the EDS file is installed on a Network Configurator that is started in any other way, Windows security user management will cause the installed EDS file to not be recognized when you log in using a different user account. You can run the Network Configurator as the administrator by using the following procedure.

1. Select the Network Configurator from the Start Menu, and then right-click.
2. Select *Run as administrator* from the pop-up menu that is displayed.

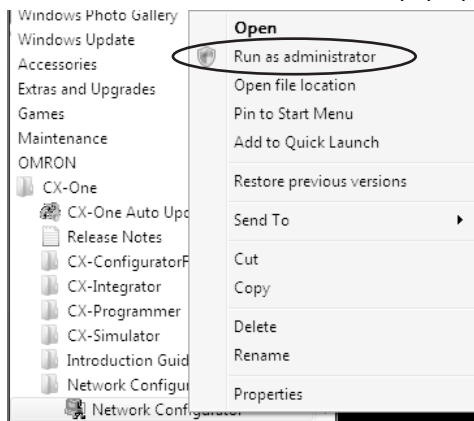

### EDS File - Install

The Network Configurator can support new devices if the proper EDS files are installed. To install the EDS file, use the following procedure.

1. Select EDS File and Install.  
The following window will be displayed.

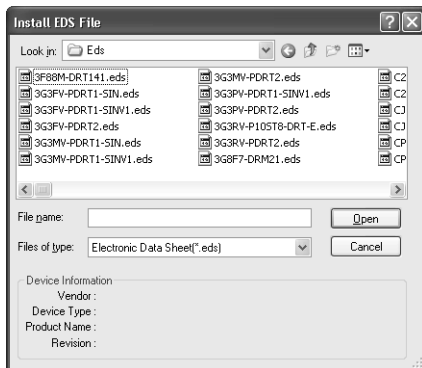

2. The device information will be displayed on the bottom of the window when the EDS file is selected.

3. Select the EDS file to be installed and click the Open Button.  
Next, select the icon file (\*.ico), and the EDS file will be added to the Hardware List.  
If the EDS file already exists, the new EDS file will overwrite the previous one.  
If the hardware versions are different, an EDS file will be added to the Hardware List for each version.

## Creating EDS Files

### EDS File - Create

The EDS files are required by the Network Configurator in order to create a network configuration. To create an EDS file, use the following procedure.

1. Select **EDS File - Create**.
2. Set the device information and I/O information.  
The device information can be obtained from the device on the network if the network is online.
3. The device can be added to the Hardware List as a new device, just like installing an EDS file.

**Note** Device parameters cannot be set with the Network Configurator's EDS file creation function. Obtain a proper EDS file from the manufacturer of the device to make device parameter settings for the device.

## Deleting EDS Files

### EDS File - Delete

To delete an EDS file, use the following procedure.

1. Select the device from the Hardware List.
2. Select **EDS File - Delete**.  
The following confirmation window will be displayed.

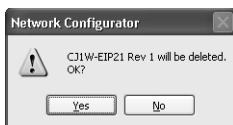

3. Click the **Yes** Button.  
The selected device will be deleted from the Hardware List together with the EDS file.

## Saving EDS Files

### EDS File - Save

To save the EDS file, use the following procedure.

1. Select the device from the Hardware List.
2. Select **EDS file - Save As**.  
The following window will be displayed to specify the name of the folder where the EDS file will be saved and the name of the EDS file.

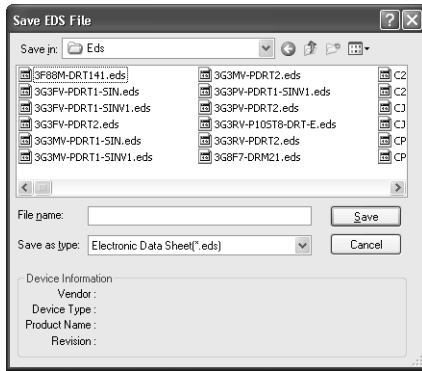

3. Input the folder and file names and click the **Save** Button The EDS file will be saved.

## Searching EDS Files

### EDS File - Search

To search the devices (EDS files) displayed in the Hardware List, use the following procedure.

1. Select **EDS file - Find**.  
The following window will be displayed.



2. Input the character string and click the **Find Next** Button.
3. When there is a matching device found, the cursor will move to that position.
4. To quit the search operation, click the **Cancel** Button.

**Note** (1) The device will be found if it is located below the present cursor position.  
(2) To search all the devices, select *Hardware* in the Hardware List before performing the search procedure.

## Displaying EDS File Properties

### EDS File - Property

To display the properties of the EDS file, use the following procedure.

1. Select the desired hardware (device) from the Hardware List.

2. Select **EDS File - Property**.

The following window will be displayed.

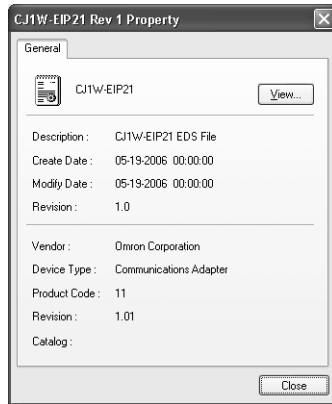

The time and date that the EDS file was created will be displayed, along with the device information.

# Appendix G

## Precautions for Using Windows XP, Vista, or Windows 7

### Changing Windows Firewall Settings

Better firewall security for Windows XP (SP2 or higher), Windows Vista, and Windows 7 has increased the restrictions for data communications on Ethernet ports. When using an EtherNet/IP connection\*1 to one of the following PLCs from an Ethernet port on a computer, you must change the settings of the Windows Firewall to enable using CX-Programmer or Network Configurator communications.

#### Applicable PLCs:

- CJ2H-CPU□□-EIP/CJ2M-CPU3□
- CS1W/CJ1W-EIP□□

\*1 CX-Programmer

- An EtherNet/IP connection includes the following cases:
  - An online connection with the network type set to EtherNet/IP
  - An automatic online connection to a PLC on an EtherNet/IP network when **Auto Online - EtherNet/IP Node Online** is selected from the PLC Menu

Network Configurator

- A connection made by selecting **Option - Select Interface - Ethernet I/F**

**Note** Windows Firewall is mainly designed to prevent inappropriate access from external devices (e.g., via the Internet). The changes to the Windows Firewall settings described in this document enable EtherNet/IP connections to be used by the CX-Programmer. If the same computer is being used on a company network or other network, confirm that the changes will not create security problems before proceeding with the changes. The changes described in this document are required only when you connect using EtherNet/IP through an Ethernet port. No changes are necessary if you are connecting through any other port, such as a USB port.

### Changing Windows Firewall Settings

#### Windows XP

1. When you attempt to connect the CX-Programmer or Network Configurator to a PLC on an EtherNet/IP network through an Ethernet port, the Windows Security Alert Dialog Box will be displayed.
2. Click the Unblock Button.

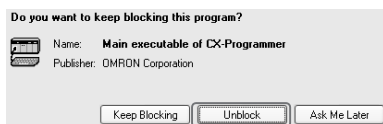

An EtherNet/IP connection will be accepted from CX-Programmer or Network Configurator and EtherNet/IP connections will be enabled in the future as well.

#### Windows Vista or Windows 7

Use the following procedure to change the settings before attempting to connect from the CX-Programmer or Network Configurator.

The User Account Control Dialog Box may be displayed during this procedure. If it appears, click the **Continue** Button and continue with the procedure.

1. Select **Control Panel** from the Windows Start Menu and change the display to Classic View.

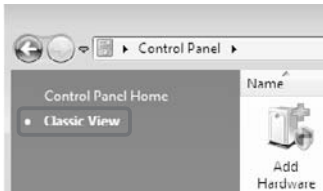

2. Open the *Administrative Tools* and select *Windows Firewall with Advanced Security* from the dialog box that is displayed.

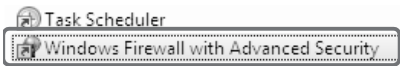

3. Select *Inbound Rules* under *Windows Firewall with Advanced Security on Local Computer* on the left side of the *Windows Firewall with Advanced Security* Dialog Box.

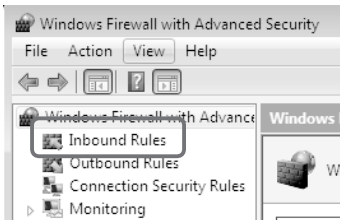

4. Select *New Rule* under *Inbound Rules* in the Actions Area on the right side of the dialog box.



5. Make the following settings for each step in the *New Inbound Rule Wizard* Dialog Box, clicking the **Next** Button to move between steps.

Rule Type	Select Custom.
Program	Select <i>All Programs</i> .
Protocol and Ports	Select ICMPv4 as the protocol type.  <div style="border: 1px solid gray; padding: 5px; width: fit-content;">                     Protocol type: <input type="text" value="ICMPv4"/>                      Protocol number: <input type="text" value="1"/> </div>
Scope	Select <i>Any IP address</i> for everything.
Action	Select <i>Allow the connection</i> .
Profile	Select <i>Domain, Private, and Public</i> .
Name	Enter any name, e.g., Omron_EIP.

6. Click the Finish Button. The rule that you defined will be registered in the Inbound Rules (e.g., Omron\_EIP). Close the *Windows Firewall with Advanced Security* Dialog Box.



7. When you attempt to connect the CX-Programmer or Network Configurator to a PLC on an EtherNet/IP network through an Ethernet port, the Windows Security Alert Dialog Box will be displayed.
8. Click the **Unblock** Button.

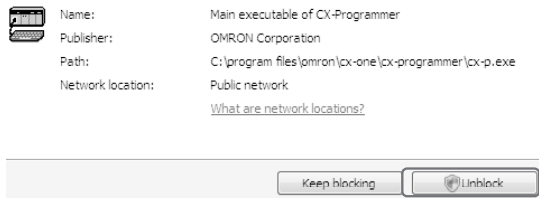

An EtherNet/IP connection will be accepted from CX-Programmer or Network Configurator and EtherNet/IP connections will be enabled in the future as well.





# Appendix H

## Setting Example for Using Tag Data Links with the CJ2M

The maximum link data size per node for tag data links with built-in EtherNet/IP ports on CJ2M-CPU3□ CPU Units depends on the unit version.

Use the following setting examples as reference.

### Correct Tag Data Link Setting Examples

#### Setting Example 1

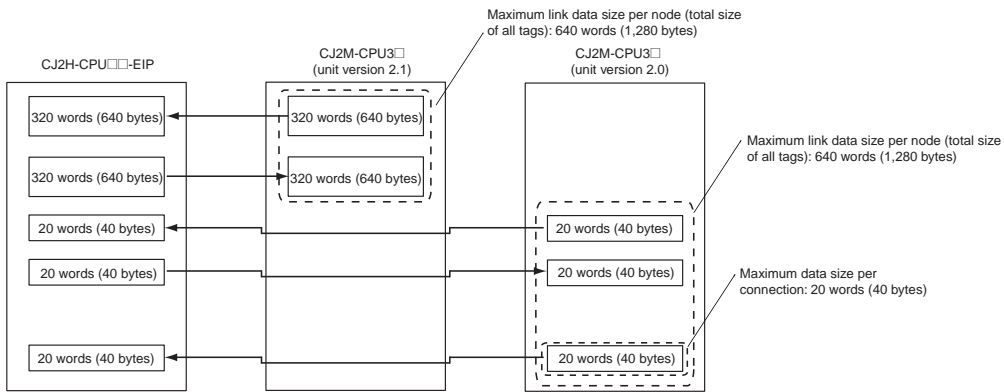

#### Setting Example 2

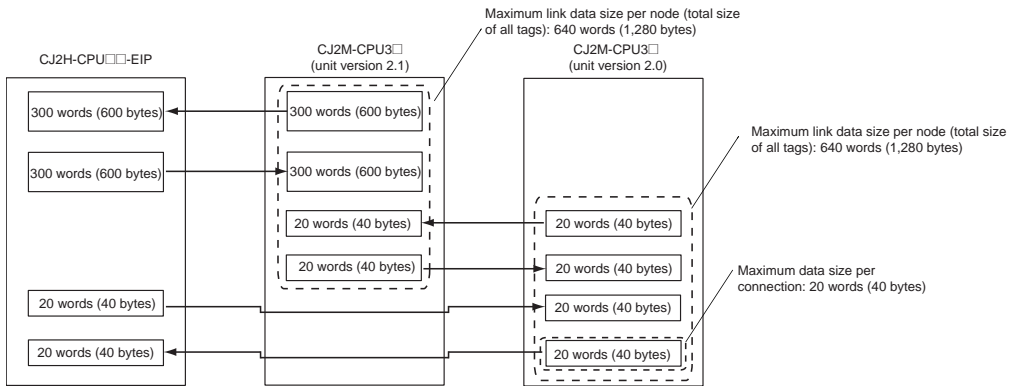

# Incorrect Tag Data Link Setting Examples

## Setting Example 1

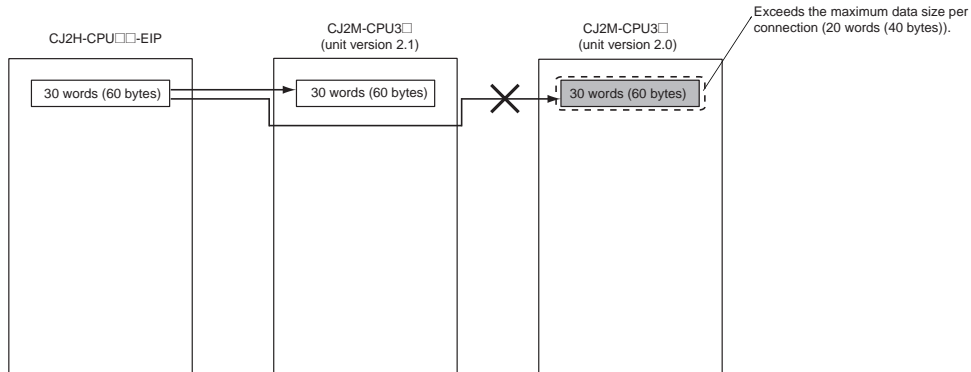

## Setting Example 2

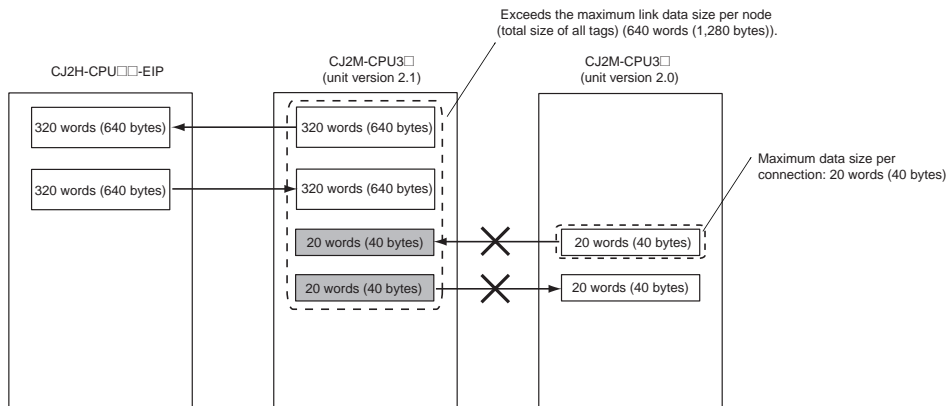

# Index

## Numerics

7-segment display, 25

## A

*Adjust Time* field, 328, 330

alternate DNS server, 54

applications

precautions, xxvi

*Auto Adjust Time* field, 328, 329

Auto Adjust Time Tab, 328, 329

automatic clock adjustment

Automatic Clock Adjustment Switch, 330

errors

error codes, 330

error log, 330

SNTP, 330

overview, 326

procedure, 327

requirements, 326

settings, 328

specifications, 327

Auxiliary Area

related data, 90

## B

Backup Tool, 338

bandwidth usage

relationship to packet interval (RPI), 265

baud rate, 55, 270

CJ-series, 15, 16

CS-series, 14

bits

Automatic Clock Adjustment Switch, 330

boots

recommended models, 29

BROADCAST DATA SEND, 399

broadcast test

command, 399

reading results, 399

BROADCAST TEST RESULTS READ, 399

buffers, 379, 413

bye command, 305, 310, 314

## C

cables

connections, 44

installation, 43

precautions, 41

cd command, 305, 310, 312

cdup command, 305, 310

CIDR, 3, 96

CIO Area

allocations, 72

CIP, 3, 383

CIP communications services, 6

CIP message communications., 383

cleaning, 334

close command, 305, 310, 314

CMND(490) instruction, 192, 222, 226

commands

FTP commands, 310

communications

high traffic conditions, 234

message communications, 189, 235

message communications errors, 197

communications cables, xxvii

Communications Port Enabled Flags, 228

Communications Port Error Flags, 228

communications specifications, 17

Communications Status 1 Flags, 79

Communications Status 2 Flags, 81

Communications Status 3 Flags, 81

communications test, 66

component names, 22

connecting to the FTP server, 306

connection

setting, 143

Connections settings (Edit All Connections), 146

Connections Tab, 143

connectors (modular plug)

recommended models, 29

Contact Output Units

precautions, 43

control bits, 73

CONTROLLER DATA READ, 394

CONTROLLER STATUS READ, 396

CPU Bus Units

precautions, xxviii

- creating a tag set, 129
- creating tag sets, 129
- creating tags, 130
- crimp terminals, xxvii
- current consumption
  - CJ-series, 15, 16
  - CS-series, 14
- CX-Integrator, 46
  - creating routing tables, 210
- CX-Programmer, 8, 46
  - connecting to PLC, 213
- cyclic communications
  - required settings, 35

## D

- Datalink Tool, 58
- default gateway, 54
- delays
  - message service delays, 296
- delete command, 305, 310, 314
- Device Monitor function, 342
- device parameters
  - clearing, 178
  - editing, 129
- devices
  - registering, 127
- DHCP client computer, 104
- DHCP service
  - automatic IP address setting by DHCP service, 104
- dimensions
  - CJ-series, 15, 16, 19, 20
  - CS-series, 14, 19
- dir command, 305, 310, 311
- distance
  - CJ-series transmission distance, 15, 16
  - transmission distance, 14
- DM Area
  - allocations, 85
- DNS server, 54
  - automatic clock adjustment
    - errors, 330
- DNS Tab, 328
- domain name, 55
- downloading tag data link parameters, 170
- dynamic changes of remote IP address
  - prohibiting, 101

## E

- EC Directives, xxviii
- Edit Parameters, 52, 62
- EDS file management, 421
- EDS files, 10, 421
  - creating, 422
  - installing, 421
  - saving, 422
  - searching, 423
- electromagnetic fields, xxvi
- EM File Memory, 317
  - using, 317
- EMC Directives, xxviii
- EMI Standard, xxviii
- EMS Standard, xxviii
- EPATH type, 385
- error codes
  - table of error codes, 367
- error flags
  - Target Node PLC Error Flags, 75, 89
- error log
  - clearing, 366
  - codes, 367
  - overflow, 366
  - specifications, 366
- ERROR LOG CLEAR, 401
- error log function, 366
- ERROR LOG READ, 400
- error processing, 341
- errors
  - automatic clock adjustment, 330
  - controller status, 396
  - error log
    - clearing, 401
    - reading, 400
  - error messages, 315
  - flags
    - FINS communications, 396
    - message communications, 196, 197
- Ethernet communications
  - addresses
    - reading from Unit, 394
  - network parameters, 377
  - parameters, 377, 379
- Ethernet Connectors, 44
- Ethernet Units
  - reading status, 413
- EtherNet/IP Datalink Tool, 58

EtherNet/IP Unit Features, 2  
EtherNet/IP Units  
  resetting, 393  
ETN11-compatible mode, 101  
explicit message communications, 189, 235  
explicit message communications service, 108, 110  
explicit messages  
  list of PLC object services, 250  
  receiving, 249  
  sending, 236  
  sending using CMND(490), 244

## **F**

FALS instruction, xxv  
FINS communications, 235  
  overview, 8  
  specifications, 201, 222  
  testing, 401  
FINS communications service, 108, 109  
FINS communications services, 96  
FINS message communications, 189, 192  
FINS node address  
  relationship to IP address, 96, 107  
FINS response codes  
  troubleshooting with response codes, 373  
FINS/TCP, 204  
  communications, 206  
  connection numbers, 205  
  connection status, 206  
  features, 204  
  frame format, 205  
  procedure, 207  
  TCP port number, 205  
FINS/TCP communications method, 102  
FINS/TCP Connection Status Flags, 83  
FINS/UDP, 202  
  frame format, 202  
  procedure, 203  
  UDP port numbers, 203  
FINS/UDP and FINS/TCP  
  comparison, 201  
FINS/UDP communications methods, 98  
FinsGateway, 217  
flags  
  Error Flags, 396  
  FTP Status Flag, 316  
FTP, 3, 63, 304  
FTP server  
  application examples, 309  
  commands, 310  
    bye, 314  
    cd, 312  
    close, 314  
    delete, 314  
    dir, 311  
    get, 313  
    ls, 311  
    mdelete, 314  
    mget, 313  
    mput, 313  
    open, 310  
    put, 313  
    pwd, 312  
    quitting, 314  
    type, 313  
    user, 311  
  connecting, 306, 310  
  data type, 313  
  displaying current directory, 312  
  file types, 305  
  protection, 305  
  protocol, 305  
  quitting, 314  
  *See also* Memory Cards  
  specifications, 305  
  status, 316  
FTP Status Flag, 316  
full duplex, 55

## **G**

gateway  
  default gateway, 54  
  general specifications, 14  
  get command, 305, 310, 313, 322  
  *Get the time information from the Sntp server field*, 328, 329  
  global address, 108  
GMRP, 30

## **H**

half duplex, 55  
high communications traffic  
  preventing, 234  
host name, 54

*Host name* field, 328, 329

## I

I/O allocations

    CIO Area, 72

    DM Area, 85

I/O memory address, 118

I/O response time, 285

I/O tables

    creating, 46

    overview, 46

ICMP communications

    status, 410

IGMP snooping, 30

importing, 138

indicators, 24

    using LED indicators for troubleshooting, 349

initial settings, 34

installation, 33

    cable connections, 44

    location, xxvi

    mounting Unit to PLC, 38

    precautions, 41

INTERNODE ECHO TEST, 398

internode test

    command, 398

IP address, 54, 94

    automatic generation, 97

    automatic generation (dynamic), 98

    automatic generation (static), 99

    automatic IP address setting by DHCP service, 104

    combined method, 100

    determining IP addresses, 94

    global address, 108

    IP address table method, 97, 99

    private address, 108

    prohibiting dynamic changes of remote IP address, 101

    relationship to FINS node address, 96, 107

    responding to computers with changed IP address, 104

IP Address Display/Setting Area, 85

*IP Address* field, 328, 329

IP ADDRESS TABLE READ, 407

IP addresses

    allocating, 94

    configuration, 94

IP communications

    IP addresses

        reading from Units, 394

        reading tables, 407

    IP router tables

        reading, 408

        status, 410

IP ROUTER TABLE READ, 408

## L

ladder programming for tag data links, 185

LED indicators, 24

    using for troubleshooting, 349

link setting (baud rate), 55

local network table, 209

locking devices

    precautions, xxvii

*Login* field, 308

Low Voltage Directive, xxviii

ls command, 305, 310, 311

## M

maintenance, 334

maximum tag data link I/O response time, 288

mdelete command, 305, 310, 314

memory allocation, 70

Memory Card, 336

    restoring data, 337

Memory Cards, 305, 317

    deleting files, 314

    displaying directories, 311

*See also* FTP server

    transferring files from host, 313

    transferring files to host, 313

MEMORY STATUS READ, 413

message communications, 7, 235

    errors, 196

    specifications, 195

message communications functions, 189

message communications service

    required settings, 35

mget command, 305, 310, 313

mkdir command, 305, 310

mode settings

    reading from Unit, 394

mounting procedure, 39

mput command, 305, 310, 313

MS indicator, 24

multicast communications, 116

multicast filter, 30

## N

n

beginning word of allocated CIO Area, 72

network

devices required for constructing a network, 4

network configuration file

reading, 180

saving, 179

Network Configurator, 123

connecting to the network, 163

Device Monitor function, 342

requirements, 10

starting, 123

TCP/IP settings, 56

Network Configurator overview, 10

network devices

recommended devices, 29

networks

network memory, 413

network parameters, 377

Node Address Setting Switch, 28

node addresses

setting, 36, 37

noise, xxvi

Contact Output Units, 43

reducing, 41

nomenclature and functions, 22

Normal Target Node Flags, 83, 88

NS indicator, 24

## O

online editing, xxv

open command, 305, 310

operating environment

precautions, xxvi

## P

packet interval (RPI)

relationship to bandwidth usage, 265

setting, 264

*Password* field, 308

PCMR(260) instruction, 229

PING, 401

PING command, 66

PLC object services, 250

*Port No.* field, 308, 328, 329

port numbers

UDP port

reading from Unit, 394

power supply, xxvi

precautions, xxvii

precautions, xxiii

applications, xxvi

Contact Output Units, 43

general, xxiv

handling, 40

installation, 41

operating environment, xxvii

power supply, xxvii

safety, xxiv

wiring, 44

preferred DNS server, 54

private address, 108

Programming Console, 46

Programming Devices

connecting, 46

CX-Net, 46

CX-Programmer, 46

Programming Console, 46

PROTOCOL STATUS READ, 409

protocols

FTP server, 305

reading status, 409

put command, 305, 310, 313, 322

pwd command, 305, 310, 312

## Q

QoS, 30

quit command, 305, 310, 314

## R

radioactivity, xxvi

receiving explicit messages, 249

recommended network devices, 29

recommended products, 41

RECV(098) instruction, 192, 222, 225

accessible data areas, 223

delays, 299

- refresh cycle, 270
- Register Device List, 143
- Registered Target Node Flags, 83, 87
- registering devices, 127, 143
- relay tables, 209
- rename command, 305, 310
- replacing a Unit, 334
- replacing Units
  - precautions, xxvii
- restoring data from the Memory Card, 337
- Retry timer* field, 328, 330
- rmdir command, 305, 310
- route path, 385
- routing tables, 209
  - precautions, xxviii
  - relay network table, 209
  - setting examples, 211

## S

- safety precautions, xxiv
- SEND(090) instruction, 192, 222, 224
  - accessible data areas, 223
  - delays, 296
- sending explicit messages, 244
- Server specification type* field, 328, 329
- Setup Tab, 308
- seven-segment Display, 25
- seven-segment display
  - error status, 349, 353, 355, 357, 360
- short-circuits
  - precautions, xxvii
- Simple Backup Function, 335
- SNMP, 3, 65
- SNMP trap, 65
- SNTP, 3, 64, 326
- SNTP server
  - automatic clock adjustment
  - errors, 330
  - obtaining clock information, 326
- SOCKET STATUS READ, 381, 415
- sockets
  - reading status, 415
  - TCP sockets
    - status, 381
  - testing communications, 401
- specifications, 14

- CJ-series general specifications, 15, 16
- communications specifications, 17
- CS-series general specifications, 14
- FINS communications, 222
- FTP server, 305
- message communications, 195
- Network Configurator, 10
- startup procedure, 34
- static electricity, xxvi
  - precautions, xxvii
- status
  - reading memory status, 413
  - reading protocol status, 409
  - reading socket status, 415
- status flags for tag data links, 188
- subnet mask, 95
- subnet masks, 54
  - reading from Unit, 394
- switch
  - Node Address Setting Switch, 28
- switching hub
  - connection methods, 42
  - environment precautions, 42
  - functions, 30
  - precautions when selecting, 30
  - recommended models, 29
- switching hub types, 29
- SYSMAC BUS/2, 222
- SYSMAC LINK, 222

## T

- tag data link parameters
  - downloading, 114, 170
  - setting, 114
  - uploading, 173
  - verifying, 174
- Tag Data Link Start Bit, 74
- Tag Data Link Stop Bit, 74
- tag data links
  - checking bandwidth usage, 271
  - data areas, 118
  - delay time, 267
  - functions, 117
  - I/O response time, 285
  - ladder programming, 185
  - maximum I/O response time, 288
  - overview, 114
  - required settings, 35



- specifications, 117
- status flags, 188
- tag data links (cyclic communications), 6
- tag set, 118
- tag sets
  - creating, 129
- Target Node PLC Error Flags, 75, 89
- Target Node PLC Operating Flags, 75, 89
- TCP communications
  - sockets
    - status, 381
    - status, 411
- TCP status transitions, 381
- TCP/IP, 52
- terminal blocks, xxv
- timeout errors, 373
- timers, 379
- to, 62
- troubleshooting, 370
- twisted-pair cable
  - recommended models, 29
- twisted-pair cables
  - precautions, 41
- type command, 305, 310, 313

## U

- unicast communications, 116
- unit numbers
  - setting, 36, 37
- Unit replacement, 334
- unit setup, 4, 62
- Unit Status 1 Flags, 75
- Unit Status 2 Flags, 77
- Unregister Device List, 144
- uploading tag data link parameters, 173
- user command, 305, 310, 311
- user name
  - specifying, 311
- User Settings Area, 87
- using FTP commands, 310

## V

- verifying tag data link parameters, 174

## W

- wiring
  - precautions, 44



## Revision History

A manual revision code appears as a suffix to the catalog number on the front cover of the manual.

Cat. No. W465-E1-07

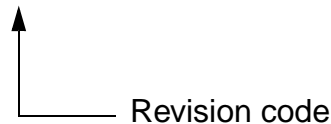

The following table outlines the changes made to the manual during each revision. Page numbers refer to the previous version.

Revision code	Date	Revised content
01	June 2007	Original production
02	July 2008	Added information for CJ-series CJ2 CPU Units and for new unit version 2.0 functions.
03	December 2008	Added the CJ-series CJ2 CPU Units (CJ2H-CPU□□).
04	December 2009	Added information on methods to create connections and heartbeats. Greatly changed the structure of sections 1 and 2. Added and improved information on communications performance and communications load in section 10. Made changes accompanying a new version of the Network Configurator (V3.10).
05	February 2010	Added the CJ-series CJ2M CPU Units (CJ2M-CPU3□).
06	October 2010	Added information on functions for unit version 2.1 of the CJ-series CJ2M CPU Units (CJ2M-CPU3□).
07	October 2012	Added information on functions for unit version 2.1 of the EtherNet/IP Unit (and built-in EtherNet/IP port).

---

*Revision History*

---

# Terms and Conditions of Sale

1. **Offer; Acceptance.** These terms and conditions (these "**Terms**") are deemed part of all quotes, agreements, purchase orders, acknowledgments, price lists, catalogs, manuals, brochures and other documents, whether electronic or in writing, relating to the sale of products or services (collectively, the "**Products**") by Omron Electronics LLC and its subsidiary companies ("**Omron**"). Omron objects to any terms or conditions proposed in Buyer's purchase order or other documents which are inconsistent with, or in addition to, these Terms.
2. **Prices; Payment Terms.** All prices stated are current, subject to change without notice by Omron. Omron reserves the right to increase or decrease prices on any unshipped portions of outstanding orders. Payments for Products are due net 30 days unless otherwise stated in the invoice.
3. **Discounts.** Cash discounts, if any, will apply only on the net amount of invoices sent to Buyer after deducting transportation charges, taxes and duties, and will be allowed only if (i) the invoice is paid according to Omron's payment terms and (ii) Buyer has no past due amounts.
4. **Interest.** Omron, at its option, may charge Buyer 1-1/2% interest per month or the maximum legal rate, whichever is less, on any balance not paid within the stated terms.
5. **Orders.** Omron will accept no order less than \$200 net billing.
6. **Governmental Approvals.** Buyer shall be responsible for, and shall bear all costs involved in, obtaining any government approvals required for the importation or sale of the Products.
7. **Taxes.** All taxes, duties and other governmental charges (other than general real property and income taxes), including any interest or penalties thereon, imposed directly or indirectly on Omron or required to be collected directly or indirectly by Omron for the manufacture, production, sale, delivery, importation, consumption or use of the Products sold hereunder (including customs duties and sales, excise, use, turnover and license taxes) shall be charged to and remitted by Buyer to Omron.
8. **Financial.** If the financial position of Buyer at any time becomes unsatisfactory to Omron, Omron reserves the right to stop shipments or require satisfactory security or payment in advance. If Buyer fails to make payment or otherwise comply with these Terms or any related agreement, Omron may (without liability and in addition to other remedies) cancel any unshipped portion of Products sold hereunder and stop any Products in transit until Buyer pays all amounts, including amounts payable hereunder, whether or not then due, which are owing to it by Buyer. Buyer shall in any event remain liable for all unpaid accounts.
9. **Cancellation; Etc.** Orders are not subject to rescheduling or cancellation unless Buyer indemnifies Omron against all related costs or expenses.
10. **Force Majeure.** Omron shall not be liable for any delay or failure in delivery resulting from causes beyond its control, including earthquakes, fires, floods, strikes or other labor disputes, shortage of labor or materials, accidents to machinery, acts of sabotage, riots, delay in or lack of transportation or the requirements of any government authority.
11. **Shipping; Delivery.** Unless otherwise expressly agreed in writing by Omron:
  - a. Shipments shall be by a carrier selected by Omron; Omron will not drop ship except in "break down" situations.
  - b. Such carrier shall act as the agent of Buyer and delivery to such carrier shall constitute delivery to Buyer;
  - c. All sales and shipments of Products shall be FOB shipping point (unless otherwise stated in writing by Omron), at which point title and risk of loss shall pass from Omron to Buyer; provided that Omron shall retain a security interest in the Products until the full purchase price is paid;
  - d. Delivery and shipping dates are estimates only; and
  - e. Omron will package Products as it deems proper for protection against normal handling and extra charges apply to special conditions.
12. **Claims.** Any claim by Buyer against Omron for shortage or damage to the Products occurring before delivery to the carrier must be presented in writing to Omron within 30 days of receipt of shipment and include the original transportation bill signed by the carrier noting that the carrier received the Products from Omron in the condition claimed.
13. **Warranties.** (a) **Exclusive Warranty.** Omron's exclusive warranty is that the Products will be free from defects in materials and workmanship for a period of twelve months from the date of sale by Omron (or such other period expressed in writing by Omron). Omron disclaims all other warranties, express or implied. (b) **Limitations.** OMRON MAKES NO WARRANTY OR REPRESENTATION, EXPRESS OR IMPLIED, ABOUT NON-INFRINGEMENT, MERCHANTABILITY OR FITNESS FOR A PARTICULAR PURPOSE OF THE PRODUCTS. BUYER ACKNOWLEDGES THAT IT ALONE HAS DETERMINED THAT THE PRODUCTS WILL SUITABLY MEET THE REQUIREMENTS OF THEIR INTENDED USE. Omron further disclaims all warranties and responsibility of any type for claims or expenses based on infringement by the Products or otherwise of any intellectual property right. (c) **Buyer Remedy.** Omron's sole obligation hereunder shall be, at Omron's election, to (i) replace (in the form originally shipped with Buyer responsible for labor charges for removal or replacement thereof) the non-complying Product, (ii) repair the non-complying Product, or (iii) repay or credit Buyer an amount equal to the purchase price of the non-complying Product; provided that in no event shall Omron be responsible for warranty, repair, indemnity or any other claims or expenses regarding the Products unless Omron's analysis confirms that the Products were properly handled, stored, installed and maintained and not subject to contamination, abuse, misuse or inappropriate modification. Return of any Products by Buyer must be approved in writing by Omron before shipment. Omron Companies shall not be liable for the suitability or unsuitability or the results from the use of Products in combination with any electrical or electronic components, circuits, system assemblies or any other materials or substances or environments. Any advice, recommendations or information given orally or in writing, are not to be construed as an amendment or addition to the above warranty. See <http://www.omron247.com> or contact your Omron representative for published information.
14. **Limitation on Liability; Etc.** OMRON COMPANIES SHALL NOT BE LIABLE FOR SPECIAL, INDIRECT, INCIDENTAL, OR CONSEQUENTIAL DAMAGES, LOSS OF PROFITS OR PRODUCTION OR COMMERCIAL LOSS IN ANY WAY CONNECTED WITH THE PRODUCTS, WHETHER SUCH CLAIM IS BASED IN CONTRACT, WARRANTY, NEGLIGENCE OR STRICT LIABILITY. Further, in no event shall liability of Omron Companies exceed the individual price of the Product on which liability is asserted.
15. **Indemnities.** Buyer shall indemnify and hold harmless Omron Companies and their employees from and against all liabilities, losses, claims, costs and expenses (including attorney's fees and expenses) related to any claim, investigation, litigation or proceeding (whether or not Omron is a party) which arises or is alleged to arise from Buyer's acts or omissions under these Terms or in any way with respect to the Products. Without limiting the foregoing, Buyer (at its own expense) shall indemnify and hold harmless Omron and defend or settle any action brought against such Companies to the extent based on a claim that any Product made to Buyer specifications infringed intellectual property rights of another party.
16. **Property; Confidentiality.** Any intellectual property in the Products is the exclusive property of Omron Companies and Buyer shall not attempt to duplicate it in any way without the written permission of Omron. Notwithstanding any charges to Buyer for engineering or tooling, all engineering and tooling shall remain the exclusive property of Omron. All information and materials supplied by Omron to Buyer relating to the Products are confidential and proprietary, and Buyer shall limit distribution thereof to its trusted employees and strictly prevent disclosure to any third party.
17. **Export Controls.** Buyer shall comply with all applicable laws, regulations and licenses regarding (i) export of products or information; (ii) sale of products to "forbidden" or other proscribed persons; and (iii) disclosure to non-citizens of regulated technology or information.
18. **Miscellaneous.** (a) **Waiver.** No failure or delay by Omron in exercising any right and no course of dealing between Buyer and Omron shall operate as a waiver of rights by Omron. (b) **Assignment.** Buyer may not assign its rights hereunder without Omron's written consent. (c) **Law.** These Terms are governed by the law of the jurisdiction of the home office of the Omron company from which Buyer is purchasing the Products (without regard to conflict of law principles). (d) **Amendment.** These Terms constitute the entire agreement between Buyer and Omron relating to the Products, and no provision may be changed or waived unless in writing signed by the parties. (e) **Severability.** If any provision hereof is rendered ineffective or invalid, such provision shall not invalidate any other provision. (f) **Setoff.** Buyer shall have no right to set off any amounts against the amount owing in respect of this invoice. (g) **Definitions.** As used herein, "including" means "including without limitation"; and "Omron Companies" (or similar words) mean Omron Corporation and any direct or indirect subsidiary or affiliate thereof.

## Certain Precautions on Specifications and Use

1. **Suitability of Use.** Omron Companies shall not be responsible for conformity with any standards, codes or regulations which apply to the combination of the Product in the Buyer's application or use of the Product. At Buyer's request, Omron will provide applicable third party certification documents identifying ratings and limitations of use which apply to the Product. This information by itself is not sufficient for a complete determination of the suitability of the Product in combination with the end product, machine, system, or other application or use. Buyer shall be solely responsible for determining appropriateness of the particular Product with respect to Buyer's application, product or system. Buyer shall take application responsibility in all cases but the following is a non-exhaustive list of applications for which particular attention must be given: (i) Outdoor use, uses involving potential chemical contamination or electrical interference, or conditions or uses not described in this document. (ii) Use in consumer products or any use in significant quantities. (iii) Energy control systems, combustion systems, railroad systems, aviation systems, medical equipment, amusement machines, vehicles, safety equipment, and installations subject to separate industry or government regulations. (iv) Systems, machines and equipment that could present a risk to life or property. Please know and observe all prohibitions of use applicable to this Product. NEVER USE THE PRODUCT FOR AN APPLICATION INVOLVING SERIOUS RISK TO LIFE OR PROPERTY OR IN LARGE QUANTITIES WITHOUT ENSURING THAT THE SYSTEM AS A WHOLE HAS BEEN DESIGNED TO ADDRESS THE RISKS, AND THAT THE OMRON'S PRODUCT IS PROPERLY RATED AND INSTALLED FOR THE INTENDED USE WITHIN THE OVERALL EQUIPMENT OR SYSTEM.
2. **Programmable Products.** Omron Companies shall not be responsible for the user's programming of a programmable Product, or any consequence thereof.
3. **Performance Data.** Data presented in Omron Company websites, catalogs and other materials is provided as a guide for the user in determining suitability and does not constitute a warranty. It may represent the result of Omron's test conditions, and the user must correlate it to actual application requirements. Actual performance is subject to the Omron's Warranty and Limitations of Liability.
4. **Change in Specifications.** Product specifications and accessories may be changed at any time based on improvements and other reasons. It is our practice to change part numbers when published ratings or features are changed, or when significant construction changes are made. However, some specifications of the Product may be changed without any notice. When in doubt, special part numbers may be assigned to fix or establish key specifications for your application. Please consult with your Omron's representative at any time to confirm actual specifications of purchased Product.
5. **Errors and Omissions.** Information presented by Omron Companies has been checked and is believed to be accurate; however, no responsibility is assumed for clerical, typographical or proofreading errors or omissions.

**OMRON INDUSTRIAL AUTOMATION • THE AMERICAS HEADQUARTERS**

Schaumburg, IL USA • 847.843.7900 • 800.556.6766 • [www.omron247.com](http://www.omron247.com)

---

**OMRON CANADA, INC. • HEAD OFFICE**

Toronto, ON, Canada • 416.286.6465 • 866.986.6766 • [www.omron247.com](http://www.omron247.com)

**OMRON ELECTRONICS DE MEXICO • HEAD OFFICE**

México DF • 52.55.59.01.43.00 • 001.800.556.6766 • [mela@omron.com](mailto:mela@omron.com)

**OMRON ELECTRONICS DE MEXICO • SALES OFFICE**

Apodaca, N.L. • 52.81.11.56.99.20 • 001.800.556.6766 • [mela@omron.com](mailto:mela@omron.com)

**OMRON ELETRÔNICA DO BRASIL LTDA • HEAD OFFICE**

São Paulo, SP, Brasil • 55.11.2101.6300 • [www.omron.com.br](http://www.omron.com.br)

**OMRON ARGENTINA • SALES OFFICE**

Cono Sur • 54.11.4783.5300

**OMRON CHILE • SALES OFFICE**

Santiago • 56.9.9917.3920

**OTHER OMRON LATIN AMERICA SALES**

54.11.4783.5300

---

**OMRON EUROPE B.V.** • Wegalaan 67-69, NL-2132 JD, Hoofddorp, The Netherlands. • Tel: +31 (0) 23 568 13 00

Fax: +31 (0) 23 568 13 88 • [www.industrial.omron.eu](http://www.industrial.omron.eu)