

## Smart Camera FQ2

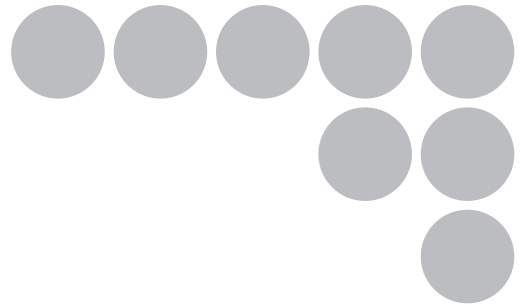

## User's Manual



# Introduction

---

Thank you for purchasing the FQ2.

This manual provides information regarding functions, performance and operating methods that are required for using the FQ2.

When using the FQ2, be sure to observe the following:

- The FQ2 must be operated by personnel knowledgeable in electrical engineering.
- To ensure correct use, please read this manual thoroughly to deepen your understanding of the product.
- Please keep this manual in a safe place so that it can be referred to whenever necessary.

# User's Manual

APPLICATION CONSIDERATIONS  
(Please Read)

Introduction

1

Installation and Connections

2

Taking Images

3

Setting Up Inspections

4

Testing and Saving Settings

5

Operation

6

Convenient Functions

7

Controlling Operation and Outputting  
Data with a Parallel Connection

8

Connecting through Ethernet

9

Connecting with RS-232C

10

Troubleshooting

11

Appendices

12

## **READ AND UNDERSTAND THIS DOCUMENT**

Please read and understand this document before using the products. Please consult your OMRON representative if you have any questions or comments.

## **WARRANTY**

OMRON's exclusive warranty is that the products are free from defects in materials and workmanship for a period of one year (or other period if specified) from date of sale by OMRON.

OMRON MAKES NO WARRANTY OR REPRESENTATION, EXPRESS OR IMPLIED, REGARDING NON-INFRINGEMENT, MERCHANTABILITY, OR FITNESS FOR PARTICULAR PURPOSE OF THE PRODUCTS. ANY BUYER OR USER ACKNOWLEDGES THAT THE BUYER OR USER ALONE HAS DETERMINED THAT THE PRODUCTS WILL SUITABLY MEET THE REQUIREMENTS OF THEIR INTENDED USE. OMRON DISCLAIMS ALL OTHER WARRANTIES, EXPRESS OR IMPLIED.

## **LIMITATIONS OF LIABILITY**

OMRON SHALL NOT BE RESPONSIBLE FOR SPECIAL, INDIRECT, OR CONSEQUENTIAL DAMAGES, LOSS OF PROFITS OR COMMERCIAL LOSS IN ANY WAY CONNECTED WITH THE PRODUCTS, WHETHER SUCH CLAIM IS BASED ON CONTRACT, WARRANTY, NEGLIGENCE, OR STRICT LIABILITY.

In no event shall responsibility of OMRON for any act exceed the individual price of the product on which liability is asserted.

IN NO EVENT SHALL OMRON BE RESPONSIBLE FOR WARRANTY, REPAIR, OR OTHER CLAIMS REGARDING THE PRODUCTS UNLESS OMRON'S ANALYSIS CONFIRMS THAT THE PRODUCTS WERE PROPERLY HANDLED, STORED, INSTALLED, AND MAINTAINED AND NOT SUBJECT TO CONTAMINATION, ABUSE, MISUSE, OR INAPPROPRIATE MODIFICATION OR REPAIR.

## **SUITABILITY FOR USE**

THE PRODUCTS CONTAINED IN THIS DOCUMENT ARE NOT SAFETY RATED. THEY ARE NOT DESIGNED OR RATED FOR ENSURING SAFETY OF PERSONS, AND SHOULD NOT BE RELIED UPON AS A SAFETY COMPONENT OR PROTECTIVE DEVICE FOR SUCH PURPOSES.

Please refer to separate catalogs for OMRON's safety rated products.

OMRON shall not be responsible for conformity with any standards, codes, or regulations that apply to the combination of products in the customer's application or use of the product.

At the customer's request, OMRON will provide applicable third party certification documents identifying ratings and limitations of use that apply to the products. This information by itself is not sufficient for a complete determination of the suitability of the products in combination with the end product, machine, system, or other application or use.

The following are some examples of applications for which particular attention must be given. This is not intended to be an exhaustive list of all possible uses of the products, nor is it intended to imply that the uses listed may be suitable for the products:

- Outdoor use, uses involving potential chemical contamination or electrical interference, or conditions or uses not described in this document.



- Nuclear energy control systems, combustion systems, railroad systems, aviation systems, medical equipment, amusement machines, vehicles, safety equipment, and installations subject to separate industry or government regulations.
- Systems, machines, and equipment that could present a risk to life or property.

Please know and observe all prohibitions of use applicable to the products.

NEVER USE THE PRODUCTS FOR AN APPLICATION INVOLVING SERIOUS RISK TO LIFE OR PROPERTY WITHOUT ENSURING THAT THE SYSTEM AS A WHOLE HAS BEEN DESIGNED TO ADDRESS THE RISKS, AND THAT THE OMRON PRODUCT IS PROPERLY RATED AND INSTALLED FOR THE INTENDED USE WITHIN THE OVERALL EQUIPMENT OR SYSTEM.

## **PERFORMANCE DATA**

Performance data given in this document is provided as a guide for the user in determining suitability and does not constitute a warranty. It may represent the result of OMRON's test conditions, and the users must correlate it to actual application requirements. Actual performance is subject to the OMRON Warranty and Limitations of Liability.

## **CHANGE IN SPECIFICATIONS**

Product specifications and accessories may be changed at any time based on improvements and other reasons.

It is our practice to change model numbers when published ratings or features are changed, or when significant construction changes are made. However, some specifications of the product may be changed without any notice. When in doubt, special model numbers may be assigned to fix or establish key specifications for your application on your request. Please consult with your OMRON representative at any time to confirm actual specifications of purchased products.

## **DIMENSIONS AND WEIGHTS**

Dimensions and weights are nominal and are not to be used for manufacturing purposes, even when tolerances are shown.

## **ERRORS AND OMISSIONS**

The information in this document has been carefully checked and is believed to be accurate; however, no responsibility is assumed for clerical, typographical, or proofreading errors, or omissions.

## **PROGRAMMABLE PRODUCTS**

OMRON shall not be responsible for the user's programming of a programmable product, or any consequence thereof.

## **COPYRIGHT AND COPY PERMISSION**

This document shall not be copied for sales or promotions without permission.

This document is protected by copyright and is intended solely for use in conjunction with the product. Please notify us before copying or reproducing this document in any manner, for any other purpose. If copying or transmitting this document to another, please copy or transmit it in its entirety.

## Meanings of Signal Words

The following signal words are used in this manual.



Indicates a potentially hazardous situation which, if not avoided, will result in minor or moderate injury, or may result in serious injury or death. Additionally there may be significant property damage.

## Meanings of Alert Symbols

The following alert symbols are used in this manual

	Indicates general prohibitions for which there is no specific symbol.
	Indicates the possibility of laser radiation.
	Indicates the possibility of explosion under specific conditions.
	Indicates prohibition when there is a risk of minor injury from electrical shock or other source if the product is disassembled.



This product is not designed or rated for ensuring safety of persons.  
Do not use it for such purposes.



The Sensor emits visible light, which may adversely affect the eyes in rare instances.  
Do not look directly into the light emitted from the Sensor. When the subject is a specular reflective object, protect your eyes from reflected light.



A lithium ion battery is built into the Touch Finder and may occasionally combust, explode, or burn if not treated properly.  
Dispose of the Touch Finder as industrial waste, and never disassemble, apply pressure that would deform, heat to 100 °C or higher, or incinerate the Touch Finder.



High-voltage parts inside; danger of electrical shock. Do not open the product cover.



## Precautions for Safe Use

The following points are important to ensure safety, so make sure that they are strictly observed.

### 1. Installation Environment

- Do not use the product in environments where it can be exposed to inflammable/explosive gas.
- To secure the safety of operation and maintenance, do not install the product close to high-voltage devices and power devices.
- Install the product in such a way that its ventilation holes are not blocked.
- Tighten mounting screws at the torque specified in this manual.

### 2. Power Supply and Wiring

- The power supply voltage must be within the rated range (24 VDC  $\pm$ 10%), and an AC voltage must not be used.
- Reverse connection of the power supply is not allowed. Do not short the load of the open collector output.
- The load must be within the rated range.
- High-voltage lines and power lines must be wired separately from this product. Wiring them together or placing them in the same duct may cause induction, resulting in malfunction or damage.
- Use the products within the power supply voltages specified in this manual.
- Use the specified size of crimp terminals to wire connections. Do not connect wires that have been simply twisted together directly to the power supply or terminal block.
- Use a DC power supply with safety measures against high voltages (safety extra low-voltage circuit).
- Use independent power sources for the products. Do not use a shared power source.
- Tighten mounting screws at the torque specified in this manual.
- Always turn OFF the power supply before connecting or disconnecting cables or the power supply wiring.

### 3. Battery

- Do not short the positive and negative terminals of the Battery.
- Do not use the Touch Finder in an environment that exceeds the operating temperature range of the Battery. If the Touch Finder is used at temperatures that exceed the operating temperature range, the protective device may activate and prevent charging.
- Do not connect the Battery directly to a power supply or car cigarette lighter socket.
- Do not use the Touch Finder with any other type of battery.
- Turn OFF the power supply immediately if the Battery leaks or produces an odor. Electrolyte leaked from the Battery may ignite, possibly causing smoke, rupture, or fire.
- If during usage, charging, or storage, the Battery produces an odor, heats, becomes discolored, becomes misshapen, or exhibits any other unusual conditions, remove it and do not use it. Continuing to use such a Battery may result in the Battery heating, smoking, rupturing, or igniting.
- If the Touch Finder (FQ2-D31) will be installed permanently or semi-permanently, remove the Battery (FQ-BAT1). If the rated temperature is exceeded with the Battery inserted, the protective circuit may activate and stop the Touch Finder.

### 4. AC Adapter

- Use an AC cable that is suitable for the power supply and power voltage you are using.
- Do not touch the power plug with a wet hand. Doing so may result in electrical shock.
- If you notice an abnormal condition, such as smoke, abnormal heating of the outer surface, or a strange odor, immediately stop using the AC Adapter, turn OFF the power, and remove the power plug from the outlet.  
Consult your dealer, as it is dangerous to attempt to repair the AC Adapter yourself.
- If the AC Adapter is dropped or damaged, turn OFF the power, remove the power plug from the outlet, and contact your dealer. There is a risk of fire if you continue using the AC Adapter.

## 5. Handling

- Connector Cover

Always attach the connector cover when you disconnect the cable. If you do not attach the connector cover, foreign matter may enter the connection, causing malfunctions or damage.

- Lens Cap

Always attach a C-mount lens cap to the lens mount when you remove the lens. If dust or dirt adhere to the imaging elements, false detection or failure may occur.

- Sensor Waterproof Sheets

Do not remove or damage the waterproof sheets on the sides of the Sensor. Doing so may allow dust, dirt, or water drops to enter the Sensor and damage it.

## 6. Other

- Do not use this product in safety circuits associated with nuclear power and human life.
- Do not disassemble, repair, modify, deform by pressure, or incinerate this product.
- Dispose of this product as industrial waste.
- Connect the special products (Sensor, Touch Finder, Cables). The product might break down or malfunction if you use a part not included in the special products.
- If you notice an abnormal condition, such as a strange odor, extreme heating of any product, or smoke, immediately stop using the product, turn OFF the power, and consult your dealer.
- The Sensor surfaces become hot during use. Do not touch them.
- Do not drop or subject the products to shock.
- Use the special Sensor (FQ2-S), Touch Finder (FQ2-D), Sensor Data Unit (FQ-SDU), Cables (FQ-WN, FQ-WD, FQ-WU, and FQ-VP), Battery (FQ-BAT1), and AC Adapter (FQ-AC). Using other than the specified products may cause fire, burning, malfunction or failure.
- If the product has a lock mechanism, always make sure it is locked before using the product.

## 7. Laws and Regulations, Standards

- This product complies with the following EC Directives and EN Standards:  
EC Directive No.2004/104/EC  
EN Standards EN61326

## Precautions for Correct Use

Observe the following precautions to prevent failure to operate, malfunctions, or undesirable effects on product performance.

### 1. Installation Site

Do not install this product in locations subjected to the following conditions:

- Ambient temperature outside the rating
- Rapid temperature fluctuations (causing condensation)
- Relative humidity outside the range of 35 to 85%
- Direct vibration or shock
- Strong ambient light (such as other laser beams, light from arc-welding machines, or ultraviolet light)
- Direct sunlight or near heaters
- Strong magnetic or electric field

Also, do not install this product in locations subjected to the following conditions to ensure its protective performance as described in the specifications:

- Presence of corrosive or flammable gases
- Presence of dust, salt, or iron particles
- Water, oil, or chemical fumes or spray, or mist atmospheres

Installing and Using a Sensor with Built-in Lighting

- The front-panel plate may occasionally become fogged from the inside if the Sensor is used in location with high humidity and the temperature changes drastically.
- Do not install any objects except for the special mounting brackets within the dotted lines in the following figure. The front-panel plate may become fogged from the inside.

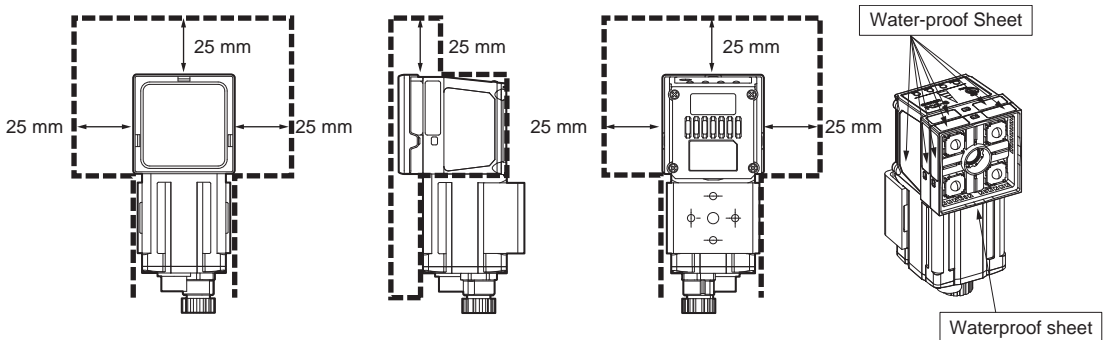

### 2. Power Supply, Connection, and Wiring

- When using a commercially available switching regulator, make sure that the FG terminal is grounded.
- If surge currents are present in the power lines, connect surge absorbers that suit the operating environment.
- Before turning ON the power after the product is connected, make sure that the power supply voltage is correct, there are no incorrect connections (e.g. load short-circuit) and the load current is appropriate. Incorrect wiring may result in breakdown of the product.
- Do not subject the Cables to twisting stress. Doing so may damage the Cables.
- Always turn OFF the power supply before connecting or disconnecting Cables. The Sensor may fail if a Cable is connected or disconnected while power is being supplied.
- For cables, use only the special products specified in this manual.

 p.487, p.488, p.489, p.490

- Use only combinations of the Sensor and Touch Finder specified in this manual. Using other combinations may cause malfunction or damage.

- Do not turn the power OFF in the following instances. Doing so will damage data that is in the process of being saved.
  - While data is being saved in internal memory
  - While data is being saved on the SD card
- The LCD panel has been made using precision technology, and sometimes a few pixels are missing in the panel. This is due to the structure of the LCD panel, and is not a malfunction.
- Influence of Temperature Changes on Optical Axis
 

Due to the characteristics of the materials that are used in the Sensor, changes in the ambient temperature may cause the center of the optical axis to change by several pixels.
- Imaging Elements
 

Due to the specifications of the CMOS image sensors that are used in the Vision Sensor, lines may appear in images for some measurement conditions or gain settings. These do not indicate defects or faults in the Vision Sensor. Also, there may be some pixel defects, but these do not indicate defects or faults in the Vision Sensor.

### 3. Battery

- Do not use or charge the Battery with other than the specified products.
- Do not charge the Battery with other than the specified AC adapter.
- When using the Touch Finder, the battery cover screw must be tightened.

### 4. AC Adapter

- During maintenance and when not using the Touch Finder for an extended time, remove the power plug from the outlet.
- Do not bend the power cable past its natural bending radius.
- Do not use the AC Adapter with other than the specified products.
- If a voltage higher than 380 V is applied, there is a risk that the capacitor will be damaged, the pressure valve will open, and vaporized gas will be emitted. If there is a possibility that a voltage higher than 380 V will be applied, use a protective device.

### 5. Maintenance and Inspection

Do not use thinner, benzene, acetone or kerosene to clean the Sensor and Touch Finder. If large dust particles adhere to the Camera, use a blower brush (used to clean camera lenses) to blow them off. Do not use breath from your mouth to blow the dust off. To remove dust particles from the Camera, wipe gently with a soft cloth (for cleaning lenses) moistened with a small amount of alcohol. Do not use excessive force to wipe off dust particles. Scratches to the Camera might cause error.

## Editor's Note

### ■ Meaning of Symbols

Menu items that are displayed on the Touch Finder LCD screen, and windows, dialog boxes and other GUI elements displayed on the PC are indicated enclosed by brackets "[ ]".

### ■ Visual Aids

#### Important

Indicates points that are important to achieve the full product performance, such as operational precautions.

#### Note

Indicates application procedures.



Indicates pages where related information can be found.

# Table of Contents

## 1. Introduction

1-1 FQ2-series Vision Sensors	20
1-2 Measurement Process	21
1-3 Startup Display and Display Elements	22
Startup Display	22
Display Elements	23
1-4 Basic Operational Flow	24

## 2. Installation and Connections

2-1 System Configuration	26
2-2 Part Names and Functions	29
2-3 Installation	33
FQ2-S□□□□□□□ (Sensors with Built-in Lighting)	33
FQ2-S3□-□□□ (Sensors with C-mounts)	34
Installation Precautions	38
Mounting to DIN Track	39
Mounting to a Control Panel	39
Using the Touch Finder as a Portable Device (with Battery)	40
Mounting to DIN Track	41
2-4 Wiring	42
I/O Signal Circuit Diagrams	43
Power Supply Specifications When a Switching Regulator Is Connected	43
Attaching the LED Warning Label	43
2-5 Setting Up Ethernet	53
Connecting to Sensors from the Touch Finder	53
Connecting to Sensors from External Devices Such as PLCs	54
Connecting to Sensors from a Computer Using the PC Tool	54

## 3. Taking Images

3-1 Selecting a Sensor for Configuration	58
3-2 Setting Conditions for Taking Images	59

<b>3-3 Adjusting Image Quality</b> .....	<b>60</b>
Adjusting the Focus .....	60
Adjusting Image Brightness with External Lighting .....	61
Adjusting the Brightness .....	61
Taking Clear Images of Moving Objects .....	63
Improving the Image Quality of Metallic and other Shiny Surfaces .....	64
Adjusting the Colors of the Image (White Balance) (Only for Sensors with Color Cameras) .....	65
<b>3-4 Adjusting the Timing of Taking Images</b> .....	<b>66</b>
Delaying the Image Capture Timing from the Trigger Input .....	66
Adjusting External Lighting Timing .....	67
Preventing Mutual Interference of Multiple Sensors .....	67
<b>3-5 Adjusting the Images That Were Taken</b> .....	<b>68</b>
Image Adjustment .....	68
Filtering the Images (Filter Items) .....	69
Compensating for Position Offset (Position Compensation Items) .....	74
Edge Rotation Position Compensation .....	85

## 4. Setting Up Inspections

<b>4-1 Inspection Item Selection Guide</b> .....	<b>90</b>
<b>4-2 Setup Procedure for Inspection Items</b> .....	<b>92</b>
<b>4-3 Configuring Inspection Items</b> .....	<b>93</b>
Adding New Inspection Items .....	93
Modifying Existing Inspection Items .....	94
Deleting Inspection Items .....	94
<b>4-4 Inspecting with the Search Inspection Item</b> .....	<b>95</b>
Search Inspection Item .....	95
Setup Procedure for the Search Inspection Item .....	95
Increasing Measurement Position Accuracy .....	97
Obtaining Multiple Results Simultaneously .....	97
Select the Results to Output .....	98
Reflect in Total Judgement .....	98
Unstable Search Results .....	99
Increasing Processing Speed .....	99
Editing the Model and Measurement Regions .....	100
Errors .....	104



<b>4-5 Inspecting with the Shape Search II Inspection Item . . . . .</b>	<b>105</b>
Shape Search II Inspection Item . . . . .	105
Setup Procedure for the Shape Search II Inspection Item . . . . .	105
Obtaining Multiple Results Simultaneously . . . . .	107
Select the Results to Output . . . . .	108
Reflect in Total Judgement . . . . .	108
Unstable Shape Search II Results . . . . .	109
Increasing Processing Speed . . . . .	110
Editing the Model Regions and Measurement Region . . . . .	110
Errors . . . . .	112
<b>4-6 Inspecting with the Sensitive Search Inspection Item . . . . .</b>	<b>113</b>
Sensitive Search Inspection Item . . . . .	113
Setup Procedure for the Sensitive Search Inspection Item . . . . .	113
Reflect in Total Judgement . . . . .	115
Increasing Measurement Position Accuracy . . . . .	115
Select the Results to Output . . . . .	115
Changing the Number Region Divisions . . . . .	116
Inspecting Plain Regions . . . . .	116
Unstable Search Results . . . . .	116
Increasing Processing Speed . . . . .	117
Editing the Model Regions and Measurement Region . . . . .	117
Errors . . . . .	119
<b>4-7 Inspecting with the Edge Position Inspection Item . . . . .</b>	<b>120</b>
Edge Position . . . . .	120
Setup Procedure for Edge Position . . . . .	120
Reflect in Total Judgement . . . . .	122
Changing Edge Detection Conditions (Sensors with Monochrome Cameras Only) . . . . .	122
Unstable Edge Position Results . . . . .	122
Increasing Processing Speed for Edge Position . . . . .	125
Measurement Data That Can Be Used for External Outputs and Calculations . . . . .	125
Measurement Data That Can Be Logged for Edge Position . . . . .	125
Errors . . . . .	126
<b>4-8 Inspecting with the Edge Width Inspection Item . . . . .</b>	<b>127</b>
Edge Width Inspection Item . . . . .	127
Setup Procedure for Edge Width Inspection Item . . . . .	127
Changing Edge Detection Conditions (Sensors with Monochrome Cameras Only) . . . . .	129
Reflect in Total Judgement . . . . .	129
Unstable Edge Width Results (Sensors with Color Cameras) . . . . .	129
Increasing Edge Width Processing Speed . . . . .	129
Measurement Data That Can Be Used for External Outputs and Calculations . . . . .	129
Measurement Data That Can Be Logged for Edge Width . . . . .	130
Errors . . . . .	130

<b>4-9 Inspecting with the Edge Pitch Inspection Item</b> . . . . .	<b>131</b>
Edge Pitch Inspection Item . . . . .	131
Setup Procedure for Edge Width Inspection Item . . . . .	131
Changing Edge Detection Conditions (Sensors with Monochrome Cameras Only) . . . . .	133
Reflect in Total Judgement . . . . .	133
Unstable Edge Pitch Results (Sensors with Color Cameras Only) . . . . .	133
Increasing Edge Pitch Processing Speed . . . . .	133
Measurement Data That Can Be Used for External Outputs and Calculations . . . . .	134
Measurement Data That Can Be Logged for Edge Pitch . . . . .	134
Errors . . . . .	134
<b>4-10 Inspecting with Color Data Inspection Item</b> . . . . .	<b>136</b>
Color Data Inspection Item . . . . .	136
Setup Procedure for Color Data Inspection Item . . . . .	136
Reflect in Total Judgement . . . . .	138
Measurement Data That Can Be Used for External Outputs and Calculations . . . . .	138
Measurement Data That Can Be Logged (Color Data) . . . . .	139
Increasing Processing Speed for Color Data . . . . .	139
<b>4-11 Inspecting with the Area Inspection Item</b> . . . . .	<b>140</b>
Area Inspection Item . . . . .	140
Setup Procedure for Area . . . . .	140
Reflect in Total Judgement . . . . .	142
Unstable Area Results . . . . .	142
Changing the Area Detection Conditions . . . . .	144
Increasing Processing Speed for Area . . . . .	144
Measurement Data That Can Be Used for External Outputs and Calculations . . . . .	145
Measurement Data That Can Be Logged for Area . . . . .	145
Errors . . . . .	145
<b>4-12 Inspecting with the Labeling Inspection Item</b> . . . . .	<b>146</b>
Labeling . . . . .	146
Setup Procedure for Labeling Inspection Item . . . . .	146
Unstable Labeling Results . . . . .	148
Changing the Label Detection Conditions . . . . .	150
Changing the Label Extraction Conditions . . . . .	151
Sorting Extracted Labels . . . . .	151
Reflect in Total Judgement . . . . .	152
Editing the Measurement Region . . . . .	152
Increasing the Processing Speed . . . . .	153
Measurement Data That Can Be Used for External Outputs and Calculations . . . . .	153
Measurement Data That Can Be Logged for Labeling . . . . .	154
Errors . . . . .	154

<b>4-13 Calculations and Judgements Using Inspection Item Data</b> .....	<b>155</b>
Calculation .....	155
Examples for Calculation .....	157
Procedure (Calculation) .....	157
Function List .....	159

## 5. Testing and Saving Settings

<b>5-1 Performing Test Measurements</b> .....	<b>170</b>
Performing Test Measurements with Samples .....	170
Performing Test Measurements with Saved Images (Re-measuring) .....	170
<b>5-2 Shortening the Measurement Takt Time</b> .....	<b>172</b>
Checking the Measurement Takt Time .....	172
Increasing Image Input Speed .....	173
Changing the Image Input Mode .....	174
<b>5-3 Adjusting the Judgement Parameters</b> .....	<b>175</b>
Adjusting Judgement Parameters While Looking at Measurement Results .....	175
Setting Up the Best Judgement Parameters Automatically .....	175
<b>5-4 Checking a List of All Inspection Item Results</b> .....	<b>177</b>
<b>5-5 Saving Data to the Sensor</b> .....	<b>178</b>

## 6. Operation

<b>6-1 Starting Operation</b> .....	<b>180</b>
Run Mode Display .....	180
Moving to Run Mode .....	180
<b>6-2 Configuring the Run Mode Display</b> .....	<b>182</b>
<b>6-3 Checking the Trend of Measurement Results with Graphs</b> .....	<b>184</b>
Trend Monitor .....	184
Histograms .....	185
<b>6-4 Adjusting Judgement Parameters during Operation</b> .....	<b>187</b>
Preparations .....	187
Changing the Judgement Parameters in Run Mode .....	187

## 7. Convenient Functions

<b>7-1 Changing the Scene to Change the Line Process</b> .....	<b>190</b>
What Are Scenes? .....	190
Creating New Scenes .....	191
Changing Scene Names, Copying Scenes, and Deleting Scenes .....	191
Switching Scenes from an External Device .....	191
Setting the Startup Scene .....	192

<b>7-2 Calibration</b> .....	<b>193</b>
Calibration .....	193
Setting the Calibration Pattern .....	194
Selecting the Calibration Pattern to Use .....	199
<b>7-3 Display Functions</b> .....	<b>200</b>
Image Zoom .....	200
Displaying a Live Image .....	200
Displaying a Frozen Image .....	200
Displaying a Saved Image .....	201
Updating the Display and Measurement Results Only for NG Measurement Results .....	201
Automatically Changing to the Display for Any Sensor with an NG Result ..	202
Hiding the Menu .....	202
Turning ON/OFF the Touch Finder Backlight .....	202
Changing the Brightness of the Touch Finder .....	202
<b>7-4 Monitoring the Signal I/O Status</b> .....	<b>203</b>
<b>7-5 Connecting to More Than One Sensor</b> .....	<b>204</b>
Setting the Sensors to Connect .....	204
Selecting the Display When More Than One Sensor Is Connected .....	206
<b>7-6 Logging Measurement Data and Image Data</b> .....	<b>208</b>
Logging Procedure .....	208
Logging All Data (File Logging) .....	209
Checking Recent Measurement Trends (Recent Results Logging) .....	214
<b>7-7 Saving Sensor Settings</b> .....	<b>218</b>
Backing Up Settings in External Memory .....	218
Restoring Data to the Sensor from External Memory .....	219
<b>7-8 SD Card Operations</b> .....	<b>220</b>
Inserting and Removing SD Cards .....	221
Checking the Available Space on the SD Card .....	222
Formatting an SD Card .....	222
<b>7-9 Convenient Functions for Operation</b> .....	<b>223</b>
Setting a Password to Prevent Unwanted Changes .....	223
Capturing the Displayed Image .....	224
Saving the Currently Displayed Camera Image .....	224
Setting the Startup Run Display Pattern .....	225
Specifying the Sensors to Connect Continuously .....	225
Monitoring and Setting Up a Sensor from Two Touch Finders .....	225
<b>7-10 Convenient Functions for Setup</b> .....	<b>227</b>
Making Settings with Stored Images .....	227

<b>7-11 Functions Related to the System</b> .....	<b>229</b>
Turning OFF the Integrated Sensor Lighting (Only Sensors with Built-in Lighting) .....	229
Switching the Display Language .....	229
Setting the Time on the Touch Finder .....	229
Initializing the Sensor and Touch Finder .....	229
Restarting the Sensor and Touch Finder .....	229
Checking Versions .....	230
Checking the Touch Finder Battery Level .....	230
Changing the Sensor Name .....	230
Checking Available Memory in the Sensor .....	230
Correcting the Touch Screen Positions of the Touch Finder .....	230
Setting the Resolution of Measurement Objects Displayed on the PC Tool .....	230
Rotating the Touch Finder Image by 180° .....	230
Changing the Sensor's BUSY Indicator .....	231

## 8. Controlling Operation and Outputting Data with a Parallel Connection

<b>8-1 Controlling Operation and Outputting Data with the Sensor's Standard Parallel Connection</b> .....	<b>234</b>
Basic Operation with a Parallel Connection .....	234
Setting the Measurement Trigger .....	235
Setting the Outputs .....	240
Controlling the Sensor from an External Device .....	246
<b>8-2 Controlling Operation and Outputting Data with a Parallel Interface Sensor Data Unit</b> .....	<b>256</b>
Overview .....	256
Setting the Measurement Trigger .....	256
Setting Output Data .....	257
Aligning the Data Output Timing with the External Device .....	262
Changing the Settings of the I/O Signals .....	270
Controlling Operation from an External Device .....	271

## 9. Connecting through Ethernet

<b>9-1 Introduction</b> .....	<b>282</b>
-------------------------------	------------

<b>9-2</b>	<b>Outputting Data and Controlling Operation through EtherNet/IP . . . .</b>	<b>283</b>
	Introduction to EtherNet/IP . . . . .	283
	FQ2 Communications for EtherNet/IP Connections . . . . .	285
	Setting Up EtherNet/IP Communications . . . . .	289
	Tag Data Link Setting Methods . . . . .	292
	Setting the Data To Output Automatically after Measurements . . . . .	295
	Memory Assignments and Commands . . . . .	300
	Timing Chart for EtherNet/IP Communications . . . . .	318
	Sample Ladder Programming . . . . .	323
<b>9-3</b>	<b>PLC Link Connections . . . . .</b>	<b>324</b>
	Setting Up PLC Link Communications . . . . .	327
	Setting the Data To Output Automatically after Measurements . . . . .	329
	Memory Assignments for PLC Link Communications . . . . .	334
	Timing Chart For PLC Link Communications . . . . .	347
	Sample Ladder Programming . . . . .	349
<b>9-4</b>	<b>Controlling Operation and Outputting Data with TCP No-protocol Communications . . . . .</b>	<b>350</b>
	Setting Up No-protocol Communications . . . . .	351
	Setting the Data To Output Automatically after Measurements . . . . .	352
	Controlling the Sensor from an External Device (Procedure for No-protocol Command/Response Communications) . . . . .	357
<b>9-5</b>	<b>Controlling Operation and Outputting Data with FINS/TCP No-protocol Commands . . . . .</b>	<b>376</b>
	Introduction to FINS Commands . . . . .	376
	Setting Up Communications (FINS/TCP) . . . . .	377
	List of FINS Commands . . . . .	378
	FINS Command Details . . . . .	379

## 10. Connecting with RS-232C

<b>10-1</b>	<b>Introduction to RS-232C Connections . . . . .</b>	<b>392</b>
<b>10-2</b>	<b>Controlling Operation and Outputting Data with RS-232C No-protocol Communications . . . . .</b>	<b>393</b>
	Setting Up No-protocol Communications . . . . .	394
	Setting the Data To Output Automatically after Measurements . . . . .	395
	Controlling the Sensor from an External Device (Procedure for No-protocol Command/Response Communications) . . . . .	395

## 11. Troubleshooting

<b>11-1</b>	<b>Error Histories . . . . .</b>	<b>398</b>
<b>11-2</b>	<b>Error Messages . . . . .</b>	<b>400</b>
<b>11-3</b>	<b>Basic Troubleshooting . . . . .</b>	<b>401</b>

# 12. Appendices

<b>12-1 Menu Tables</b> .....	<b>404</b>
Image Tab Page .....	404
Inspect Tab Page .....	407
In/Out Tab Page .....	414
Test Tab Page .....	419
Run Tab Page (from Setup Display) .....	420
Tool .....	420
Common Menu Commands .....	429
<b>12-2 External Reference Parameters</b> .....	<b>430</b>
Color Gray Filter .....	430
Weak Smoothing .....	431
Strong Smoothing .....	431
Dilate .....	431
Erosion, Median, Extract Edges, Extract Horizontal Edges, Extract .....	432
Background Suppression .....	432
Shape Search II Position Compensation .....	434
Search Position Compensation .....	436
Edge Position Compensation .....	438
Two-edge Position Compensation .....	441
Two-edge Midpoint Compensation .....	444
Edge Rotation Position Compensation .....	448
Search .....	451
Sensitive Search .....	454
Shape Search II .....	457
Edge Position .....	460
Edge Width .....	461
Edge Pitch .....	462
Area .....	464
Color Data .....	466
Labeling .....	468
<b>12-3 Specifications and Dimensions</b> .....	<b>472</b>
Sensor .....	472
Touch Finder .....	479
Sensor Data Units .....	483
System Requirements for PC Tool for FQ .....	486
Options .....	486
<b>12-4 Updating the Software</b> .....	<b>491</b>
<b>12-5 Connecting a Previous Touch Finder (FQ-D30/D31)     to the FQ2-S Sensor</b> .....	<b>492</b>
<b>12-6 LED Safety</b> .....	<b>497</b>
Warning Label .....	497

<b>12-7 Requirements from Regulations and Standards</b> .....	<b>498</b>
Summary of Requirements to Manufactures .....	498
Summary of Requirements to User .....	500
Definitions of Laser Classification .....	501
<b>12-8 Detailed EtherNet/IP Communications Specifications</b> .....	<b>502</b>
<b>Index</b> .....	<b>506</b>
<b>Revision History</b> .....	<b>512</b>



# Introduction

---

<b>1-1 FQ2-series Vision Sensors</b> .....	<b>20</b>
<b>1-2 Measurement Process</b> .....	<b>21</b>
<b>1-3 Startup Display and Display Elements</b> .....	<b>22</b>
<b>1-4 Basic Operational Flow</b> .....	<b>24</b>

# 1-1 FQ2-series Vision Sensors

The FQ2 Series features Vision Sensors with integrated cameras and controllers. They can be used to easily achieve simple inspections and measurements.

You can use parallel controls, no-protocol communications on Ethernet, PLC Link communications on Ethernet, and EtherNet/IP communications on Ethernet as standard features. You can also use a Data Unit to enable control with full-scale parallel communications or RS-232C communications.

To set up and monitor the Vision Sensor, you can use either the Touch Finder or the PC Tool running on a computer. For actual operation, you can use the Vision Sensor on a stand-alone basis.

Setup, Image Confirmation, and Logging Tools

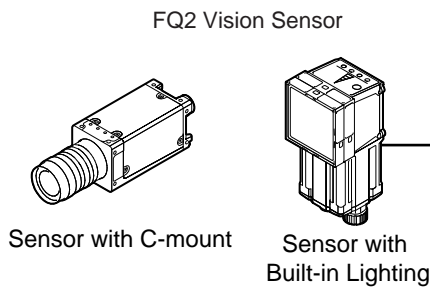

After the Sensor has been set up, it can be operated alone to perform measurements without the Touch Finder or PC Tool.

Touch Finder



Used to check images and set the judgement parameters. It can also be used to save measurement results and check status during operation.

PC Tool



The same functions as those that are provided by the Touch Finder can be performed from a computer. The PC Tool is available free of charge.

FQ2-series Vision Sensors are available in two different models. There are also Sensors with C-mounts that allow you to change the lens, and Sensors with Built-in Lighting. The differences are given in the following table.

Models	Single-function models	Standard models	High-resolution models	
Type	Sensors with Built-in Lighting			Sensors with C-mounts
Model number	FQ2-S1□□□□□□	FQ2-S2□□□□□□	FQ2-S3□□□□□□-08□	FQ2-S3□-13□
Number of simultaneous measurements	1	32		
Number of registered scenes	8	32		
Partial input	Horizontally only		Horizontally and vertically	
Lens mount	---			C-mount
Image processing method	Real color		Real color or monochrome (Model numbers for Monochrome Sensors end in "M.")	
Connection to Sensor Data Unit	Not possible.		Possible.	
Processing resolution	752×480		928×828	1280×1024

# 1-2 Measurement Process

This section describes the basic flow of the measurement process.

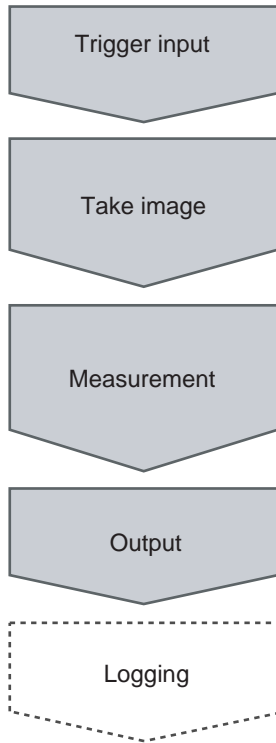

- The measurement is started by inputting a trigger signal from an external device.
- Images are taken according to the trigger.
- The image is measured to see if it matches the configured settings.
- You can also perform calculations based on the measurement results from inspection items.
- The overall judgement of all inspection items are output using OR logic.
- You can output detailed measurement result from the inspection items.
- Measurement data and image data can be logged in memory in the Sensor or in an SD card.

# 1-3 Startup Display and Display Elements

## Startup Display

- 1 The Sensor is automatically detected by the Touch Finder when power supply to the Sensor and Touch Finder is turned ON.**

The Auto Connect Display will appear if the Sensor cannot be detected. Check that cables are connected correctly to the Sensor and Touch Finder, and then press [Auto connect].



### Note

If the Sensor is still not detected after pressing [Auto Connect], refer to the following information.

 The Sensor cannot be detected: p. 401

- 2 When the Sensor is detected, the following display will appear.**

- The Setup Mode will appear if a Sensor that has not been set up is connected.

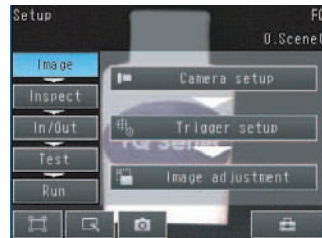

- The Run Mode will appear if a Sensor that has been set up is connected.



### Note

When the Touch Finder is started, IP addresses are automatically set for each Sensor. To allocate specific IP addresses, set the IP address of each Sensor and the Touch Finder.

 Setting Up Ethernet: p. 53

## Display Elements

This Sensor has a Setup Mode and a Run Mode.  
Refer to the following information for menu items.

 p. 404

### Setup Mode

In Setup Mode, you can set the image conditions, judgement parameters, and I/O settings for the Sensor.

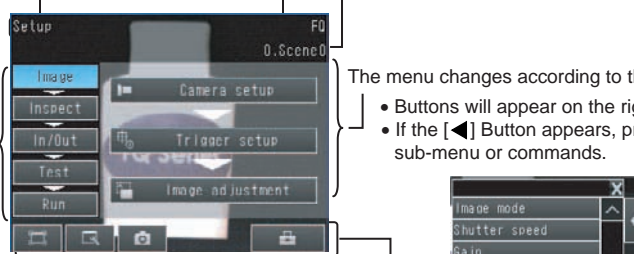

The name of the mode or the menu hierarchy is displayed.

The name of the Sensor being set up is displayed.

The selected scene number is displayed.







The menu changes according to the selected tab page.

- Buttons will appear on the right according to the mode.
- If the [] Button appears, pressing it will display the sub-menu or commands.

The setup flow is shown by these five tabs.

[Image]: Used to adjust the image.  
 [Inspect]: Used to set the inspection items.  
 [In/Out]: Used to set the I/O.  
 [Test]: Used to test and adjust the set measurements.  
 [Run]: Used to switch to Run Mode.

This button menu is always displayed.

-  **Only-image Button:** Used to select either displaying the camera image and messages, or only the camera image.
-  **Display Button:** Used to select the source of the image or to zoom the image.  
 Display Functions: p. 200
-  **Capture Button:** Used to capture the current screen to the SD card.  
 p. 224
-  **Tool Button:** Used to call functions, such as saving data or select scenes.

#### Note

The Display Button can be used to switch between the following images.

- Camera: The image taken by the camera is displayed.
  - Live: The live image is displayed.
  - Freeze: The image that was taken last is displayed.
- Log: A log image saved in internal memory is displayed.
- Logging image file: A log image saved in external memory is displayed.
- Camera image file: An image that was saved in external memory with  (Log Image Button) is displayed.

### Run Mode

In Run Mode, measurements are performed, and measurement results are output.

 p. 179

# 1-4 Basic Operational Flow

The following flow shows the basic operation of FQ2-series Vision Sensors.

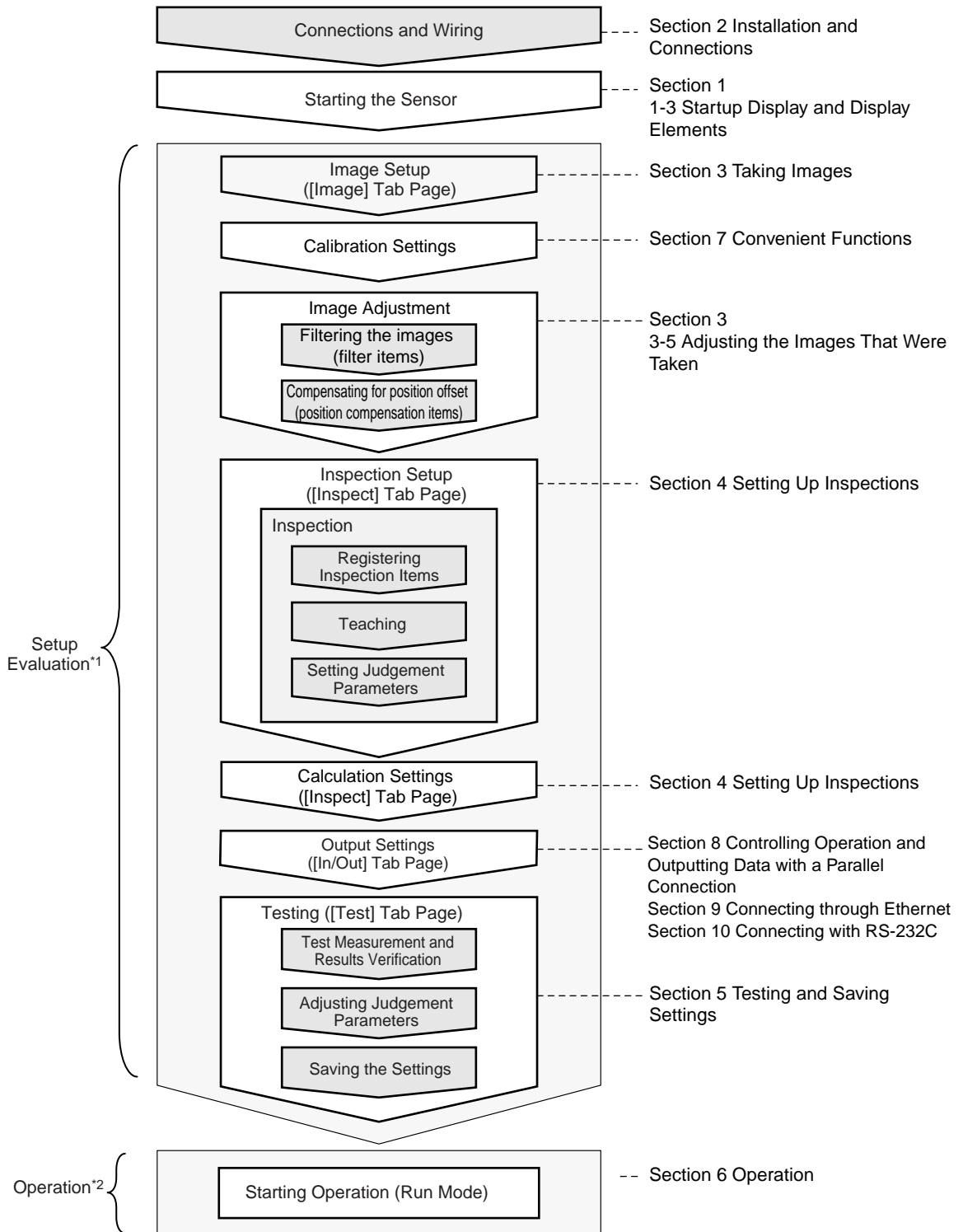

\*1: In Setup Mode, the Sensor can be set up and adjusted, but it does not output signals on the I/O lines.

\*2: In Run Mode, the Sensor performs measurements and outputs signals on the I/O lines.

# Installation and Connections

---

<b>2-1 System Configuration</b> .....	<b>26</b>
<b>2-2 Part Names and Functions</b> .....	<b>29</b>
<b>2-3 Installation</b> .....	<b>33</b>
<b>2-4 Wiring</b> .....	<b>42</b>
<b>2-5 Setting Up Ethernet</b> .....	<b>53</b>

# 2-1 System Configuration

## Ethernet (EtherNet/IP, No-protocol, or PLC Link) Connection

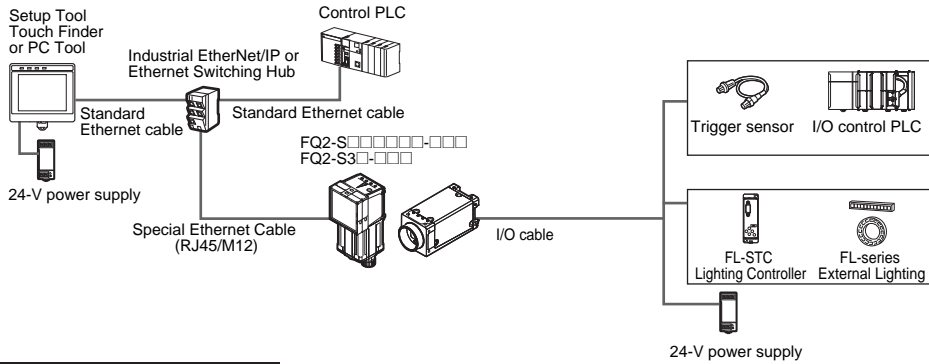

## Parallel Interface Connection

### Connection through a Parallel Interface Sensor Data Unit

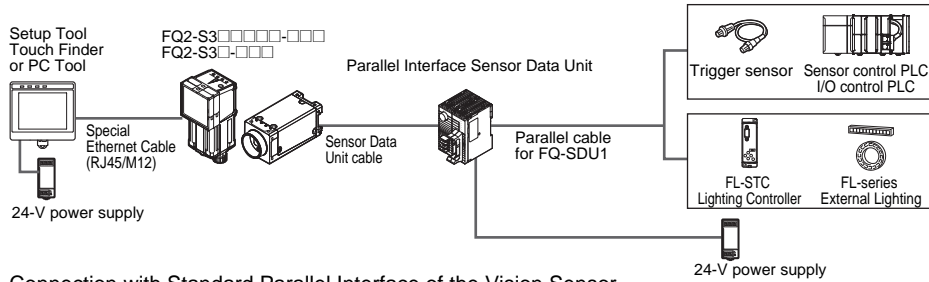

### Connection with Standard Parallel Interface of the Vision Sensor

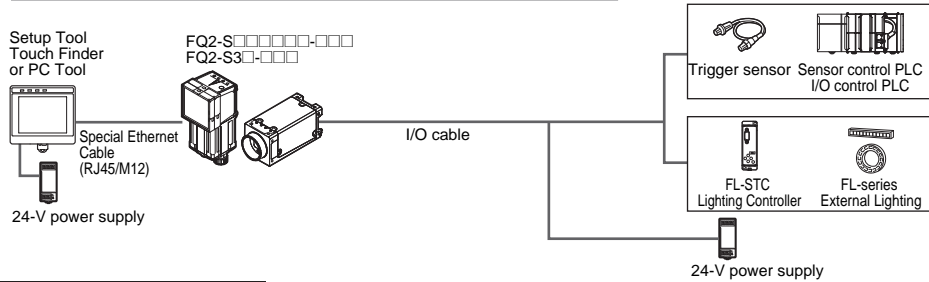

## RS-232C Serial Connection

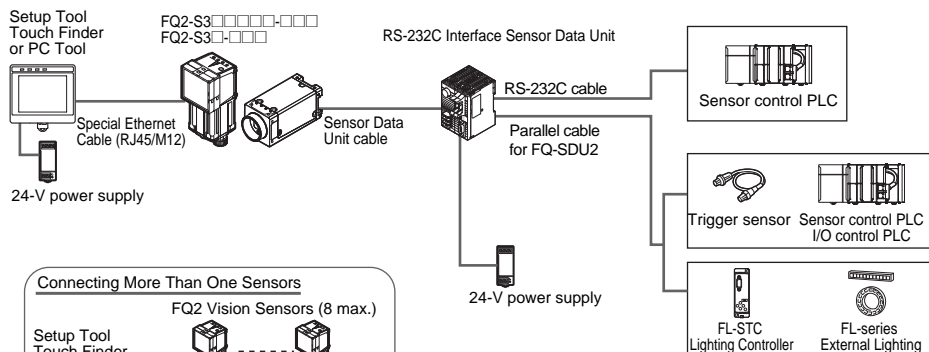

### Connecting More Than One Sensors

FQ2 Vision Sensors (8 max.)

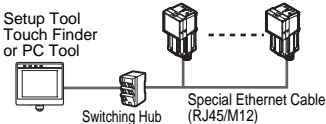

The Setup Tool can detect up to 32 Sensors and  
it can connect to up to eight Sensors at the same time.



Product	Model number	Remarks
FQ Vision Sensor	FQ2-S□□□□□□□-□□□ FQ2-S3□-□□□	This is the Vision Sensor.
Touch Finder	FQ2-D□□	This is a setup console.
PC Tool	---	The PC Tool can be used instead of the Touch Finder. If you register as a member, you can download the free PC Tool as a special service to purchasers. Refer to the <i>Member Registration Sheet</i> that is enclosed with the Sensor for the member registration procedure and the download procedure for special member software.
Parallel Interface Sensor Data Unit	FQ-SDU1□	You can connect a Sensor Data Unit to the I/O cable connector on the Vision Sensor and connect the Parallel Interface Sensor Data Unit to an external device. This allows you to output the results of judgement conditions, measurements from inspection items, and the results of expressions with parallel communications.
RS-232C Interface Sensor Data Unit	FQ-SDU2□	You can connect a Sensor Data Unit to the I/O cable connector on the Vision Sensor and connect the RS-232C Interface Sensor Data Unit to an external device. This allows you to use no-protocol communications to send and receive commands, inspection item parameters, and other data between the Sensor and the external control device that is connected with the RS-232C cable. You can also use the ACK signal (parallel command normal completion signal) for a parallel output from the Sensor Data Unit.
FQ Ethernet Cable	FQ-WN0□□	Connects the Sensors to external devices such as the Touch Finder, computers, and PLCs.
Standard RJ45 Ethernet Cable <sup>*1</sup>	---	Connects the Switching Hub to the Touch Finder, computers, and PLCs. Use a connector that complies with the FCC RJ45 standard. (STP (shielded twisted-pair) cable, category 5e or 6, impedance: 100 Ω)
I/O Cable	FQ-WD0□□	Connects the Sensor to the power supply and external devices.
Switching Hub	W4S1-0□□	Used to connect multiple Sensors to one Touch Finder or PC Tool.
Sensor Data Unit cable	FQ-WU0□□	This cable connects the FQ2-S3 Sensor to the Sensor Data Unit.
Parallel cable for FQ-SDU1	FQ-VP1□□□	This cable connects the Parallel Interface Sensor Data Unit to an external device.
Parallel cable for FQ-SDU2	FQ-VP2□□□	This cable connects the RS-232C Interface Sensor Data Unit to an external device.
RS-232C cable (to connect to a PLC)	Recommended: XW2Z-200S-V (2 m) or XW2Z-500S-V (5 m)	This cable connects the RS-232C Interface Sensor Data Unit to an external device.

\*1: The shape and dimensions of the Ethernet connector plug and jack are specified in ISO/IEC8877:1992 (JIS X 5110:1996) and RJ-45 of the FCC regulations. To prevent connector connection failures, the structure of the jack of this product does not allow insertion of plugs that do not comply with the standard. If a commercially available plug cannot be inserted, it is likely that the plug is non-compliant.

### Important

Do not connect network devices other than PLCs on the same network as the Touch Finder or computer. If another device is connected, the responsiveness of displays and settings of the Touch Finder or computer may become slow.

## Connection Compatibility

Yes: Supported, No: Not supported

Type of connection to FQ2-S		Other connection						
		EtherNet/IP	PLC Link on Ethernet	TCP no-protocol communications on Ethernet	FINS/TCP no-protocol communications on Ethernet	RS-232C <sup>*1</sup>	Parallel communications	
							Sensor's standard parallel communications	Parallel Interface <sup>*2</sup>
EtherNet/IP		---	No	Yes	Yes	Yes	Yes	
PLC Link on Ethernet		No	---	Yes	Yes	Yes	Yes	
TCP no-protocol communications on Ethernet		Yes	Yes	---	No	No	Yes	
FINS/TCP no-protocol communications on Ethernet		Yes	Yes	No	---	No	Yes	
RS-232C <sup>*1</sup>		Yes	Yes	No	No	---	Yes	
Parallel communications	Sensor's standard parallel communications	Yes	Yes	Yes	Yes	No	---	No
	Parallel Interface <sup>*2</sup>	Yes	Yes	Yes	Yes	No	No	---

\*1: This applies when an RS-232C Interface Sensor Data Unit is connected.

\*2: This applies when a Parallel Interface Sensor Data Unit is connected.

### Note

#### Connections Across Network Routers

You can connect to a Sensor on a different network than the Touch Finder or PC Tool through a router.

- To connect to a Sensor, directly specify the IP address of the Sensor. Automatic connection to a Sensor is not possible.
- Use a fixed IP address for the Sensor to connect to.

# 2-2 Part Names and Functions

## FQ2-S□□□□□□-□□□ (Sensors with Built-in Lighting)

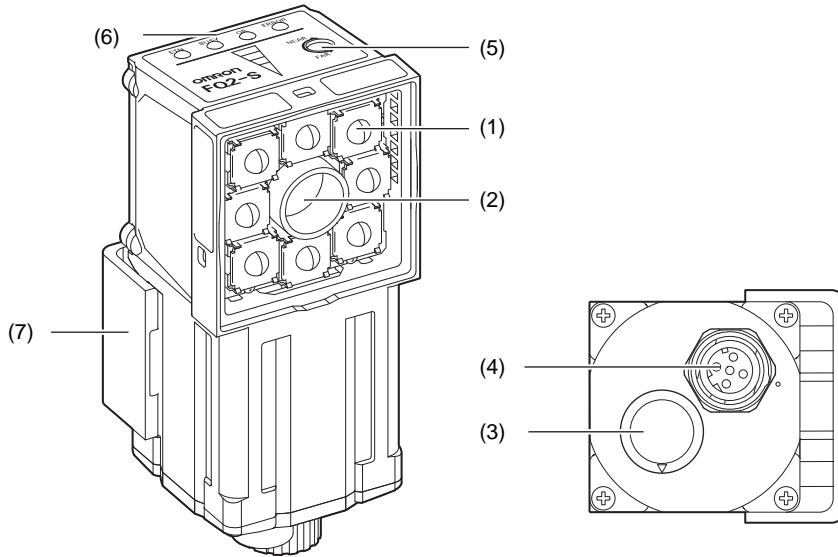

No.	Name	Description	
(1)	Lighting	LEDs for illumination	
(2)	Camera lens	This lens can be focused.	
(3)	I/O Cable connector	An FQ-WD or FQ-WU I/O Cable is used to connect the Sensor to the power supply and external I/O.	
(4)	Ethernet cable connector	An FQ-WN Ethernet Cable is used to connect the Sensor to external devices such as PLCs, the Touch Finder, or computers.	
(5)	Focus adjustment screw	Used to adjust the focus of the image.	
(6)	Operation indicators	OR	Lights orange when the overall judgement output (OR) signal turns ON.
		ETN	Lights orange during Ethernet communications.
		ERROR	Lights red when an error occurs. 11-1 Error Histories p. 398
		BUSY	Lights green when the Sensor is executing a process. * You can change the BUSY indicator to a RUN indicator. This indicator is set by default to a BUSY indicator, but if you change it to a RUN indicator, it will light green during operation. Changing the Sensor's BUSY Indicator: p. 231
(7)	Mounting Bracket	Used to mount the Sensor. The Mounting Bracket can be attached to the front, left side, right side, or back of the Sensor.	

# FQ2-S3□-□□□ (Sensors with C-mounts)

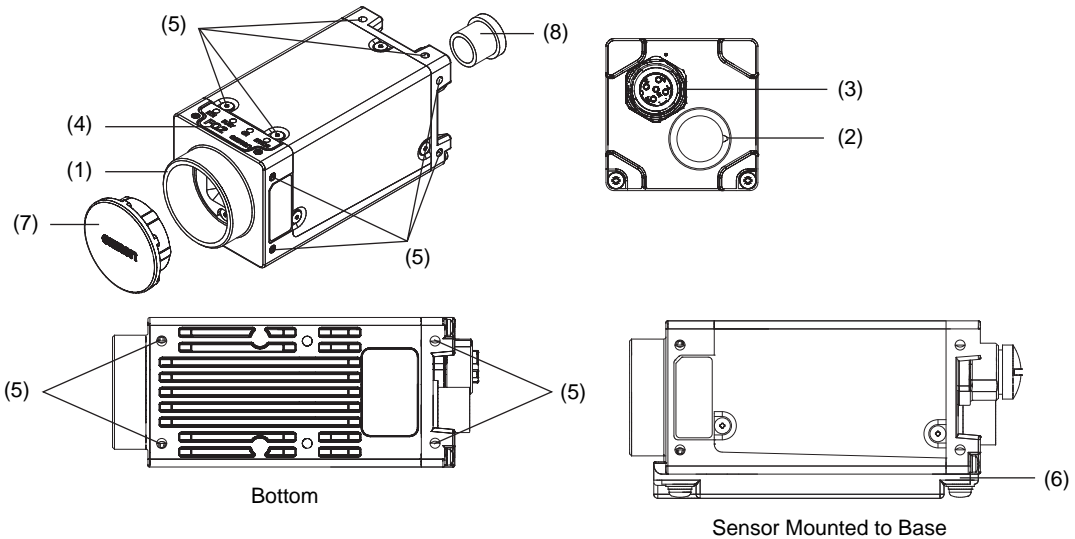

No.	Name	Description	
(1)	C-mount lens mounting surface	The C-mount lens and macro ring are attached here. Determine the appropriate CCTV lens (C-mount lens) to use based on the field of view required for the size of the measurement object. Optical Diagrams: p. 35	
(2)	I/O Cable connector	An FQ-WD or FQ-WU I/O Cable is used to connect the Sensor to the power supply, external I/O, and Data Unit.	
(3)	Ethernet Cable connector	An FQ-WN Ethernet Cable is used to connect the Sensor to external devices such as the Touch Finder or computers.	
(4)	Operation indicators	OR	Lights orange when the overall judgement output (OR) signal turns ON.
		ETN	Lights orange during Ethernet communications.
		ERROR	Lights red when an error occurs. 11-1 Error Histories p. 398
		BUSY	Lights green when the Sensor is executing a process. * You can change the BUSY indicator to a RUN indicator. This indicator is set by default to a BUSY indicator, but if you change it to a RUN indicator, it will light green during operation. Changing the Sensor's BUSY Indicator: p. 231
(5)	Mounting holes	These mounting holes for M3 screws are used to mount the Camera and to mount to the base. There are mounting holes on the top, bottom, left, and right surfaces. Dimensions: p. 477	
(6)	Mounting base (enclosed)	The mounting base has 1/4-20UNC threads and is used to mount the Sensor. The base can be attached to the bottom, top, left, or right side of the Sensor. * We recommend mounting the Sensor with the mounting screw holes. The mounting base does not necessarily need to be used.	
(7)	C-mount cover	This cover is attached to the C-mount lens fitting when a lens is not attached.	
(8)	Connector cover	This cover is attached to the connection when an Ethernet Cable is not connected.	

# Touch Finder

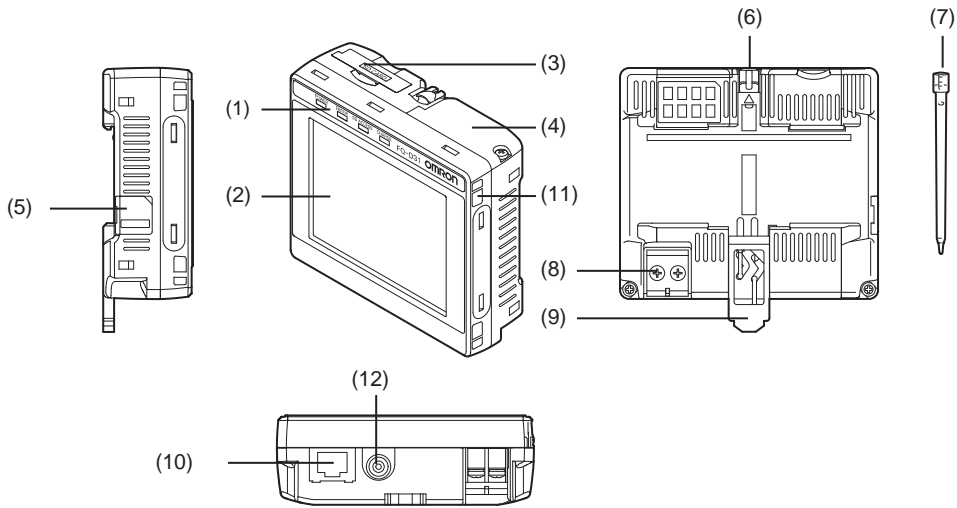

No.	Name	Description
(1)	Operation indicators	POWER Lights green when the Touch Finder is turned ON.
		ERROR Lights red when an error occurs. 11-1 Error Histories p. 398
		SD ACCESS Lights yellow when an SD card is inserted. Flashes yellow when the SD card is being accessed.
		CHARGE* <sup>1</sup> Lights orange when the Battery is charging.
(2)	LCD/touch panel	Displays the setting menu, measurement results, and images input by the camera.
(3)	SD card slot	An SD card can be inserted.
(4)	Battery cover* <sup>1</sup>	The Battery is inserted behind this cover. Remove the cover when mounting or removing the Battery.
(5)	Power supply switch	Used to turn the Touch Finder ON and OFF.
(6)	Touch pen holder	The touch pen can be stored here when it is not being used.
(7)	Touch pen	Used to operate the touch panel.
(8)	DC power supply connector	Used to connect a DC power supply. p. 50
(9)	Slider	Used to mount the Touch Finder to a DIN Track.
(10)	Ethernet port	Used when connecting the Touch Finder to the Sensor with an Ethernet cable. Insert the connector until it locks in place.
(11)	Strap holder	This is a holder for attaching the strap.
(12)	AC power supply connector* <sup>1</sup>	Used to connect the AC adapter.

\*1: Applicable to the FQ2-D31 only.

# Sensor Data Units

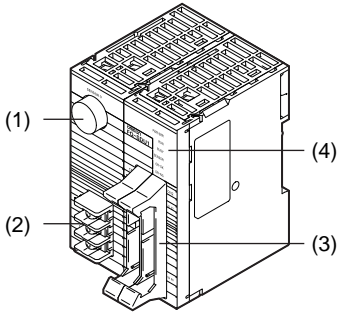

Front Surface of Parallel Interface Sensor Data Unit

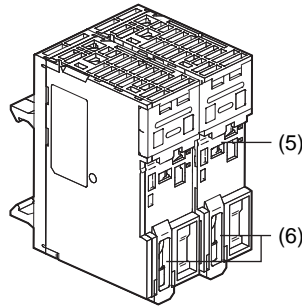

Back Surface of Parallel Interface Sensor Data Unit

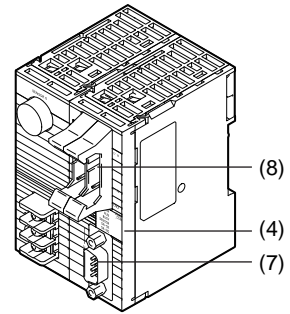

RS-232C Interface Sensor Data Unit

No.	Name	Description	
(1)	Sensor connector	Connects to the FQ2-S3.	
(2)	Power supply and ground terminal block	Connects to the 24-V power source and the ground line.	
(3)	Parallel I/O connector	Connects to the I/O connector.	
(4)	I/O indicators	POWER/ ERROR	Lights green when power is being supplied. Lights red when an error occurs.
		RUN	Lights green during operation.
		BUSY	Lights yellow when the Sensor is executing a process.
		SENSOR	Lights yellow when the Sensor is connected.
		OR-OK	Lights green when the overall judgement result is OK.
		OR-NG	Lights red when the overall judgement result is OFF or an error occurs.
		232C_COM	Lights yellow during RS-232C communications. (Provided only on the FQ-SDU2□.)
(5)	DIN Track mounting section	Mounts the Data Unit to a DIN Track.	
(6)	Slider	Used to secure the Data Unit to a DIN Track.	
(7)	RS-232C connector	Connects to the RS-232C connector.	
(8)	Parallel I/O connector	Connects to the I/O connector.	

# 2-3 Installation

## Installing the Sensor

### FQ2-S□□□□□□ (Sensors with Built-in Lighting)

#### Installation Procedure

- 1** Align the tabs on one side of the Mounting Bracket with the slot on the Sensor.  
The FQ-XL Mounting Bracket can be attached to the back, side, or front of the Sensor.
- 2** Press the Mounting Bracket onto the Sensor until the other tabs click into place.
- 3** Use the following optical charts to check the field of view and installation distance of the Sensor so that it is mounted at the correct position.  
Tightening torque (M4): 1.2 N·m

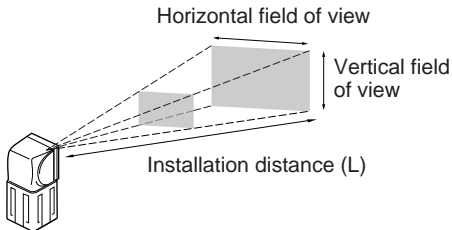
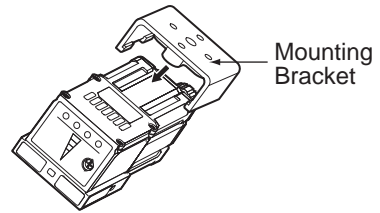

The optical chart indicates the horizontal field of view. The vertical field of view depends on the model as follows:  
 FQ2-S□□□□□□:  
 Approx. 60% of the horizontal field of view  
 FQ2-S□□□□□□-08□:  
 Approx. 90% of the horizontal field of view

**Note:** The tolerance is ±10%.

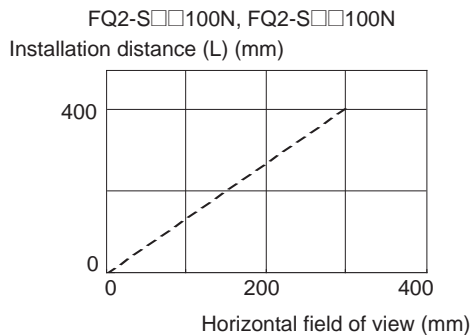
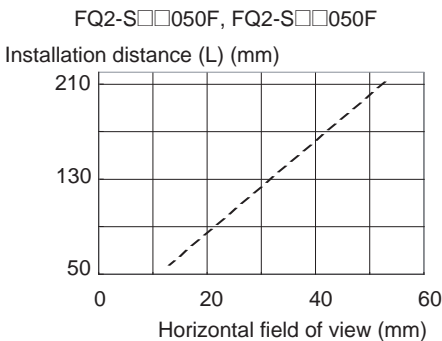
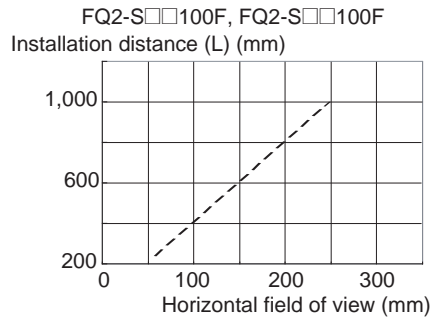
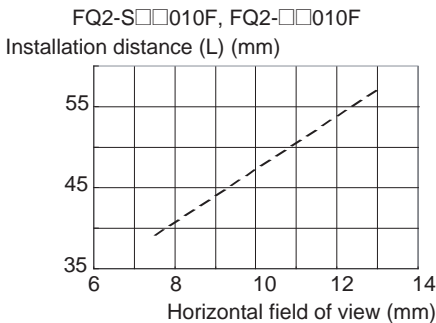

## Important

- There is a certain amount of deviation among Sensors in the center of the optical axis. For this reason, when installing the Sensor, check the center of the image and the field of view on the LCD monitor of the Touch Finder and in the PC Tool.

## Removal Procedure

- 1** Insert a flat-blade screwdriver between the Mounting Bracket and the Sensor case on either side and remove the Mounting Bracket.

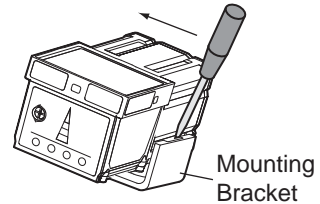

## FQ2-S3□-□□□ (Sensors with C-mounts)

## Installation Procedure

### Directly Mounting the Sensor

- 1** Mount the Sensor with M3 screws.  
Tightening torque: 0.54 N·m  
Effective depth of mounting holes: 4 mm

### Important

Refer to the dimension drawings in the appendix for the positions of the screw holes.

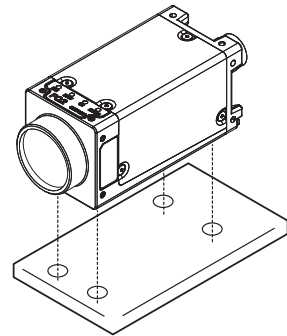

### Mounting the Sensor to the Base

- 1** You can attach the mounting base to the bottom, top, left, or right surface.  
(Recommended mounting screw tightening torque: 0.54 N·m)  
Tightening torque: 0.54 N·m  
Effective depth of mounting holes: 4 mm
- 2** Mount the Sensor with M3 screws.  
Tightening torque: 0.54 N·m  
Effective depth of mounting holes: 4 mm

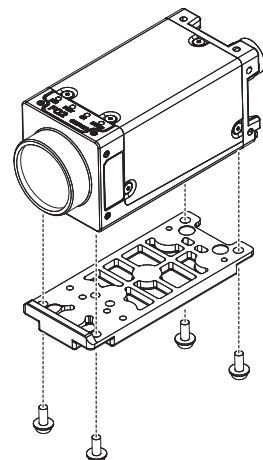



## Lens Selection

Use the following optical diagrams to determine the Lens, camera installation distance, and detection range.

### Optical Diagrams

The following values are estimates only. Adjustment is required after installing the camera.

#### 3Z4S-LE SV-□□□□H High-resolution, Low-distortion Lenses

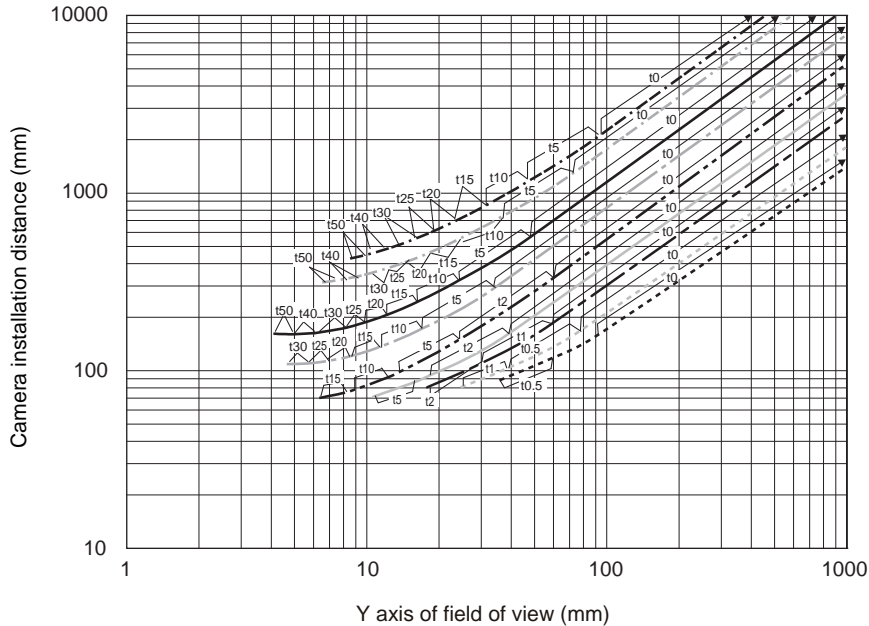

3Z4S-LE

SV-0614H
SV-0814H
SV-1214H
SV-1614H
SV-2514H
SV-3514H
SV-5014H
SV-7525H
SV-10028H

t: Macro ring

Examples

t0: Macro ring is not required.

t5: A 5-mm macro ring is required.

#### 3Z4S-LE SV-□□□□V-series Lenses

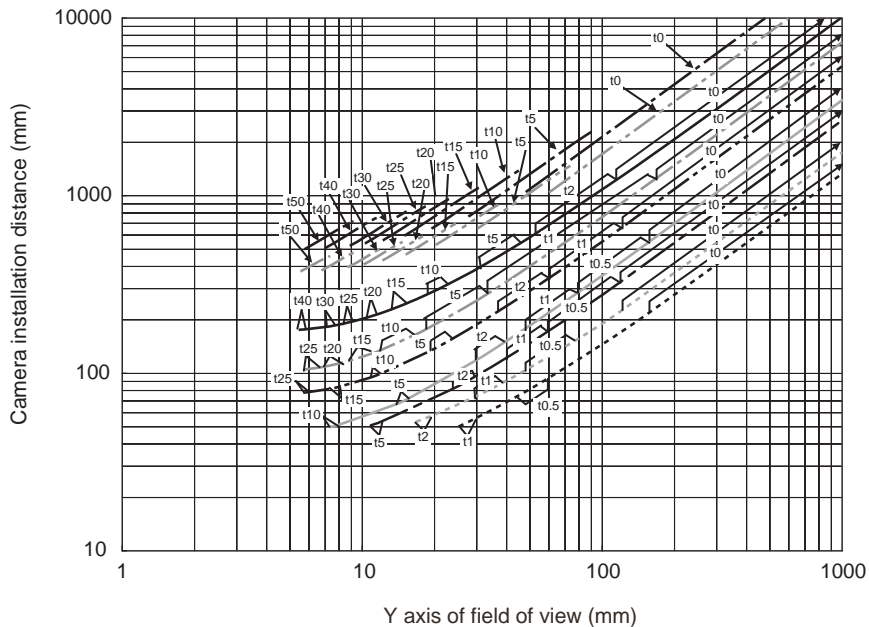

3Z4S-LE

SV-0614V
SV-0813V
SV-1214V
SV-1614V
SV-2514V
SV-3518V
SV-5018V
SV-7527V
SV-10035V

t: Macro ring

Examples

t0: Macro ring is not required.

t5: A 5-mm macro ring is required.

The X axis in the above optical diagrams represent field of view (mm)<sup>\*1</sup>. The Y axis represents the camera installation distance (mm) or WD (mm). These optical diagrams show the relationship between the detection range and installation distance for different CCTV Lenses. The values vary for each Lens. Pay close attention to the Lens that you are using when you refer to these optical diagrams. The macro ring thickness to be used is given as, for example "t5.0," on the graphs. "t0" means that a macro ring is not required. "t5.0" means that you must use a 5-mm macro ring.

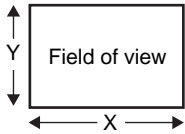

\*1: The Y axis in the optical charts represents the height of the field of view.

Example: If you use an 3Z4S-LE SV-2514H Lens for a measurement object that requires field of view of 35 mm, the camera installation distance must be 200 mm and a 2-mm macro ring is required.

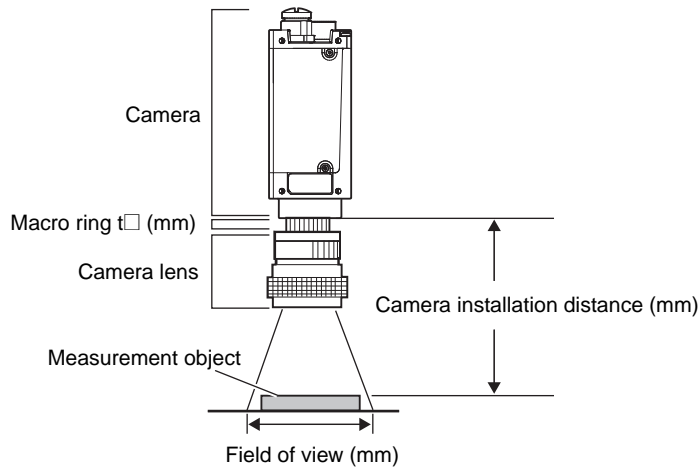

### Lens Models and Dimensions

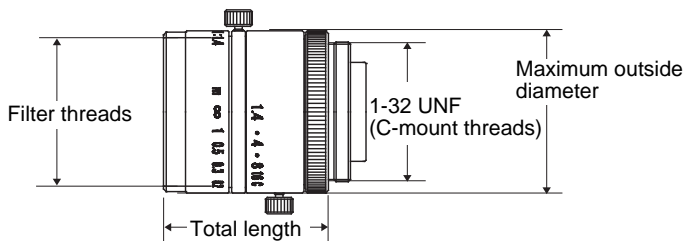

**3Z4S-LE SV-□□□□H-series High-resolution, Low-distortion Lenses**

Lens model	Focal length	Brightness	Maximum outside diameter	Total length	Filter size
3Z4S-LE SV-0614H	6.1 mm	F1.4	42 mm	57.5 mm	M40.5 P0.5
3Z4S-LE SV-0814H	8.0 mm	F1.4	39 mm	52.5 mm	M35.5 P0.5
3Z4S-LE SV-1214H	12.3 mm	F1.4	30 mm	51.0 mm	M27 P0.5
3Z4S-LE SV-1614H	16.2 mm	F1.4	30 mm	47.5 mm	M27 P0.5
3Z4S-LE SV-2514H	25.0 mm	F1.4	30 mm	36.0 mm	M27 P0.5
3Z4S-LE SV-3514H	35.01 mm	F1.4	44 mm	45.5 mm	M35.5 P0.5
3Z4S-LE SV-5014H	50.0 mm	F1.4	44 mm	57.5 mm	M40.5 P0.5
3Z4S-LE SV-7525H	75 mm	F2.5	36 mm	49.5 mm	M34.0 P0.5
3Z4S-LE SV-10028H	100 mm	F2.8	39 mm	66.5 mm	M37.5 P0.5

**3Z4S-LE SV-□□□□V-series Lenses**

Lens model	Focal length	Brightness	Maximum outside diameter	Total length	Filter size
3Z4S-LE SV-0614V	6.20 mm	F1.4	29 mm	30.0 mm	M27 P0.5
3Z4S-LE SV-0813V	8.05 mm	F1.3	28 mm	34.0 mm	M25.5 P0.5
3Z4S-LE SV-1214V	12.43 mm	F1.4	29 mm	29.5 mm	M27 P0.5
3Z4S-LE SV-1614V	16.34 mm	F1.4	29 mm	24.0 mm	M27 P0.5
3Z4S-LE SV-2514V	25.17 mm	F1.4	29 mm	24.5 mm	M27 P0.5
3Z4S-LE SV-3518V	34.75 mm	F1.8	29 mm	33.5 mm	M27 P0.5
3Z4S-LE SV-5018V	47.97 mm	F1.8	32 mm	37.0 mm	M30.5 P0.5
3Z4S-LE SV-7527V	76.71 mm	F2.7	32 mm	42.0 mm	M30.5 P0.5
3Z4S-LE SV-10035V	95.4 mm	F3.5	32 mm	43.9 mm	M30.5 P0.5

## Macro Rings

Macro rings are inserted between the Lens and the camera to adjust the focus. You can use up to seven macro rings to achieve the required thickness.

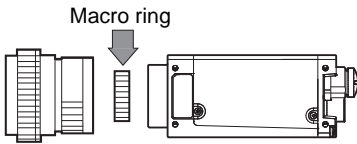

Model	Maximum outside diameter	Thickness
3Z4S-LE SV-EXR	31 mm	7-piece set Thickness: 0.5 mm   1 mm   2 mm   5 mm   10 mm   20 mm   40 mm

### Important

- Do not stack 0.5 mm, 1.0 mm, and 2.0 mm macro rings. These sizes fit between the Lens and the threaded portion of other macro rings. If two or more are stacked together, the screw cannot be tightened securely.
- The macro rings may need to be reinforced depending on the vibration conditions if over 30 mm is used.

## Installing the Touch Finder

### Installation Precautions

Install the Touch Finder in the following orientation to allow sufficient heat dissipation.



Do not mount it in the following orientations.

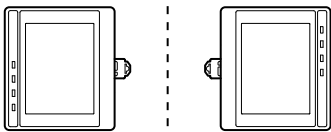

### Important

- To improve ventilation, leave space on both sides of the Touch Finder. The distance between the Touch Finder and other devices should be at least that shown in the following diagram.

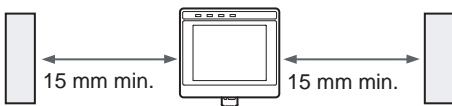

- Make sure that the ambient temperature is 50°C or lower. If it exceeds 50°C, install a cooling fan or an air conditioner and maintain the temperature at 50°C or lower.
- To prevent interference by noise, do not mount the Sensor on panels which contain high-voltage devices.
- To keep the level of noise from the surrounding environment to a minimum, install the Sensor and Touch Finder at least 10 m away from power lines.

## Mounting to DIN Track

### Installation Procedure

- 1** Press the slider on the Touch Finder to the top.
- 2** Hook the clip at the top of the Touch Finder on to the DIN Track.
- 3** Press the Touch Finder onto the DIN Track until the bottom clip clicks into place.

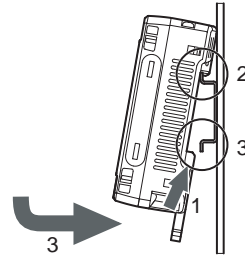

#### Important

- Attach End Plates (sold separately) on the sides of the Touch Finder on the DIN Track.
- If other devices will be installed next to the Touch Finder on the same DIN Track, make sure that sufficient space is kept between the devices as indicated on previous page.
- Always hook the clip at the top of the Touch Finder on the DIN Track first. If the lower clip is hooked on first, the Touch Finder will not be mounted very securely.

### Removal Procedure

- 1** Pull down on the slider on the Touch Finder.
- 2** Lift the Touch Finder at the bottom and remove it from the DIN Track.

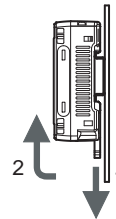

## Mounting to a Control Panel

The Touch Finder can be mounted on a panel using the FQ-XPM Panel Mounting Adapter.

#### Important

- Always turn OFF the Touch Finder power before attaching or detaching the Panel Mount Adapter. Attaching or detaching with the power turned ON may cause a failure.

- 1** Set the Touch Finder in the Panel Mount Adapter.

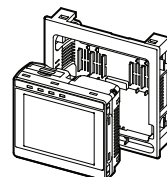

**2** Press the slider up on the Touch Finder.

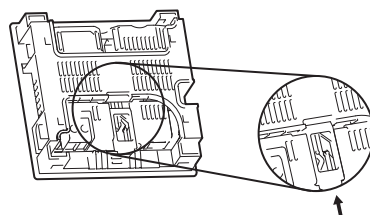

**3** Create holes in the panel for mounting.  
Refer to the following page for hole dimensions.

 p. 482

**4** Connect the cable to the Touch Finder.

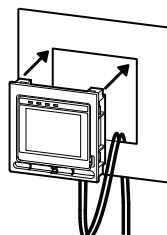

**5** Mount the Touch Finder with the Panel Mount Adapter from the front of the panel.

**6** Hook the hooks on the Mounting Bracket in the four holes of the Panel Mount Adapter and secure them with screws. (Tightening torque: 1.2 N·m)

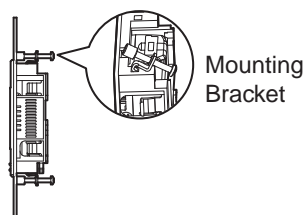

**7** Check that the Touch Finder is attached properly to the Panel.

## Using the Touch Finder as a Portable Device (with Battery)

The Touch Finder with a Battery can be used as a portable device. Use the strap when carrying it to prevent dropping it.

There are two types of straps (FQ-XH, sold separately), a Neck Strap and a Hand Strap.

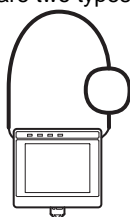

Neck Strap

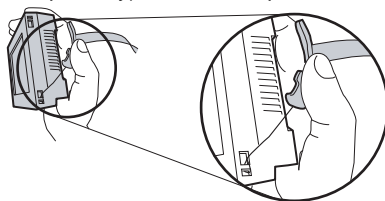

Hand Strap

**1** Attach the Mini-strap to the Touch Finder.

There are a total of four holes for attaching the Mini-strap on the left and on the right of the Touch Finder.

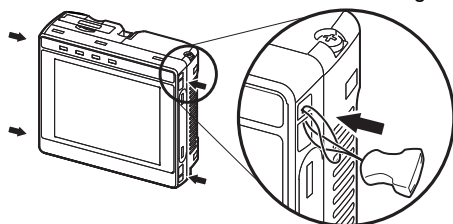

## 2 Connect the Neck Strap or Hand Strap to the Mini-strap.

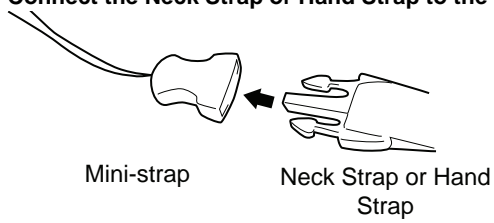

# Mounting Sensor Data Units

## Mounting to DIN Track

### Installation Procedure

- 1** Lock the sliders at the top and bottom of the Sensor Data Unit.
- 2** Press the slider on the Sensor Data Unit to the top.
- 3** Hook the clip at the top of the Sensor Data Unit on to the DIN Track.
- 4** Press the Sensor Data Unit onto the DIN Track until the bottom clip clicks into place.

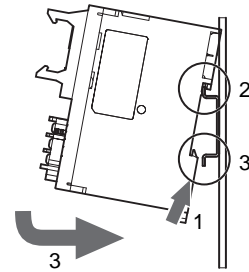

### Important

- Attach End Plates (sold separately) on the sides of the Sensor Data Unit on the DIN Track.
- Always hook the clip at the top of the Sensor Data Unit on the DIN Track first. If the lower clip is hooked on first, the Touch Finder will not be mounted very securely.

### Removal Procedure

- 1** Pull down on the slider on the Sensor Data Unit.
- 2** Lift the Sensor Data Unit at the bottom and remove it from the DIN Track.

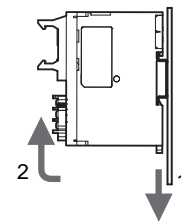

# 2-4 Wiring

## Wiring the Sensor

Connect the I/O Cable to the I/O Cable connector located at the bottom of the Sensor.

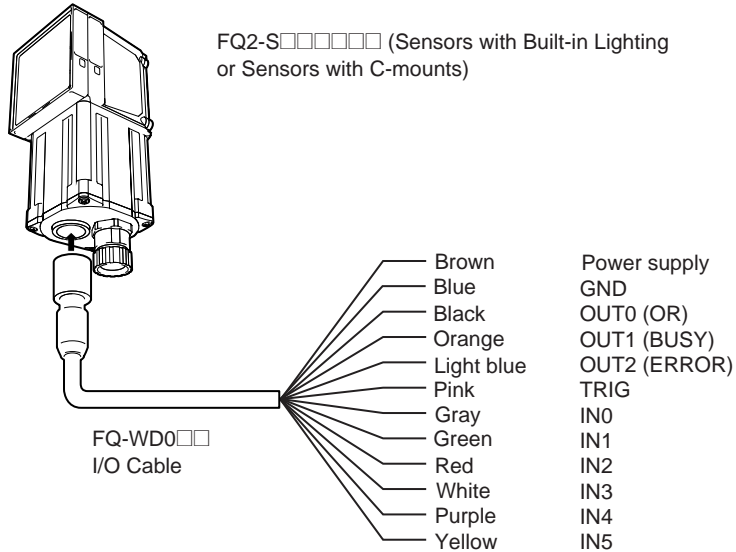

**Important**

- Cut off lines that are not required so that they do not come into contact with the other signal lines.
- Do not allow the load current to exceed 50 mA. The output circuit may be damaged if the load current exceeds 50 mA.

Classification	Signal	Application
Power supply	Power supply (24 V)	These terminals are for the external power supply (24 V).
	GND	<b>Important</b> Wire the power supply separately from other devices. If the wiring for other devices is placed together or in the same duct as the wiring for the Vision Sensor, the influences of electromagnetic induction may cause the Sensor to malfunction or may damage it.
Inputs	TRIG	This terminal is the trigger signal input.
	IN0 to IN5	These are the command input terminals.
Outputs	OUT0 (OR)	By default, this is the OR output signal (overall judgement). The assignment can be changed to RUN, READY, an individual judgement signal from OR0 to OR31, the STGOUT (strobe trigger output), or an expression judgement from 0 to 31.
	OUT1 (BUSY)	By default, this is the BUSY output signal. The assignment can be changed to RUN, READY, an individual judgement signal from OR0 to OR31, the STGOUT (strobe trigger output), or an expression judgement from 0 to 31.
	OUT2 (ERROR)	By default, this is the ERROR output signal. The assignment can be changed to RUN, READY, an individual judgement signal from OR0 to OR31, the STGOUT (strobe trigger output), or an expression judgement from 0 to 31.

**Note**

The assignments of I/O signals can be changed.

Section 8 Controlling Operation and Outputting Data with a Parallel Connection: p. 233



## I/O Signal Circuit Diagrams

NPN

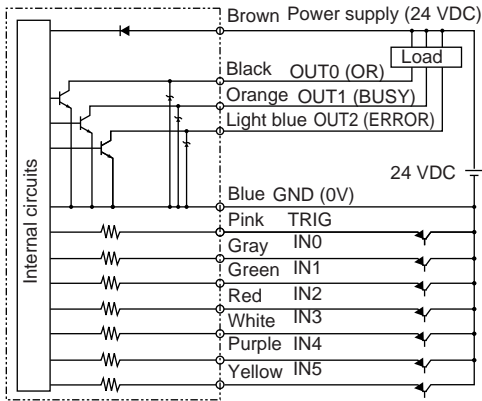

PNP

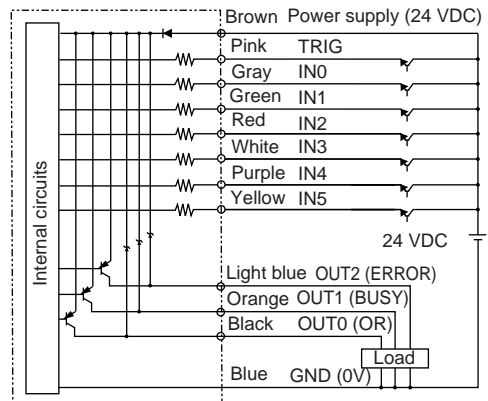

### Important

#### Preventing Chattering

- The Sensor is equipped with an anti-chattering function, but if the chattering is 100  $\mu$ s or longer, a faulty input may occur. (Input signals of 99  $\mu$ s or shorter are ignored. Signals of 100  $\mu$ s or longer are treated as input signals.)
- Use no-contact output devices (e.g., SSR or PLC transistor output) for the input signals. If contacts (e.g., relay) are used, chattering may cause the trigger to be input again during execution of a measurement.

## Power Supply Specifications When a Switching Regulator Is Connected

Use a power supply that meets the following specifications. (The power supply is sold separately.)

Item	Description	
	FQ2-S2□□□□□	FQ2-S3□-□
Power supply voltage	24 VDC (21.6 to 26.4 V)	
Recommended Power Supply	S8VS-06024□ (24 VDC, 2.5 A)	S8VS-01524□ (24 VDC, 0.65 A)
External power supply terminal screws	M4 (tightening torque: 1.2 N·m)	

### Important

Supply power from a DC power supply for which measures have been applied to prevent high voltages (e.g., a safety extra low voltage circuit).

If UL certification is required for the overall system, use a UL Class II DC power supply.

## Attaching the LED Warning Label

Attach the enclosed LED warning label to the cable or other location. The LED warning label must be attached to a location that is readily visible from the Sensor.

Attachment Example

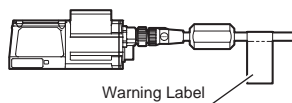

Warning Label

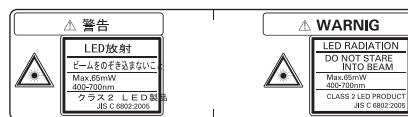

12-6 LED Safety: p. 497

# Wiring Sensor Data Units

## Parallel Interface Sensor Data Unit (FQ-SDU1□□)

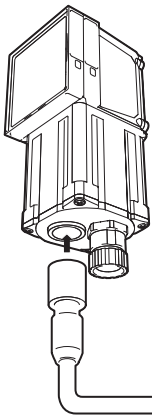

FQ2-S3 (Sensors with Built-in Lighting or Sensors with C-mounts)

FQ-WU0□□  
Sensor Data Unit Cable

(Screw size: M3,  
Tightening torque:  
0.54 N·m)

- Power supply (24 V)
- Power supply (0 V)
- Frame ground

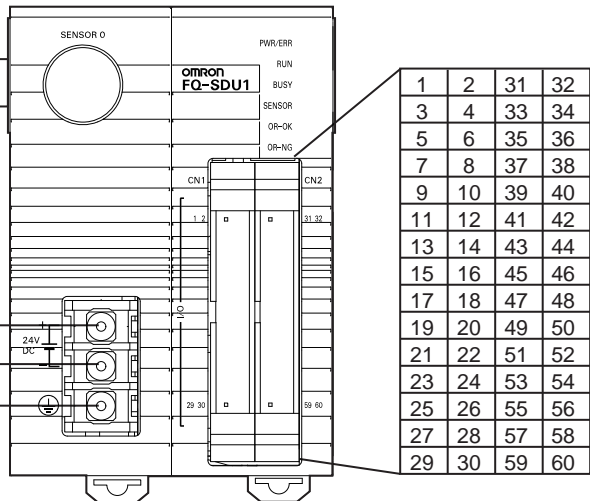

For the I/O connector harness, use an FQ-VP1□□□ Parallel Cable for the FQ-SDU1 or a MIL-standard harness, such as the OMRON XZ2F. (The Cables are sold separately.)

Signal	Application
Power supply (24 V)	These terminals are for the external power supply (24 V).
Power supply (0 V)	
Frame ground	This is the frame ground terminal. Connect it to the ground wire.

**Important**

- Wire the power supply separately from other devices. If the wiring for other devices is placed together or in the same duct as the wiring for the Vision Sensor, the influence of electromagnetic induction may cause the Sensor to malfunction or may damage it.
- Do not allow the load current to exceed 50 mA. The output circuit may be damaged if the load current exceeds 50 mA.

## FQ-SDU10/SDU15 Terminal Signal Names

Pin	Signal	IN/OUT	Function
1	COMOUT1	-	Output signal common (DO0 to DO15)
2	NC <sup>*1</sup>	-	
3	D0	OUT	Data output
4	D1	OUT	Data output
5	D2	OUT	Data output
6	D3	OUT	Data output
7	D4	OUT	Data output
8	D5	OUT	Data output
9	D6	OUT	Data output
10	D7	OUT	Data output
11	D8	OUT	Data output
12	D9	OUT	Data output
13	D10	OUT	Data output
14	D11	OUT	Data output
15	D12	OUT	Data output
16	D13	OUT	Data output
17	D14	OUT	Data output
18	D15	OUT	Data output
19	NC <sup>*1</sup>	-	
20	NC <sup>*1</sup>	-	
21	NC <sup>*1</sup>	-	
22	NC <sup>*1</sup>	-	
23	NC <sup>*1</sup>	-	
24	NC <sup>*1</sup>	-	
25	NC <sup>*1</sup>	-	
26	NC <sup>*1</sup>	-	
27	NC <sup>*1</sup>	-	
28	NC <sup>*1</sup>	-	
29	NC <sup>*1</sup>	-	
30	NC <sup>*1</sup>	-	

Pin	Signal	IN/OUT	Function
31	COMIN0	-	Input signal common (all inputs except TRIG)
32	COMIN1	-	Input signal common (TRIG)
33	TRIG	IN	Measurement trigger input
34	NC <sup>*1</sup>	-	
35	NC <sup>*1</sup>	-	
36	RESET	IN	Reset input
37	IN0	IN	Command input
38	IN1	IN	Command input
39	IN2	IN	Command input
40	IN3	IN	Command input
41	IN4	IN	Command input
42	IN5	IN	Command input
43	IN6	IN	Command input
44	IN7	IN	Command input
45	NC <sup>*1</sup>	-	
46	NC <sup>*1</sup>	-	
47	DSA	IN	Data send request signal
48	NC <sup>*1</sup>	-	
49	NC <sup>*1</sup>	-	
50	NC <sup>*1</sup>	-	
51	NC <sup>*1</sup>	-	
52	ACK	OUT	Command execution completed flag
53	RUN	OUT	ON during measurement mode
54	BUSY	OUT	ON during process execution
55	OR	OUT	Overall judgement result
56	ERROR	OUT	ON during error
57	STGOUT	OUT	Strobe trigger output <sup>*2, *3</sup>
58	SHTOUT	OUT	Shutter trigger output <sup>*4</sup>
59	GATE	OUT	ON during the set output time.
60	COMOUT0	-	Output signal common (ACK, RUN, BUSY, OR, ERROR, STGOUT, SHTOUT, and GATE)

\*1: Leave all signal terminals that are labeled "NC" open.

\*2: You can select whether to turn the external lighting ON (Positive) or OFF (Negative) when the signal turns ON. (The setting is called the strobe output polarity.)

 Changing the Output Timing and Output Time of the STGOUT Signal: p. 270

\*3: This control signal is used to turn ON external lighting when an image is taken. Connect this signal to external lighting.

\*4: This signal is output to an external device when exposure of the imaging elements is completed. If you want to move the Sensor to the next measurement location after a measurement is completed, move the Sensor only after this signal turns ON.

### Shutter Output Signal (SHTOUT)

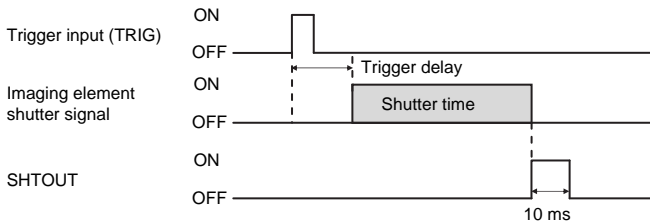

The SHTOUT signal turns ON for approximately 10 ms (fixed) when the shutter time (exposure period) elapses after the trigger is input from an external device.

## RS-232C Interface Sensor Data Unit (FQ-SDU2□)

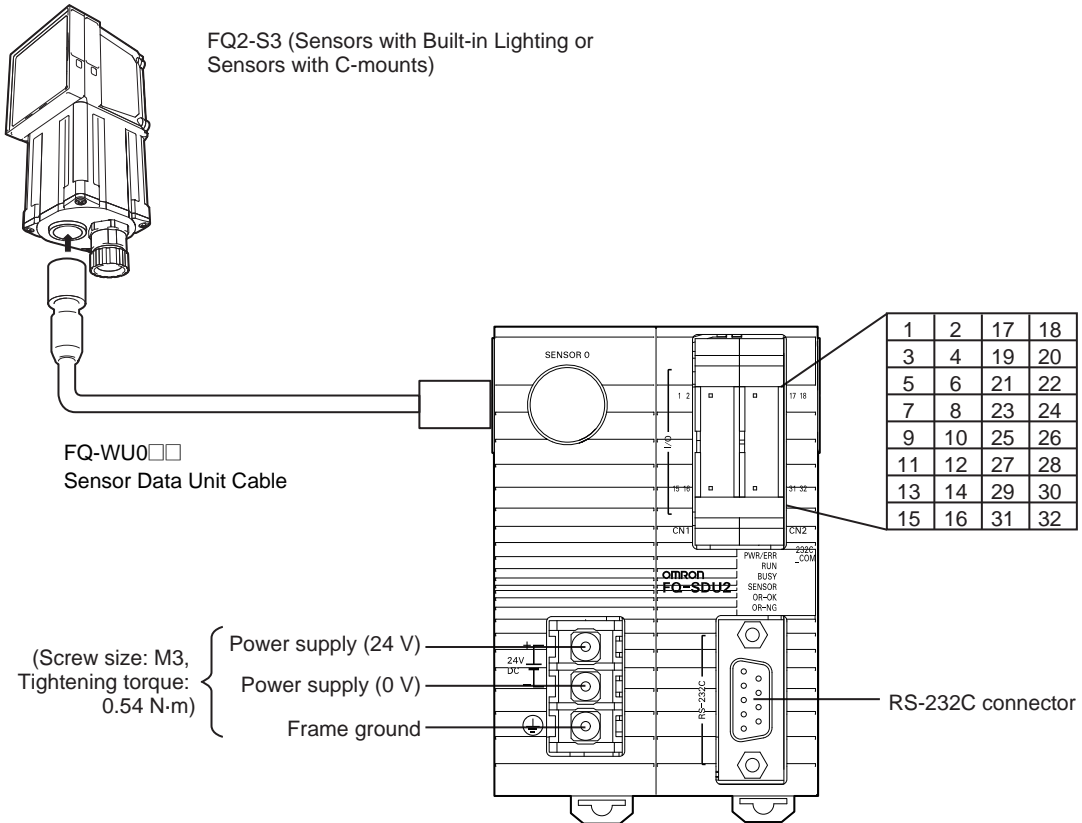

For the I/O connector harness, use an FQ-VP2□□□ Parallel Cable for the FQ-SDU2 or a MIL-standard harness, such as the OMRON XZ2F. (The Cables are sold separately.)

Signal	Application
Power supply (24 V)	These terminals are for the external power supply (24 V).
Power supply (0 V)	
Frame ground	<p><b>Important</b></p> <ul style="list-style-type: none"> <li>• Wire the power supply separately from other devices. If the wiring for other devices is placed together or in the same duct as the wiring for the Vision Sensor, the influence of electromagnetic induction may cause the Sensor to malfunction or may damage it.</li> <li>• Do not allow the load current to exceed 50 mA. The output circuit may be damaged if the load current exceeds 50 mA.</li> </ul>
Frame ground	This is the frame ground terminal. Connect it to the ground wire.

## FQ-SDU20/SDU25 Parallel Pin Signal Names

Pin	Signal	IN/ OUT	Function
1	IN0	IN	Command input
2	IN1	IN	Command input
3	IN2	IN	Command input
4	IN3	IN	Command input
5	IN4	IN	Command input
6	IN5	IN	Command input
7	NC <sup>*1</sup>	-	
8	NC <sup>*1</sup>	-	
9	NC <sup>*1</sup>	-	
10	NC <sup>*1</sup>	-	
11	NC <sup>*1</sup>	-	
12	NC <sup>*1</sup>	-	
13	NC <sup>*1</sup>	-	
14	NC <sup>*1</sup>	-	
15	NC <sup>*1</sup>	-	
16	NC <sup>*1</sup>	-	

Pin	Signal	IN/ OUT	Function
17	COMIN0	-	Input signal common (RESET and IN0 to IN5)
18	COMIN1	-	Input signal common (TRIG)
19	TRIG	IN	Measurement trigger input
20	NC <sup>*1</sup>	-	
21	NC <sup>*1</sup>	-	
22	RESET	IN	Reset input
23	NC <sup>*1</sup>	-	
24	ACK	OUT	Command execution completed flag
25	RUN	OUT	ON during measurement mode
26	BUSY	OUT	ON during process execution
27	OR	OUT	Overall judgement result
28	ERROR	OUT	ON during error
29	STGOUT	OUT	Strobe trigger output
30	SHTOUT	OUT	Shutter trigger output
31	NC <sup>*1</sup>	-	
32	COMOUT0	-	Output signal common (ACK, RUN, BUSY, OR, ERROR, STGOUT, and SHTOUT)

\*1: Leave all signal terminals that are labeled "NC" open.

## FQ-SDU20/SDU25 RS-232C Pin Signal Names

### RS-232C Connector

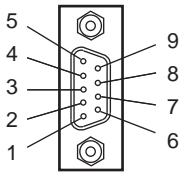

Pin No.	Signal name	Function
1	NC	Not connected
2	RD	For RS-232C
3	SD	For RS-232C
4	NC	Not connected
5	GND	Signal ground
6	NC	Not connected
7	NC	Not connected
8	NC	Not connected
9	NC	Not connected

Pin numbers will depend on the external device being connected. Refer to the manual for the personal computer or PLC being connected.

Use a compatible connector.

- Recommended items

	Manufacturer	Model
Socket	OMRON Corporation	XM3D-0921
Hood	OMRON Corporation	XM2S-0913

## Wiring

The maximum cable length is 15m.

- RS-232C

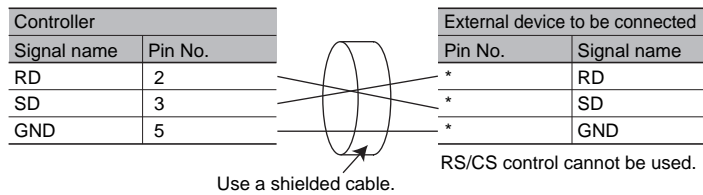

## Connection Method

Align the connector with the socket and press it straight into place, then fix it with the screws on both sides of the connector.

### Important

Turn OFF the power supply before connecting or disconnecting a Cable. Peripheral devices may be damaged if the cable is connected or disconnected with the power ON.

## I/O Signal Circuit Diagrams

### NPN

Input Circuit

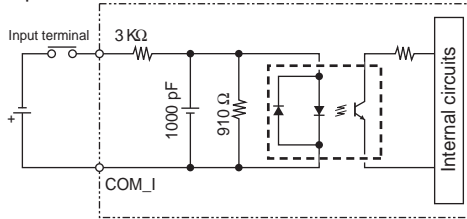

Output Circuit

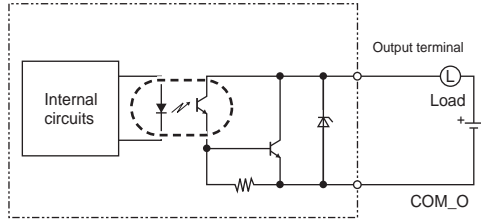

### PNP

Input Circuit

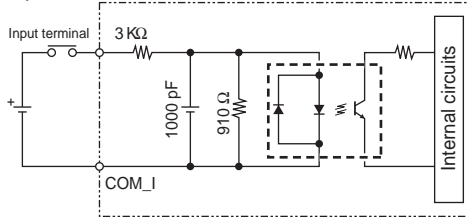

Output Circuit

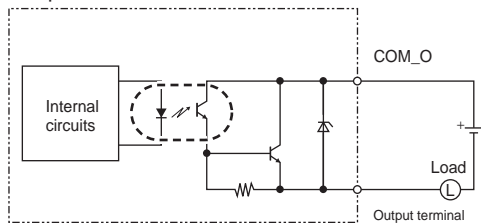

### Important

#### Preventing Chattering

- The Sensor is equipped with an anti-chattering function, but if the chattering is 100 μs or longer, a faulty input may occur. (Input signals of 99 μs or shorter are ignored. Signals of 100 μs or longer are treated as input signals.)
- Use no-contact output devices (e.g., SSR or PLC transistor output) for the input signals. If contacts (e.g., a relay) are used, chattering may cause the trigger to be input again during execution of a measurement.

## Power Supply Specifications When a Switching Regulator Is Connected

Use a power supply that meets the following specifications. (They are sold separately.)

Item	Description	
	FQ2-S2□□□□□□ connection	FQ2-S3□-□ connection
Power supply voltage	24 VDC (21.6 to 26.4 V)	
Recommended Power Supplies	S8VS-06024□ (24 VDC, 2.5 A)	S8VS-03024 (24 VDC, 1.3 A)
External power supply terminal screws	M4 (tightening torque: 1.2 N·m)	

### Important

Supply power from a DC power supply for which measures have been applied to prevent high voltages (e.g., a safety extra-low-voltage circuit).

If UL certification is required for the overall system, use a UL Class II DC power supply.

# Wiring the Touch Finder

## Power Supply Wiring

### Connecting the Power Supply

- 1** Loosen the two terminal screws using a Phillips screwdriver.
- 2** Attach crimp terminals to the power lines. Secure the positive and negative lines as indicated using M3 screws.  
Power supply tightening torque: 0.54 N-m
- 3** In environments where there is excessive noise, attach a ferrite core (ZCAT1730-0730 from TDK or the equivalent) to the power supply cable.

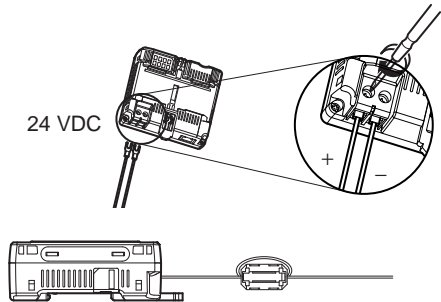

When you attach the ferrite core to the power supply cable, wrap the cable only one time.

### Turning ON the Touch Finder

- 1** Remove the cover from the power switch on the left side of the Touch Finder.
- 2** Press the switch toward **ON**.

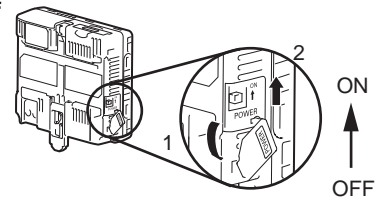

### Power Supply Specifications

Use a power supply that meets the following specifications. (The power supply is sold separately.)

Item	Description
Power supply voltage	24 VDC (21.6 to 26.4 V)
Output current	0.65 A min.
Recommended Power Supply	S8VS-01524□ (24 VDC, 0.65 A)
External power supply terminal screws	M3.5 (tightening torque: 1.0 N-m)
Recommended power line wire size	AWG16 to AWG22 (length of 5 m max.)

#### Important

- Supply power from a DC power supply for which measures have been applied to prevent high voltages (e.g., a safety extra-low-voltage circuit).  
If UL certification is required for the overall system, use a UL Class II DC power supply.
- When using the FQ-D31, do not connect a switching regulator and AC Adapter (FQ-AC□) at the same time.



## Charging the Battery

This section describes how to charge and install the FQ-D31 Battery and provides applicable precautions.

Charge the Battery while it is attached to the Touch Finder.

Use the AC adapter to charge the battery.

### Mounting the Battery in the Touch Finder

- 1 Remove the screw from the battery cover on the top of the Touch Finder, slide the cover in the direction of the arrow, and open the battery cover.

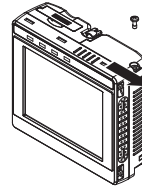

- 2 Face the rounded side of the battery toward the back of the Touch Finder and insert the battery.

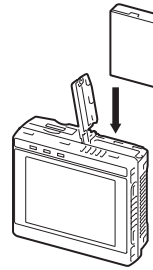

#### Important

Do not insert the battery in the wrong orientation.

- 3 Close the battery cover, slide the battery cover in the direction of the arrow, and tighten the screw on the battery cover.

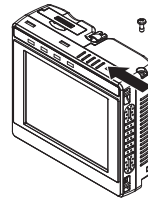

- 4 Attach the AC adapter to the Touch Finder to start charging the battery.

The CHARGE indicator will be lit while the battery is being charged. It will go out when charging the battery has been completed.

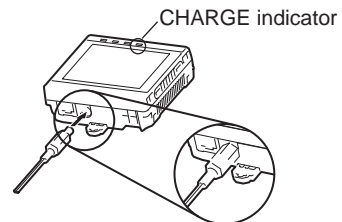

#### Note

The Touch Finder will operate even if the AC adapter is connected when no battery is mounted in the Touch Finder.

## Important

- If the Touch Finder (FQ-D31) will be installed permanently or semi-permanently, remove the Battery (FQ-BAT1). If the rated temperature is exceeded with the Battery inserted, the protective circuit may activate and stop the Touch Finder.
- The battery complies with the following recycling regulation.

Japan



Li-ion00

EU



Taiwan



- California regulations concerning perchlorate:

This product is a lithium battery that contains perchlorate, which is regulated by the State of California. Please comply with these regulations. For details see the following URL:

[www.dtsc.ca.gov/hazardouswaste/perchlorate/](http://www.dtsc.ca.gov/hazardouswaste/perchlorate/)

## 2-5 Setting Up Ethernet

### Connecting to Sensors from the Touch Finder

#### Configurations Consisting of Only Sensors and the Touch Finder

When only Sensors and a Touch Finder are used, IP addresses are automatically assigned. No settings are required to use Ethernet.

#### Connections on Existing Networks

If a Sensor or Touch Finder is connected to a network where a PLC or computer is already connected, the Ethernet settings must be made compatible with the existing network.

Set the IP addresses with one of the following methods.

- Setting Fixed IP Addresses

- Sensor

▶  (Setup Mode) – [Sensor settings] – [Network] – [Ethernet] – [IP address setting]

**1** Press [Fixed].

**2** Set the IP address and subnet mask according to the network settings.

Note

- 
- If you connect the Touch Finder or PC Tool to a Sensor on a different network through a router, set fixed IP addresses.
  - If you use an EtherNet/IP connections, set fixed IP address for the Sensors.
- 

- Touch Finder

▶  (Setup Mode) – [TF settings] – [Ethernet] – [IP address setting]

**1** Press [Fixed].

**2** Set the IP address and subnet mask according to the network settings.

- Using a DHCP Server

- Sensor

▶  (Setup Mode) – [Sensor settings] – [Network] – [Ethernet] – [IP address setting]

**1** Press [DHCP].

- Touch Finder

▶  (Setup Mode) – [TF settings] – [Ethernet]] – [IP address setting]

**1** Press [DHCP].

## Connecting to Sensors from External Devices Such as PLCs

Set the IP address of the Sensor according to the network where the external devices, such as PLCs, are connected.

▶  (Setup Mode) – [Sensor settings] – [Network] – [Ethernet] – [IP address setting]

- 1** Press [Fixed].
- 2** Set the IP address and subnet mask according to the network where the external devices, such as PLCs, are connected.

### Note

If you connect OMRON CS/CJ-series PLCs to the Ethernet, the following default IP addresses are assigned to the PLCs.

- IP address: 192.168.250.*node\_address*

## Connecting to Sensors from a Computer Using the PC Tool

### Configurations Consisting of Only Sensors and a Computer (PC Tool)

If the configuration consists only of Sensors and a Touch Finder, set the network settings on the computer as described below.

(No IP address settings are required on the Sensors.)

The following procedure is for Windows XP.

- 1** Select [Control Panel] from the Windows Start Menu.
- 2** Click [Network and Internet Connections] in the control panel and then double-click [Network Connections].
- 3** Right-click the [Local Area Connection] icon and select [Properties].

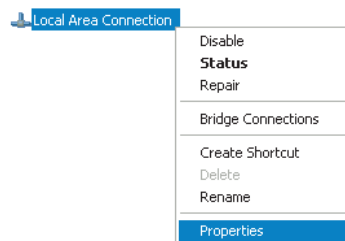

**4** On the [General] Tab Page, double-click *Internet Protocol (TCP/IC)*.

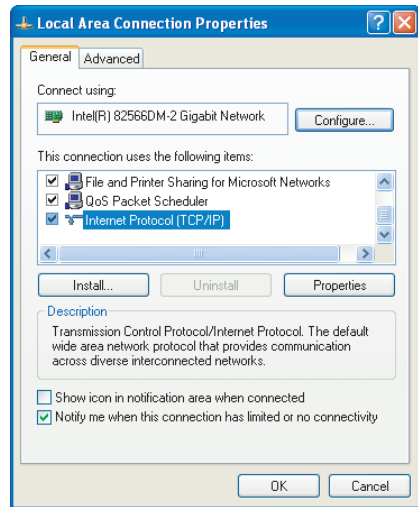

**5** Select the *Use the following IP address* Option and enter the following IP address and subnet mask.

- IP address: 10.5.5.101
- Subnet mask: 255.255.255.0

**6** Click the [OK] Button. This completes the settings.

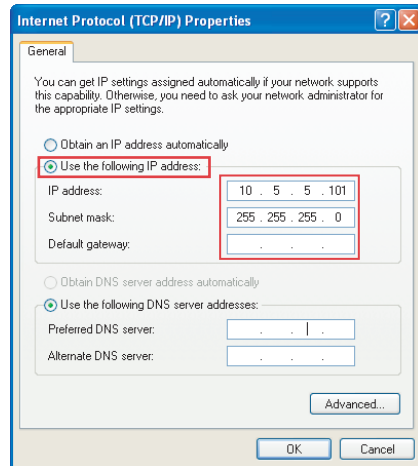

## Connections on Existing Networks

Set the Ethernet settings of the Sensors and the computer (PC Tool) to the same settings as the existing network. Refer to *Connecting to Sensors from the Touch Finder* on page 53 for the IP address settings in the Sensors.

**Note**

- If you connect the PC Tool to a Sensor on a different network through a router, set fixed IP addresses.
- If you use an EtherNet/IP connections, set fixed IP address for the Sensors.

MEMO



# Taking Images

---

<b>3-1 Selecting a Sensor for Configuration</b> .....	<b>58</b>
<b>3-2 Setting Conditions for Taking Images</b> .....	<b>59</b>
<b>3-3 Adjusting Image Quality</b> .....	<b>60</b>
<b>3-4 Adjusting the Timing of Taking Images</b> .....	<b>66</b>
<b>3-5 Adjusting the Images That Were Taken</b> .....	<b>68</b>

# 3-1 Selecting a Sensor for Configuration

If multiple Sensors are connected to a single Touch Finder or computer, a list of the Sensors that are connected is displayed by default. Use the following procedure to change to the Sensor to set up.

- 1 Press  – [Switch Sensor].
- 2 Press the image of the Sensor to be set up.  
 will be displayed for Sensors that are not yet set.

**Note**

Once the Touch Finder detects and records a Sensor, the display order for showing more than one Sensor is fixed. Even if the system configuration is changed to reduce the number of Sensors, the previous display location will remain for Sensors that were removed. To update displays of multiple Sensors to the current connection status, press [◀] - [Auto connect] on the right of the display in step 2, to automatically reconnect.

- 3 Press  – [Sensor settings] to return to Setup Mode.

- 4 Press [Yes].

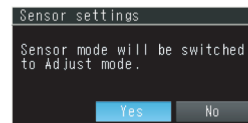
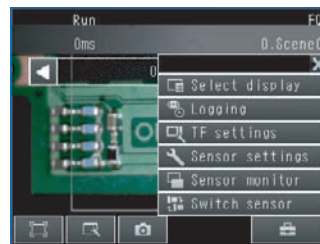
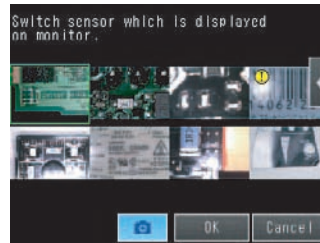

**Note**

There are different methods that you can use to connect the Sensors. For example, you can automatically connect to the Sensors that are recognized by the Touch Finder, or you can manually register the Sensors to connect.





 7-5 Connecting to More Than One Sensor: p. 204



# 3-2 Setting Conditions for Taking Images

You can set the conditions for taking images to use in inspections.



To enable accurate judgements, the following adjustments are made for the conditions for taking images and the images themselves.

Taking Clear Images (Camera Setup)	
Adjusting the Focus  p. 60	
Adjust the focus of the Lens.	
Taking Bright Images of Dark Objects and Taking Clear Images of Moving Objects  p. 63	
Adjust the shutter speed and gain.	
Improving the Image Quality of Metallic and Other Shiny Surfaces (HDR)  p. 64	
Make adjustments for shiny objects or metallic surfaces. For a Sensor with built-in lighting, attach a polarizing filter to cut specular reflections.	
Adjusting the Colors of the Image (White Balance)  p. 65	
Adjust the white balance so that the colors match those of the actual measurement object.	



Adjusting the Timing of Taking Images (Trigger Setting)	
Trigger Delay  p. 66	
Adjust the timing of taking an image with the Sensor.	



Adjusting the Images That Were Taken (Image Adjustment)	
Filtering the Images (Filter Items)  p. 69	
Apply filters to adjust the images that were taken.	
Compensating for Position Offset (Position Compensation Items)  p. 74	
Recognize measurement objects that are not in a consistent location and move them to the center of the image.	

# 3-3 Adjusting Image Quality

## Adjusting the Focus

### ► [Image] – [Camera setup]

#### 1 Display the Camera Setup Display.

The focus can be seen as a numerical value. The higher the value, the better the focus.

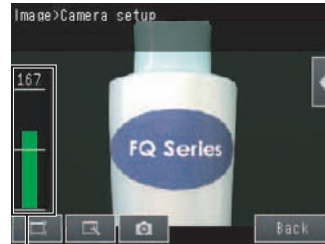

Focus Level

#### 2 Adjust the focus of the Sensor while checking the image and focus value on the Touch Finder.

For a Sensor with Built-in Lighting, manually adjust the focus using the focus adjustment screw on the Sensor. In the default settings, the field of view is set to the narrowest setting. For a Sensor with a C-mount, use the focus ring on the lens to adjust the focus of the image.

#### 3 Press [Back].

Focus adjustment screw

Turn clockwise to focus on closer objects.

(The field of view will narrow.)



Turn the screw counterclockwise to focus on objects at a distance.

(The field of view will widen.)

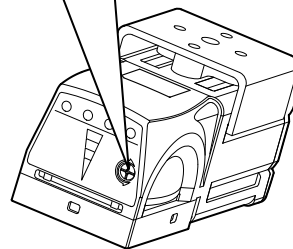

Sensor with Built-in Lighting

### Important

- Turn the focus adjustment screw clockwise or counterclockwise a little bit to make sure that it has not already reached the dead stop. Do not force the screw if it does not rotate anymore. This will damage the Sensor.
- Do not turn the focus adjustment screw with a force that is greater than 0.1 N·m. This may damage it.

## Adjusting Image Brightness with External Lighting

You can adjust image brightness with external lighting or by setting the Sensor sensitivity.

### Using a Strobe Trigger Signal to Control External Lighting

If a Data Unit is connected, you can change the output time of the strobe trigger signal (STGOUT) to adjust the brightness.

 Changing the Output Timing and Output Time of the STGOUT Signal: p. 270

## Adjusting the Brightness

You can adjust the shutter speed/gain or the brightness to make images brighter. The setting method depends on whether HDR Mode is ON or OFF. The setting methods are described below.

 HDR Function: p. 64

### Important

The exposure time will be longer for higher values of the shutter speed or brightness. This may cause the image to blur if the object is moving fast. If the Sensor is used on a high-speed line, check that the images are not blurred under actual operating conditions.

## Brightness Correction Mode (FQ2-S1□□□□□□/ FQ2-S2□□□□□□)

If the brightness changes inconsistently with each image, turn ON the Brightness Correction Mode.

When HDR is ON: ► [Brightness] – ◀ – [Brightness correction]

When HDR is OFF: ► [Gain] – ◀ – [Brightness correction]

When the Brightness Correction Mode is ON, the brightness will be consistent but the timing when images are taken will be delayed by 25 ms. Make sure that appropriate images of the measured objects are taken when the Brightness Correction Mode is ON.

Timing Chart When the Brightness Correction Mode Is ON

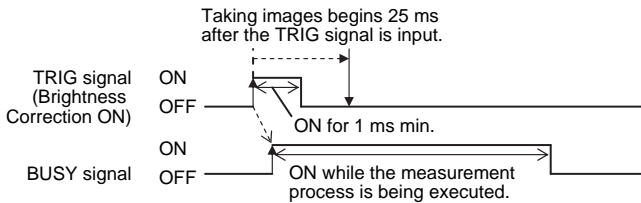

 Reference Timing Chart When the Brightness Correction Mode Is OFF: p. 236

### Important

If the gain is increased, the brightness will not be stable and measurement values may be inconsistent. We recommend that you turn ON the Brightness Connection Mode.

## When HDR Is OFF

The brightness of the image is adjusted by adjusting the shutter speed. If the brightness cannot be improved by adjusting the shutter speed, the gain is adjusted.

Relationship between the Shutter Speed/Gain and the Image Brightness

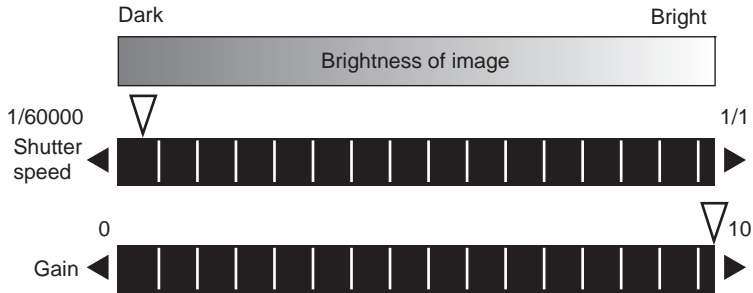

### Note

- Adjust the shutter speed not only to adjust the brightness of the image, but also to adjust for the travel speed of the measurement object.

Taking Clear Images of Moving Objects: p. 63

- Increasing the gain will make the image brighter, but it will also reduce image quality to the point that the noise component in the images will stand out. Select a suitable factor for the inspection.

### ► [Image] – [Camera setup]

- Press [**◀**] – [Shutter speed] on the right of the display.
- Move the bar to the left or right to adjust the shutter speed.  
Moving it to the left will make the shutter speed slower and the image brighter. Moving it to the right will make the shutter speed faster and the image darker.
- Press [OK].  
If you cannot obtain the required brightness by adjusting the shutter speed, adjust the gain
- Press [**◀**] – [Gain] on the right of the display.
- Move the bar to the left or right to adjust the gain.  
Moving it to the right will increase the gain and make the image brighter. Moving it to the left will reduce the gain and make the image darker.
- Press [OK].
- Press [Back].



Parameter	Setting	Description
Shutter speed	Range: For FQ-S3 1/1 to 1/60,000 1/250 to 1/60,000 (for Cameras with Built-in Lighting) For FQ2-S1 or FQ2-S2 1/1 to 1/50,000 1/250 to 1/50,000 (for Cameras with Built-in Lighting) Default: 1/250	If the shutter speed is slow, the image will be bright. If the shutter speed is fast, the image will be dark.

Parameter	Setting	Description
Gain	For FQ-S3 Range: 0 to 10 Default: 0 For FQ2-S1 or FQ2-S2 Range: 16 to 64 Default: 16	If the gain is high, the image will be bright. If the gain is low, the image will be dark.

**Important**

- To ensure stable operation when the FQ2-S1 or FQ2-S2 is connected, we recommend that you set the gain to 16.
- If the recommended value is exceeded, the brightness will not be stable and measurement values may be inconsistent. We recommend that you turn ON the Brightness Connection Mode.
- If a slow shutter speed (1/1 to 1/10) and a high gain are set, fixed-pattern noise (fleck and striped noise) will sometimes occur. Be sure to thoroughly check the images and the measurement results when you set the shutter speed and gain.

**When HDR Is ON**

Set the brightness adjustment value. The higher the brightness adjustment value, the brighter the image.

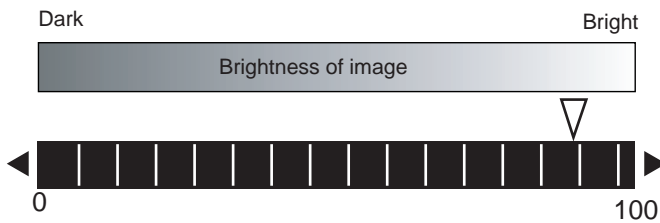

► **[Image] – [Camera setup]**

- 1 Press [◀] – [Brightness] on the right side of the display.
- 2 Move the bar to the left or right to adjust the brightness.  
Moving it to the right will make the image brighter, while moving it to the left will reduce the brightness of the image.
- 3 Press [OK].



**Taking Clear Images of Moving Objects**

For quick moving objects, the effect of blurring can be reduced by decreasing the shutter speed. In HDR Mode, set the brightness value to a low setting.

• **Relationship between Shutter Speed and the Brightness Adjustment Value in HDR Mode**

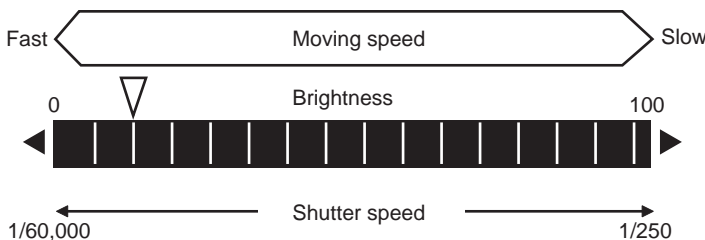

Refer to the following page for the setting methods for the shutter speed and brightness.

📖 Adjusting the Brightness: p. 61

## Important

The lower the shutter speed/gain and brightness settings are, the darker the image becomes. If the Sensor is used in a dark environment, make sure that the darkness of the image does not cause the measurements to be unstable.

## Improving the Image Quality of Metallic and other Shiny Surfaces

When objects with shiny surfaces are being measured, the lighting may be reflected off the surface and affect the image.

To remove reflections, one of the following two functions can be used.

Function	Description
HDR (High Dynamic Range)	If objects have contrasting light and dark areas, the dynamic range can be made wider to improve the quality of the images.
Polarizing filter (for Sensors with Built-in Lighting)	Specular reflections can be eliminated from an image by attaching a polarizing filter to the Sensor. If the measurement object must be moving, use a polarizing filter. Also, if reflections cannot be sufficiently removed by using the HDR function, use a polarizing filter as well.

## HDR Function

The HDR function is used for objects that have a large difference between light and dark areas. For this kind of object, clear images cannot be achieved with the standard brightness setting. The HDR function combines several images of different brightnesses (shutter speed) so that the resulting image has a lower degree of contrast and can be measured stably for the desired characteristic.

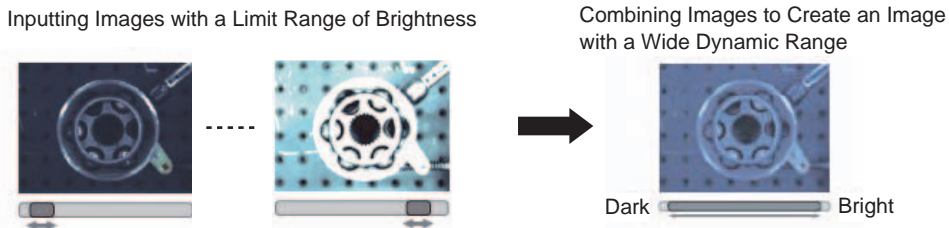

Observe the following precautions.

- Use the HDR function only for objects that are not moving to avoid image blurring. Several images are taken with different shutter speeds and combined. If the object moves while the image is being taken, the image will become blurred.
- Images with different brightnesses are combined, so the resulting image will have a lower degree of contrast.

### ► [Image] – [Camera setup]

**1** Press [◀] – [HDR] on the right side of the display.

**2** Set the best level for the HDR Mode.

As shown below, the higher the level, the wider the combined dynamic range will be.



## Using a Polarizing Filter (Only for Sensors with Built-in Lighting)

Specular reflections can be eliminated from an image by attaching an FQ-XF1 Polarizing Filter to the Sensor.

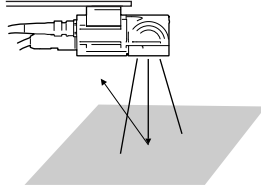

Observe the following precautions.

- The image will be darker compared to when no filter is used.
- If the image becomes too dark, adjust the brightness.

 p. 61

### • Mounting the Filter

- 1** Hook the filter in the hole at the top of the Sensor.

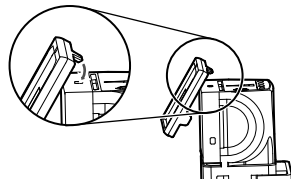

- 2** Using the top section as a pivot point, pull down the filter so that it attaches to the Sensor.

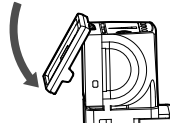

## Adjusting the Colors of the Image (White Balance) (Only for Sensors with Color Cameras)

If external lighting is used, the image may appear as having different colors than the actual object. If this is the case, adjust the white balance.

If the lighting built in to the Sensor is used, the white balance is already adjusted. No setting is required in this case.

### ► [Image] – [Camera setup]

- 1** Input a picture of white paper or cloth.
- 2** Press [**◀**] – [White balance] on the right side of the display.
- 3** Press the [Auto] Button. The Sensor will automatically adjust the colors.
- 4** Move the bar to the left (light) or right (dark) to fine-tune the colors.
- 5** Press [OK].

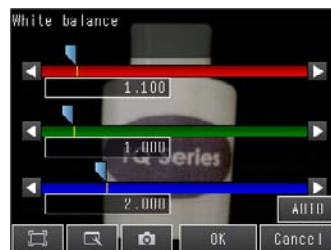

# 3-4 Adjusting the Timing of Taking Images

## Delaying the Image Capture Timing from the Trigger Input

If the measurement object is moving, the position in the image of the feature that is to be measured will depend on the timing of the trigger signal. A delay can be applied from when the trigger (i.e., the TRIG signal) is input until when the image is taken to synchronize the timing of image capture with the speed of moving objects. If the object position varies in the image, this delay cannot be used to make the object position more stable. When you use a trigger delay with external lighting, you will also need to adjust the timing to turn ON external lighting.

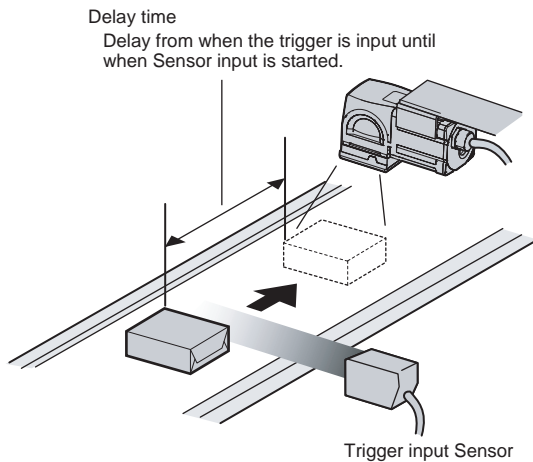

### ► [Image] – [Trigger setup] – [Trigger delay]

- 1** A TRIG signal is input.  
Images are input continuously.
- 2** Select the image with the measurement object in the center using ◀ and ▶.
- 3** Press the image.
- 4** Press [OK].

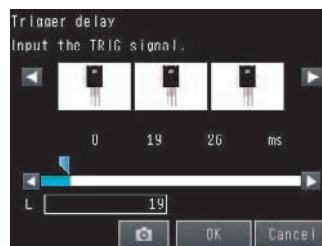

#### Note

The delay time can be set using the adjustment bar or by directly entering a value.

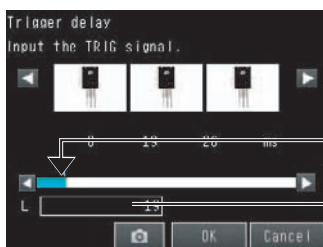

Move the bar to the left or right.

Or

Directly input the delay time.



## Adjusting External Lighting Timing

When you use a trigger delay, you must adjust the timing to turn ON external lighting so that it matches the trigger delay timing.

### Using a Strobe Trigger Signal to Control External Lighting

If a Sensor Data Unit is connected, you can change the output time of the strobe trigger signal (STGOUT) to adjust the timing of the external lighting.

 Changing the Output Timing and Output Time of the STGOUT Signal: p. 270

▶ **[Image]** – **[Camera setup]** – **[◀]** – **[Lightning control]**

### Preventing Mutual Interference of Multiple Sensors

When the same trigger signal is input to multiple Sensors, the lighting from one Sensor may affect the measurements of the other Sensors. This is called mutual interference. This kind of interference can be prevented offsetting the image input timing of each Sensor from when the trigger signal is received.

Example:

A trigger (i.e., the TRIG signal) is input to Sensor 0 and Sensor 1 at the same time.

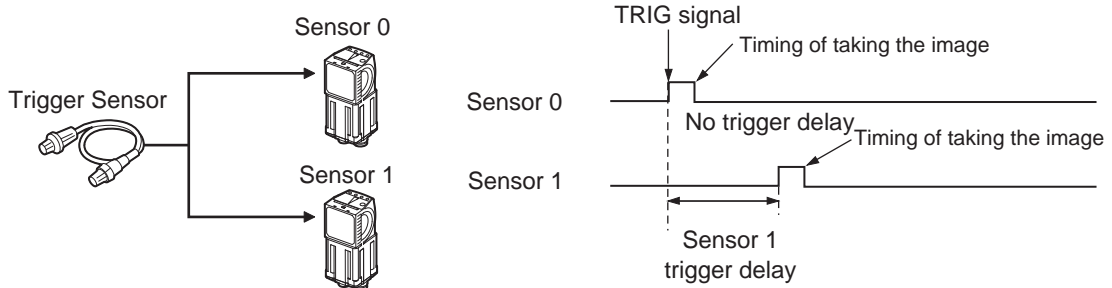

Sensor 0 immediately begins image input when the trigger is input.  
Sensor 1 begins image input after the specified time has passed.

#### 1 Change to the setup for to Sensor 1.

 p. 58

#### 2 Press **[Image]** – **[Trigger setup]** – **[Trigger delay]**.

#### 3 Set the trigger input delay time for Sensor 1.

 p. 66

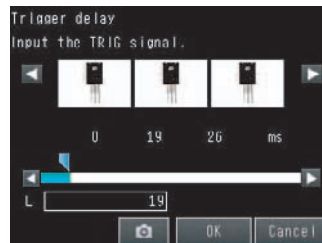

#### Important

The delay time for preventing mutual interference must be longer than the shutter time.

When the lighting built into the Sensor is used, the shutter time is 4 ms max. Therefore make the delay at least 4 ms.

# 3-5 Adjusting the Images That Were Taken

## Image Adjustment

You can adjust the image that is taken by the Sensor to make it easy to measure.

There are mainly the following two types of items that you can use to adjust the image.

- Filtering the Images (Filter Items)

These items filter the image by eliminating image noise with filters to make them suitable for measurement.

- Compensating for Position Offset (Position Compensation Items)

These items compensate for offset in the position or orientation of the image.

You can combine several filter items and position compensation items to adjust the image that was taken. (You can use a total of up to eight filter and position compensation items combined.)

## Flow of Image Adjustment

The image that is taken by the Camera (called the Camera image) is adjusted in the order that the filter and position compensation items are registered.

**Note**

You can specify the order of image adjustment by registering the items in the desired order, but you cannot change the order of the items after you register them.

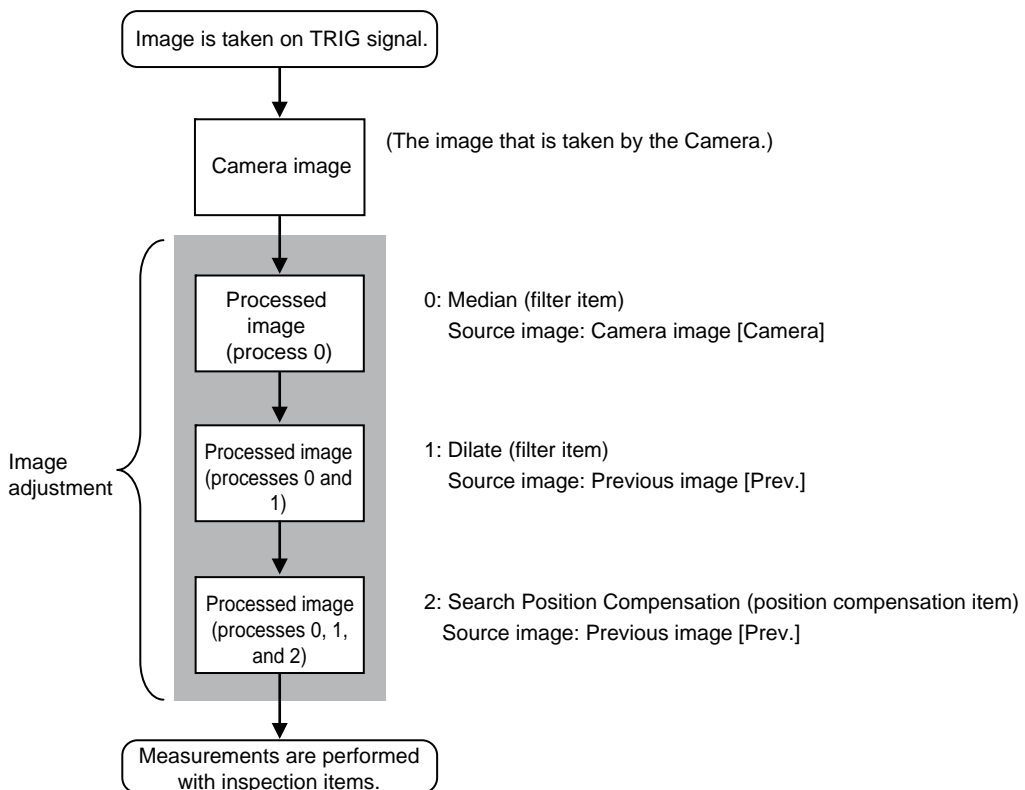

**Note**

Specify the Camera image for the first filter item for image processing.

If you execute more than one filter item for the image, set the source image for the other filter items to the previous image.

Also, you can perform image processing with filter items only to enable processing with position compensation items.

In that case, only the position information from position compensation is applied to the image to be measured.

For details, refer to Using Filter Items for Processing with Position Compensation Items on page 76.

## Filtering the Images (Filter Items)

You can filter the images that are taken by the Camera to make them easier to measure.

This is used in the following cases.

- To cut unnecessary backgrounds so that they are not measured
- To remove noise
- To stably find the edges of marks when other edges have been clearly extracted

### Applicable Filters

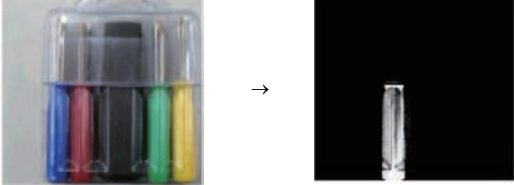
Selected filter item	Description
Color Gray Filter (only for Sensors with Color Cameras)	<p>Converts an image that was input from a Color Camera to a monochrome image. Example: You can extract an image that contains only a specific color.</p> <div style="text-align: center;">  <p>Extracting an Image That Contains Only Red</p> </div> <div style="border: 1px solid black; padding: 2px; width: fit-content; margin: 5px auto;"><b>Note</b></div> <ul style="list-style-type: none"> <li>• This inspection item cannot be used for monochrome images. An NG (image error) will result if you use it for a monochrome image.</li> <li>• All inspection items after the Color Gray Filter item will be performed in the same way as when a Monochrome Camera is connected.</li> </ul>
Weak Smoothing	Used when there are minor irregularities in the measurement object.
Strong Smoothing	The image is feathered to reduce unevenness.
Dilate	Used when there is dark noise. Dark noise is removed by dilating bright places.
Erosion	Used when there is bright noise. Bright noise is removed by eroding bright places.
Median	Used when there are minor irregularities in the measurement object. Unevenness is reduced while maintaining outlines.
Extract Edges	Extracts image edges between light and dark.
Extract Horiz. Edges (extract horizontal edges)	Extracts horizontal edges between light and dark in the image.
Extract vertical edges	Extracts vertical edges between light and dark in the image.
Enhance edges	Enhances image edges between light and dark.

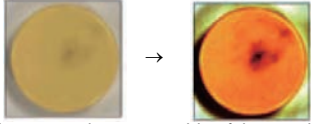
Selected filter item	Description
Background Suppression	<p>Extracts a specific range of brightness to increase the image contrast and suppress the unnecessary background. Example: Increasing Contrast</p>  <p>Any areas that are outside of the specified range of brightness are removed as the background. Also, the brightness within the specified range is converted to 255 levels to enhance the contrast.</p>

## Setting Filter Items

### ► [Image] – [Image adjustment]

- 1 Press an unused number and then press [Add filter].
- 2 Press the filter item to use.
- 3 Make any detailed settings as required for the filter.  
Refer to the detailed settings for each of the following filter items.
- 4 Press [OK].
- 5 Press [Back].
- 6 Make any the following settings as required for each filter item.



- Setting the Source Image for Filtering

 p. 70

- Setting the Region to Filter

 p. 71

- Setting the Filter Type (for Color Gray Filter Only)

 p. 71

- Setting the Brightness Range to Extract (for Background Suppression Item Only)

 p. 72

## Setting the Image to Filter (Source Image)

You must set the image to which the filter is to be applied.

### ► [Image] – [Image adjustment] – [Add filter] – (Filter item to select)

- 1 Press [◀] – [Source image] on the right of the display.
- 2 Set the source image to [Camera] or [Prev.].

Parameter	Setting	Description
Source image	Camera (camera image)	The filter is applied to the image that is taken by the Camera.
	Prev. (previous image)	The filter is applied to the image that resulted from the previous filter items or position compensation items in the processing order.

## Setting the Region to Filter

You can specify the region to which to apply the filter.  
This setting does not exist in the Color Gray Filter item.

### ► [Image] – [Image adjustment] – [Add filter] – (Filter item to select)

- 1 Press [◀] – [Filter region] on the right of the display.
- 2 Adjust the size and position of the region to which the filter is to be applied.

To fine-tune the region, press [◀] – [Console] on the right of the display to display the console. This will allow you to change the coordinates of the rectangle at the pixel level.

Drag to move the region.

Drag a corner to size the rectangle.



## Setting the Filter Type (for Color Gray Filter Only)

You can specify the ranges of colors to which the Color Gray Filter item is applied.

### ► [Image] – [Image adjustment] – [Add filter] – [Color Gray Filter]

- 1 Press [◀] – [Filter type] on the right of the display.
- 2 Set the filter type to either [RGB] or [HSV].

Parameter	Description
RGB (default)	The red, green, and blue extraction ranges are specified.
HSV	The extracted color ranges are specified with the hue and chroma (saturation).



- 3 Press [◀] – [Filter settings] on the right of the display.
- 4 Make the detailed filter settings.

- RGB
  - Select the type of color filter to use.
  - If you select [Custom filter], set the gains for red, green, and blue.



- HSV
  - Set the following ranges: [Std. Hue], [Hue range], and [Chroma].

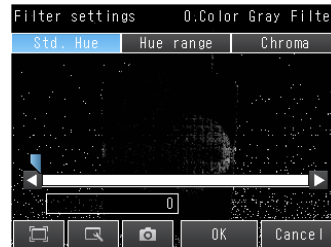

- 5 Press [OK].
- 6 Press [Back].

- RGB

Parameter	Setting	Description
Filter settings	<ul style="list-style-type: none"> <li>• Red filter (default)</li> <li>• Green filter</li> <li>• Blue filter</li> <li>• Cyan filter</li> <li>• Magenta filter</li> <li>• Yellow filter</li> <li>• Brgt.F (brightness filter) (R+G+B)</li> <li>• Brgt.F (brightness filter) (R+2G+B)</li> <li>• Custom filter</li> </ul>	These filters achieve the same effect as when using the selected optical filter.
R	Range: 0.0001 to 9.9999 Default: 0.3000	These are the RGB gain settings for a custom filter. Increase the gain to increase the density of that color component. You can set the gains only if [Custom filter] is selected in the filter settings.
G	Range: 0.0001 to 9.9999 Default: 0.5900	
B	Range: 0.0001 to 9.9999 Default: 0.1100	

- HSV

Parameter	Setting	Description
Std. Hue (standard hue)	Range: 0 to 359 Default: 0	Sets the standard hue for the HSV filter. The density will decrease as the difference between the hue and the standard hue increases.
Hue range	Range: 10 to 180 Default: 90	Sets the hue range for the HSV filter. The hue range centered on the standard hue is divided into 255 levels to find the difference in the hue. Hues that are outside the hue range will have a density of 0.
Chroma (saturation)	Range: 0 to 255 Defaults: Lower limit: 0, Upper limit: 255	Set the upper and lower limit values for the chroma (saturation).

## Setting the Brightness Range to Extract (for Background Suppression Item Only)

The range in which to enhance the contrast and the brightness range to extract are set for the Background Suppression item. The Background Suppression item works as described below to suppress the background for the specified brightness range.

- Enhancing Contrast

The range of the input brightness that is within the specified brightness range (0 to 255) is converted to 255 levels to enhance the contrast.

- Background Suppression

Input values from 0 to the lower limit are converted to level 0 and input values between the upper limit and 255 are converted to level 255 to remove as the background any places that are not within the specified brightness range.

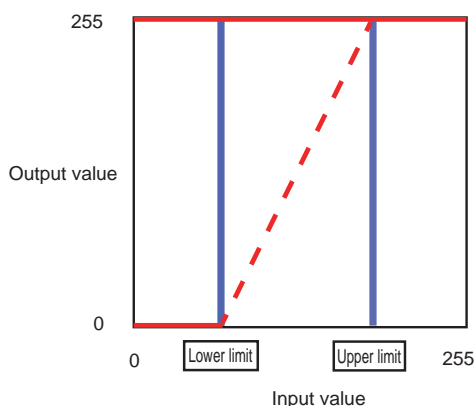

You can use either of the following methods to set the upper and lower limits of the brightness range to extract with the Background Suppression item.

• **Enhancing the Contrast of a Specific Area**

You specify the location on the image to enhance the contrast.

► **[Image] – [Image adjustment] – [Background Suppression] – [Modify]**

- 1 Press [◀] – [Suppression level] on the right of the display.
- 2 Drag on the image to specify the location to emphasize the contrast.  
The contrast in the specified range will be reset to between 0 and 255.
- 3 Press [OK].
- 4 Press [Back].



• **Extracting Only a Specified Range of Brightness**

You set the upper and lower limits of the brightness range to extract with the Background Suppression item.

► **[Image] – [Image adjustment] – [Background suppression] – [Modify]**

- 1 Press [◀] – [Suppression level] on the right of the display.
- 2 Press [◀] – [RGB setting] on the right of the display.
- 3 Select the method to use to specify the brightness range. (This setting applies to Sensors with Color Cameras only.)

• **Common RGB Settings**

Set the upper and lower limit values of the brightness range. The same limits will be used for all RGB colors.

• **Individual RGB Settings**

Set the upper and lower limit values of the brightness range for each RGB color. Press [R], [G], and [B] and set the upper and lower limits for each of them.

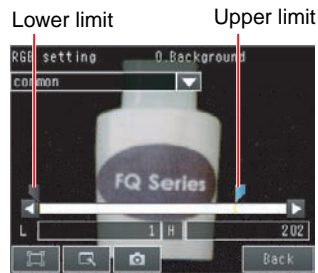

- 4 Set the upper and lower limit values of the brightness range. (for Sensors with Monochrome Cameras (or after a Color Gray Filter))



- 5 Press [Back].
- 6 Press [OK].
- 7 Press [Back].

Parameter	Setting	Description
Common (common RGB setting)	Range: 0 to 255 Defaults: Lower limit: 0, Upper limit: 255	Set the upper and lower limit values of the background suppression level. The same limits will be used for all RGB colors. The range from the specified lower to upper limits is converted to 0 to 255.
Individual (individual RGB settings)	Range: 0 to 255 Defaults: Lower limit: 0, Upper limit: 255	Set the upper and lower limit values of the background suppression level for each RGB color. The range from the specified lower to upper limits is converted to 0 to 255.
Brightness range (for Sensors with Monochrome Cameras)	Range: 0 to 255 Defaults: Lower limit: 0, Upper limit: 255	The specified range is converted to 0 to 255.

## Measurement Data That Can Be Used for External Outputs and Calculations

The following values can be used as measurement data and output to external devices via Ethernet or used in calculations. Measurement data can be specified for each filter item.

Expression text string	Data name	Description	Data range
JG	Judgement	This is the judgement result.	-2: No judgement (not measured), 0: Judgement is OK, -1: Judgement is NG

## Compensating for Position Offset (Position Compensation Items)

Use position compensation items if the position or orientation of the measurement object is not consistent. When you use a position compensation item, the offset between the reference position and the position of the object is calculated and the position of the measurement region is corrected before measurements are performed.

### Applicable Position Compensation Items

There are the following two types of position compensation items that vary in the method that is used to detect the object.

Type	Description
Model (model position compensation)	A search is made for a characteristic pattern to detect and correct the position. <ul style="list-style-type: none"> <li>• Shape Sear. pos. comp. (Shape Search Position Compensation)</li> <li>• Search position comp. (Search Position Compensation)</li> </ul>
Edge position comp. (edge position compensation)	The color distribution or density changes in the object are used to detect and correct the position. <ul style="list-style-type: none"> <li>• Edge position comp. (Edge Position Compensation)</li> <li>• 2Edge position comp. (Two-edge Position Compensation)</li> <li>• 2Edge midpoint comp. (Two-edge Midpoint Compensation)</li> <li>• Edge rot. pos. comp. (Edge Rotation Position Compensation)</li> </ul>



• Features of the Position Compensation Items

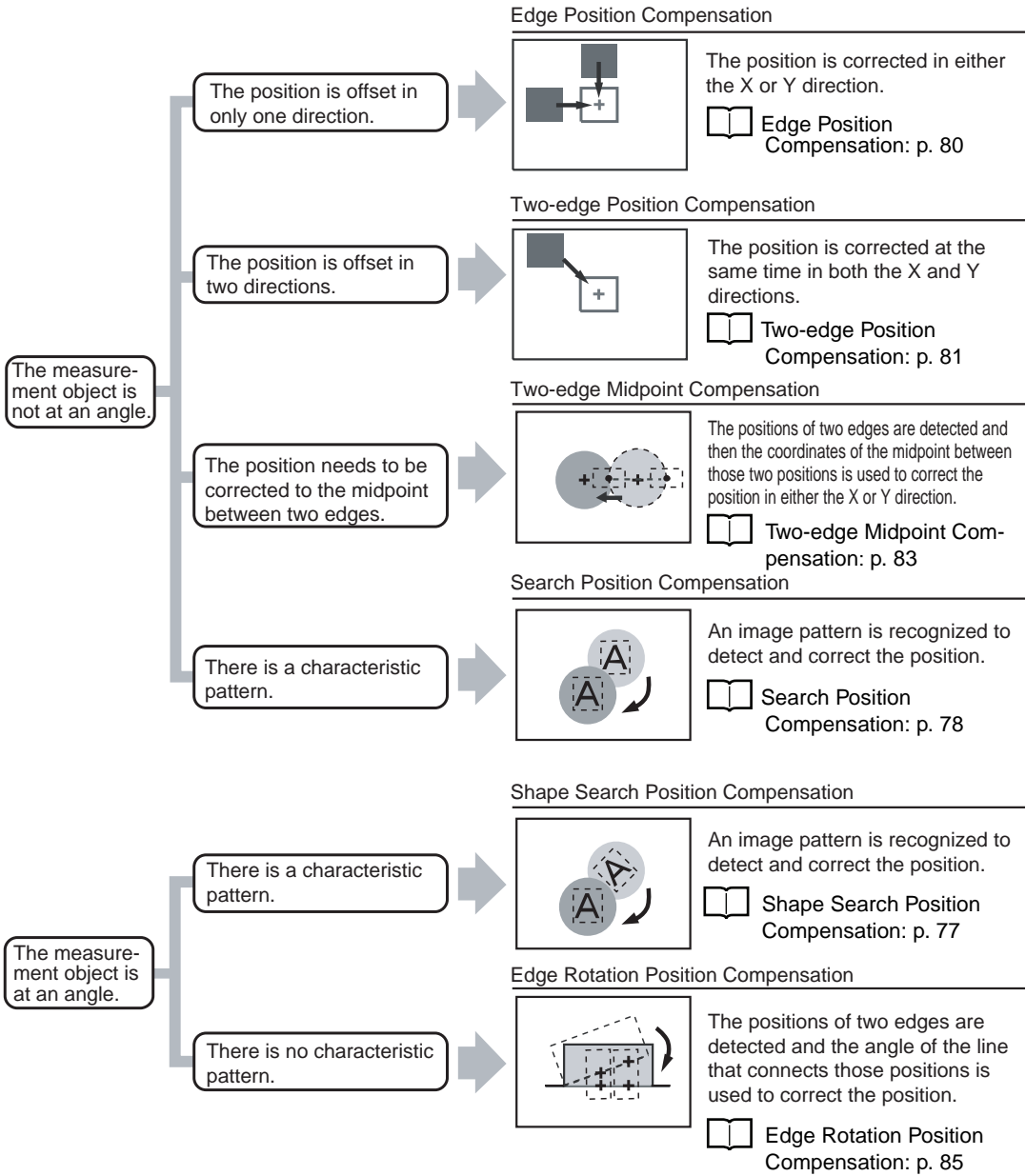

**Applying the Results of Position Compensation**

You can apply the results of position compensation either to the Camera image or to the previous image from before position compensation was applied.

If you apply the results of position compensation to the Camera image, only the position information from position compensation is applied to the image to be measured.

 Using Filter Items for Processing with Position Compensation Items: p. 76

• **Setting the Image for Position Compensation**

You can select the image to which to apply the results of position compensation processing. You can set the image for position compensation for each position compensation item.

► **[Image] – [Image adjustment] – (Position compensation item name) – [Modify]**

- 1 Press [Details] – [Scroll parameter]
- 2 Set the source image to [Camera] or [Prev.].

Parameter	Setting	Description
Source image	Camera (camera image)	The results of processing the position compensation item is applied to the image that is taken by the Camera. This setting is used when filter items or other position compensation items have been used specifically for the position compensation item.  Using Filter Items for Processing with Position Compensation Items: p. 76.
	Prev. (previous image) (default)	This setting is used when the processing results of the current position item are to be applied to the image that results from previous filter items or other position compensation items.

• **Using Filter Items for Processing with Position Compensation Items**

To more effectively perform position compensation, filter items can be used to create an image specifically for position compensation and then apply only the results of processing the position compensation to the image that will be measured. The processing order of filter and position compensation items and the settings of the source images are set up as shown below.

Processing order	Image processing item	Source image setting
1	0: Enhance edges (Edge Enhancement) (filter item)	Source image: Camera image Camera image (image for processing) → Processed image (results of processing)
2	1: Search position comp. (Search Position Compensation) (position compensation item)	Source image: Camera image Previous image (image for processing) → Camera image (results of processing)

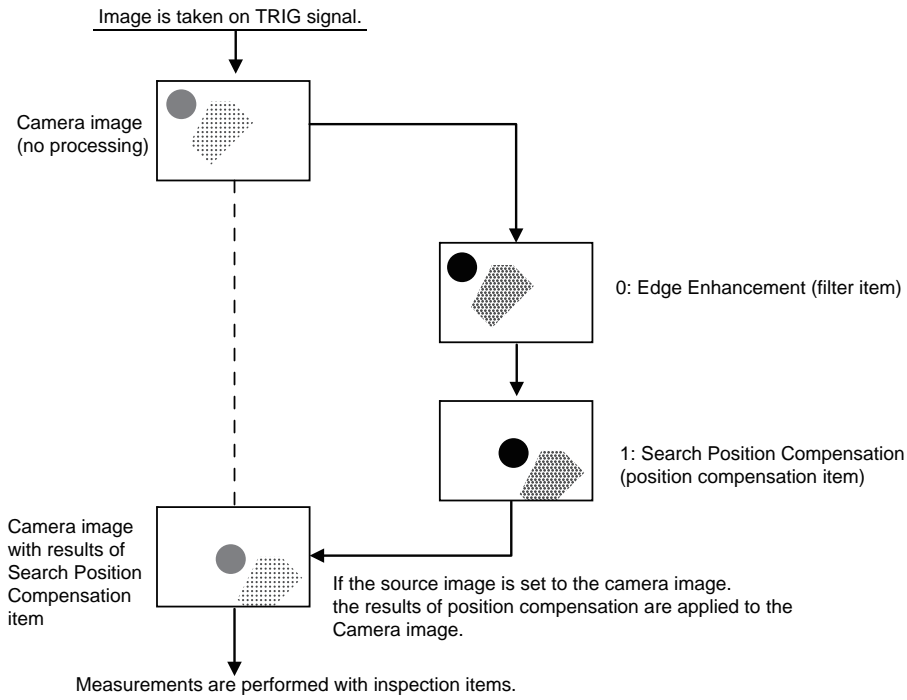

## Shape Search Position Compensation

With this position compensation item, an image pattern is registered in advance. When the registered image pattern is detected, the image is adjusted so that the image pattern is in the same position as when it was registered.

This position compensation item performs the same type of processing as the Search Position Compensation item, but it performs special processing for the shape of the image pattern.

Use this position compensation item to correct the position of a rotated image pattern.

### ► [Image] – [Image adjustment]

- 1 Press an unused number and then press [Add pos. comp.].
- 2 Press [Model] – [Shape Sear. pos. comp.]
- 3 Make any detailed settings as required for the position compensation processing.  
Refer to *Detailed Settings for Shape Search Position Compensation*, below.
- 4 Press [OK].
- 5 Press [Back].

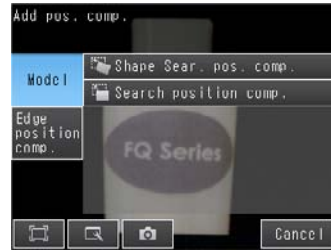

### • Detailed Settings for Shape Search Position Compensation

The settings for the Shape Search Position Compensation item are almost the same as those for the Search inspection item.

Only the [Sub-pixel] and the [Multi-point output] settings of the Search item are not included in the settings of the Search Position Compensation item. Make the settings for teaching and the judgement conditions in the same way as for the Search item. (☞ 4-4 Inspecting with the Search Inspection Item: p. 95) Also, the following settings are included only in the Shape Search Position Compensation Item.

#### • Rotation

This setting is used to enable rotating the image to correct.

### ► [Image] – [Image adjustment] – [Shape Sear. pos. comp.] – [Modify]

- 1 Press [Details] – [Model parameter]
- 2 Set [Rotation] to either [Yes] or [No].

Parameter	Setting	Description
Rotation	No (default) Yes	Specify whether to automatically create several patterns of rotated images and use them to measure the image. The processing time will increase if you enable rotation processing.

#### • Source Image

You can select the image to which to apply the results of position compensation processing.

☞ Applying the Results of Position Compensation: p. 75

#### • Interpolation

You can select the precision of position compensation.

If you select [Bilinear], the precision of position compensation will increase.

► [Image] – [Image adjustment] – [Shape Sear. pos. comp.] – [Modify]

- 1 Press [Details] – [Scroll parameter] – [Interpolation]
- 2 Set the interpolation to [Bilinear] or [None].

Parameter	Setting	Description
Interpolation	Bilinear (default)	Points are connected with lines to find approximations. This create smoother images.
	None	Position compensation is performed at the pixel level.

• **Measurement Data That Can Be Used for External Outputs and Calculations**

The following values can be used as measurement data and output to external devices via Ethernet or used in calculations.

Expression text string	Data name	Description	Data range
JG	Judgement	This is the judgement result.	-2: No judgement (not measured), 0: Judgement is OK, -1: Judgement is NG
DX	Scroll X	This is the amount of position compensation for the X coordinate.	-99,999.9999 to 99,999.9999
DY	Scroll Y	This is the amount of position compensation for the Y coordinate.	-99,999.9999 to 99,999.9999
DT	Scroll $\theta$	This is the amount of angular compensation, $\theta$ .	-180 to 180
X	Position X	This is the X coordinate of the position where the model was found.	-99,999.9999 to 99,999.9999
Y	Position Y	This is the Y coordinate of the position where the model was found.	-99,999.9999 to 99,999.9999
TH	Angle	This is the angle at which the model was found.	-180 to 180
SX	Reference X	This is the X coordinate of the position where the model was registered.	-99,999.9999 to 99,999.9999
SY	Reference Y	This is the Y coordinate of the position where the model was registered.	-99,999.9999 to 99,999.9999
ST	Reference angle	This is the angle when the model was registered.	-180 to 180
CR	Correlation	This is the correlation.	0 to 100

## Search Position Compensation

With this position compensation item, an image pattern is registered in advance. When the registered image pattern is detected, the image is adjusted so that the image pattern is in the same position as when it was registered.

This position compensation item performs the same type of processing as the Shape Search Position Compensation item, but it performs processing to detect differences in colors and patterns in addition to processing for image pattern shapes.

**Note**

To perform position compensation for a rotated image pattern, use the Shape Search Position Compensation item.

► [Image] – [Image adjustment]

- 1 Press an unused number and then press [Add pos. comp.].

- 2 Press [Model] – [Search position comp.]
- 3 Make any detailed settings as required for the position compensation processing.  
Refer to *Detailed Settings for Search Position Compensation*, below.
- 4 Press [OK].
- 5 Press [Back].

### • Detailed Settings for Search Position Compensation

The settings for the Search Position Compensation item are almost the same as those for the Search inspection item. Only the [Multi-point output] setting of the Search item is not included in the settings of the Search Position Compensation item. Make the settings for teaching and the judgement conditions in the same way as for the Search item. (  4-4 Inspecting with the Search Inspection Item: p. 95)

Also, the following settings are included only in the Search Position Compensation Item.

### • Source Image

You can select the image to which to apply the results of position compensation processing.

 Applying the Results of Position Compensation: p. 75

### • Interpolation

You can select the precision of position compensation.

If you select [Bilinear], the precision of position compensation will increase.

### ▶ [Image] – [Image adjustment] – [Search position comp.] – [Modify] – [Details] – [Scroll parameter] – [Interpolation]

The settings are the same as those for the Shape Search Position Compensation item.

 Interpolation: p. 77

### • Measurement Data That Can Be Used for External Outputs and Calculations

The following values can be used as measurement data and output to external devices via Ethernet or used in calculations.

Expression text string	Data name	Description	Data range
JG	Judgement	This is the judgement result.	-2: No judgement (not measured), 0: Judgement is OK, -1: Judgement is NG
DX	Scroll X	This is the amount of position compensation for the X coordinate.	-99,999.9999 to 99,999.9999
DY	Scroll Y	This is the amount of position compensation for the Y coordinate.	-99,999.9999 to 99,999.9999
X	Position X	This is the X coordinate of the position where the model was found.	-99,999.9999 to 99,999.9999
Y	Position Y	This is the Y coordinate of the position where the model was found.	-99,999.9999 to 99,999.9999
SX	Reference X	This is the X coordinate of the position where the model was registered.	-99,999.9999 to 99,999.9999
SY	Reference Y	This is the Y coordinate of the position where the model was registered.	-99,999.9999 to 99,999.9999
CR	Correlation	This is the correlation.	0 to 100

## Edge Position Compensation

This position compensation item detects an edge in the set direction.

If the specified color is detected (or the specified density is detected for a Sensor with a Monochrome Camera), it is recognized as an edge.

When an edge is recognized, the image is adjusted so that the edge appears at the position it was in when it was registered.

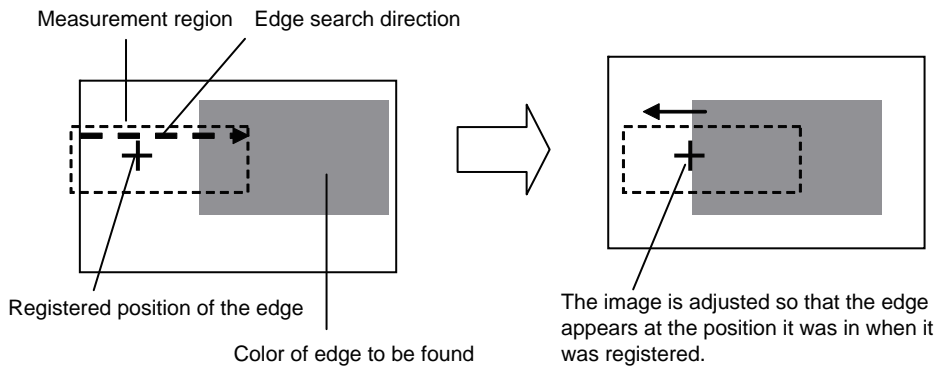

### ► [Image] – [Image adjustment]

- 1 Press an unused number and then press [Add pos. comp.].
- 2 Press [Edge] – [Edge position comp.].
- 3 Make any detailed settings as required for the position compensation processing.  
Refer to *Detailed Settings for Edge Position Compensation*, below.
- 4 Press [OK].
- 5 Press [Back].

### • Detailed Settings for Edge Position Compensation

The settings for the Edge Position Compensation item are almost the same as those for the Edge Position inspection item.

Make the settings for teaching and the judgement conditions in the same way as for the Edge Position inspection item. ( 4-7 Inspecting with the Edge Position Inspection Item: p. 120)

However, the following settings are included only in the Edge Position Compensation Item.

### • Source Image

You can select the image to which to apply the results of position compensation processing.

Applying the Results of Position Compensation: p. 75

### • Interpolation

You can select the precision of position compensation.

If you select [Bilinear], the precision of position compensation will increase.

### ► [Image] – [Image adjustment] – [Edge position comp.] – [Modify] – [Details] - [Scroll parameter] – [Interpolation]

The settings are the same as those for the Shape Search Position Compensation item.

Interpolation: p. 77

## • Measurement Data That Can Be Used for External Outputs and Calculations

The following values can be used as measurement data and output to external devices via Ethernet or used in calculations.

Expression text string	Data name	Description	Data range
JG	Judgement	This is the judgement result.	-2: No judgement (not measured), 0: Judgement is OK, -1: Judgement is NG
DX	Scroll X	This is the amount of position compensation for the X coordinate.	-99,999.9999 to 99,999.9999
DY	Scroll Y	This is the amount of position compensation for the Y coordinate.	-99,999.9999 to 99,999.9999
X	Position X (edge position X)	This is the X coordinate of the measured edge position.	-99,999.9999 to 99,999.9999
Y	Position Y (edge position Y)	This is the Y coordinate of the measured edge position.	-99,999.9999 to 99,999.9999
SX	Reference X	This is the X coordinate of the edge position when it was registered.	-99,999.9999 to 99,999.9999
SY	Reference Y	This is the Y coordinate of the edge position when it was registered.	-99,999.9999 to 99,999.9999

## Two-edge Position Compensation

This position compensation item detects edges in two directions.

If the specified color is detected (or the specified density is detected for a Sensor with a Monochrome Camera), it is recognized as an edge.

When an edge is recognized, the image is adjusted so that the edge appears at the position it was in when it was registered.

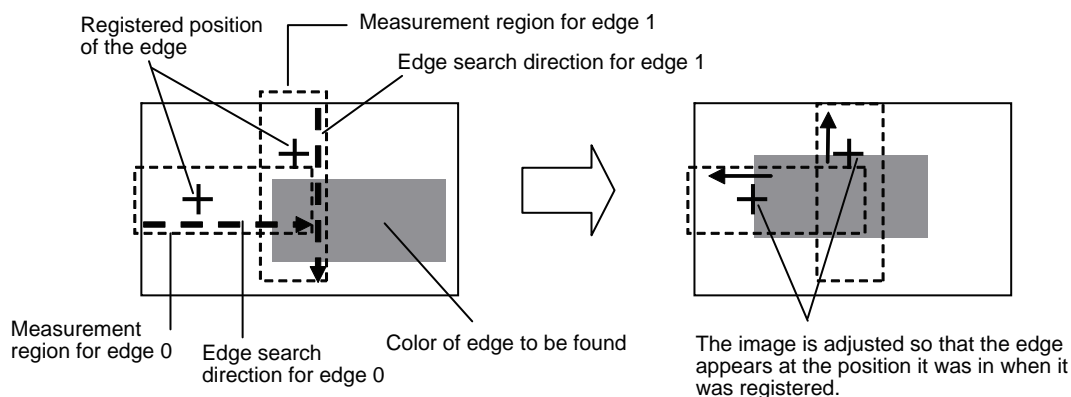

### ► [Image] – [Image adjustment]

- 1** Press an unused number and then press **[Add pos. comp.]**.
- 2** Press **[Edge]** – **[2Edge position comp.]**
- 3** Make any detailed settings as required for the position compensation processing.  
Refer to Detailed Settings for Search Position Compensation, below.
- 4** Press **[OK]**.
- 5** Press **[Back]**.

### • Detailed Settings for Two-edge Position Compensation

The settings for the Two-edge Position Compensation item are almost the same as those for the Edge Position inspection item.

Make the settings in the same way as for the Edge Position inspection item. (  4-7 Inspecting with the Edge Position Inspection Item: p. 120)

However, the following settings are included only in the Edge Position Compensation Item.

### • Teaching

Set the measurement regions and measurement directions for both edge 0 and edge 1.

#### ▶ [Image] – [Image adjustment] – [2Edge position comp.] – [Modify] – [Basic]

- 1 Press [Teach].
- 2 Place the object that is to be used as the measurement reference in front of the camera.
- 3 Move the rectangle to the location to be measured, and then press [OK].

This concludes setting the measurement region and edge search direction for edge 0.

Next, go to step 4 to set the measurement region and edge search direction for edge 1.

- 4 Press [◀] – [Edge1 region] on the right of the display, move the rectangle to the location to be measured, and then press [OK].
- 5 Press [TEACH] on the lower right of the display. The basic settings will be registered when teaching has been completed.
- 6 Press [Back] to end teaching.

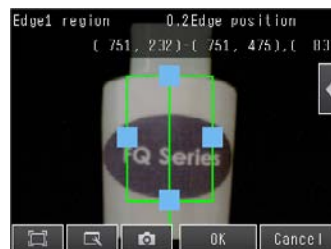
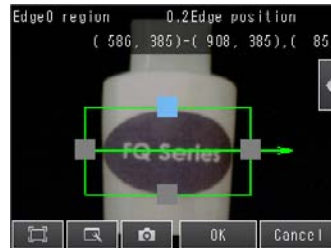

### • Source Image

You can select the image to which to apply the results of position compensation processing.

 Applying the Results of Position Compensation: p. 75

### • Interpolation

You can select the precision of position compensation.

If you select [Bilinear], the precision of position compensation will increase.

#### ▶ [Image] – [Image adjustment] – [2Edge position comp.] – [Modify] – [Details] – [Interpolation]

The settings are the same as those for the Shape Search Position Compensation item.

 Interpolation: p. 77

### • Measurement Data That Can Be Used for External Outputs and Calculations

The following values can be used as measurement data and output to external devices via Ethernet or used in calculations.



Expression text string	Data name	Description	Data range
JG	Judgement	This is the judgement result.	-2: No judgement (not measured), 0: Judgement is OK, -1: Judgement is NG
DX	Scroll X	This is the amount of position compensation for the X coordinate.	-99,999.9999 to 99,999.9999
DY	Scroll Y	This is the amount of position compensation for the Y coordinate.	-99,999.9999 to 99,999.9999
X0	Edge 0 position X	This is the X coordinate of the measured edge 0 position.	-99,999.9999 to 99,999.9999
Y0	Edge 0 position Y	This is the Y coordinate of the measured edge 0 position.	-99,999.9999 to 99,999.9999
X1	Edge 1 position X	This is the X coordinate of the measured edge 1 position.	-99,999.9999 to 99,999.9999
Y1	Edge 1 position Y	This is the Y coordinate of the measured edge 1 position.	-99,999.9999 to 99,999.9999
SX0	Edge0 ref. position X (edge 0 reference position X)	This is the X coordinate of the edge 0 position when it was registered.	-99,999.9999 to 99,999.9999
SY0	Edge0 ref. position Y (edge 0 reference position Y)	This is the Y coordinate of the edge 0 position when it was registered.	-99,999.9999 to 99,999.9999
SX1	Edge1 ref. position X (edge 1 reference position X)	This is the X coordinate of the edge 1 position when it was registered.	-99,999.9999 to 99,999.9999
SY1	Edge1 ref. position Y (edge 1 reference position Y)	This is the Y coordinate of the edge 1 position when it was registered.	-99,999.9999 to 99,999.9999

## Two-edge Midpoint Compensation

This position compensation item detects edges in two directions.

If the specified color is detected (or the specified density is detected for a Sensor with a Monochrome Camera), it is recognized as an edge. Two edge positions are detected.

The image is adjusted so that the coordinates of the midpoint position of a line that connects the two detected edge positions matches the position when the edges were registered.

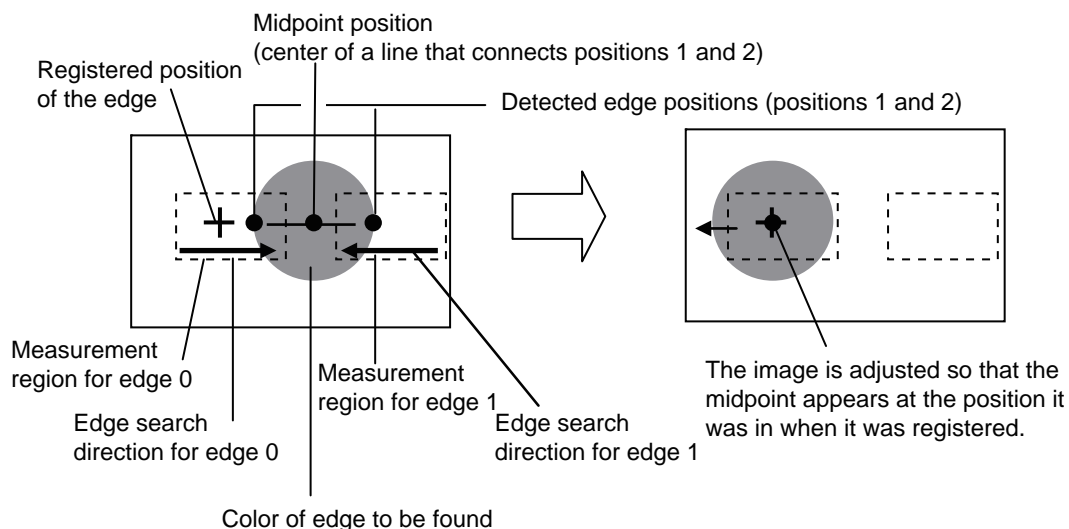

### ► [Image] – [Image adjustment]

- 1 Press an unused number and then press [Add pos. comp.].

- 2 Press [Edge] – [2Edge midpoint comp.]
- 3 Make any detailed settings as required for the position compensation processing.  
Refer to *Detailed Settings for Two-edge Midpoint Compensation*, below.
- 4 Press [OK].
- 5 Press [Back].

#### • Detailed Settings for Two-edge Midpoint Compensation

The settings for the Two-edge Midpoint Compensation item are almost the same as those for the Edge Position inspection item.

Make the settings in the same way as for the Edge Position inspection item. (  4-7 Inspecting with the Edge Position Inspection Item: p. 120)

However, the following settings are included only in the Edge Position Compensation Item.

#### • Teaching

Set the measurement regions and measurement directions for both edge 0 and edge 1.

#### ▶ [Image] – [Image adjustment] – [2Edge midpoint comp.] – [Modify] – [Basic] – [Teach]

The settings are the same as those for the Two-edge Position Compensation item.

 Teaching: p. 82

#### • Source Image

You can select the image to which to apply the results of position compensation processing.

 Applying the Results of Position Compensation: p. 75

#### • Interpolation

You can select the precision of position compensation.

If you select [Bilinear], the precision of position compensation will increase.

#### ▶ [Image] – [Image adjustment] – [2ed. midp. comp.] – [Modify] – [Details] – [Scroll parameter] – [Interpolation]

The settings are the same as those for the Shape Search Position Compensation item.

 Interpolation: p. 77

#### • Measurement Data That Can Be Used for External Outputs and Calculations

The following values can be used as measurement data and output to external devices via Ethernet or used in calculations.

Expression text string	Data name	Description	Data range
JG	Judgement	This is the judgement result.	-2: No judgement (not measured), 0: Judgement is OK, -1: Judgement is NG
DX	Scroll X	This is the amount of position compensation for the X coordinate.	-99,999.9999 to 99,999.9999
DY	Scroll Y	This is the amount of position compensation for the Y coordinate.	-99,999.9999 to 99,999.9999
X0	Edge 0 position X	This is the X coordinate of the measured edge 0 position.	-99,999.9999 to 99,999.9999

Expression text string	Data name	Description	Data range
Y0	Edge 0 position Y	This is the Y coordinate of the measured edge 0 position.	-99,999.9999 to 99,999.9999
X1	Edge 1 position X	This is the X coordinate of the measured edge 1 position.	-99,999.9999 to 99,999.9999
Y1	Edge 1 position Y	This is the Y coordinate of the measured edge 1 position.	-99,999.9999 to 99,999.9999
MX	Midpoint X	This is the X coordinate of the measured edge midpoint position.	-99,999.9999 to 99,999.9999
MY	Midpoint Y	This is the Y coordinate of the measured edge midpoint position.	-99,999.9999 to 99,999.9999
SX0	Edge0 ref. position X (edge 0 reference position X)	This is the X coordinate of the edge 0 position when it was registered.	-99,999.9999 to 99,999.9999
SY0	Edge0 ref. position Y (edge 0 reference position Y)	This is the Y coordinate of the edge 0 position when it was registered.	-99,999.9999 to 99,999.9999
SX1	Edge1 ref. position X (edge 1 reference position X)	This is the X coordinate of the edge 1 position when it was registered.	-99,999.9999 to 99,999.9999
SY1	Edge1 ref. position Y (edge 1 reference position Y)	This is the Y coordinate of the edge 1 position when it was registered.	-99,999.9999 to 99,999.9999
SMX	Ref. Midpoint X (reference midpoint X)	This is the X coordinate of the midpoint of the two edges when they were registered.	-9,999.9999 to 99,999.9999
SMY	Ref. Midpoint Y (reference midpoint Y)	This is the Y coordinate of the midpoint of the two edges when they were registered.	-9,999.9999 to 99,999.9999

## Edge Rotation Position Compensation

This position compensation item detects an edge in two directions.

If the specified color is detected (or the specified density is detected for a Sensor with a Monochrome Camera), it is recognized as an edge. Two edge positions are detected.

The image is adjusted so that the two edge positions match the positions when the edge positions were registered.

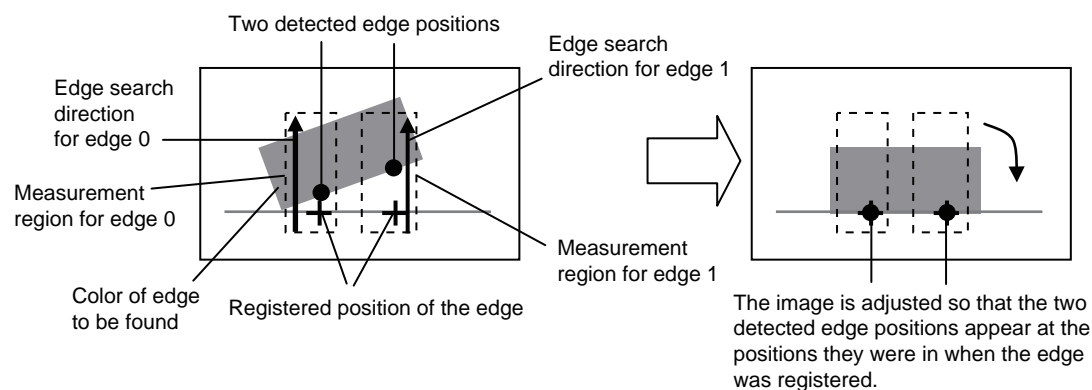

### ► [Image] – [Image adjustment]

- 1** Press an unused number and then press **[Add pos. comp.]**.
- 2** Press **[Edge] – [Edge rot. pos. Comp.]**
- 3** Make any detailed settings as required for the position compensation processing.  
Refer to *Detailed Settings for Edge Rotation Position Compensation*, below.

- 4 Press [OK].
- 5 Press [Back].

• **Detailed Settings for Edge Rotation Position Compensation**

The settings for the Edge Rotation Position Compensation item are almost the same as those for the Edge Position inspection item.

Make the settings in the same way as for the Edge Position inspection item. (  4-7 Inspecting with the Edge Position Inspection Item: p. 120)

However, the following settings are included only in the Edge Position Compensation Item.

• **Teaching**

- Measurement Regions and Measurement Directions

Set the measurement regions and measurement directions for both edge 0 and edge 1.

▶ **[Image] – [Image adjustment] – [Edge rot. pos. Comp.] – [Modify] – [Basic] – [Teach]**

The settings are the same as those for the Two-edge Position Compensation item.

 Teaching: p. 82

• **Reference Angle**

Set the reference angle.

Press [] – [Edit Ref. angle] on the right of the display and set the angle.

• **Source Image**

You can select the image to which to apply the results of position compensation processing.

 Applying the Results of Position Compensation: p. 75

• **Interpolation**

You can select the precision of position compensation.

If you select [Bilinear], the precision of position compensation will increase.

▶ **[Image] – [Image adjustment] – [2Edge position comp.] – [Modify] – [Details] – [Interpolation]**

The settings are the same as those for the Shape Search Position Compensation item.

 Interpolation: p. 77

• **Measurement Data That Can Be Used for External Outputs and Calculations**

The following values can be used as measurement data and output to external devices via Ethernet or used in calculations.

Expression text string	Data name	Description	Data range
JG	Judgement	This is the judgement result.	-2: No judgement (not measured), 0: Judgement is OK, -1: Judgement is NG
DT	Scroll $\theta$	This is the amount of position compensation.	-180 to 180
X0	Edge 0 position X	This is the X coordinate of the measured edge 0 position.	-99,999.9999 to 99,999.9999

Expression text string	Data name	Description	Data range
Y0	Edge 0 position Y	This is the Y coordinate of the measured edge 0 position.	-99,999.9999 to 99,999.9999
X1	Edge 1 position X	This is the X coordinate of the measured edge 1 position.	-99,999.9999 to 99,999.9999
Y1	Edge 1 position Y	This is the Y coordinate of the measured edge 1 position.	-99,999.9999 to 99,999.9999
TH	Angle (edge angle)	This is the measured angle.	-180 to 180
SX0	Edg0 ref. pos. (edge 0 reference position X)	This is the X coordinate of the edge 0 position when it was registered.	-99,999.9999 to 99,999.9999
SY0	Edg0 ref. pos. Y (edge 0 reference position Y)	This is the Y coordinate of the edge 0 position when it was registered.	-99,999.9999 to 99,999.9999
SX1	Edg1 ref. pos. X (edge 1 reference position X)	This is the X coordinate of the edge 1 position when it was registered.	-99,999.9999 to 99,999.9999
SY1	Edg1 ref. pos. Y (edge 1 reference position Y)	This is the Y coordinate of the edge 1 position when it was registered.	-99,999.9999 to 99,999.9999
STH	Reference angle	This is the angle when the edge was registered.	-180 to 180

MEMO





# Setting Up Inspections

---



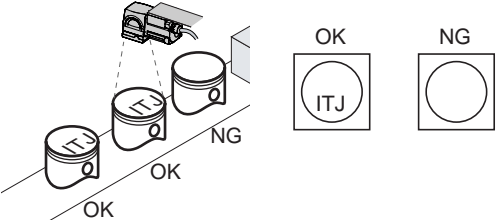

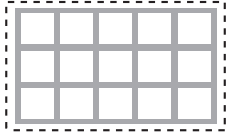
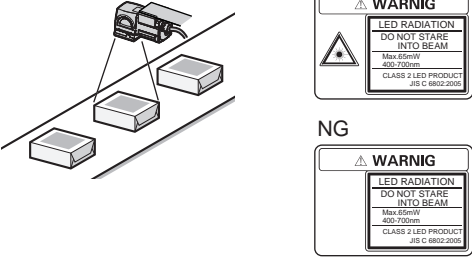

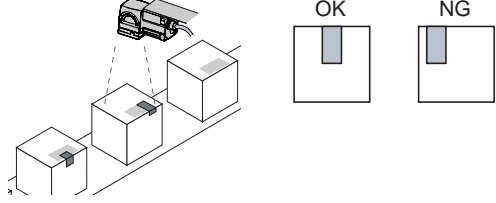
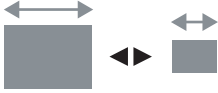
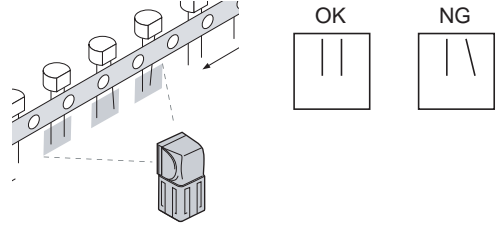

4-1 Inspection Item Selection Guide . . . . .	90
4-2 Setup Procedure for Inspection Items . . . . .	92
4-3 Configuring Inspection Items . . . . .	93
4-4 Inspecting with the Search Inspection Item . . . . .	95
4-5 Inspecting with the Shape Search II Inspection Item . . . . .	105
4-6 Inspecting with the Sensitive Search Inspection Item . . . . .	113
4-7 Inspecting with the Edge Position Inspection Item . . . . .	120
4-8 Inspecting with the Edge Width Inspection Item. . . . .	127
4-9 Inspecting with the Edge Pitch Inspection Item . . . . .	131
4-10 Inspecting with Color Data Inspection Item. . . . .	136
4-11 Inspecting with the Area Inspection Item . . . . .	140
4-12 Inspecting with the Labeling Inspection Item . . . . .	146
4-13 Calculations and Judgements Using Inspection Item Data . . . . .	155

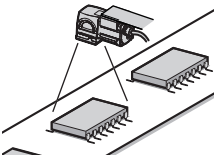
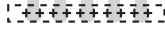
# 4-1 Inspection Item Selection Guide

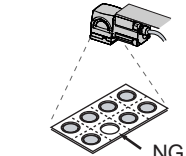
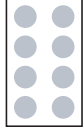
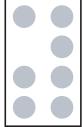
The FQ2 Vision Sensor uses inspection items to judge measurement objects. There are eight different measurement objects. Select the best inspection items for the characteristics of the measurement object that are being judged.

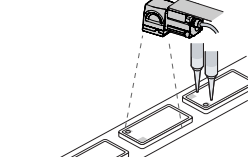
Inspection	Example	Inspection items used	Reference
Judging according to shapes 	Judging if there is a mark 	Search or Shape Search II	p. 95 p. 105
Detecting positions with patterns 	Measurement objects of the same color and pattern can be detected.	Search	p. 95
Dividing the measurement area and judging according to shapes for each division 	Judging minute differences in printed labels 	Sensitive Search	p. 113
Judging according to positions 	Measuring the position offset of a seal 	Edge Position	p. 120
Judging according to widths 	Measuring the width between lead wires 	Edge Width	p. 127

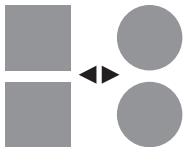
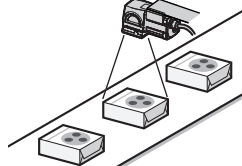

Inspection	Example	Inspection items used	Reference
<p>Judging according to the features of parts of a shape</p> 	<p>Judging the number of pins</p>  <p>OK</p>  <p>NG</p> 	Edge Pitch	p. 105
<p>Judging according to colors</p> 	<p>Detecting parts</p>  <p>OK</p>  <p>NG</p> 	Color Data	p. 136
<p>Judging according to sizes</p> 	<p>Judging if there is silver paste</p>  <p>OK</p>  <p>NG</p> 	Area	p. 140
<p>Judging according to shapes and quantities</p> 	<p>Judging the number of labels</p>  <p>OK</p>  <p>NG</p> 	Labeling	p. 146

## 4-2 Setup Procedure for Inspection Items

The basic steps for setting up inspection items are shown below.

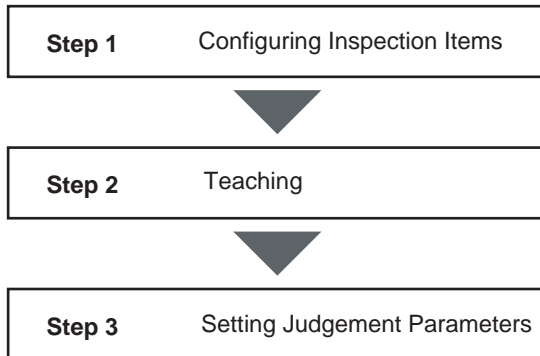

If measurements are unstable

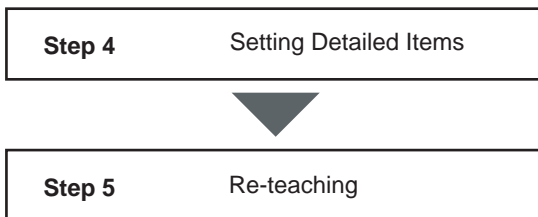

**Note**

---

Only one inspection item can be used with the FQ2-S1□.  
Up to 32 inspection items can be combined and used with the FQ2-S2□ or FQ2-S3□.

---

# 4-3 Configuring Inspection Items

## Adding New Inspection Items

1 Press [Inspect] – [Inspection].

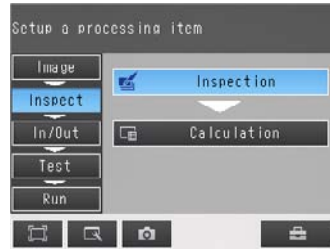

2 Press an unused inspection item number.

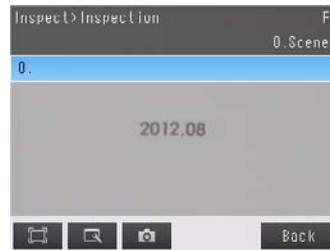

3 Press [Add item.] on the menu.

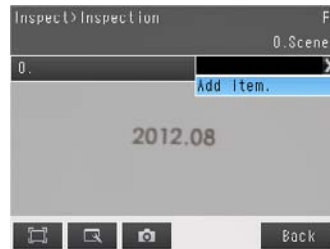

4 Select an inspection item, such as [Search].

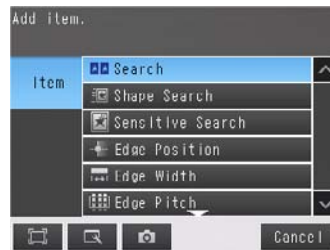

When registering multiple inspection items, press the inspection item number after 1,--- and set it in the same way.

**Note**

If more than six inspection items are set, drag the  icon at the bottom of the menu upward to display the next inspection item numbers.

## Modifying Existing Inspection Items

- 1 Press the number of the inspection item to be set.



- 2 Press [Modify] on the menu.

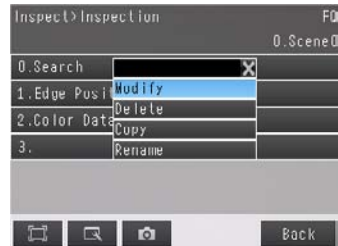

## Deleting Inspection Items

- 1 Press the number of the inspection item to be deleted.
- 2 Press [Delete] on the menu.

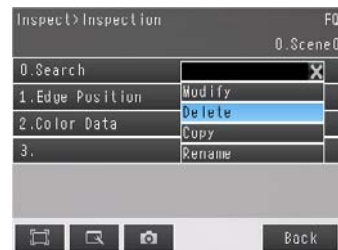

### Note

Executing Similar Measurements in Different Places

→ Copy an inspection item that is already registered: [Copy].

→ Change the name of an inspection item: [Rename].

# 4-4 Inspecting with the Search Inspection Item

## Search Inspection Item

This inspection item is used to perform inspections for shapes or for presence. The image pattern that is to be measured is registered in advance and measurements are performed to see if the pattern is present or if the shape is different.

The image pattern that is registered in advance is called the model. The degree to which the image matches the model is called the correlation.

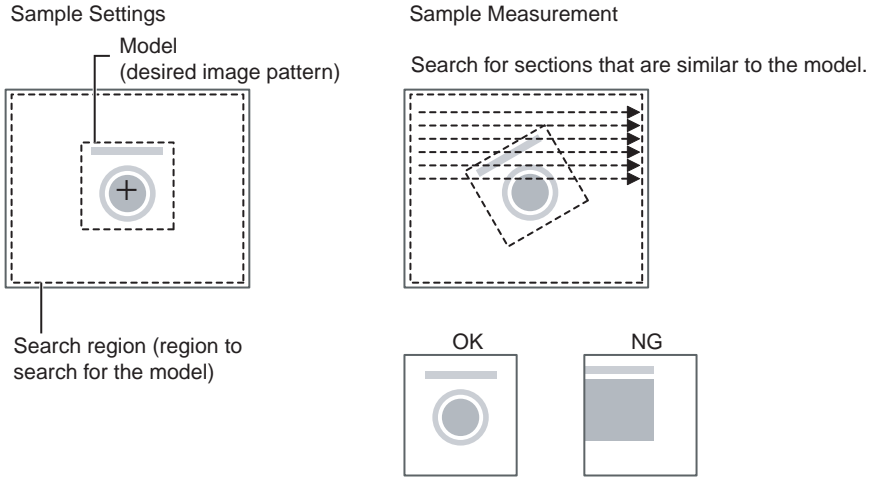

## Setup Procedure for the Search Inspection Item

### Step 1 Selecting the Inspection Item

#### ► [Inspect] – [Inspection]

- 1 Press an unused inspection item number and press [Add item.].
- 2 Press [Search].

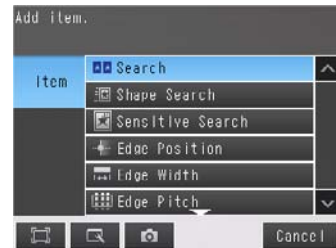

Registering inspection items: p. 93

#### Note

Drag the arrow at the bottom of the menu upward to display all of the inspection items.

## Step 2 Teaching

Teaching means to store the region and partial image as reference data for the measurement.

### ► [Inspect] – [Inspection] – [Add item.] – [Search] – [Settings] Tab Page

- 1 Press [Teach].
- 2 Place the object that is to be used as the measurement reference in front of the camera.
- 3 Move the rectangle to the location to be measured.
- 4 Press [OK].
- 5 Press [TEACH] on the lower right of the display.  
The basic settings will be registered when teaching has been completed.
- 6 Press [Back] to end teaching.

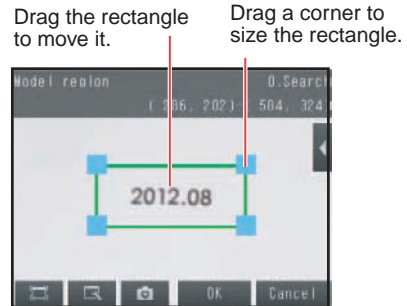

The following data is stored as the measurement reference.

Item	Parameter	Description
Reference data	Model image	This is the partial image that is stored as the reference.
	Reference position X	These are coordinates of the model image that are stored as reference.
	Reference position Y	

## Step 3 Adjusting Judgement Parameters

### ► [Inspect] – [Inspection] – [Add item.] – [Search] – [Settings] Tab Page

- 1 Press [Judgement].
- 2 Press each parameter and set the range that is to be judged as OK. Set the range for each of the following parameters.  
Continuous measurements will be performed for the images that are taken.

**Note**

You can change the parameters for judgement conditions on the Display Settings Display. Press [◀] – [Display setting] on the right of the display to switch to the Display Settings Display.

- 3 Press [OK] to accept the value.
- 4 Press [Back] to end making the setting.

If more than one result was detected, you can switch to a display for each result. (Multi-point output must be enabled.)

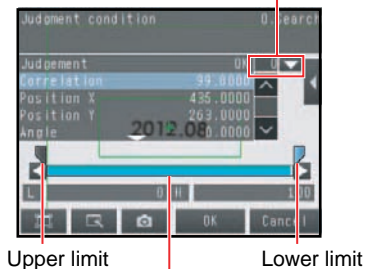

Blue for OK. Red for NG.

Parameter	Setting	Description
Correlation	Range: 0 to 100 Defaults: Lower limit: 60, Upper limit: 100	Adjust the upper and lower limits of the correlation for an OK judgement.
Position X	Range: -99,999.9999 to 99,999.9999 Defaults: Lower limit: -99,999.9999, Upper limit: 99,999.9999	Adjust the upper and lower limits of measurement position X for an OK judgement.
Position Y	Range: -99,999.9999 to 99,999.9999 Defaults: Lower limit: -99,999.9999, Upper limit: 99,999.9999	Adjust the upper and lower limits of measurement position Y for an OK judgement.
Angle	Range: -180 to 180 Defaults: Lower limit: -180, Upper limit: 180	Adjust the upper and lower limits of angle for an OK judgement.
Count	Range: 0 to 32 Defaults: Lower limit: 0, Upper limit: 32	Adjust the upper and lower limits of the detection count for an OK judgement.

**Note**

- You can change the output form for each measurement value to one of the following settings.  
 Press [◀] – [Result type] on the right of the display.  
 Absolute value (default): The measured coordinates are output.  
 Relative value: The difference from the reference position is output as coordinates.

## Increasing Measurement Position Accuracy

You can increase the accuracy of measurement positioning.

You can calculate down to four decimal places.

▶ [Inspect] – [Inspection] – [Search] – [Modify] – [Details] Tab Page – [Meas. Parameter]

1 Press [Sub-pixel] and select [Yes].

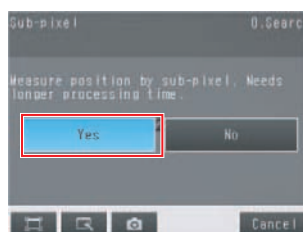

## Obtaining Multiple Results Simultaneously

You can detect all items that satisfy the extraction conditions.

Judgement is performed for all detected results.

▶ [Inspect] – [Inspection] – [Search] – [Modify] – [Details] Tab Page – [Meas. Parameter]

- Press [Multi-point output] and select [Yes].
- Press [Sorting method] and select the conditions by which to sort the detected results.

You can output the results in the sort order that you selected.

**Note**

You can specify the actual output conditions and count for outputting multiple results.

Selecting the results to output: p. 98

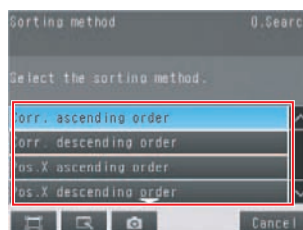

Selection item	Setting	Description
Sorting method	Corr. ascending order (ascending order of correlation value)	Sorts the results in order from the smallest correlation to the largest.
	Corr. descending order (descending order of correlation value)	Sorts the results in order from the largest correlation to the smallest.
	Pos.X ascending order (ascending order of position X)	Sorts the results in order from the smallest measurement X position to the largest.
	Pos.X descending order (descending order of position X)	Sorts the results in order from the largest measurement X position to the smallest.
	Pos.Y ascending order (ascending order of position Y)	Sorts the results in order from the smallest measurement Y position to the largest.
	Pos.Y descending order (descending order of position Y)	Sorts the results in order from the largest measurement Y position to the smallest.

## Select the Results to Output

You can use multiple conditions to determine which results to output from all the objects detected with a correlation at the candidate level or higher.

Only the results that meet all the specified conditions are output.

► **[Inspect] – [Inspection] – [Search] – [Modify] – [Details] Tab Page – [Meas. Parameter]**

- 1 Press **[Extraction condition]** and adjust the candidate level so that only objects higher than a certain correlation are detected.
- 2 If **[Multi-point output]** is set to **[Yes]**, you can specify the output conditions for more than one result. (**Extraction X/Y and Detection count**)

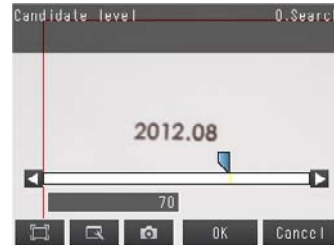

Extraction condition	Range	Description
Candidate level	0 to 100	Outputs only objects with a correlation that is higher than the specified candidate level.
Extraction X	-99999.9999 to 99999.9999	Results are output only for objects with a measured X coordinate that is within this range.
Extraction Y	-99999.9999 to 99999.9999	Results are output only for objects with a measured Y coordinate that is within this range.
Detection count	1 to 32	Sets the maximum number of detection results to output.

### Note

The processing time changes if you change the candidate level.

## Reflect in Total Judgement

You can specify whether to reflect the judgement results of an inspection item in the overall judgement. (The default is to reflect them.)

► **[Inspect] – [Inspection] – [Add item.] – [Search] – [Details] Tab Page – [Output parameter]**



## Unstable Search Results

### Inclined Measurement Objects

Adjust the [Angle range] parameter to increase the range in which a search is made for the model. The Search inspection item judges whether an image is OK or NG according to the correlation with a previously registered image pattern. For this reason, if the object is at an angle, the correlation is reduced and the image may be judged as NG. To achieve an OK judgement for the same image pattern even when the object is at an angle, the rotation range must be widened.

► [Inspect] – [Inspection] – [Search] – [Modify] – [Details] Tab Page – [Model parameter]

- 1 Set [Rotation] to [Yes].
- 2 Press [Angle range] and set the following range.

Parameter	Setting	Description
Angle range	Range: –180 to 180 Default: Lower limit: –180, Upper limit: 180	A search is performed within the set angle range. The larger the angle range, the longer the processing time.  <b>Important</b> If you change the angle range, perform teaching again.   p. 96

### Correlation Is Inconsistent Due to Low Contrast

Adjust the brightness to improve the contrast of the mark.

 Adjust the brightness: p. 61

### Correlation Is Inconsistent Due to Variations in the Measurement Object

Inconsistent portions can be masked so that they are omitted from matching.

 Model masking: p. 101

## Increasing Processing Speed

The following two methods can be used to reduce processing time.

- **Reduce the range in which a search is performed for the model.**

 Changing the measurement region: p. 102

- **Reduce the angle range setting.**

Adjust the [Angle range] parameter to reduce the range in which a search for the model is performed.

 Setting the angle range: p. 99

## Editing the Model and Measurement Regions

This section describes how to edit the following regions.

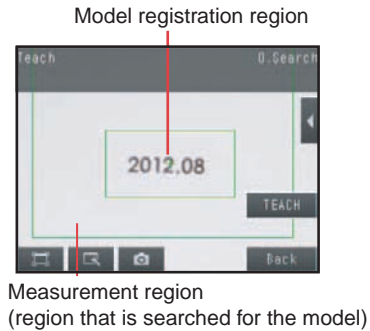

### Important

If the model region is changed, perform teaching again.

 p. 96

## Changing the Model Registration Region to a Shape Other Than a Rectangle

One rectangular region is registered as the default model registration region.

Other than rectangles, circles and polygons can be set as the model registration regions.

► **[Inspect] – [Inspection] – [Search] – [Modify] – [Settings] Tab Page – [Teach] – [◀] – [Model region]**

- 1 Press [◀] – [Model region].**
- 2 Press [◀] – [Delete] in the model registration editing display.**  
The rectangle will be deleted.

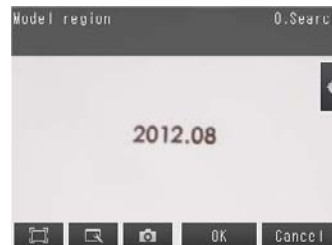

- 3 Press [Yes].**
- 4 Press [Add] in [◀].**
- 5 Press the shape of the region that you want to use.**
- 6 Draw the region.**
- 7 Press [OK].**

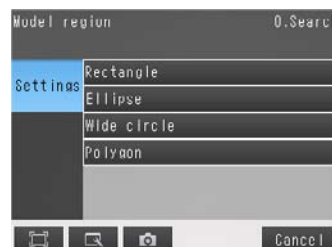

### Note

Up to 8 shapes can be combined to create a region for one model.

## Masking Parts of the Model

The model registration region can be formed freely by combining enabled and disabled regions.

Example:

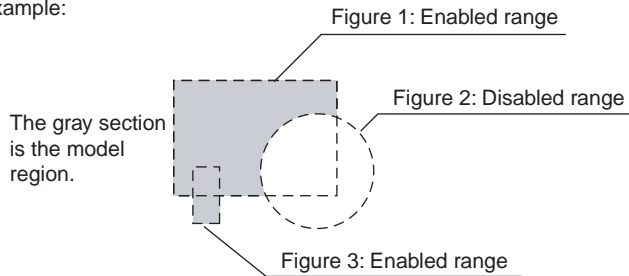

### ► [Inspect] – [Inspection] – [Search] – [Modify] – [Settings] Tab Page – [Teach] – [◀] – [Model region]

**1** Draw the figure according to the section that you want to mask.

p. 100

**2** While the figure to be masked is selected, press [◀] on the right of the display and then press [OR/NOT]

The selected area will be removed from the model. Every time you press [OR/NOT], the area will switch between being enabled and disabled.

OR: Enabled range  
NOT: Disabled range

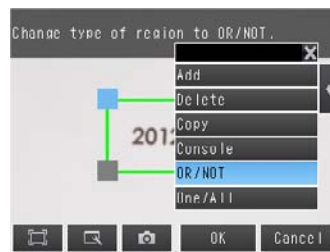

## Fine-tuning the Position of the Region

This section describes the console which is useful to fine-tune the position of the measurement region or the model registration region in 1-pixel increments.

### ► [Inspect] – [Inspection] – [Search] – [Modify] – [Settings] Tab Page – [Teach] – [◀] – [Model region]

**1** Press [◀] – [Console] on the right side of the display where you draw the region. The console will appear.

**2** To adjust the position of the figure, press within the frame. To adjust the size of the figure, press a corner of the figure.

**3** Use the cross-key to align the figure with the search object.

The position of the figure can be adjusted by pressing the cross-key. Pressing it once will change the coordinate values by one pixel.

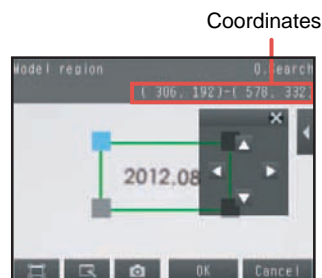

## Changing the Measurement Region

The region within which the model is searched can be changed. In the default settings, the whole display is set as the measurement region.

### ► [Inspect] – [Inspection] – [Search] – [Modify] – [Settings] Tab Page – [Teach]

**1** Press [◀] – [Insp. region] on the right of the display.  
The [Insp. region] Display will appear.

**2** Adjust the size and position of the measurement region.

- Change the size.  
Press the frame at one corner.  
The processing time can be shortened by making the region smaller.
- Change the position.  
Drag the figure to move it.

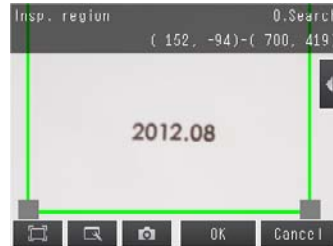

## Changing Output Coordinate Positions

You can specify which part of the model to detect as coordinates during inspections. Normally, the center position of the registered model is used as the detection point.

### ► [Inspect] – [Inspection] – [Search] – [Modify] – [Settings] Tab Page – [Teach] – [◀] – [Detection point]

**1** Use one of the following methods to move the cross cursor to the desired position.

The position of the cross cursor will be the coordinate position that is output. This position is registered relative to the model region.

- Drag the cross cursor to move it.
- Press [◀] – [Console] on the right of the display to display the console. You can use the cross cursor on the console to change the coordinate values one pixel at a time.

Drag the cross cursor.

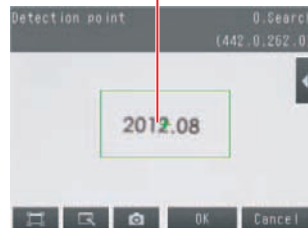

### Note

The detection coordinates will automatically return to the center coordinates of the model if you change the model region.

## Measurement Data That Can Be Used for External Outputs and Calculations

The following values can be used as measurement data and output to external devices via the Ethernet or used in calculations.

Expression text string	Data name	Description	Data range
JG	Judgement	This is the judgement result.	-2: No judgement (not measured), 0: Judgement is OK, -1: Judgement is NG, -13: Teaching not performed error, -14: Figure not registered error, -15: Out of range error
CR[0] to CR[31]	Correlation	This is the correlation of the Nth model that was found.	0 to 100
X[0] to X[31]	Position X	This is the X coordinate where the Nth model was found.	-99,999.9999 to 99,999.9999
Y[0] to Y[31]	Position Y	This is the Y coordinate where the Nth model was found.	-99,999.9999 to 99,999.9999
TH[0] to TH[31]	Angle	This is the angle in which the Nth model was found.	-180 to 180
SX	Reference X	This is the X coordinate of the position where the model was registered.	-99,999.9999 to 99,999.9999
SY	Reference Y	This is the Y coordinate of the position where the model was registered.	-99,999.9999 to 99,999.9999
ST	Reference angle	This is the angle when the model was registered.	-180 to 180
RX	Detection coordinate X	This is the X coordinate of the detection point when the model was registered.	-99,999.9999 to 99,999.9999
RY	Detection coordinate Y	This is the Y coordinate of the detection point when the model was registered.	-99,999.9999 to 99,999.9999
C	Count	This is the number of models found.	0 to 32

 4-13 Calculations and Judgements Using Inspection Item Data: p. 155

## Measurement Data That Can Be Logged

The following values can be logged as measurement data.

Parameter	Range of value	Description
Judgement	0: Judgement is OK -1: Judgement is NG -13: Teaching not performed error -14: Figure not registered error -15: Out of range error	This is the measurement judgement results.
Correlation	0 to 100	This is the measured correlation.
Position X	-99999.999 to 99999.999	This is the measurement position X.
Position Y	-99999.999 to 99999.999	This is the measurement position Y.
Angle	-180 to 180	This is the measurement angle.
Count	0 to 32	This is the number of models found.

\* When logging data is output, the data is output in the order of the above table.  
If more than one item is stored, results are output for each model.

 7-6 Logging Measurement Data and Image Data: p. 208

## Errors

### Errors in Teaching

---

A teaching error message will appear if the contrast of the image within the model registration region is too low. Select a region with a larger contrast between light and dark areas compared to the region that was registered as the model and re-register it as the model.

# 4-5 Inspecting with the Shape Search II Inspection Item

## Shape Search II Inspection Item

This inspection item is used to search for the portion of the input image that most closely resembles an image pattern that is called a model. The model is registered in advance based on a characteristic feature of the measurement object. You can output the correlation, which tells how closely the portion of the image matches the model. You can also output the position of the measurement object and the angle of the measurement object. For the normal Search inspection item, a model that concentrates on the color and brightness of the image pattern is used, but in the Shape Search II, a model that concentrates on the outline information is used. This inspection item enables robust, high-speed, high-precision detection of models even when lighting is reflected from the workpieces, when the shapes of the workpieces are inconsistent, when the orientation of the workpieces change, when noise is superimposed, when part of the image is blocked, or when there are other fluctuations in the environment.

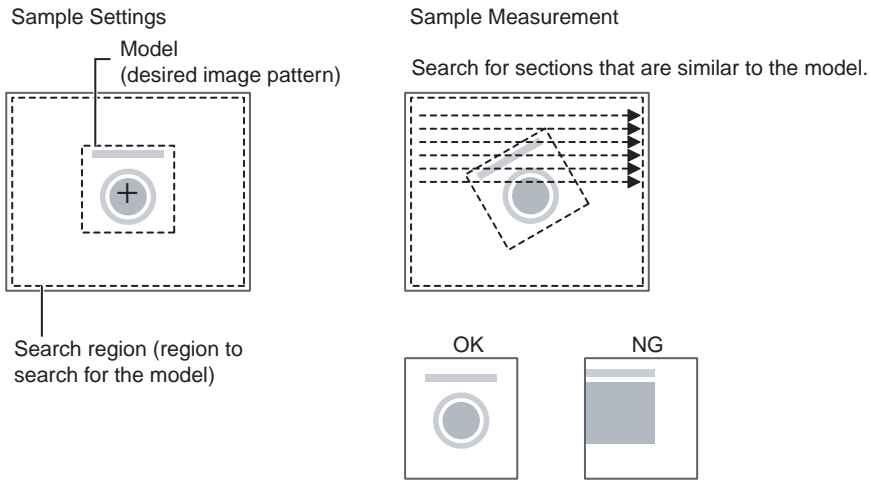

## Setup Procedure for the Shape Search II Inspection Item

### Step 1 Selecting the Inspection Item

► [Inspect] – [Inspection]

- 1 Press an unused inspection item number and press [Add item.].
- 2 Press [Shape Search II].

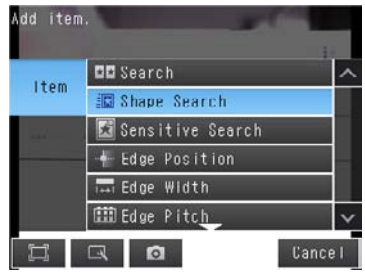

📖 Registering inspection items: p. 93

**Note**

Drag the arrow  at the bottom of the menu upward to display all of the inspection items.

## Step 2 Teaching

Teaching means to store the region and partial image as reference data for the measurement.

### ► [Inspect] – [Inspection] – [Add item.] – [Shape Search II] – [Settings] Tab Page

- 1 Press [Teach].
- 2 Place the object that is to be used as the measurement reference in front of the camera.
- 3 Move the rectangle to the location to be measured.
- 4 Press [OK].
- 5 Press [TEACH] on the lower right of the display.  
The basic settings will be registered when teaching has been completed.
- 6 Press [Back] to end teaching.

Drag the rectangle to move it.      Drag a corner to size the rectangle.

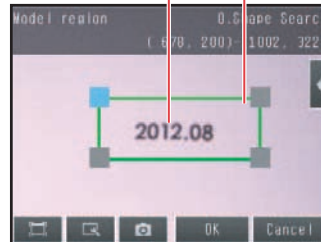

The following data is stored as the measurement reference.

Item	Parameter	Description
Reference data	Model image	This is the partial image that is stored as the reference.
	Reference position X	These are coordinates of the model image that are stored as reference.
	Reference position Y	

## Step 3 Adjusting Judgement Parameters

### ► [Inspect] – [Inspection] – [Add item.] – [Shape Search] – [Settings] Tab Page

- 1 Press [Judgement].
- 2 Press each parameter and set the range that is to be judged as OK. Set the range for each of the following parameters.

Continuous measurements will be performed for the images that are taken.

**Note**

You can change the parameters for judgement conditions on the Display Settings Display. Press [◀] – [Display setting] on the right of the display to switch to the Display Settings Display.

- 3 Press [OK] to accept the value.
- 4 Press [Back] to end making the setting.

If more than one result was detected, you can switch to a display for each result. (Multi-point output must be enabled.)

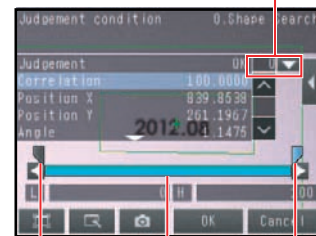

Upper limit      Lower limit

Blue for OK. Red for NG.

Parameter	Setting	Description
Correlation	Range: 0 to 100 Defaults: Lower limit: 60, Upper limit: 100	Adjust the upper and lower limits of the correlation for an OK judgement.
Position X	Range: -99,999.9999 to 99,999.9999 Defaults: Lower limit: -99,999.9999, Upper limit: 99,999.9999	Adjust the upper and lower limits of measurement position X for an OK judgement.
Position Y	Range: -99,999.9999 to 99,999.9999 Defaults: Lower limit: -99,999.9999, Upper limit: 99,999.9999	Adjust the upper and lower limits of measurement position Y for an OK judgement.
Angle	Range: -180 to 180 Defaults: Lower limit: -180, Upper limit: 180	Adjust the upper and lower limits of angle for an OK judgement.
Count	Range: 0 to 32 Defaults: Lower limit: 0, Upper limit: 32	Adjust the upper and lower limits of the detection count for an OK judgement.



### Note

- You can change the output form for each measurement value to one of the following settings.  
Press [◀] – [Result type] on the right of the display.  
Absolute value (default): The measured coordinates are output.  
Relative value: The difference from the reference position is output as coordinates.

## Obtaining Multiple Results Simultaneously

You can detect all items that satisfy the extraction conditions.

Judgement is performed for all detected results.

- ▶ **[Inspect] – [Inspection] – [Shape Search II] – [Modify] – [Details] Tab Page – [Meas. Parameter]**

- 1 Press [Sorting method] and select the conditions by which to sort the detected results.

You can output the results in the sort order that you selected.

### Note

You can specify the actual output conditions and count for outputting multiple results.

 Selecting the results to output: p. 98

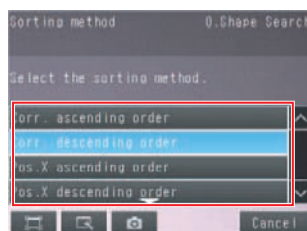

Selection item	Setting	Description
Sorting method	Corr. ascending order (ascending order of correlation value)	Sorts the results in order from the smallest correlation to the largest.
	Corr. descending order (descending order of correlation value) (default)	Sorts the results in order from the largest correlation to the smallest.
	Pos.X ascending order (ascending order of position X)	Sorts the results in order from the smallest measurement X position to the largest.
	Pos.X descending order (descending order of position X)	Sorts the results in order from the largest measurement X position to the smallest.
	Pos.Y ascending order (ascending order of position Y)	Sorts the results in order from the smallest measurement Y position to the largest.
	Pos.Y descending order (descending order of position Y)	Sorts the results in order from the largest measurement Y position to the smallest.

## Select the Results to Output

You can use multiple conditions to determine which results to output from all the objects detected with a correlation at the candidate level or higher.

Only the results that meet all the specified conditions are output.

► **[Inspect] – [Inspection] – [Shape Search II] – [Modify] – [Details] Tab Page – [Meas. Parameter]**

- 1 Press **[Extraction condition]** and adjust the candidate level so that only objects higher than a certain correlation are detected.
- 2 Set the conditions for outputting the detected objects.  
(Extraction X/Y and Detection Count)

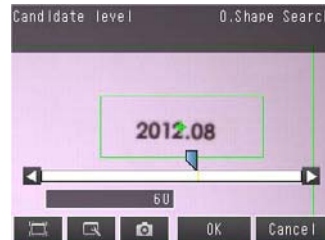

Extraction condition	Range	Description
Candidate level	0 to 100 Defaults: Lower limit: 80, Upper limit: 100	Outputs only objects with a correlation that is higher than the specified candidate level.
Extraction X	-99999.9999 to 99999.9999 Defaults: Lower limit: -99,999.9999, Upper limit: 99,999.9999	Results are output only for objects with a measured X coordinate that is within this range.
Extraction Y	-99999.9999 to 99999.9999 Defaults: Lower limit: -99,999.9999, Upper limit: 99,999.9999	Results are output only for objects with a measured Y coordinate that is within this range.
Detection count	1 to 32 Default: 1	Sets the maximum number of detection results to output.

### Note

The processing time changes if you change the candidate level.

## Reflect in Total Judgement

You can specify whether to reflect the judgement results of an inspection item in the overall judgement. (The default is to reflect them.)

► **[Inspect] – [Inspection] – [Add item.] – [Shape Search II] – [Details] Tab Page – [Output parameter]**

## Unstable Shape Search II Results

### Inclined Measurement Objects

Adjust the [Angle range] parameter to increase the range in which a search is made for the model. The Shape Search II inspection item judges whether an image is OK or NG according to the correlation with a previously registered image pattern. For this reason, if the object is at an angle, the correlation is reduced and the image may be judged as NG. To achieve an OK judgement for the same image pattern even when the object is at an angle, the rotation range must be widened.

► [Inspect] – [Inspection] – [Shape Search II] – [Modify] – [Details] Tab Page – [Model parameter]

- 1 Set [Rotation] to [Yes].
- 2 Press [Angle range] and set the following range.

Parameter	Setting	Description
Angle range	Range: -180 to 180 Default: Lower limit: -180, Upper limit: 180	A shape search II is performed within the set angle range. The larger the angle range, the longer the processing time.  <b>Important</b> If you change the angle range, perform teaching again.   p. 96

### Searching for Other Locations

If the model image consists of detailed graphic images, similar models may be detected. In that case, set the model mode to [Stable].

► [Inspect] – [Inspection] – [Shape Search II] – [Modify] – [Details] Tab Page – [Model parameter] – [Model mode]

### Correlation Is Inconsistent Due to Low Contrast

Adjust the brightness to improve the contrast of the mark.

 Adjust the brightness: p. 61

### Correlation Is Inconsistent Due to Variations in the Measurement Object

Inconsistent portions can be masked so that they are omitted from matching.

 Model masking: p. 101

## Increasing Processing Speed

The following two methods can be used to reduce processing time.

- **Reduce the range in which a shape search II is performed for the model.**

 Changing the measurement region: p. 102

- **Reduce the angle range setting.**

Adjust the [Angle range] parameter to reduce the range in which a shape search II for the model is performed.

 Setting the angle range: p. 99

## Editing the Model Regions and Measurement Region

### Changing the Model Regions

This section describes how to edit the model regions.

You can edit the model region in the same way as for a search region.

Changing the Model Registration Region to a Shape Other Than a Rectangle:  p. 100

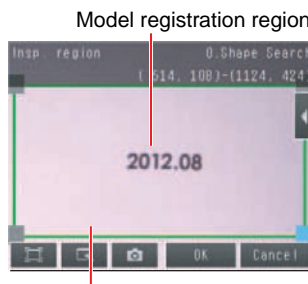

Measurement region  
(region that is searched for the model)

#### Important

If the model region is changed, perform teaching again.

 p. 96

### Changing the Measurement Region

The region within which the model is searched can be changed. In the default settings, the whole display is set as the measurement region. You can edit the measurement region in the same way as for a search region.

Changing the Measurement Region:  p. 102

## Measurement Data That Can Be Used for External Outputs and Calculations

The following values can be used as measurement data and output to external devices via the Ethernet or used in calculations.

Expression text string	Data name	Description	Data range
JG	Judgement	This is the judgement result.	-2: No judgement (not measured), 0: Judgement is OK, -1: Judgement is NG, -13: Teaching not performed error, -14: Figure not registered error, -15: Out of range error
CR[0] to CR[31]	Correlation	This is the correlation of the Nth model that was found.	0 to 100
X[0] to X[31]	Position X	This is the X coordinate where the Nth model was found.	-99,999.9999 to 99,999.9999
Y[0] to Y[31]	Position Y	This is the Y coordinate where the Nth model was found.	-99,999.9999 to 99,999.9999
TH[0] to TH[31]	Angle	This is the angle in which the Nth model was found.	-180 to 180
SX	Reference X	This is the X coordinate of the position where the model was registered.	-99,999.9999 to 99,999.9999
SY	Reference Y	This is the Y coordinate of the position where the model was registered.	-99,999.9999 to 99,999.9999
ST	Reference angle	This is the angle when the model was registered.	-180 to 180
RX	Detection coordinate X	This is the X coordinate of the detection point when the model was registered.	-99,999.9999 to 99,999.9999
RY	Detection coordinate Y	This is the Y coordinate of the detection point when the model was registered.	-99,999.9999 to 99,999.9999
C	Count	This is the number of models found.	0 to 32



4-13 Calculations and Judgements Using Inspection Item Data: p. 155

## Measurement Data That Can Be Logged

The following values can be logged as measurement data.

Parameter	Range of value	Description
Judgement	0: Judgement is OK -1: Judgement is NG -13: Teaching not performed error -14: Figure not registered error -15: Out of range error	This is the measurement judgement results.
Correlation	0 to 100	This is the measured correlation.
Position X	-99999.999 to 99999.999	This is the measurement position X.
Position Y	-99999.999 to 99999.999	This is the measurement position Y.
Angle	-180 to 180	This is the measurement angle.
Count	0 to 32	This is the number of models found.

\* When logging data is output, the data is output in the order of the above table.  
If more than one item is stored, results are output for each model.



7-6 Logging Measurement Data and Image Data: p. 208

## Errors

### Errors in Teaching

---

A teaching error message will appear if the contrast of the image within the model registration region is too low. Select a region with a larger contrast between light and dark areas compared to the region that was registered as the model and re-register it as the model.

# 4-6 Inspecting with the Sensitive Search Inspection Item

## Sensitive Search Inspection Item

This inspection item automatically divides the registered model into smaller areas and performs matching for details. The lowest correlation for all of the divisions is output. A sensitive search is suitable when the differences between the model image and measurement image are too small to produce differences in correlations with a normal search.

### Sample Settings

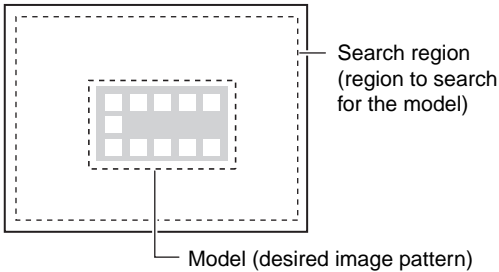

### Sample Measurement

A search is made for sections that are similar to the model and then a finely divided model is used to check the correlations in detailed divisions. If there is no pattern in the divided model, then you can inspect the degree by which there is no pattern.

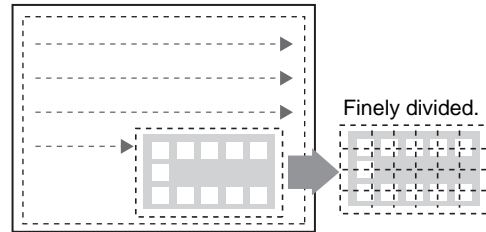

## Setup Procedure for the Sensitive Search Inspection Item

### Step 1 Selecting the Inspection Item

#### ► [Inspect] – [Inspection]

- 1 Press an unused inspection item number and press [Add item.].
- 2 Press [Sensitive Search].



 Registering inspection items: p. 93

#### Note

Drag the arrow  at the bottom of the menu upward to display all of the inspection items.

## Step 2 Teaching

Teaching means to store the region and partial image as reference data for the measurement.

### ► [Inspect] – [Inspection] – [Add item.] – [Sensitive Search] – [Settings] Tab Page

- 1 Press [Teach].
- 2 Place the object that is to be used as the measurement reference in front of the camera.
- 3 Move the rectangle to the location to be measured.
- 4 Press [OK].
- 5 Press [TEACH] on the lower right of the display.  
The basic settings will be registered when teaching has been completed.
- 6 Press [Back] to end teaching.

Drag the rectangle to move it.      Drag a corner to size the rectangle.



The following data is stored as the measurement reference.

Item	Parameter	Description
Reference data	Model image	This is the partial image that is stored as the reference.
	Reference position X	These are coordinates of the model image that are stored as reference.
	Reference position Y	

## Step 3 Adjusting Judgement Parameters

### ► [Inspect] – [Inspection] – [Add item.] – [Sensitive Search] – [Settings] Tab Page

- 1 Press [Judgement].
- 2 Press each parameter and set the range that is to be judged as OK. Set the range for each of the following parameters.  
Continuous measurements will be performed for the images that are taken.

**Note**

You can change the parameters for judgement conditions on the Display Settings Display. Press [◀] – [Display setting] on the right of the display to switch to the Display Settings Display.

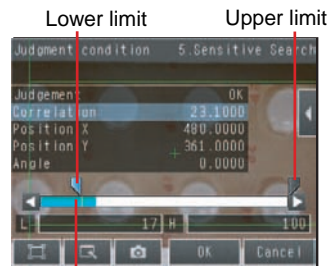

Blue for OK. Red for NG.

- 3 Press [OK] to accept the value.
- 4 Press [Back] to end making the setting.

Parameter	Setting	Description
Correlation	Range: 0 to 100 Defaults: Lower limit: 60, Upper limit: 100	Set the correlation range that is to be judged as OK. If the correlation in the measurement results is 0, the judgement will be NG regardless of the setting of the lower limit.
Position X	Range: -99,999.9999 to 99,999.9999 Defaults: Lower limit: -99,999.9999, Upper limit: 99,999.9999	Set the range of movement in the X direction that is to be judged as OK.
Position Y	Range: -99,999.9999 to 99,999.9999 Defaults: Lower limit: -99,999.9999, Upper limit: 99,999.9999	Set the range of movement in the Y direction that is to be judged as OK.
Angle	Range: -180 to 180 Defaults: Lower limit: -180, Upper limit: 180	Set the angle range that is to be judged as OK.
Count	Range: 0 to 221 Defaults: Lower limit: 0, Upper limit: 221	Set the density difference range that is to be judged as OK. The value will increase for larger percentages of areas with no pattern. This parameter is valid when setting a plain inspection area for a divided model.



**Note**

- You can change the output form for each measurement value to one of the following settings.  
Press [◀] – [Result type] on the right of the display.  
Absolute value (default): The measured coordinates are output as absolute values.  
Relative value: The difference from the reference value is output.

**Reflect in Total Judgement**

You can specify whether to reflect the judgement results of an inspection item in the overall judgement. (The default is to reflect them.)

- ▶ [Inspect] – [Inspection] – [Add item.] – [Sensitive Search] – [Details] Tab Page – [Output parameter]

**Increasing Measurement Position Accuracy**

You can increase the accuracy of measurement positioning.

You can calculate down to four decimal places.

- ▶ [Inspect] – [Inspection] – [Sensitive Search] – [Modify] – [Details] Tab Page – [Meas. Parameter]
  - 1 Press [Sub-pixel] and select [Yes].

**Select the Results to Output**

You can use multiple conditions to determine which results to output from all the objects detected with a correlation at the candidate level or higher.

Only the results that meet all the specified conditions are output.

- ▶ [Inspect] – [Inspection] – [Sensitive Search] – [Modify] – [Details] Tab Page – [Meas. Parameter]
  - 1 Press [Candidate level] and adjust the candidate level so that only objects higher than a certain correlation are detected.



Extraction condition	Range	Description
Candidate level	0 to 100	Only objects with a correlation that is higher than the specified candidate level are output.

**Note**

The processing time changes if you change the candidate level.

## Changing the Number Region Divisions

You can change the number of divisions of the registered model. The default setting is 5 × 5.

- **[Inspect] – [Inspection] – [Sensitive Search] – [Modify] – [Details] Tab Page – [Model parameter] – [Sub-model number]**

Parameter	Setting	Description
Sub-model number	3 × 3, 5 × 5 (default), or 9 × 9	Sets the number of divisions of the registered model.

## Inspecting Plain Regions

Density deviations are used to inspect sections that are set as plain regions during teaching.

- **[Inspect] – [Inspection] – [Sensitive Search] – [Modify] – [Details] Tab Page – [Model parameter] – [Plain inspection]**

Parameter	Setting	Description
Plain inspection	Yes or No (default)	Enables or disables inspecting plain sections.

## Unstable Search Results

### Inclined Measurement Objects

Adjust the [Angle range] parameter to increase the range in which a search is made for the model.

The Search inspection item judges whether an image is OK or NG according to the correlation with a previously registered image pattern. For this reason, if the object is at an angle, the correlation is reduced and the image may be judged as NG. To achieve an OK judgement for the same image pattern even when the object is at an angle, the rotation range must be widened.

- **[Inspect] – [Inspection] – [Sensitive Search] – [Modify] – [Details] Tab Page – [Model parameter]**

- 1 Set [Rotation] to [Yes].**
- 2 Press [Angle range] and set the following range.**

Parameter	Setting	Description
Angle range	Range: -180 to 180 Default: Lower limit: -180, Upper limit: 180	A search is performed within the set angle range. The larger the angle range, the longer the processing time.  <b>Important</b> If you change the angle range, perform teaching again.   p. 96

## Correlation Is Inconsistent Due to Low Contrast

Adjust the brightness to improve the contrast of the mark.

-  Adjust the brightness: p. 61

## Correlation Is Inconsistent Due to Variations in the Measurement Object

Inconsistent portions can be masked so that they are omitted from matching.

 Model masking: p. 101

## Increasing Processing Speed

The following two methods can be used to reduce processing time.

- **Reduce the range in which a search is performed for the model.**

 Changing the measurement region: p. 102

- **Reduce the angle range setting.**

Adjust the [Angle range] parameter to reduce the range in which a search for the model is performed.

 Setting the angle range: p. 99

## Editing the Model Regions and Measurement Region

### Changing the Model Regions

This section describes how to edit the model regions. You can edit the model region in the same way as for a search region.

Changing the Model Registration Region to a Shape Other Than a Rectangle:  p. 100

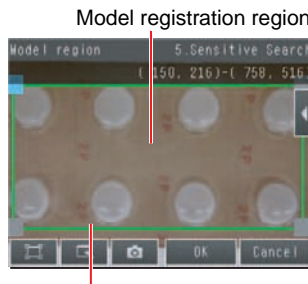

Measurement region  
(region that is searched for the model)

### Important

If the model region is changed, perform teaching again.

 p. 96

### Changing the Measurement Region

The region within which the model is searched can be changed. In the default settings, the whole display is set as the measurement region. You can edit the measurement region in the same way as for a search region.

Changing the Measurement Region:  p. 102

## Measurement Data That Can Be Used for External Outputs and Calculations

The following values can be used as measurement data and output to external devices via the Ethernet or used in calculations.

Expression text string	Data name	Description	Data range
JG	Judgement	This is the judgement result of the sensitive search.	-2: No judgement (not measured), 0: Judgement is OK, -1: Judgement is NG, -13: Teaching not performed error, -14: Figure not registered error, -15: Out of range error
CR	Correlation	Correlation	0 to 100
DV	Deviation	Density deviation	0 to 221
X	Position X	This is the X coordinate of the position where the model was found.	-999,999,999.9999 to 999,999,999.9999
Y	Position Y	This is the Y coordinate of the position where the model was found.	-999,999,999.9999 to 999,999,999.9999
TH	Angle	This is the angle of the position where the model was found.	-180 to 180
RX	Detection X	This is the X coordinate of the detection point when the model was registered.	-999,999,999.9999 to 999,999,999.9999
RY	Detection Y	This is the Y coordinate of the detection point when the model was registered.	-999,999,999.9999 to 999,999,999.9999
SX	Reference position X	This is the X coordinate of the position where the model was registered. (This is the center of the model region.)	-999,999,999.9999 to 999,999,999.9999
SY	Reference position Y	This is the Y coordinate of the position where the model was registered. (This is the center of the model region.)	-999,999,999.9999 to 999,999,999.9999
ST	Reference angle	This is the angle when the model was registered.	-180 to 180
CT	NG sub-region	This is the number of NG sub-regions.	0 to 100
AN	Sub-region number	This is the number of the regions with the lowest correlation.	0 to 99
ANX	Sub-region number (X)	This is the column number in the X direction of the output region.	0
ANY	Sub-region number (Y)	This is the row number in the Y direction of the output region.	0
DX	Sub-region pos. X	This is the X coordinate of the sub-region that was found.	-999,999,999.9999 to 999,999,999.9999
DY	Sub-region pos. Y	This is the Y coordinate of the sub-region that was found.	-999,999,999.9999 to 999,999,999.9999
CRN[0] to CRN[99]	Correlation (sub-region)	This is the correlation of the sub-region that was found.	0 to 100
DVN[0] to DVN[99]	Deviation (sub-region)	This is the density deviation of the region that was found.	0 to 221

 4-13 Calculations and Judgements Using Inspection Item Data: p. 155

## Measurement Data That Can Be Logged

The following values can be logged as measurement data.

Parameter	Range of value	Description
Judgement	-2: No judgement (not measured), 0: Judgement is OK, -1: Judgement is NG, -13: Teaching not performed error, -14: Figure not registered error, -15: Out of range error	This is the judgement result of the sensitive search.
Correlation	0 to 100	Correlation
D deviation	0 to 221	Density deviation
Position X	-99,999.9999 to 99,999.9999	This is the X coordinate of the position where the model was found.
Position Y	-99,999.9999 to 99,999.9999	This is the Y coordinate of the position where the model was found.
Angle	-180 to 180	This is the angle of the position where the model was found.
NG sub-region	0 to 100	This is the number of NG sub-regions.
Sub-region number	0 to 99	This is the number of the regions with the lowest correlation.
Sub-region pos. X (sub-region number (X))	0 to 9	This is the column number in the X direction of the output region.
Sub-region pos. Y (sub-region number (Y))	0 to 9	This is the row number in the Y direction of the output region.
Sub-region position X	-999,999,999.9999 to 999,999,999.9999	This is the X coordinate of the sub-region that was found.
Sub-region position Y	-999,999,999.9999 to 999,999,999.9999	This is the Y coordinate of the sub-region that was found.
Correlation (sub-region)	0 to 100	Correlation
Deviation (sub-region)	0 to 221	Density deviation

\* When logging data is output, the data is output in the order of the above table.

 7-6 Logging Measurement Data and Image Data: p. 208

## Errors

### Errors in Teaching

A teaching error message will appear if the contrast of the image within the model registration region is too low. Select a region with a larger contrast between light and dark areas compared to the region that was registered as the model and re-register it as the model.

# 4-7 Inspecting with the Edge Position Inspection Item

## Edge Position

This inspection item is used to inspect positions. For example, it can be used to see if a label is attached at the correct position or if a product is set in the correct position.

Places where the color changes greatly are called edges. The positions of these edges are measured.

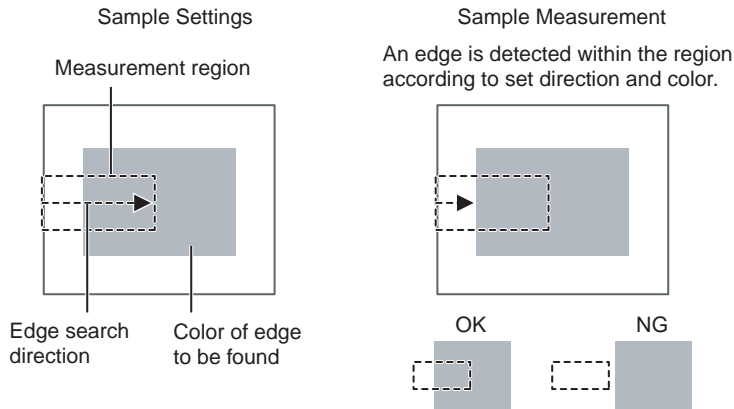

## Setup Procedure for Edge Position

### Step 1 Selecting the Inspection Item

#### ► [Inspect] – [Inspection]

- 1 Press an unused inspection item number and press [Add item.].
- 2 Press [Edge position].

 Registering inspection items: p. 93



#### Note

Drag the arrow  at the bottom of the menu upward to display all of the inspection items.

## Step 2 Teaching

Teaching means to store the region and the edge position in the region as reference data for the measurement.

### ► [Inspect] – [Inspection] – [Add item.] – [Edge Position] – [Settings] Tab Page

- 1 Press [Teach].
- 2 Place the object that is to be used as the measurement reference in front of the camera.
- 3 Move the rectangle to the location to be measured.
- 4 Press [OK].
- 5 Press [TEACH] on the lower right of the display.  
The basic settings will be registered when teaching has been completed.
- 6 Press [Back] to end teaching.

The arrow in the middle shows the direction for detecting an edge.



Moves the starting point of the measurement region.  
Drag to move the region.

Moves the end point of the measurement region.  
Changes the width of the measurement region.

Changing the measurement region: p. 102

The following data is stored as basic measurement data.

Item	Parameter	Description
Reference data	Reference position X	The reference coordinates (X, Y) of the position are set automatically.
	Reference position Y	

## Step 3 Adjusting Judgement Parameters

### ► [Inspect] – [Inspection] – [Add item.] – [Edge Position] – [Settings] Tab Page

- 1 Press [Judgement].
- 2 Press the parameters and set the range that is to be judged as OK.  
The measurement value is displayed next to the parameter name. Continuous measurements will be performed for the images that are displayed.

**Note**

You can change the parameters for judgement conditions on the Display Settings Display. Press [◀] – [Display setting] on the right of the display to switch to the Display Settings Display.

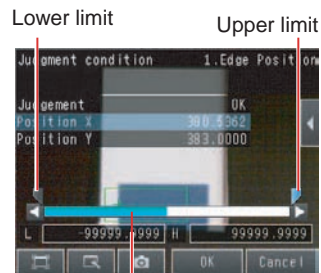

Blue for OK. Red for NG.

- 3 Press [OK] to enter the value.

Parameter	Setting	Description
Position X	Range: -99,999.9999 to 99,999.9999 Defaults: Lower limit: -99,999.9999, Upper limit: 99,999.9999	Adjust the upper and lower limits of edge position X for an OK judgement.
Position Y	Range: -99,999.9999 to 99,999.9999 Defaults: Lower limit: -99,999.9999, Upper limit: 99,999.9999	Adjust the upper and lower limits of edge position Y for an OK judgement.

**Note**

- You can change the output form for each measurement value to one of the following settings.  
Press [◀] – [Result type] on the right of the display.  
Absolute value (default): The measured coordinates are output as absolute values.  
Relative value: The difference from the reference value is output.

## Reflect in Total Judgement

You can specify whether to reflect the judgement results of an inspection item in the overall judgement. (The default is to reflect them.)

► **[Inspect] – [Inspection] – [Add item.] – [Edge Position] – [Details] Tab Page – [Output parameter]**

## Changing Edge Detection Conditions (Sensors with Monochrome Cameras Only)

You can change the following measurement conditions for Sensors with Monochrome Cameras.

► **[Inspect] – [Inspection] – [Edge Position] – [Modify] – [Details] Tab Page – [Meas. Parameter]**

Item	Parameter	Description
Density change	Light to Dark	Detects as an edge any position within the specified region that changes from white to black.
	Dark to Light	Detects as an edge any position within the specified region that changes from black to white.
Measurement methods	Projection	A projection is formed based on the gray level, and any position of intersection between the gray level value and the threshold (edge level) is detected as an edge. This detection method is used when you must process an image with excessive noise or when the edges are blurry.
	Differentiation	A differentiated waveform is created that represents the amount of change in gray level between neighboring pixels. The maximum value of the differentiated waveform that exceeds the threshold (edge level) is detected as an edge. This detection method is used for low-contrast images.

## Unstable Edge Position Results

### There Is an Edge But It Cannot Be Detected

► **[Inspect] – [Inspection] – [Edge Position] – [Modify] – [Details] Tab Page – [Meas. Parameter] – [Edge Level]**

Parameter	Setting	Description
Edge level	Range: 0 to 100 Default: 50	Set the color change level to detect as an edge. The edge point is found based on a threshold that is set for a color change.  <b>Important</b> If you change the edge level, perform teaching again.

**Note**

### Edge Level

An edge is detected in the following way.

1. The color change distribution of the entire measurement region is determined.
2. The minimum color change is 0%. The maximum color change is 100%.
3. The location where the color change intersects with the edge level is detected as the edge.

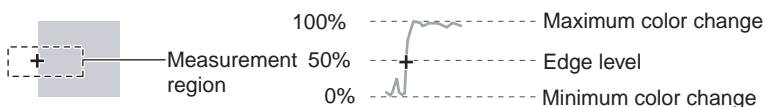



## Noise Is Mistaken as an Edge

### ► [Inspect] – [Inspection] – [Edge Position] – [Modify] – [Details] Tab Page – [Meas. Parameter] – [Noise Level]

Parameter	Setting	Description
Noise level	Sensors with Color Cameras Only Range: 0 to 422 Default: 5  (Sensors with Monochrome Cameras only) Range: 0 to 255 Default: 128	Sets the density level to be considered as noise. If the difference between the maximum and minimum color changes in the region is below the noise level, it will be assumed that there is no edge. Increase this value if noise is incorrectly detected as an edge.  <b>Important</b> If you change the noise level, perform teaching again.

#### Note

### Noise threshold

The maximum and minimum color deviations and densities within the edge detection region are determined. If the difference is less than the noise threshold, it is assumed that there are no edges. Normally there is no problem with the default value of 10, but if noise is mistakenly detected as an edge, make this value higher.

- Sensors with Color Camera  
Within the Region  
Max. color change – Min. color change < Noise threshold → No edge found → Measurement result: NG  
Max. color change – Min. color change ≥ Noise threshold → Edge found → Perform measurement
- Sensors with Monochrome Cameras  
Max. density change – Min. density change < Noise threshold → No edge found → Measurement result: NG  
Max. density change – Min. density change – Noise threshold → Edge found → Perform measurement

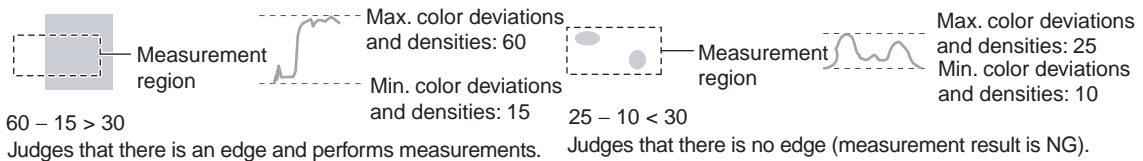

### Screen Display When the Edge Level and Noise Level Are Changing

A bar showing the threshold level moves up and down on the graphic as the edge level/noise level value changes. A cross-key cursor will also appear at the detected edge position.

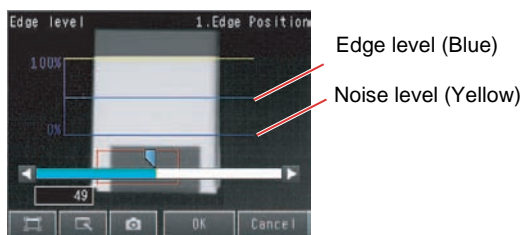

Screen display when the edge level are changing.

## Undesired Edge Position Is Automatically Detected When Teaching (Sensors with Color Cameras Only)

Manually set the color of the edge that you want to detect.

► **[Inspect] – [Inspection] – [Edge Position] – [Modify] – [Settings] Tab Page – [Teach]**

- 1 Press [◀] – [Color ON/OFF] on the right side of the display.
- 2 Press [ON].
- 3 Press [◀] – [Set color.] on the right of the display.
- 4 Press [◀] – [Detection mode] on the right of the display and select one of the following detection modes.
- 5 Draw a rectangle around the color that you want to use to extract an edge.  
The specified color will be extracted.
- 6 Press [OK] to enter the edge color.
- 7 Press [TEACH] again.
- 8 Press [Back].

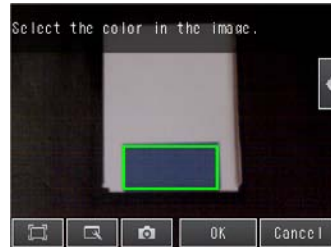

(Only a rectangle can be used to specify the region.)

Item	Parameter	Description
Detection mode	Color IN	Detects as an edge any position where the color changes from another color to the specified color.
	Color OUT	Detects as an edge any position where the color changes from the specified color to another color.

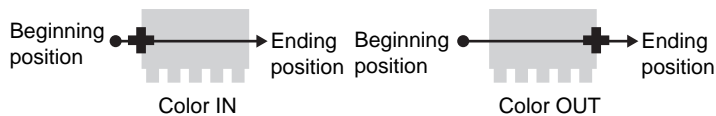

### Note

It is also possible to check the extraction colors or specify them using the color palette. The RGB values of the extraction color can be checked and adjusted using the color palette. If you press [◀] – [Color palette], a color palette will appear.

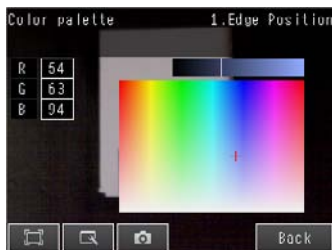

When a color is pressed on the color palette, its RGB values will be displayed.

## Increasing Processing Speed for Edge Position

Make the measurement region smaller to reduce the processing time.

 Changing the measurement region: p. 102

## Measurement Data That Can Be Used for External Outputs and Calculations

The following values can be used as measurement data and output to external devices via the Ethernet or used in calculations.

Expression text string	Data name	Description	Data range
JG	Judgement	This is the judgement result.	-2: No judgement (not measured), 0: Judgement is OK, -1: Judgement is NG, -13: Teaching not performed error, -14: Figure not registered error, -15: Out of range error
X	Position X	This is the X coordinate of the measured edge position.	-99999.9999 to 99999.9999
Y	Position Y	This is the Y coordinate of the measured edge position.	-99999.9999 to 99999.9999
SX	Ref. position X (reference position X)	This is the X coordinate of the edge position when a range is set.	-99999.9999 to 99999.9999
SY	Ref. position Y (reference position Y)	This is the Y coordinate of the edge position when a range is set.	-99999.9999 to 99999.9999
DF	D. position (difference in position)	This is the offset from the measured reference position.	-99999.9999 to 99999.9999

 4-13 Calculations and Judgements Using Inspection Item Data: p. 155

## Measurement Data That Can Be Logged for Edge Position

The following values can be logged as measurement data.

Measured item	Range of value	Description
Judgement	0: Judgement is OK -1: Judgement is NG -13: Teaching not performed error -14: Figure not registered error -15: Out of range error	This is the measurement judgement results.
D. position (difference in position)	-893 to 893	This is the offset from the measured reference position.
Position X	-99999.9999 to 99999.9999	This is the X coordinate of the measured edge position.
Position Y	-99999.9999 to 99999.9999	This is the Y coordinate of the measured edge position.

\* When logging data is output, the data is output in the order of the above table.  
If more than one item is stored, results are output for each model.

 7-6 Logging Measurement Data and Image Data: p. 208

## Errors

### Errors in Teaching

A teaching error message will appear if the edge position cannot be detected when teaching. Perform the following.

- If the color of the measurement object has changed from the specified color, set the color again and try teaching again.
- If there is an edge and it cannot be detected, adjust the [Noise level] on the [Details] Tab Page and try teaching again.

### Edge Not Found

If an edge is not found, the measurement result will be NG. Perform the following.

- If a color was specified, make sure the color of the measurement object has not changed from the specified color.
- Set the color again if necessary.
- If there is an edge and it cannot be detected, make sure the [Edge level] parameter on the [Details] Tab Page is correct.



Edge level: p. 122

# 4-8 Inspecting with the Edge Width Inspection Item

## Edge Width Inspection Item

This inspection item is used to measure dimensions. Places where the color changes greatly are called edges. The distance between two edges is called the edge width.

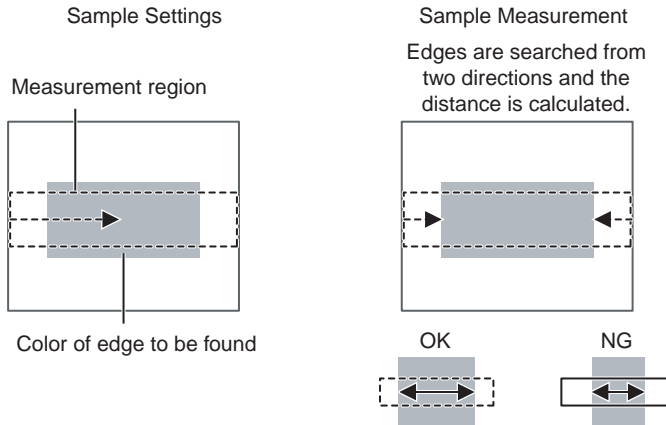

## Setup Procedure for Edge Width Inspection Item

### Step 1 Selecting the Inspection Item

► [Inspect] – [Inspection]

- 1 Press an unused inspection item number and press [Add item.].
- 2 Press [Edge Width].

 Registering inspection items: p. 93



#### Note

Drag the arrow  at the bottom of the menu upward to display all of the inspection items.

## Step 2 Teaching

Teaching means to store the region and the edge width in the region as reference data for the measurement.

### ► [Inspect] – [Inspection] – [Add item.] – [Edge Width] – [Settings] Tab Page

- 1 Press [Teach].
- 2 Place the object that is to be used as the measurement reference in front of the camera.
- 3 Move the rectangle to the location to be measured.
- 4 Press [OK].
- 5 Press [TEACH] on the lower right of the display.  
The basic settings will be registered when teaching has been completed.
- 6 Press [Back] to end teaching.

The middle arrow is the direction for detecting an edge.

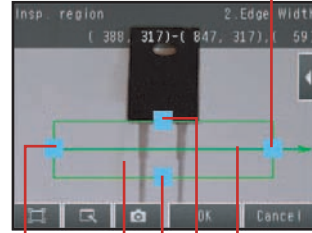

- Moves the starting point of the measurement region.
- Drag to move the region.
- Moves the end point of the measurement region.
- Changes the width of the measurement region.

Changing the measurement region: p. 102

The following data is stored as the measurement reference.

Item	Parameter	Description
Reference data	Reference width	The reference edge width is set automatically.

## Step 3 Adjusting the Judgement Parameters

### ► [Inspect] – [Inspection] – [Add item.] – [Edge Width] – [Settings] Tab Page

- 1 Press [Judgement].
- 2 Set the D. Width range for an OK judgement.  
Continuous measurements will be performed for the images that are displayed. The measured value is displayed beside the parameter name.

#### Note

You can change the parameters for judgement conditions on the Display Settings Display. Press [◀] – [Display setting] on the right of the display to switch to the Display Settings Display.

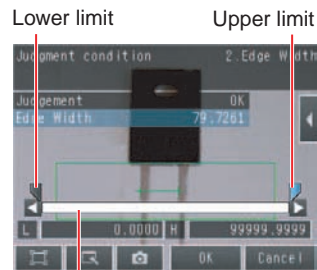

Blue for OK. Red for NG.

- 3 Press [OK] to enter the value.

Item	Parameter	Setting	Description
Judgement parameters	Edge width (edge in width)	When the result type is set to relative values: Range: -99,999.9999 or 99,999.999 Default: Upper limit: 99,999.9999, Lower limit: -99,999.9999 When the result type is set to ratios: Range: 0.000 to 999.9999(%) Default: Upper limit: 999.9999, Lower limit: 0.000	Set the upper and lower limits of the reference width for an OK judgement.

## Note

- You can change the output form for each measurement value to one of the following settings.  
Press [◀] – [Result type] on the right of the display.  
Absolute value (default): The measured edge width is output.  
Relative value: The difference from the reference value is output.  
Ratio: The percentage of the reference value is output.

## Changing Edge Detection Conditions (Sensors with Monochrome Cameras Only)

You can change the measurement conditions for Sensors with Monochrome Cameras. Change the [Density change] and [Measurement method] parameters.

 p. 122

## Reflect in Total Judgement

You can specify whether to reflect the judgement results of an inspection item in the overall judgement. (The default is to reflect them.)

▶ [Inspect] – [Inspection] – [Add item.] – [Edge Width] – [Details] Tab Page – [Output parameter]

## Unstable Edge Width Results (Sensors with Color Cameras)

If the measurement result is not stable, adjust the [Edge level], [Noise level], and [Set color.] parameters.

 p. 122

## Increasing Edge Width Processing Speed

Make the measurement region smaller to reduce the processing time.

 Changing the measurement region: p. 102

## Measurement Data That Can Be Used for External Outputs and Calculations

The following values can be output to external devices or used in calculations as measurement data.

Expression text string	Data name	Description	Data range
JG	Judgement	This is the judgement result.	-2: No judgement (not measured), 0: Judgement is OK, -1: Judgement is NG, -13: Teaching not performed error, -14: Figure not registered error, -15: Out of range error
W	Edge width	Edge width	0 to 99999.9999
SW	Ref. edge width (reference edge width)	This is the reference edge width from when the model was registered.	0 to 99999.9999
DF	D. edge width (difference in edge width)	This is the difference between the reference edge width and the measured edge width.	0 to 99999.9999

 4-13 Calculations and Judgements Using Inspection Item Data: p. 155

## Measurement Data That Can Be Logged for Edge Width

The following values can be logged as measurement data.

Measured item	Range of value	Description
Judgement	0: Judgement is OK, -1: Judgement is NG, -13: Teaching not performed error, -14: Figure not registered error, -15: Out of range error	This is the measurement judgement results.
Edge Width (edge in width)	-99999.9999 to 99999.9999	This is the difference between the reference width and the measured edge width.

\*1 When logging data is output, the data is output in the order of the above table. If more than one item is stored, results are output for each model.

 7-6 Logging Measurement Data and Image Data: p. 208

## Errors

### Errors in Teaching

A teaching error message will appear if the edge position cannot be detected when teaching. Perform the following.

- If the color of the measurement object has changed from the specified color, set the color again and try teaching again.
- If there is an edge and it cannot be detected, adjust the [Noise level] on the [Details] Tab Page and try teaching again.

If an edge is not detected when teaching, 0 will be registered as the reference width. If the result is OKed when there is not edge, set the judgement parameters for a reference position of 0.

### Edge Not Found

The measured edge width will be 0. Perform the following.

- If a color was specified, make sure the color of the measurement object has not changed from the specified color.
- Set the color again if necessary.
- If there is an edge and it cannot be detected, make sure the [Edge level] parameter on the [Details] Tab Page is correct.

 Edge level: p. 122



# 4-9 Inspecting with the Edge Pitch Inspection Item

## Edge Pitch Inspection Item

This inspection item is used to detect edges through changes in brightness within a region. Edges of the specified color in one measurement area are found and the number objects, object width, and pitch are output.

Sample Settings

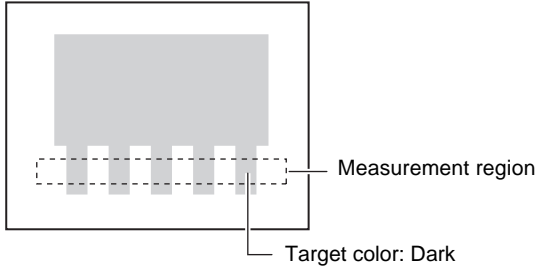

Sample Measurement

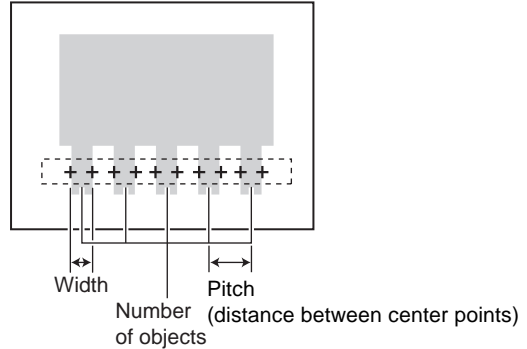

## Setup Procedure for Edge Width Inspection Item

### Step 1 Selecting the Inspection Item

► [Inspect] – [Inspection]

- 1 Press an unused inspection item number and press [Add item.].
- 2 Press [Edge Pitch].

 Registering inspection items: p. 93



#### Note

Drag the arrow  at the bottom of the menu upward to display all of the inspection items.

## Step 2 Teaching

Teaching means to store the region as reference data for the measurement.

### ► [Inspect] – [Inspection] – [Add item.] – [Edge Pitch] – [Settings] Tab Page

- 1 Press [Teach].
- 2 Place the object that is to be used as the measurement reference in front of the camera.
- 3 Move the rectangle to the location to be measured.
- 4 Press [OK].

 Changing the Measurement Region: p. 102

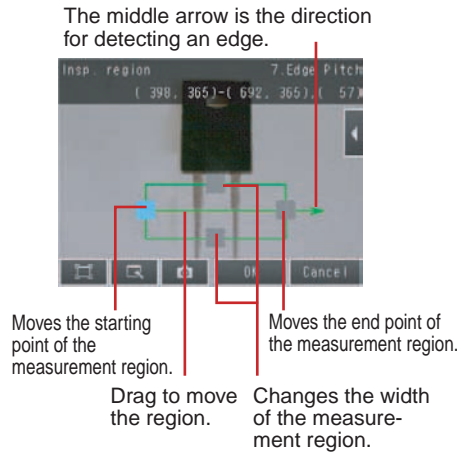

## Step 3 Adjusting the Judgement Parameters

### ► [Inspect] – [Inspection] – [Add item.] – [Edge Pitch] – [Settings] Tab Page

- 1 Press [Judgement].
- 2 Press the parameters and set the range that is to be judged as OK.  
Continuous measurements will be performed for the images that are displayed. The measured value is displayed beside the parameter name.

**Note**

You can change the parameters for judgement conditions on the Display Settings Display. Press [◀] – [Display setting] on the right of the display to switch to the Display Settings Display.

- 3 Press [OK] to enter the value.

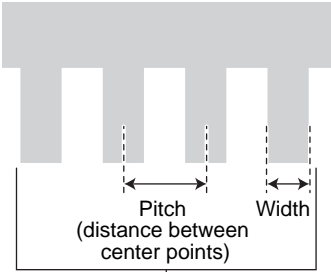

Item	Parameter	Setting	Description
Judgement Parameter	Edge pitch	Range: 0 to 1000 Defaults: Lower limit: 0, Upper limit: 1000	 <p>Edge pitch (number of objects)</p>
	Average pitch	Range: 0.0000 to 99,999.9999 Defaults: Lower limit: 0.0000, Upper limit: 99,999.9999	
	Max. pitch (maximum pitch)	Range: 0.0000 to 99,999.9999 Defaults: Lower limit: 0.0000, Upper limit: 99,999.9999	
	Min. pitch (minimum pitch)	Range: 0.0000 to 99,999.9999 Defaults: Lower limit: 0.0000, Upper limit: 99,999.9999	
	Average width	Range: 0.0000 to 99,999.9999 Defaults: Lower limit: 0.0000, Upper limit: 99,999.9999	
	Max. width (maximum pitch)	Range: 0.0000 to 99,999.9999 Defaults: Lower limit: 0.0000, Upper limit: 99,999.9999	
	Min. width (minimum pitch)	Range: 0.0000 to 99,999.9999 Defaults: Lower limit: 0.0000, Upper limit: 99,999.9999	

### Changing Edge Detection Conditions (Sensors with Monochrome Cameras Only)

You can change the following measurement conditions for Sensors with Monochrome Cameras.

► **[Inspect] – [Inspection] – [Edge Pitch] – [Modify] – [Details] Tab Page – [Meas.parameter]**

Parameter	Setting	Description
Color to count	White (default) Black	Sets the color of edges to measure.
Mode	Standard (default) Precise	Select the Precise Mode if the pin width or pitch is less than 2 pixels.

### Reflect in Total Judgement

You can specify whether to reflect the judgement results of an inspection item in the overall judgement. (The default is to reflect them.)

► **[Inspect] – [Inspection] – [Add item.] – [Edge Pitch] – [Details] Tab Page – [Output parameter]**

### Unstable Edge Pitch Results (Sensors with Color Cameras Only)

If the measurement result is not stable, adjust the [Edge level], [Noise level], and [Set color.] parameters.

 p. 122

### Increasing Edge Pitch Processing Speed

Make the measurement region smaller to reduce the processing time.

 Changing the measurement region: p. 102

## Measurement Data That Can Be Used for External Outputs and Calculations

The following values can be output to external devices or used in calculations as measurement data.

Expression text string	Data name	Description	Data range
JG	Judgement	This is the judgement result.	-2: No judgement (not measured), 0: Judgement is OK, -1: Judgement is NG, -13: Teaching not performed error, -14: Figure not registered error, -15: Out of range error
N	Edge pitch	This is the number of objects.	0 to 999
P	Average pitch	This is the average pitch.	0 to 99999.9999
PH	Max. pitch	This is the maximum pitch.	0 to 99999.9999
PL	Min. pitch	This is the minimum pitch.	0 to 99999.9999
W	Average width	This is the average width between edges.	0 to 99999.9999
WH	Max. width	This is the maximum width between edges.	0 to 99999.9999
WL	Min. width	This is the minimum width between edges.	0 to 99999.9999

 4-13 Calculations and Judgements Using Inspection Item Data: p. 155

## Measurement Data That Can Be Logged for Edge Pitch

The following values can be logged as measurement data.

Measured item	Range of value	Description
Judgement	-2: No judgement (not measured), 0: Judgement is OK, -1: Judgement is NG, -13: Teaching not performed error, -14: Figure not registered error, -15: Out of range error	This is the judgement result from the measurements.
Edge pitch	0 to 999	This is the number of objects that were detected.
Average pitch	0 to 99999.9999	This is the average pitch that was detected.
Max. pitch	0 to 99999.9999	This is the maximum pitch that was detected.
Min. pitch	0 to 99999.9999	This is the minimum pitch that was detected.
Average width	0 to 99999.9999	This is the average width that was detected between edges.
Max. width	0 to 99999.9999	This is the maximum width that was detected between edges.
Min. width	0 to 99999.9999	This is the minimum width that was detected between edges.

\* When logging data is output, the data is output in the order of the above table.

 7-6 Logging Measurement Data and Image Data: p. 208

## Errors

### Errors in Teaching

A teaching error message will appear if the edge pitch cannot be detected when teaching. Perform the following.

- If the color of the measurement object has changed from the specified color, set the color again and try teaching again.

- If there is an edge and it cannot be detected, adjust the [Noise level] on the [Details] Tab Page and try teaching again.

If an edge is not detected when teaching, 0 will be registered as the reference width. If the result is OKed when there is not edge, set the judgement parameters for a reference position of 0.

## Edge Not Found

---

The measured edge pitch will be 0. Perform the following.

- If a color was specified, make sure the color of the measurement object has not changed from the specified color.
- Set the color again if necessary.
- If there is an edge and it cannot be detected, make sure the [Edge level] parameter on the [Details] Tab Page is correct.



Edge level: p. 122

# 4-10 Inspecting with Color Data Inspection Item

## Color Data Inspection Item

This inspection item is used to perform inspections for foreign matter with a different color or for presence. The region is set for a portion of the image with the color that is to be measured. This region is called the measurement region. The average color within the measurement region is measured.

If a Sensor with a Monochrome Camera is connected, the average density in the measurement region is found and inspections are performed for the difference from the registered reference value (density average) and the variation within the measurement region (density deviation).

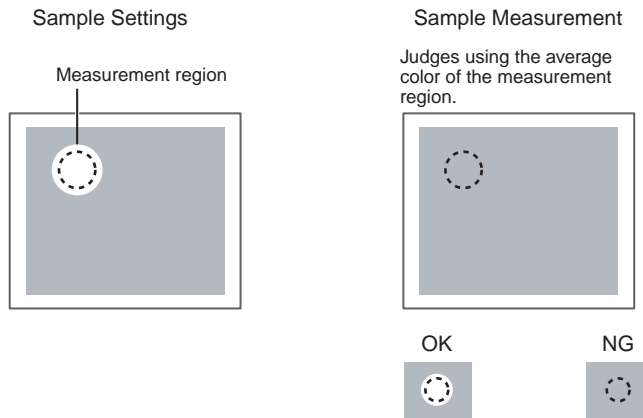

If a Sensor with a Monochrome Camera is connected, the average density in the measurement region is measured and the density deviation is used for judgements.

## Setup Procedure for Color Data Inspection Item

### Step 1 Selecting the Inspection Item

#### ► [Inspect] – [Inspection]

- 1 Press an unused inspection item number and press [Add item.].
- 2 Press [Color Data].

 Registering inspection items: p. 93



#### Note

Drag the arrow  at the bottom of the menu upward to display all of the inspection items.

## Step 2 Teaching

Teaching means to store the region and the average color in the region as reference data for the measurement.

### ► [Inspect] – [Inspection] – [Add item.] – [Color Data] – [Settings] Tab Page

- 1 Press [Teach].
- 2 Place the object that is to be used as the measurement reference in front of the camera.
- 3 Move the rectangle to the location to be measured.
- 4 Press [OK].
- 5 Press [TEACH] on the lower right of the display.  
The basic settings will be registered when teaching has been completed.
- 6 Press [Back] to end teaching.

Drag the rectangle to move it.

Drag a corner to size the rectangle.



 Changing the measurement region: p. 102

The following data is stored as the measurement reference.

Item	Parameter	Description
Reference data	Hue	The hue to use as a reference is set automatically.
	Saturation	The saturation to use as a reference is set automatically.
	Brightness	The brightness to use as a reference is set automatically.

## Step 3 Adjusting Judgement Parameters

### ► [Inspect] – [Inspection] – [Add item.] – [Color Data] – [Settings] Tab Page

- 1 Press [Judgement].
- 2 Press the parameters and set the range that is to be judged as OK.  
The measured value is displayed beside the parameter name. Continuous measurements will be performed for the images that are displayed.

#### Note

You can change the parameters for judgement conditions on the Display Settings Display. Press [◀] – [Display setting] on the right of the display to switch to the Display Settings Display.

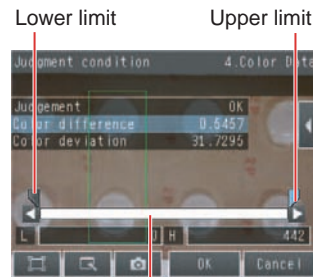

Blue for OK. Red for NG.

- 3 Press [OK] to enter the value.

### • Sensors with Color Cameras Only

Item	Parameter	Setting	Description
Judgement Parameter	Color difference	0 to 442	Sets the upper and lower limits of the difference between the average color and reference color that is to be judged as OK.
	Color deviation	0 to 221	Set the upper and lower limits of the range of the deviation in the region that is to be judged as OK.
	R average	0.0000 to 255.0000	Set the difference in the average value of the R (red) component that is to be judged as OK.
	G average	0.0000 to 255.0000	Set the difference in the average value of the G (green) component that is to be judged as OK.
	B average	0.0000 to 255.0000	Set the difference in the average value of the B (blue) component that is to be judged as OK.

### • Sensors with Monochrome Cameras only

Item	Parameter	Setting	Description
Judgement Parameter	Density average	0 to 255	Set the judgement upper and lower limits for the average density in the measurement region.
	Density deviat. (density deviation)	0.0000 to 127.0000	Set the upper and lower limits for the deviation in the average density in the measurement region.

## Reflect in Total Judgement

You can specify whether to reflect the judgement results of an inspection item in the overall judgement.

► **[Inspect] – [Inspection] – [Add item.] – [Color Data] – [Details] Tab Page – [Output parameter]**

**1** Set **[Reflect]** to **[None]**.

## Measurement Data That Can Be Used for External Outputs and Calculations

The following values can be used as measurement data and output to external devices via the Ethernet or used in calculations.

Expression text string	Data name	Description	Data range
JG	Judgement	This is the judgement result.	-2: No judgement (not measured), 0: Judgement is OK, -1: Judgement is NG, -13: Teaching not performed error, -14: Figure not registered error, -15: Out of range error
AR	R average	This is the average value of the R (red) component.	0 to 255
AG	G average	This is the average value of the G (green) component.	0 to 255
AB	B average	This is the average value of the B (blue) component.	0 to 255
AD	Color diff./dens. AV. Color difference	(For Sensors with Color Cameras) This is the difference between the average color in the region and the standard color.	0 to 442
		(For Sensors with Monochrome Cameras) This is the difference between the average density in the region and the standard density.	0 to 255
DV	Clr. deviat. Color deviation	(For Sensors with Color Cameras) This is the deviation within the region.	0 to 221
		(For Sensors with Monochrome Cameras) This is the deviation within the region.	0 to 217

 4-13 Calculations and Judgements Using Inspection Item Data: p. 155



## Measurement Data That Can Be Logged (Color Data)

The following values can be logged as measurement data.

Measured item	Range of value	Description
Judgement	0: Judgement is OK, -1: Judgement is NG, -13: Teaching not performed error, -14: Figure not registered error, -15: Out of range error	This is the measurement judgement results.
R average	0 to 255	This is the average value for the R (red) component.
G average	0 to 255	This is the average value for the G (green) component.
B average	0 to 255	This is the average value for the B (blue) component.
Color diff./dens. AV. Color (for Sensors with Color Cameras)	0 to 442	This is the difference between the color that was registered as the reference and the measured color. The average color within the measurement area is used in both cases.
Color diff./dens. AV. Color (for Sensors with Monochrome Cameras)	0 to 255	This is the difference between the average density in the region and the currently measured density.
Clr. deviat. (for Sen- sors with Color Cam- eras)	0 to 221	This is the deviation within the measurement region.
Clr. deviat. (for Sen- sors with Mono- chrome Cameras)	0 to 127	This is the deviation in the average density in the measure- ment region.

\* When logging data is output, the data is output in the order of the above table.

 7-6 Logging Measurement Data and Image Data: p. 208

## Increasing Processing Speed for Color Data

Make the measurement region smaller to reduce the processing time.

 Changing the measurement region: p. 102

# 4-11 Inspecting with the Area Inspection Item

## Area Inspection Item

This inspection item is used to measure sizes. It measures the amount of a color within the measurement region. The size is calculated as a number of pixels and it is called the area.

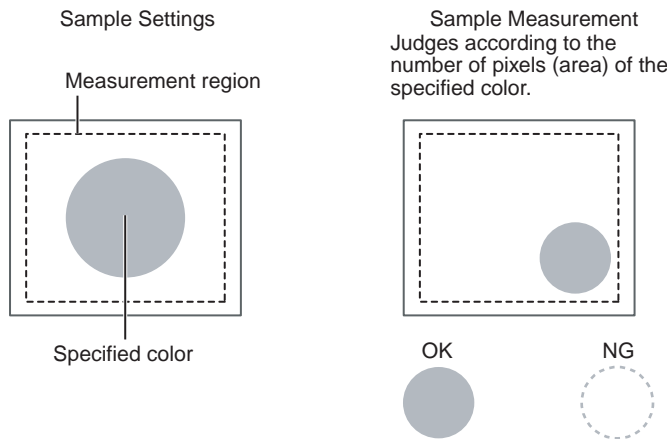

## Setup Procedure for Area

### Step 1 Selecting the Inspection Item

► [Inspect] – [Inspection]

- 1 Press an unused inspection item number and press [Add item.].
- 2 Press [Area].

 Registering inspection items: p. 93



#### Note

Drag the arrow  at the bottom of the menu upward to display all of the inspection items.

## Step 2 Teaching

Teaching means to store the region and the color area in the region as reference data for the measurement.

### ► [Inspect] – [Inspection] – [Add item.] – [Area] – [Settings] Tab Page

- 1 Press [Teach].
- 2 Place the object that is to be used as the measurement reference in front of the camera.
- 3 Move the rectangle to the location to be measured.
- 4 Press [OK].
- 5 Press [TEACH] on the lower right of the display.  
The basic settings will be registered when teaching has been completed. Areas with the extracted color will be automatically detected.

Drag the rectangle to move it. Drag a corner to size the rectangle.

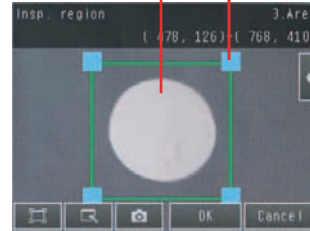

#### Note

Information on the color that has the largest area in the measurement region is extracted and registered. (The color information is extracted only the first time.) The extracted color information will not change from the second time on. To specify a desired color, refer to *Extraction Is Automatically Performed for an Undesired Color When Teaching* p. 142.

- 6 Press [Back] to end teaching.

Changing the measurement region: p. 102

The following data is stored as the measurement reference.

Item	Parameter	Description
Reference data	Extract color	This is the color for which to measure the area. The color occupying the largest area will be automatically registered. Setting Colors Manually: p. 142
	Reference area	The area to use as a reference is set automatically.

## Step 3 Adjusting Judgement Parameters

### ► [Inspect] – [Inspection] – [Add item.] – [Area] – [Settings] Tab Page

- 1 Press [Judgement].
- 2 Press the parameters and set the range that is to be judged as OK.  
The measured value is displayed beside the parameter name. Continuous measurements will be performed for the images that are displayed.

#### Note

You can change the parameters for judgement conditions on the Display Settings Display. Press [◀] – [Display setting] on the right of the display to switch to the Display Settings Display.

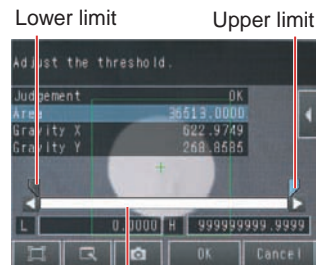

Blue for OK. Red for NG.

- 3 Press [OK] to enter the value.

Item	Parameter	Setting	Description
Judgement Parameter	Area	Range: 0.00000 to 999,999,999.9999 Default: Upper limit: 999,999,999.9999, Lower limit: 0.0000	Set the upper and lower limits for an OK judgement. The set range is the difference between the reference area and the measured areas.
	Gravity X	Range: -999,999,999.9999 to 999,999,999.9999 Default: Upper limit: 999,999,999.9999, Lower limit: -999,999,999.9999	Set the upper and lower limits of the range of gravity X that is to be judged as OK.
	Gravity Y	Range: -999,999,999.9999 to 999,999,999.9999 Default: Upper limit: 999,999,999.9999, Lower limit: -999,999,999.9999	Set the upper and lower limits of the range of the gravity Y that is to be judged as OK.

#### Note

- You can change the output form for each measurement value to one of the following settings.  
Press [◀] – [Result type] on the right of the display.  
Absolute value (default): The measured coordinates are output.  
Relative value: The difference from the reference position is output as coordinates.  
Ratio: The percentage of the reference value is output. (This applies to the area only.)

## Reflect in Total Judgement

You can specify whether to reflect the judgement results of an inspection item in the overall judgement. (The default is to reflect them.)

► [Inspect] – [Inspection] – [Add item.] – [Area] – [Details] Tab Page – [Output parameter]

## Unstable Area Results

### The Desired Color Cannot Be Detected

Add a specific color or enlarge the color range.

### Extraction Is Automatically Performed for an Undesired Color When Teaching

Manually set the color for which to measure the area.

► [Inspect] – [Inspection] – [Area] – [Modify] – [Settings] Tab Page – [Teach]

#### • Sensors with Color Cameras Only

- Press [◀] – [Set color] on the right of the display.
- Drag around the color for which you want to measure the area.  
Areas with that color will be automatically detected.  
Continuous measurements will be performed for the images that are displayed.  
Only the extracted color will appear on the display.
- Press [OK].
- Press [TEACH].
- Press [Back] to end teaching.

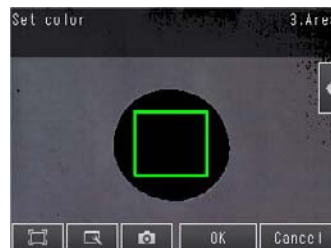

## Note

### Measuring More Than One Color

Set the colors using the color palette.

Press [◀] – [Color palette] on the Set Color Display to display the color palette. Up to four colors can be specified.

If the *Color inv.* Option is selected, the color outside the region will become the selected color.

If the *Inv.* Check Box is selected, the color outside the region will become the selected color. The [*Inv.*] Check Box applies to all colors. Select the [*Exclusion*] Check Box to exclude the selected color from extraction.

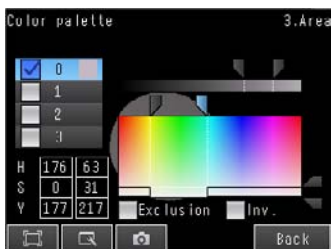

### Making the Extract Color Easier to Check

- The display for the extracted color can be switched by using [◀] – [Display setting].  
(The following display patterns can be selected for the extracted color: [Measurement image], [All color image] (default), [Selected color image], or [Binary image].)
- Press [◀] – [Background color] to change the display for colors other than the extraction color.  
(The color can be chosen from [Black] (default), [White], [Red], [Green], or [Blue].)

### • Sensors with Monochrome Cameras (or for a Color Gray Filter)

- 1 Press [◀] – [Set color] on the right of the display.
- 2 Press [◀] – [Binary level].
- 3 Specify the range of brightness to detect, and then press [OK].  
Specify the range of brightness to convert to a binary image. Measurement is performed after the image taken by the camera in 256-color grayscale is converted to a binary image. Then, white pixels are measured.
- 4 Press [OK].
- 5 Press [TEACH].
- 6 Press [Back] to end teaching.



## Note

### Making the Extraction Results Easier to Check

- You can invert the black/white extraction results.  
Press [◀] – [Reverse] and select [Yes].
- You can select whether to display a binary image.  
Press [◀] – [Binary image display] and select [OFF] or [ON].



## Changing the Area Detection Conditions

You can fill in the area detected through color extraction or binary conversion to perform a stable extraction of the areas and their characteristics or to mark only areas inside the measurement region for inspection.

► **[Inspect] – [Inspection] – [Aria] – [Modify] – [Details] Tab Page – [Meas. Parameter]**

- 1 Press **[Fill profile]** and select **[Filling up holes]** or **[Fill Outline]**.



Item	Parameter	Setting	Description
Meas.Parameter (measurement parameter)	Fill profile	Filling up holes Fill Outline None Default: None	<p>None: Holes are not filled. Filling up holes: Processes areas that are surrounded by the specified color, like in the shape of a donut, as the specified color.</p> <p><b>Input Image</b>                      <b>Filled Image</b></p>  <p><b>Fill Outline:</b> Measures the image between the first extracted point and the last extracted point in the X axis direction in the measurement area as the extracted color. Because filling is performed only in the X axis direction, this method is faster than filling up holes.</p> <p><b>Input Image</b>                      <b>Image Following Fill Outline</b></p> 

## Increasing Processing Speed for Area

Make the measurement region smaller to reduce the processing time.

📖 Changing the measurement region: p. 102

## Measurement Data That Can Be Used for External Outputs and Calculations

The following values can be used as measurement data and output to external devices via the Ethernet or used in calculations.

Expression text string	Data name	Description	Data range
JG	Judgement	This is the judgement result.	-2: No judgement (not measured), 0: Judgement is OK, -1: Judgement is NG, -13: Teaching not performed error, -14: Figure not registered error, -15: Out of range error
AR	Area	This is the area in the measurement region with the specified color.	0 to 999999999.9999
X	Gravity X	This is the X coordinate of the center of the measurement area with the specified color.	-99999.9999 to 99999.9999
Y	Gravity Y	This is the Y coordinate of the center of the measurement area with the specified color.	-99999.9999 to 99999.9999
SA	Reference area	This is the area with the specific color to be measured when a range is set.	0 to 999999999
SX	Ref. point X (reference point X)	This is the X coordinate of the center of gravity when a range is set.	-99999.9999 to 99999.9999
SY	Ref. point Y (reference point Y)	This is the Y coordinate of the center of gravity when a range is set.	-99999.9999 to 99999.9999

 4-13 Calculations and Judgements Using Inspection Item Data: p. 155

## Measurement Data That Can Be Logged for Area

The following values can be logged as measurement data.

Measured item	Range of value	Description
Judgement	0: Judgement is OK, -1: Judgement is NG, -13: Teaching not performed error, -14: Figure not registered error, -15: Out of range error	This is the measurement judgement results.
Area	0 to 99999.9999	This is the measured color area.
Gravity X	-99999.9999 to 99999.9999	This is the detected center of gravity X coordinate.
Gravity Y	-99999.9999 to 99999.9999	This is the detected center of gravity Y coordinate.

\* When logging data is output, the data is output in the order of the above table.

 7-6 Logging Measurement Data and Image Data: p. 208

## Errors

### Errors in Teaching

A teaching error message will appear if the reference area registered during teaching is 0. Perform the following.

- If the color of the measurement object has changed from the specified color, set the color again and try teaching again.

If the specified color is not found during teaching, the reference area will be registered as 0. If having no area is OK, adjust the judgement parameters with this value as the reference.

# 4-12 Inspecting with the Labeling Inspection Item

## Labeling

One region of the color you want to measure is counted as a Label. You can sort these labels by position or size, and assign numbers to them. You can then output the total number of labels, and size and position of a desired label.

### Sample Settings

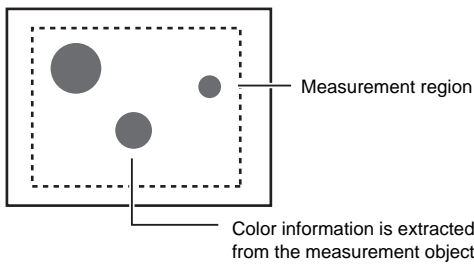

### Sample Measurement

Regions of the extracted color are detected as labels.

Total number of detected labels: 3

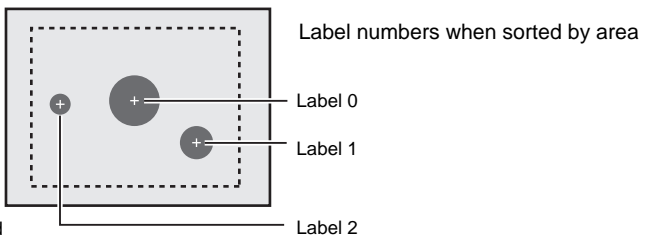

### Note

If a Sensor with Color Camera is connected, you can specify up to four colors to measure. If a Sensor with Monochrome Camera is connected, the image is converted to a black and white binary image. Then, white pixels are measured.

## Setup Procedure for Labeling Inspection Item

### Step 1 Selecting the Inspection Item

#### ► [Inspect] – [Inspection]

- 1 Press an unused inspection item number and press [Add item.].
- 2 Press [Labeling].

 Registering Inspection Items: p. 93



### Note

Drag the arrow  at the bottom of the menu upward to display all of the inspection items.



## Step 2 Teaching

Teaching means to register the region and label characteristics in that region as reference data for measurements.

### • Sensors with Color Cameras Only

#### ► [Inspect] – [Inspection] – [Add item.] – [Labeling] – [Settings] Tab Page

- 1 Press [Teach].
- 2 Place the object that is to be used as the measurement reference in front of the camera.
- 3 Move the rectangle to the location to be measured.
- 4 Press [OK].
- 5 Press [TEACH] on the lower right of the display.  
The basic settings will be registered when teaching has been completed.

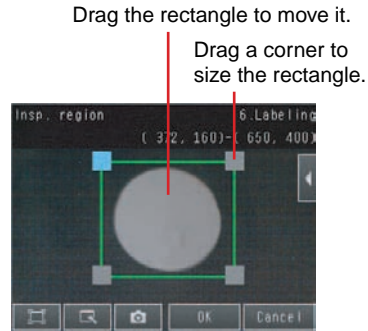

#### Note

Information on the color that has the largest area in the measurement region is extracted and registered. (The color information is extracted only the first time.) The extracted color information will not change from the second time on. To specify a desired color, refer to *Extraction Is Automatically Performed for an Undesired Color When Teaching* p. 142.

- 6 Press [Back] to end teaching.

Changing the measurement region: p. 110

#### Note

If you press the [TEACH] Button without specifying a color, the color with the largest area in the measurement region will be extracted and the resulting color information will be registered.

The following data is stored as the measurement reference.

Item	Parameter	Description
Reference data	Reference area	The area for label 0 to use as a reference is set automatically.
	Reference position X	The gravity position X for label 0 to use as a reference is set automatically.
	Reference position Y	The gravity position Y for label 0 to use as a reference is set automatically.

## Step 3 Adjusting Judgement Parameters

#### ► [Inspect] – [Inspection] – [Add item.] – [Labeling] – [Settings] Tab Page

- 1 Press [Judgement].
- 2 Press the parameters and set the OK ranges.  
Set the range for each of the following parameters. Continuous measurements will be performed for the images that are taken.
- 3 Press [OK] to accept the value.

If more than one result was detected, you can switch to a display for each result.

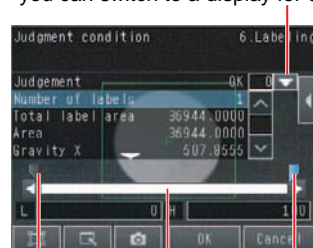

Upper limit Lower limit  
Blue for OK. Red for NG.

Item	Parameter	Setting	Description
Judgment parameters	Number of labels	Range: 0 to 100 Defaults: Upper limit: 100, Lower limit: 0	Set the upper and lower limits of the number of labels for an OK judgement.
	Total label area	Range: 0 to 999,999,999.9999 Defaults: Upper limit: 999,999,999.999, Lower limit: 0	Set the upper and lower limits of the total label area for an OK judgement.
	Area	Range: 0 to 999,999,999.9999 Defaults: Upper limit: 999,999,999.999, Lower limit: 0	Sets the upper and lower limits of the area for an OK judgement.
	Gravity center X	Range: -99,999.999 to 99,999.999 Defaults: Upper limit: 99,999.999, Lower limit: -99,999.999	Set the upper and lower limits of the gravity X for an OK judgement.
	Gravity center Y	Range: -99,999.999 to 99,999.999 Defaults: Upper limit: 99,999.999, Lower limit: -99,999.999	Set the upper and lower limits of the gravity Y for an OK judgement.
	Master angle	Range: -180 to 180 Defaults: Upper limit: 180, Lower limit: -180	Sets the upper and lower limits of the master angle for an OK judgement.

## Unstable Labeling Results

### The Desired Color Cannot Be Detected

Add a specific color or enlarge the color range.

### Extraction Is Automatically Performed for an Undesired Color When Teaching

Manually set the color for which to measure the labeling.

► **[Inspect] – [Inspection] – [Area] – [Modify] – [Settings] Tab Page – [Teach]**

#### • Sensors with Color Cameras Only

- 1** Press [**◀**] – [**Set color**] on the right of the display.
- 2** Drag around the color for which you want to measure the labeling.  
Labeling with that color will be automatically detected.  
Continuous measurements will be performed for the images that are displayed.  
Only the extracted color will appear on the display.
- 3** Press [**OK**].
- 4** Press [**TEACH**].
- 5** Press [**Back**] to end teaching.



### Measuring More Than One Color

Set the colors using the color palette.

Press [◀] – [Color palette] on the Set Color Display to display the color palette. Up to four colors can be specified.

If the *Color inv.* Option is selected, the color outside the region will become the selected color.

The [Inv.] Check Box applies to all colors. Select the [Exclusion] Check Box to exclude the selected color from extraction.

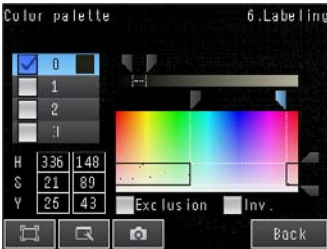

### Making the Extract Color Easier to Check

- The display for the extracted color can be switched by using [◀] – [Display setting].  
(The following display patterns can be selected for the extracted color: [Measurement image], [All color image] (default), [Selected color image], or [Binary image].)
- Press [◀] – [Background color] to change the display for colors other than the extraction color.  
(The color can be chosen from [Black] (default), [White], [Red], [Green], or [Blue].)

### • Sensors with Monochrome Cameras (or for a Color Gray Filter)

- 1 Press [◀] – [Binary level] on the right of the display.
- 2 Specify the range of brightness to detect, and then press [OK].  
Specify the range of brightness to convert to a binary image. Measurement is performed after the image taken by the camera in 256-color grayscale is converted to a binary image. Then, white pixels are measured.
- 3 Press [OK].
- 4 Press [TEACH].
- 5 Press [Back] to end teaching.

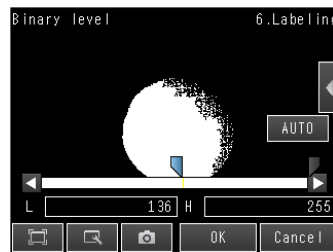

### Making the Extraction Results Easier to Check

- You can invert the black/white extraction results.  
Press [◀] – [Reverse] and select [Yes].
- You can select whether to display a binary image.  
Press [◀] – [Binary image display] and select [OFF] or [ON].

## Changing the Label Detection Conditions

You can fill in the labels detected through color extraction or binary conversion to perform a stable extraction of the labels and their characteristics or to mark only labels inside the measurement region for inspection.

► **[Inspect] – [Inspection] – [Labeling] – [Modify] – [Details] Tab Page – [Meas. Parameter]**

- 1 To enable filling up holes, press **[Filling up holes]** and select **[Yes]**.
- 2 To extract an image, press **[Extract image]** and select **[Yes]**.

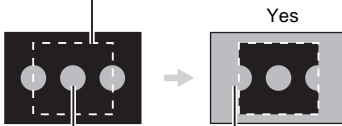

Parameter	Setting	Description
Filling up holes	Yes No (default)	<p>Sets how to process areas surrounded by the specified color. If [Yes] is set, those areas are processed as the specified color.</p> <p>Input Image → Filled Image</p> 
Extract image	Yes No (default)	<p>Select this option if there are areas of the specified color inside the measurement region that you do not want to measure. If [Yes] is set, all areas outside the measurement region are cut out as the specified color.</p> <p>Measurement region → Yes</p>  <p>You need to know the position and area of this label.</p> <p>You can find the position and area of the center label if you set the sort condition to sort by descending order of area. Areas outside the measurement region are set to the color for measurement.</p>

## Changing the Label Extraction Conditions

Set the label extraction conditions. You can select to extract only labels that satisfy all four of the following: Number of labels, specified area, gravity X, and gravity Y conditions.

► **[Inspect] – [Inspection] – [Labeling] – [Modify] – [Settings] Details – [Details] Tab Page – [Meas. Parameter] – [Extraction condition]**

- 1 Press and set each of the parameters for the extraction conditions.

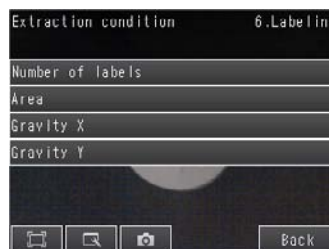

Item	Parameter	Setting	Description
Extraction condition	Number of labels	Range: 1 to 100 Default: 100	Set the maximum number of labels to detect.
	Area	Range: 0 to 999,999,999.9999 Defaults: Upper limit: 999,999,999.9999, Lower limit: 0	Specify the area range to judge as a label.
	Gravity X	Range: -99,999,999.9999 to 999,999,999.999 Defaults: Upper limit: 999,999,999.999, Lower limit: -999,999,999.9999	Specify the gravity X position to judge as a label.
	Gravity Y	Range: -999,999,999.9999 to 999,999,999.999 Defaults: Upper limit: 999,999,999.999, Lower limit: -999,999,999.9999	Specify the gravity Y position to judge as a label.

## Sorting Extracted Labels

Set the sort condition and count for extracted labels. You can set the sort condition and the maximum number of detections for detection results.

► **[Inspect] – [Inspection] – [Labeling] – [Modify] – [Details] Tab Page – [Meas. Parameter]**

- 1 Press **[Sorting method]**.
- 2 Select the sorting method.



Item	Parameter	Setting	Description
Measurement parameter	Sorting method	Area ascending order Area descending order Pos. X ascending order (ascending order of X coordinate) (default) Pos. X descending order (descending order of X coordinate) Pos. Y ascending order (ascending order of Y coordinate) Pos. Y descending order (descending order of Y coordinate)	Set the condition to use for label number reassignment. When sorting by X or Y coordinates, the upperleft corner is the origin.

## Reflect in Total Judgement

You can specify whether to reflect the judgement results of an inspection item in the overall judgement. (The default is to reflect them.)

► [Inspect] – [Inspection] – [Add item.] – [Labeling] – [Details] Tab Page – [Output parameter]

## Editing the Measurement Region

This section describes how to edit the measurement regions. You can edit the measurement region in the same way as for a search region.

📖 Changing the Model Registration Region to a Shape Other Than a Rectangle: p. 100

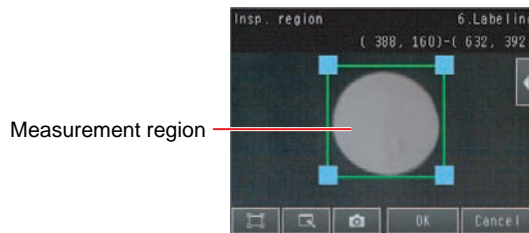

### Important

If the measurement region is changed, perform teaching if required.

📖 p. 147

## Increasing the Processing Speed

Make the measurement region smaller to reduce the processing time.

 Changing the Measurement Region p. 102

## Measurement Data That Can Be Used for External Outputs and Calculations

The following values can be used as measurement data and output to external devices via the Ethernet or used in calculations.

Expression text string	Data name	Description	Data range
JG	Judgement	This is the Labeling judgement results.	-2: No judgement (not measured), 0: Judgement is OK, -1: Judgement is NG, -13: Teaching not performed error, -14: Figure not registered error, -15: Out of range error
L	Number of labels	This is the number of labels found.	0 to 100
TAR	Total label area	This is the total area of all labels found.	0 to 999,999,999.9999
AR[0] to AR[99]	Area	These are the areas of each individual label.	0 to 999,999,999.9999
X[0] to X[99]	Gravity X	These are the X coordinates of the center of each label.	-99,999.9999 to 99,999.9999
Y[0] to Y[99]	Gravity Y	These are the Y coordinates of the center of each label.	-99,999.9999 to 99,999.9999
ATH[0] to ATH[99]	Master angle	These are the master angle of the center of each label.	-180 to 180
SA	Reference area	This is the reference area.	0 to 999,999,999.9999
SX	Ref. position X (reference position X)	This is the X coordinate of the reference position.	-99,999.9999 to 99,999.9999
SY	Ref. position Y (reference position Y)	This is the Y coordinate of the reference position.	-99,999.9999 to 99,999.9999

 4-13 Calculations and Judgements Using Inspection Item Data p. 155

## Measurement Data That Can Be Logged for Labeling

You can select to log any of the following values.

Measurement item	Range of value	Description
Judgement	0: Judgement is OK -1: Judgement is NG -13: Teaching not performed error -14: Figure not registered error -15: Out of range error	This is the measurement judgement results.
Number of labels	0 to 100	This is the number of labels.
Total label area	0 to 999,999,999.9999	This is the total area of all extracted labels.
Area	0 to 999,999,999.9999	This is the area of the detected label (100 max.).
Gravity center X	-99999.9999 to 99999.9999	This is the gravity coordinate X of the detected label (100 max.).
Gravity center Y	-99999.9999 to 99999.9999	This is the gravity coordinate Y of the detected label (100 max.).
Master angle	-180 to 180	This is the master angle of the detected label (100 max.).

\* When logging data is output, the data is output in the order of the above table.  
If more than one item is stored, results are output in order for each label.

Example:

[# of label] [Total label area] [Area 0.X] [Area 0.Y] [Gravity center 0.X] [Gravity center 0.Y] [Master angle 0.ATH]  
... [Area N.X] [Area N.Y] [Gravity center N.X] [Gravity center N.Y] [Master angle N.ATH] ... [Number of Label  
(Count-1).X] [Number of Label (Count-1).Y] [Number of Label (Count-1).TH]



7-6 Logging Measurement Data and Image Data p. 208

## Errors

### Errors in Teaching

A teaching error message will appear if the reference area registered during teaching is 0. Perform the following.

- If the color of the measurement object has changed from the specified color, set the color again and try teaching again.



## 4-13 Calculations and Judgements Using Inspection Item Data

You can set inspection item judgement results and measurement data with the Calculation menu command to use them in basic arithmetic operations and functions. The judgement results of the calculations are reflected in the overall judgement.

### Calculation

Use the Calculation menu command to set the calculation expressions and the judgement parameters for the calculation results.

### Expression

You can get up to 32 expressions. You can also combine expressions.

You can use the following values in calculations.

- Filter item and position compensation item data (measurement data, reference values, and judgement results)
- Inspection item data (measurement data, reference values, and judgement results)
- Constants
- Other calculation results

### Judgement

Upper and lower limit values are used for the judgement of calculation results (D0 to D31). Each calculation judgement result (J0 to J31) is turned ON if the result falls within the upper and lower limits. The OR logic of these results will be the overall judgement result JG.

You can reflect the judgement results (JG) of the calculations in the overall judgement. (You can also set the output parameters so that the judgement results are not reflected in the overall judgement.)

## Outputting the Calculation Results

The overall judgement (JG) of the calculations are reflected in the overall judgement of the inspection item. The calculation results (D0 to 31) can be output as Ethernet outputs or it can be output by using logging.

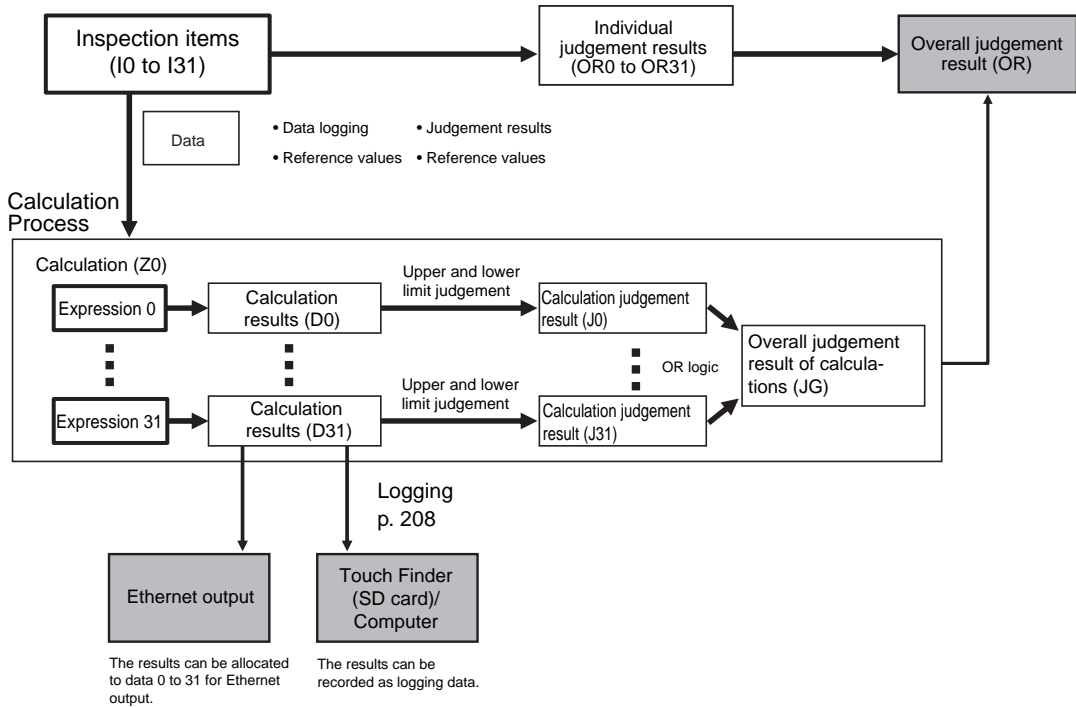

## Examples for Calculation

### Finding the Distance between Two Measured Points

This example finds edge position 2 by detecting the two edge positions of inspection item 0 and inspection item 1, and calculates the distance between the two points.

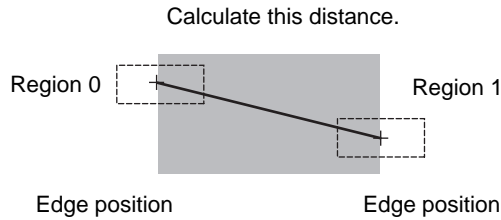

- Region 0 (edge position coordinates of inspection item 0): (I0.X,I0.Y)
- Region 1 (edge position coordinates of inspection item 1): (I1.X,I1.Y)
- Distance between two points = DIST (I0.X,I0.Y,I1X,I1.Y)

### Procedure (Calculation)

- 1 Press [Inspect] – [Calculation].

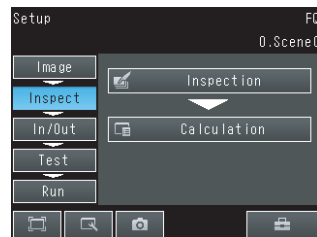

### Setting Expressions

- 1 Press [Expression] on the [Settings] Tab Page.

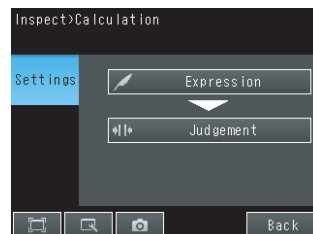

- 2 Press the expression number that you want to use.

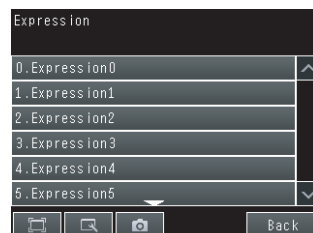

### 3 Press [Modify] on the menu.

#### Note

#### Performing Similar Calculations At Different Locations

- [Rename] The name of the calculation can be changed. (16 characters max.)
- [Copy] Previously registered calculation expressions can be copied.



### 4 Set the expression by selecting items from the [Data], [Const.], and [Math.] Tab Pages.

The expression will be displayed in the space under [Expression settings].

Do not exceed 255 characters in the expression.

Item	Description
Const.	Press this to input constants or a mathematical operator. The following operators can be used: + (addition), - (subtraction), × (multiplication), and / (division).
Data	Press this to use measurement data, reference values, and judgement results of other items.
Math.	Press this to use functions.

## Expression Notation

Expressions must have the following notation.

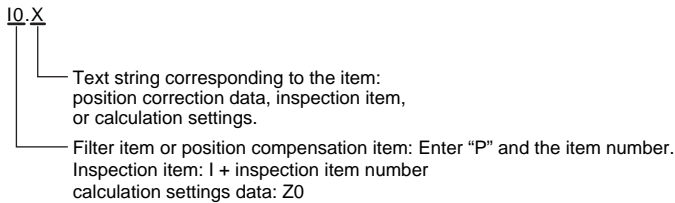

Example: Finding the distance between the centers of gravity of inspection item 1 and inspection item 2 using a function.

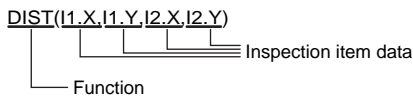

Example: Subtracting 120 from the calculation result of expression 0.

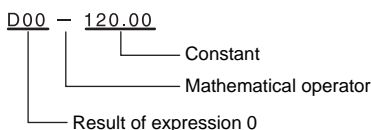

Example: Adding the judgement result of inspection items 0 and 1.

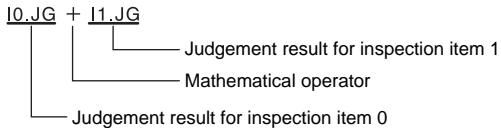

## Function List

The following functions can be used in calculations.

Function	Description
SIN	Finds the sine. The result is a value between $-1$ and $1$ . The angle in the expression is in degrees. $SIN(angle)$
COS	Finds the cosine. The result is a value between $-1$ and $1$ . The angle in the expression is in degrees. $COS(angle)$
ATAN	Finds the arctangent of the value (Y component, X component). The result is a radian value between $-\pi$ and $\pi$ . $ANGL(Y\_component, X\_component)$ Example: Finding the angle between the straight line joining the centers of region 0 and region 1 and horizontal. $ATAN(R1.Y-R0.Y, R1.X-R0.X)$ If the two arguments are both 0, the result is 0 and the judgement is NG.
AND	Finds the logical AND. If one of the arguments is 0, the calculation result is 0. Otherwise it is $-1$ . $AND(argument\_1, argument\_2)$
OR	Finds the logical OR. If both of the arguments are 0, the calculation result is 0. Otherwise it is $-1$ . $OR(argument\_1, argument\_2)$
NOT	Applies a logical NOT operation. If the argument is 0, the calculation result is $-1$ . Otherwise it is 0. $NOT(argument)$
ABS	Finds the absolute value. $ABS(argument)$
MAX	Returns the larger of the two arguments. $MAX(argument\_1, argument\_2)$
MIN	Returns the smaller of the two arguments. $MAX(argument\_1, argument\_2)$

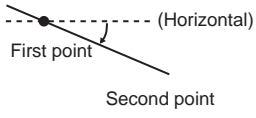
Function	Description
ANGL	<p>Finds the angle of the straight line joining two points (the center of gravity and center of the model). The angle against the horizontal is found. The result is a value between -180 and 180.</p> <p><i>ANGL(Y_component, X_component)</i></p> <p>Example: Finding the angle of the straight line joining the centers of region 0 and region 1</p> <p><i>ANGL(R1.Y-R0.Y, R1.X-R0.X)</i></p>  <p>If the two arguments are both 0, the result is 0 and the judgement is NG.</p>
MOD	<p>Finds the remainder after dividing a non-ordinal number with an ordinal number.</p> <p><i>MOD(non-ordinal, ordinal)</i></p> <p>If any of the arguments are real numbers, the decimals are rounded off before calculating the remainder. The remainder is the result of dividing integers.</p> <p>Example: <i>MOD(13,4)</i> ... Result: 1 (remainder when 13 is divided by 4)</p> <p><i>MOD(25.68,6.99)</i> ... Result: 5 (remainder when 26 is divided by 7)</p>
SQRT	<p>Finds the square root.</p> <p>If the argument is negative, the result is 0. The judgement will be NG.</p> <p><i>SQRT(argument)</i></p>
DIST	<ul style="list-style-type: none"> <li>Finds the distance between two points (the center of gravity and the center of the model).</li> </ul> <p><i>DIST(first_position_X, first_position_Y, second_position_X, second_position_Y)</i></p> <p>Example: Finding the distance between the centers of gravity of region 0 and region 1</p> <p><i>DIST(R0.X, R0.Y, R1.X, R1.Y)</i></p> <p>The following calculation is performed internally.</p> $\sqrt{(R1.X-R0.X)^2+(R1.Y-R0.Y)^2}$ <ul style="list-style-type: none"> <li>Finds the length of a perpendicular line from point (x,y) to line <math>ax + by + c = 0</math>.</li> </ul> <p><i>DIST(X_coordinate_of_point, Y_coordinate_of_point, coefficient_a_of_line, coefficient_b_of_line, coefficient_c_of_line)</i></p>

## Setting Judgement Parameters for Expressions

1 Press [Judgement] on the [Settings] Tab Page.

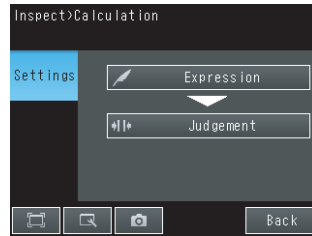

2 Press an expression between 0 to 31 and set the corresponding judgement parameters using the slider.

3 Press the [OK] Button.

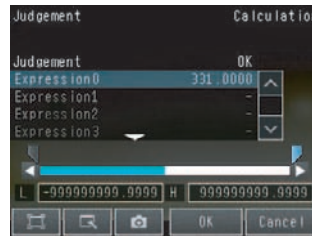

## Reflecting the Judgement Results for Expressions to the Overall Judgement Results

You can specify whether to reflect the judgement results of a calculation in the overall judgement. (The default is to reflect them.)

► [Inspect] – [Calculation] – [Details] Tab Page – [Output parameter] – [Reflect]

## Inspection Item Data That Can Be Used in Expressions

Inspection item	Data name	Expression text string	Data range	Default
Filter	Judgement	JG	-2: No judgement (not measured) 0: Judgement is OK -1: Judgement is NG	-2
Shape Sear. pos. comp.	Judgement	JG	-2: No judgement (not measured) 0: Judgement is OK -1: Judgement is NG	-2
	Scroll X	DX	-99999.9999 to 99999.9999	0
	Scroll Y	DY	-99999.9999 to 99999.9999	0
	Scroll $\theta$	DT	-180 to 180	0
	Position X	X	-99999.9999 to 99999.9999	0
	Position Y	Y	-99999.9999 to 99999.9999	0
	Angle	TH	-180 to 180	0
	Reference X	SX	-99999.9999 to 99999.9999	0
	Reference Y	SY	-99999.9999 to 99999.9999	0
	Reference angle	ST	-180 to 180	0
Correlation	CR	0 to 100	0	
Search position comp.	Judgement	JG	-2: No judgement (not measured) 0: Judgement is OK -1: Judgement is NG	-2
	Scroll X	DX	-99999.9999 to 99999.9999	0
	Scroll Y	DY	-99999.9999 to 99999.9999	0
	Position X	X	-99999.9999 to 99999.9999	0
	Position Y	Y	-99999.9999 to 99999.9999	0
	Reference X	SX	-99999.9999 to 99999.9999	0
	Reference Y	SY	-99999.9999 to 99999.9999	0
	Correlation	CR	0 to 100	0
Edge position comp.	Judgement	JG	-2: No judgement (not measured) 0: Judgement is OK -1: Judgement is NG	-2
	Scroll X	DX	-99999.9999 to 99999.9999	0
	Scroll Y	DY	-99999.9999 to 99999.9999	0
	Ref. position X	X	-99999.9999 to 99999.9999	0
	Ref. position Y	Y	-99999.9999 to 99999.9999	0
	Reference X	SX	-99999.9999 to 99999.9999	0
	Reference Y	SY	-99999.9999 to 99999.9999	0



Inspection item	Data name	Expression text string	Data range	Default
2Edge position comp.	Judgement	JG	-2: No judgement (not measured) 0: Judgement is OK -1: Judgement is NG	-2
	Scroll X	DX	-99999.9999 to 99999.9999	0
	Scroll Y	DY	-99999.9999 to 99999.9999	0
	Edge0 position X	X0	-99999.9999 to 99999.9999	0
	Edge0 position Y	Y0	-99999.9999 to 99999.9999	0
	Edge1 position X	X1	-99999.9999 to 99999.9999	0
	Edge1 position Y	Y1	-99999.9999 to 99999.9999	0
	Edge0 ref. position X (edge 0 reference position X)	SX0	-99999.9999 to 99999.9999	0
	Edge0 ref. position Y (edge 0 reference position Y)	SY0	-99999.9999 to 99999.9999	0
	Edge1 ref. position X (edge 1 reference position X)	SX1	-99999.9999 to 99999.9999	0
	Edge1 ref. position Y (edge 1 reference position Y)	SY1	-99999.9999 to 99999.9999	0
2Edge midpoint comp.	Judgement	JG	-2: No judgement (not measured) 0: Judgement is OK -1: Judgement is NG	-2
	Scroll X	DX	-99999.9999 to 99999.9999	0
	Scroll Y	DY	-99999.9999 to 99999.9999	0
	Edge0 position X	X0	-99999.9999 to 99999.9999	0
	Edge0 position Y	Y0	-99999.9999 to 99999.9999	0
	Edge1 position X	X1	-99999.9999 to 99999.9999	0
	Edge1 position Y	Y1	-99999.9999 to 99999.9999	0
	Midpoint X	MX	-99999.9999 to 99999.9999	0
	Midpoint Y	MY	-99999.9999 to 99999.9999	0
	Edge0 ref. position X (edge 0 reference position X)	SX0	-99999.9999 to 99999.9999	0
	Edge0 ref. position Y (edge 0 reference position Y)	SY0	-99999.9999 to 99999.9999	0
	Edge1 ref. position X (edge 1 reference position X)	SX1	-99999.9999 to 99999.9999	0
	Edge1 ref. position Y (edge 1 reference position Y)	SY1	-99999.9999 to 99999.9999	0
	Ref. midpoint X (reference midpoint X)	SMX	-99999.9999 to 99999.9999	0
Ref. midpoint Y (reference midpoint Y)	SMY	-99999.9999 to 99999.9999	0	

Inspection item	Data name	Expression text string	Data range	Default
Edge rot. pos. Comp.	Judgement	JG	-2: No judgement (not measured) 0: Judgement is OK -1: Judgement is NG	-2
	Scroll $\theta$	DT	-180 to 180	0
	Edge0 position X	X0	-99999.9999 to 99999.9999	0
	Edge0 position Y	Y0	-99999.9999 to 99999.9999	0
	Edge1 position X	X1	-99999.9999 to 99999.9999	0
	Edge1 position Y	Y1	-99999.9999 to 99999.9999	0
	Angle	TH	-180 to 180	0
	Edge0 ref. position X (edge 0 reference. position X)	SX0	-99999.9999 to 99999.9999	0
	Edge0 ref. position Y (edge 0 reference. position Y)	SY0	-99999.9999 to 99999.9999	0
	Edge1 ref. position X (edge 1 reference. position X)	SX1	-99999.9999 to 99999.9999	0
	Edge1 ref. position Y (edge 1 reference. position Y)	SY1	-99999.9999 to 99999.9999	0
Reference angle	STH	-180 to 180	0	
Search	Judgement	JG	-2: No judgement (not measured) 0: Judgement is OK -1: Judgement is NG -13: Teaching not performed error -14: Figure not registered error -15: Out of range error	-2
	Correlation	CR[0] to CR[31]	0 to 100	0
	Position X	X[0] to X[31]	-99999.9999 to 99999.9999	0
	Position Y	Y[0] to Y[31]	-99999.9999 to 99999.9999	0
	Angle	TH[0] to TH[31]	-180 to 180	0
	Reference X	SX	-99999.9999 to 99999.9999	0
	Reference Y	SY	-99999.9999 to 99999.9999	0
	Reference angle	ST	-180 to 180	0
	Detection X	RX	-99999.9999 to 99999.9999	0
	Detection Y	RY	-99999.9999 to 99999.9999	0
Count	C	0 to 32	0	
Shape Search II	Judgement	JG	-2: No judgement (not measured) 0: Judgement is OK -1: Judgement is NG -13: Teaching not performed error -14: Figure not registered error -15: Out of range error	-2
	Correlation	CR	0 to 100	0
	Position X	X	-99999.9999 to 99999.9999	0
	Position Y	Y	-99999.9999 to 99999.9999	0
	Angle	TH	-180 to 180	0
	Reference X	SX	-99999.9999 to 99999.9999	0
	Reference Y	SY	-99999.9999 to 99999.9999	0
	Reference angle	ST	-180 to 180	0
	Detection X	RX	-99999.9999 to 99999.9999	0
	Detection Y	RY	-99999.9999 to 99999.9999	0
Count	C	0 to 32	0	

Inspection item	Data name	Expression text string	Data range	Default
Sensitive Search	Judgement	JG	-2: No judgement (not measured) 0: Judgement is OK -1: Judgement is NG -13: Teaching not performed error -14: Figure not registered error -15: Out of range error	-2
	Correlation	CR	0 to 100	0
	Density	DV	0 to 221	0
	Position X	X	-99999.9999 to 99999.9999	0
	Position Y	Y	-99999.9999 to 99999.9999	0
	Angle	TH	-180 to 180	0
	Detection X	RX	-99999.9999 to 99999.9999	0
	Detection Y	RY	-99999.9999 to 99999.9999	0
	Ref. position X (reference position X)	SX	-99999.9999 to 99999.9999	0
	Ref. position Y (reference position Y)	SY	-99999.9999 to 99999.9999	0
	Reference angle	ST	-180 to 180	0
	NG sub-region	CT	0 to 100	0
	Sub-region number	AN	1 to 99	0
	Sub-region number(X)	ANX	0 to 9	0
	Sub-region number(Y)	ANY	0 to 9	0
	Sub-region pos.X (sub-region position X)	DX	-99999.9999 to 99999.9999	0
	Sub-region pos.Y (sub-region position Y)	DY	-99999.9999 to 99999.9999	0
	Correlation (sub-region)	CRN[0] to CRN[80]	0 to 100	0
Deviation (sub-region)	DVN[0] to DVN[80]	0 to 221	0	
Edge Position	Judgement	JG	-2: No judgement (not measured) 0: Judgement is OK -1: Judgement is NG -13: Teaching not performed error -14: Figure not registered error -15: Out of range error	-2
	Position X	X	-99999.9999 to 99999.9999	0
	Position Y	Y	-99999.9999 to 99999.9999	0
	Ref. position X (reference position X)	SX	-99999.9999 to 99999.9999	0
	Ref. position Y (reference position Y)	SY	-99999.9999 to 99999.9999	0
	Offset amount	DF	-99999.9999 to 99999.9999	0
Edge width	Judgement	JG	-2: No judgement (not measured) 0: Judgement is OK -1: Judgement is NG -13: Teaching not performed error -14: Figure not registered error -15: Out of range error	-2
	D. edge width	DF	0 to 99999.9999	0
	Ref. edge width	SW	0 to 99999.9999	0
	Edge width	W	0 to 99999.9999	0

Inspection item	Data name	Expression text string	Data range	Default
Edge Pitch	Judgement	JG	-2: No judgement (not measured) 0: Judgement is OK -1: Judgement is NG -13: Teaching not performed error -14: Figure not registered error -15: Out of range error	-2
	Edge pitch	N	0 to 999	0
	Average pitch	P	0 to 99999.9999	0
	Max. pitch (maximum pitch)	PH	0 to 99999.9999	0
	Min. pitch (minimum pitch)	PL	0 to 99999.9999	0
	Average width	W	0 to 99999.9999	0
	Max width (maximum width)	WH	0 to 99999.9999	0
	Min width (minimum width)	WL	0 to 99999.9999	0
Color Data	Judgement	JG	-2: No judgement (not measured) 0: Judgement is OK -1: Judgement is NG -13: Teaching not performed error -14: Figure not registered error -15: Out of range error	-2
	R average	AR	0 to 255	0
	G average	AG	0 to 255	0
	B average	AB	0 to 255	0
	Color diff./dens. Av. (color difference/density average)	AD	Color difference: 0 to 442 Density average: 0 to 255	0
	Clr deviat. (color deviation/density deviation)	DV	Color difference: 0 to 221 Density deviation: 0 to 217	0
Area	Judgement	JG	-2: No judgement (not measured) 0: Judgement is OK -1: Judgement is NG -13: Teaching not performed error -14: Figure not registered error -15: Out of range error	-2
	Area	AR	0 to 999999999.9999	0
	Gravity X	X	-99999.9999 to 99999.9999	0
	Gravity Y	Y	-99999.9999 to 99999.9999	0
	Reference area	SA	0 to 999999999	0
	Ref. position X (reference position X)	SX	-99999.9999 to 99999.9999	0
	Ref. position Y (reference position Y)	SY	-99999.9999 to 99999.9999	0

Inspection item	Data name	Expression text string	Data range	Default
Labeling	Judgement	JG	-2: No judgement (not measured) 0: Judgement is OK -1: Judgement is NG -13: Teaching not performed error -14: Figure not registered error -15: Out of range error	-2
	Number of labels	L	0 to 100	0
	Area	AR[0] to AR[99]	0 to 999999999.9999	0
	Gravity X	X[0] to X[99]	-99999.9999 to 99999.9999	0
	Gravity Y	Y[0] to Y[99]	-99999.9999 to 99999.9999	0
	Reference area	SA	0 to 999999999.9999	0
	Ref. position X (reference position X)	SX	-99999.9999 to 99999.9999	0
	Ref. position Y (reference position Y)	SY	-99999.9999 to 99999.9999	0
	Total label area	TAR	0 to 999999999.9999	0
	Master angle	ATH[0] to ATH[99]	-180 to 180	0

The following values can be specified as calculation data to output them.

Data name	Expression text string	Description
Judgement	JG	This is the judgement result. It is the OR logic of the judgement results of all expressions.
Judgement 0	J00	This is the judgement results of expression 0.
Judgement 1	J01	This is the judgement results of expression 1.
:	:	:
Judgement 31	J31	This is the judgement results of expression 31.
Data 0	D00	This is the result of expression 0.
Data 1	D01	This is the result of expression 1.
Data 2	D02	This is the result of expression 2.
Data 3	D03	This is the result of expression 3.
Data 4	D04	This is the result of expression 4.
Data 5	D05	This is the result of expression 5.
Data 6	D06	This is the result of expression 6.
Data 7	D07	This is the result of expression 7.
Data 8	D08	This is the result of expression 8.
Data 9	D09	This is the result of expression 9.
Data 10	D10	This is the result of expression 10.
Data 11	D11	This is the result of expression 11.
Data 12	D12	This is the result of expression 12.
Data 13	D13	This is the result of expression 13.
Data 14	D14	This is the result of expression 14.
Data 15	D15	This is the result of expression 15.
Data 16	D16	This is the result of expression 16.
Data 17	D17	This is the result of expression 17.
Data 18	D18	This is the result of expression 18.
Data 19	D19	This is the result of expression 19.
Data 20	D20	This is the result of expression 20.
Data 21	D21	This is the result of expression 21.
Data 22	D22	This is the result of expression 22.
Data 23	D23	This is the result of expression 23.
Data 24	D24	This is the result of expression 24.

Data name	Expression text string	Description
Data 25	D25	This is the result of expression 25.
Data 26	D26	This is the result of expression 26.
Data 27	D27	This is the result of expression 27.
Data 28	D28	This is the result of expression 28.
Data 29	D29	This is the result of expression 29.
Data 30	D30	This is the result of expression 30.
Data 31	D31	This is the result of expression 31.

## Measurement Data That Can Be Logged

The following values can be logged as measurement data.

Parameter	Setting	Description
J00 to J31	-2: No judgement (not measured), 0: Judgement is OK, -1: Judgement is NG	This are the judgement results of expressions 0 to 31.
Results 0 to 31	-999999999.9999 to 999999999.9999	This is the results of expressions 1 to 31.

# Testing and Saving Settings

---

5-1 Performing Test Measurements.....	170
5-2 Shortening the Measurement Takt Time.....	172
5-3 Adjusting the Judgement Parameters.....	175
5-4 Checking a List of All Inspection Item Results .....	177
5-5 Saving Data to the Sensor.....	178

# 5-1 Performing Test Measurements

After completing the settings in the [Image], [Inspect], and [In/Out] Tab Pages, move to the [Test] Tab Page. The displayed image is measured automatically. This is called a test measurement. A test measurement is used to verify that the settings that have been made will produce stable results and, if necessary, to fine-tune the settings. An overall judgement of all inspection items can be performed. Test measurements can be performed for through images (default) or saved images.

## Performing Test Measurements with Samples

### ► [Test] – [Continuous test]

- 1 Press [Graphics+Details].
- 2 Input an image of a previously prepared object. Check the judgement results.
- 3 When you finish checking the results, press [Back].



### Note

The same five types of displays are available for the [Continuous test] on the [Test] Tab Page, i.e., [Graphics], [Graphics + Details], [All results/region], [Trend monitor], and [Histogram]. Press the [Back] Button to access the menu to change the display.

 Changing the Run Mode display: p. 182

## Performing Test Measurements with Saved Images (Re-measuring)

This Sensor can save measured images in the Sensor's built-in memory or on an SD card. Test measurements can be performed using these saved images. This function is useful for adjusting the judgement parameters when objects are not available.

### ► [Test] – [Continuous test] – (Any display)

- 1 Press  – .





## 2 Select one of the following.

- [Log]: Images that are logged in the Sensor's internal memory.
- [Logging image file]: Images that are logged in the SD card.
- [Camera image file]: Images that were saved as logged images with the  (Log Image) Button.



## 3 The display switches to the saved image and measurements are taken again.

 Saving images: p. 227



# 5-2 Shortening the Measurement Takt Time

## Checking the Measurement Takt Time

The measurement time of this Sensor can be checked from the Setup or Run Mode display.

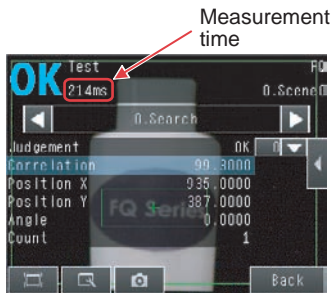

The measurement time is the time taken from when a trigger is input until when all measurement processes are executed.

During the measurement time, this Sensor will not accept the next trigger. This means that the measurement time is the basic measurement takt time.

Inputting a trigger

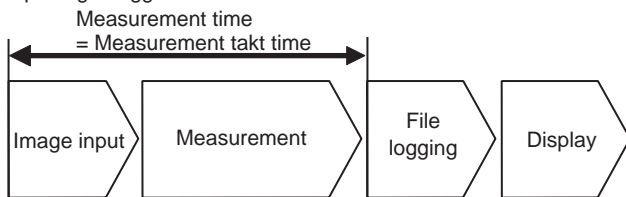

## Increasing Image Input Speed

With the partial input function, it is possible to input only images that are in the region that is necessary for measurements.

The image measurement region becomes smaller and therefore the image input time is shortened.

Consider the offset in the measurement object when you set the range.

The image in the input range will be displayed in the inspection item setting displays and measurement displays.

### ► [Image] – [Camera setup]

- 1 Press [◀] – [Partial input] on the right side of the display.
- 2 Press [Y] and set the input range along the Y axis by setting the Y coordinate of the partial input start point and the Y coordinate of the partial input end point.
- 3 Press [X] and set the input range along the X axis by setting the X coordinate of the partial input start point and the X coordinate of the partial input end point.
- 4 Press [OK].

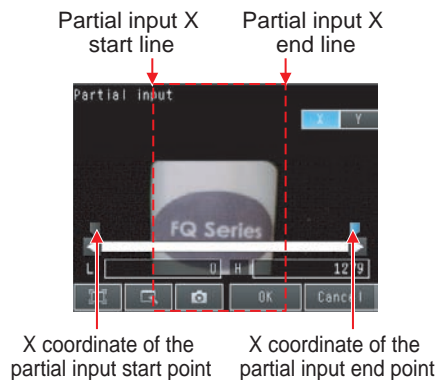
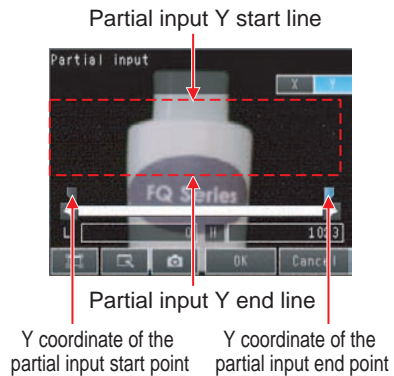

Parameter	Setting	Description
X coordinate of the partial input start point	Range: 0 to 1,267 Default: 0	Specify the partial input range along the X axis.
X coordinate of the partial input end point	Range: 15 to 1,279 Default: 1,279	
Y coordinate of the partial input start point	<ul style="list-style-type: none"> <li>• FQ-S□□□□□□□□ Range: 0 to 472, Default: 0</li> <li>• FQ-S□□□□□□□□-08□ Range: 0 to 820, Default: 0</li> <li>• FQ2-S3□-□□□□ Range: 0 to 1,016, Default: 0</li> </ul>	Specify the partial input range along the Y axis.
Y coordinate of the partial input end point	<ul style="list-style-type: none"> <li>• FQ-S□□□□□□□□ Range: 7 to 479, Default: 0</li> <li>• FQ-S□□□□□□□□-08□ Range: 7 to 827, Default: 0</li> <li>• FQ2-S3□-□□□□ Range: 7 to 1,023, Default: 0</li> </ul>	

**Note**

- The minimum input widths are 16 for the X axis and 8 for the Y axis.
- The values of the monitor display positions are displayed for the coordinates in the measurement results.
- The coordinate values will not change as a result of the partial input settings.

**Important**

If you use partial input, perform teaching again. Partial input on the X axis is supported only by the FQ2-S3□-□□□.

## Changing the Image Input Mode

Pixel sampling can be applied to the input image to reduce image input time.

▶ **[Image]** – **[Camera setup]** – ◀ – **[Image input mode]**

Parameter	Setting	Description
Image Input Mode	High-speed or Standard Default for FQ2-S1 or FQ2-S2: High-speed, Default for FQ2-S3: Standard	Pixel sampling can be applied to the input image to reduce image input time.

**Important**

If you change the image input mode, perform teaching again.

# 5-3 Adjusting the Judgement Parameters

## Adjusting Judgement Parameters While Looking at Measurement Results

If correct judgements are not possible, you can move directly from the Setup Mode display to the judgement parameters display to make adjustments.

► [Test] – [Continuous test] – (Either display)

- 1 Press [◀] – [Adjust judgement] on the right of the display.
- 2 Press the parameters and adjust the values of the judgment conditions for them.

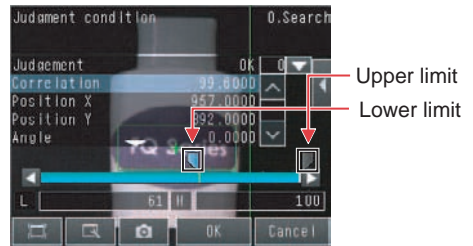

## Setting Up the Best Judgement Parameters Automatically

The judgement parameters of the selected inspection items can be automatically adjusted by using actual workpieces which are considered as good and faulty products.

► [Test] – [Continuous test]

- 1 Move to the inspection item for which you want to automatically adjust the judgement parameters and press [◀] – [Adjust judgement] on the right side of the display.
- 2 Press [◀] – [Auto adjustment].
- 3 Display a sample image of a good object and press [OK Teach]. Display a sample image of a bad object and press [NG Teach].

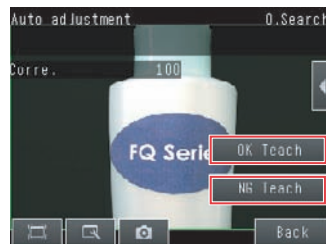

- 4 Repeat these steps for at least three samples each.
- 5 Press [Back].  
The best judgement parameters will be set automatically.
- 6 Press [OK].

**Note**

You can select one of the following three patterns as the judgement method.

► [◀] – [Select the method.] on the right side of the display

- 1) Threshold (minimum): The lower limit of the variations between OK object is used as the judgement condition.
- 2) Threshold (average): The median value between the OK object variations and NG object variations is used as the judgement condition.
- 3) Threshold (maximum): The upper limit of the variations between NG object is used as the judgement condition.

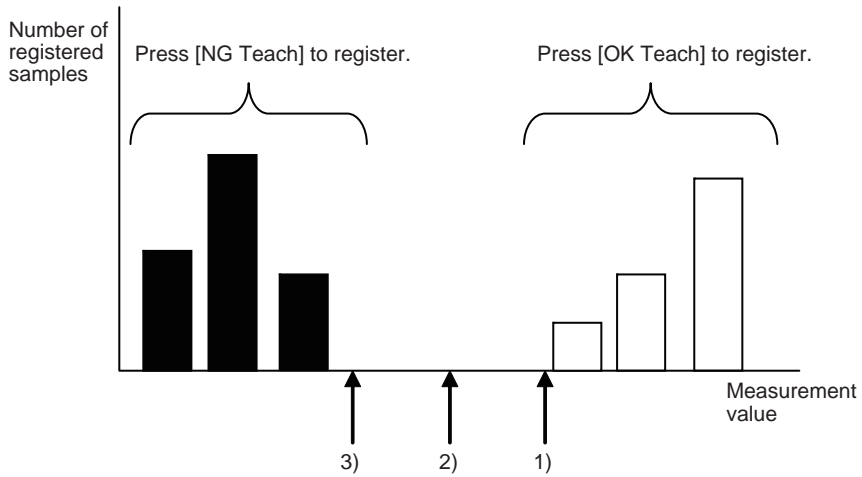

# 5-4 Checking a List of All Inspection Item Results

Individual judgement results for all inspection items can be checked in a list. The individual inspection items can be selected to change the judgement parameters.

► [Test] – [Continuous test]

1 Press [All results/region] to display the list.



**Note**

Judgement parameters can also be changed from this display. Select an inspection item and press [◀] – [Adjust judgement].

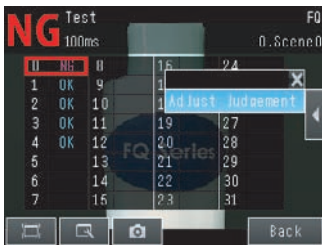

## 5-5 Saving Data to the Sensor

Until you have saved your settings explicitly to the memory in the FQ2 Vision Sensor, the settings are only stored temporarily. They will be lost if the power is turned OFF. Execute [Save data] after you have finished making your settings. The FQ2 Vision Sensor will remind you to do so with a message if you switch from Setup Mode to Run Mode. You can use this feature to keep the previous settings and discard the new settings if desired, but keep in mind that all settings that are not saved explicitly are replaced by the settings that are stored in the memory of the FQ2 Vision Sensor the next time you turn ON the FQ2 Vision Sensor.

### Important



Do not turn the power supply OFF while data is being saved. The data that is being saved may become corrupted.

### ► [Test]

- 1 Press [Save data].
- 2 Press [Yes].



### Note

- Scene data and system data can be saved in this way.  
 Scene data and system data details: p. 218
- Measurement data and image data cannot be saved in this way.  
 Logging measurement data: p. 209
- Settings data can also be backed up to an external memory.  
 Saving settings: p. 218



# Operation

---

<b>6-1 Starting Operation.....</b>	<b>180</b>
<b>6-2 Configuring the Run Mode Display.....</b>	<b>182</b>
<b>6-3 Checking the Trend of Measurement Results with Graphs.....</b>	<b>184</b>
<b>6-4 Adjusting Judgement Parameters during Operation.....</b>	<b>187</b>

# 6-1 Starting Operation

When test measurements and adjustments in Setup Mode have been finished, change to Run Mode and begin actual measurements. In Run Mode, the Sensor operates stand-alone and outputs the measurement judgement results on the I/O lines accordingly to the settings. If the Touch Finder or the PC Tool is connected via network to the Sensor, the operation of the Sensor can be monitored in the following ways.

## Run Mode Display

The present display name.

Overall judgement

Measurement processing time  
The time taken from when an image is input until all measurements have been completed.

Inspection results can be displayed in six formats, such as in a list or as a trend graph. p. 182

These buttons are displayed both in Setup and Run Mode. p. 22

Selected inspection item

Connected Sensor name

Selected scene number

Sub-menu

Used to select the detection information to display when more than one detection point is detected at the same time for one item.

Tool Button or OK Button

## Moving to Run Mode

You can move from Setup Mode to Run Mode by using the following procedure.

- 1 Press [Run].**
- 2 Press [Switch to Run mode.].**
- 3 Press [Yes].**  
If you press [No], the setting will not be saved and you will move to Run Mode.

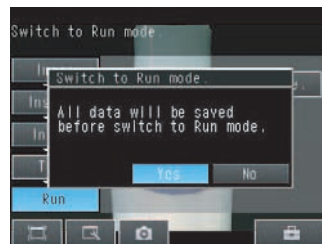
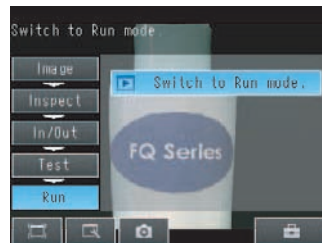

**Note**

- Returning to Setup Mode

Press  and press [Sensor settings].

- Signal Status When Moving to Run Mode

When moving to Run Mode, the signal will change as shown below and data can be input from and output to an external device.

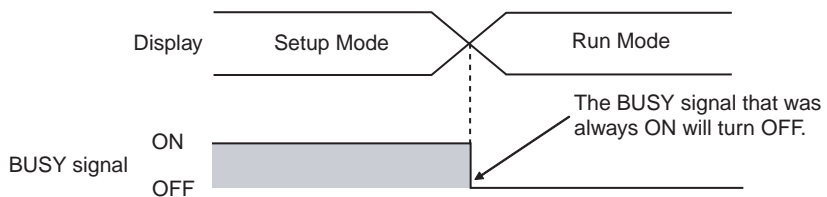

# 6-2 Configuring the Run Mode Display

There are six types of displays that can be used, as shown below. Select the display as desired.

### Checking the Judgement Results of Inspection Items



The image and region currently being measured will appear.

### Graphics + Details

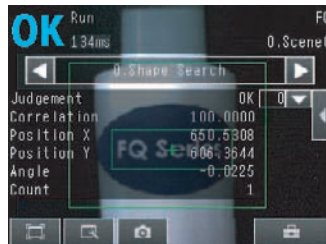

In addition to [Graphics] display, individual judgement results and measurement values of selected inspection items will appear.

### Checking the Overall Judgement Result History

#### Statistical data



The currently measured image and history of the overall judgement results (measurement count, NG count, and NG rate) will appear.

### Checking the Judgements of All Inspection Items in a List

All results/region  
(Standard Models and High-resolution Models Only)



The judgement results of all inspection items can be checked in a list.

### Displaying Measurement Result Histories

#### Trend monitor

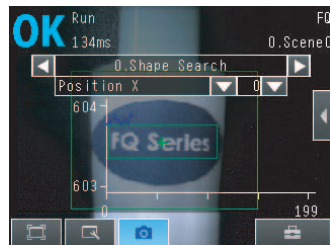

The statistical data for the currently selected inspection item can be checked against time.

p. 184

#### Histogram

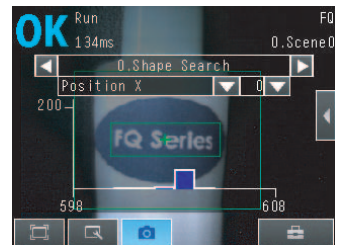

The distribution of measurement results of the currently selected inspection item can be checked.

p. 185

## ▶ (Run Mode) – [Select display]

### Note

If [Logging setting] is not set to [ON], you will not be able to display trend monitors or histograms in Run Mode.

Enabling File Logging: p. 212

The following displays are convenient if more than one Sensor is connected.

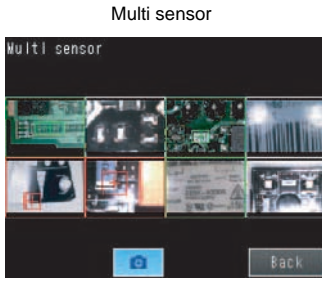

Displays the measurement results of all connected Sensors.  
Green display: OK, Red display: NG

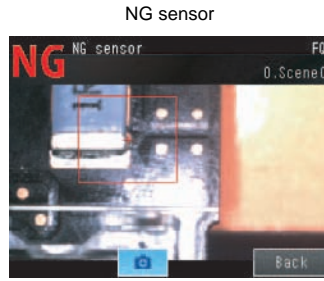

Automatically changes to the display for any Sensor with an NG result.

▶ (Run Mode) – [Sensor monitor]

## Specifying the Startup Run Mode Display

The display that appears when power supply is turned ON can be set.  
The default setting is [Graphics].

▶ (Setup Mode or Run Mode) – [TF settings] – [Startup display] – [Display pattern]

### Note

You can set the scene to be displayed when the power supply is turned ON.

Setting the Startup Scene: p. 192

## Displaying the Inspection Item Results

You can scroll through the measurement results of all the configured inspection items by using the following operations.

Switches to the previous inspection item.



### Note

The following are also displayed in addition to the measurement results for each inspection item.

- Filter item: The results of a filter item is displayed.
- Camera input: The image that is being measured is displayed.
- Position comp.: The result of position compensation is displayed.
- All Region: The measurement regions for all inspection items are displayed.
- Calculation: Displays the results for each expression registered to an inspection item.

## 6-3 Checking the Trend of Measurement Results with Graphs

Measurement result histories can be checked using the trend monitor and histograms.

To display trend monitors or histograms in Run Mode, you must make the following setting in advance in Setup Mode.

▶  (Setup Mode) – [TF settings] – [Logging setting] – [ON]

### Trend Monitor

Changes in the measurement values of the selected inspection item against time can be observed from the graph. It becomes possible to predict when malfunctions may occur or to analyze the cause of the malfunction by checking the trends in the measurement values. The most recent 1,000 measurement values are displayed on the graph.

#### • [Trend monitor] Display

Switches the display to the previous inspection item number.

Specifies the parameters to display on the Trend Monitor.

Measurement values

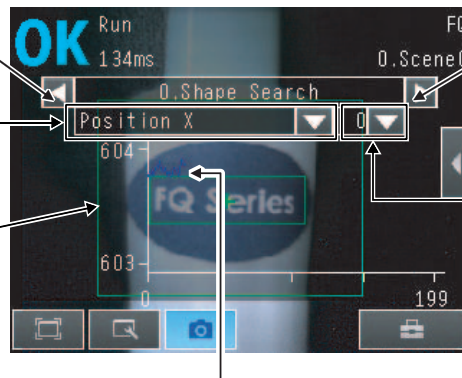

Switches the display to the next inspection item number.

Used to select the detection information to display when more than one detection point is detected at the same time for one item.

Changes in the measured value of the selected inspection item are displayed against time in a graph.

▶  (Run Mode) – [Select display] – [Trend monitor]

### Arranging the Trend Monitor Display

The display range for the vertical axis and display conditions for the horizontal axis can be changed.

#### Note

You can display only one parameter in the Trend Monitor. You cannot display multiple parameters at the same time.

#### • Disabling Automatic Selection of the Display Range

- 1 Press [] – [Auto display] on the right of the trend monitor.
- 2 Press [OFF].

#### • Changing the Display Range of the Vertical Axis

- 1 Press [] – [Display range] on the right of the trend monitor.
- 2 Set the minimum and maximum values of the measurement values.

• **Changing the Number of Values That Are Displayed**

- 1 Press [◀] – [Number of data] on the right of the trend monitor.
- 2 Select the number of values from 200, 400, and 1,000.

**Note**

- Trend monitor data is held until the power supply is turned OFF.
- You can select whether to display all data on the trend monitor or only data for which the overall judgement is NG. Logging settings are applied to the trend monitor as well. However, they are not applied to trend monitor when it is displayed in Setup Mode.

 Check recent measurement trends (recent results logging): p. 214

## Histograms

The distribution of each measurement value can be checked on a histogram. The most recent 1,000 measurement values are displayed on a graph.

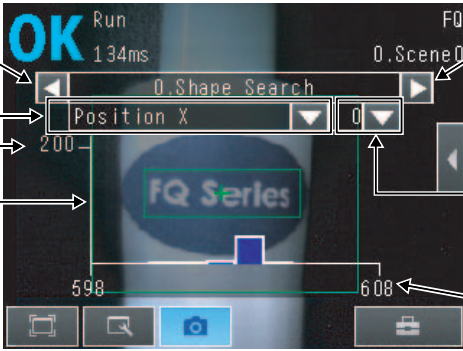

Switches the display to the previous inspection item number.

Switches the display to the next inspection item number.

Specifies the parameter to display on the histogram.

Number of measurement values

Used to select the detection information to display when more than one detection point is detected at the same time for one item.

Measurement values

The distribution of the measurement values that are equivalent to the judgement values is displayed in a histogram for the selected inspection item.

▶  (Run Mode) – [Select display] – [Histogram]

### Arranging Histogram Display

The display range on the horizontal axis and the number of data on the vertical axis of the histogram can be changed.

• **Disabling Automatic Adjustment of the Display Range**

- 1 Press [◀] – [Auto display] on the right of the histogram.
- 2 Press [OFF].

• **Changing the Display Range of the Horizontal Axis**

- 1 Press [◀] – [Display range] on the right of the histogram.
- 2 Select the maximum measurement value, the minimum measurement value, and the class.

• **Changing the Number of Data on the Vertical Axis**

- 1** Press [] – [Number of data] on the right of the histogram.
- 2** Select the maximum number of data to display.

**Note**

- 
- Histogram data is held until the power supply is turned OFF.
  - You can select whether to display all data in the histogram or only data for which the overall judgement is NG. Logging settings are applied to the histogram as well. However, they are not applied to histograms displayed in Setup Mode.



Check recent measurement trends (recent results logging): p. 214

---



# 6-4 Adjusting Judgement Parameters during Operation

This Sensor enables judgement parameters to be adjusted while measurements are being performed. Downtime can be eliminated with this feature because the production line does not have to be stopped while making adjustments.

## Preparations

This function is switched OFF as a default to prevent it from inadvertently working during operation. Turn ON the function if you want to use it.

▶  (Setup Mode) – [Sensor settings] – [Adjustment mode in Run]

- 1 Press [ON].

## Changing the Judgement Parameters in Run Mode

This section describes how to change the judgement parameters without stopping measurement in Run Mode.

▶ Run Mode

- 1 Select the inspection item for which you want to adjust the judgement parameters using the ◀ and ▶ Buttons.
- 2 Press [◀] – [Adjust judgement].
- 3 Press the parameters and change the values of the judgment conditions for them with the slider.
- 4 Press [OK].  
The judgement results with the changed judgement parameters will appear.



**Important**

The changed judgement parameters will not be reflected in the measurement result until [OK] is pressed.

MEMO

# Convenient Functions

---

7-1 Changing the Scene to Change the Line Process .....	190
7-2 Calibration .....	193
7-3 Display Functions .....	200
7-4 Monitoring the Signal I/O Status.....	203
7-5 Connecting to More Than One Sensor.....	204
7-6 Logging Measurement Data and Image Data .....	208
7-7 Saving Sensor Settings.....	218
7-8 SD Card Operations .....	220
7-9 Convenient Functions for Operation.....	223
7-10 Convenient Functions for Setup.....	227
7-11 Functions Related to the System .....	229

# 7-1 Changing the Scene to Change the Line Process

## What Are Scenes?

With an FQ2 Vision Sensor, the inspection items that can be processed at the same time are registered as scenes. A command input from an external device or a touch panel operation can be used to select a certain scene.

If a scene is registered for each type of measurement object or inspection, the line process can be changed simply by changing the scene when the measurement object or inspection changes.

Example:

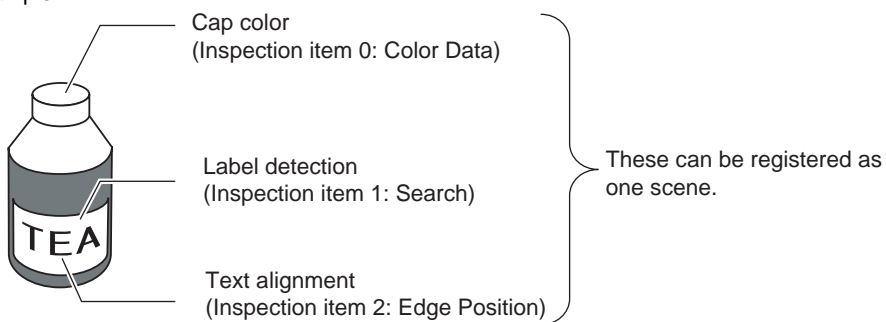

Line Process Changes:

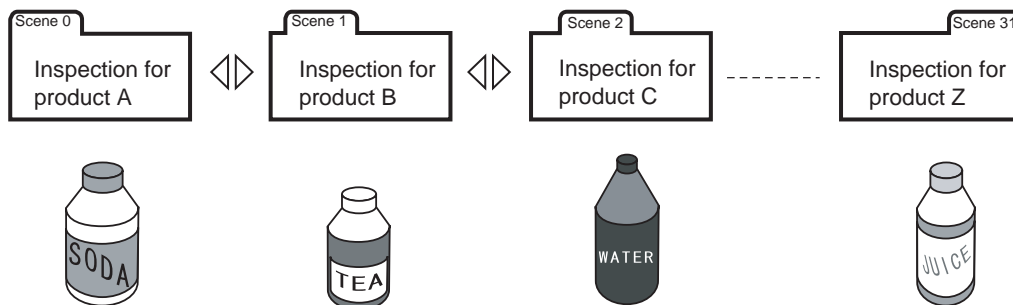

### • Maximum Number of Scenes

Item	Model	Standard model (FQ2-S2/S3 Series)	Single-function model (FQ2-S1 Series)
Number of scenes		32	8

### • Settings Included with Scenes

The following settings are changed when the scene is changed: Camera image ([Image] Tab Page) and Inspection Items ([Inspect] Tab Page). The settings related to external I/O specifications that are included in the output settings and the system settings for the overall Sensor are used for all of the scenes.

Refer to the following information for the data that is included in the scene data.

12-1 Menu Tables: p. 404

## Creating New Scenes

The default scene number is 0. To create another scene, use the following procedure to switch the scene and then make the settings.

### ▶ (Setup Mode) – [Select scene]

- 1 Press the number of the scene to change to and then press [Select].
- 2 The scene will change. Make the settings for the scene.

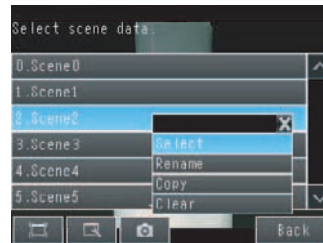



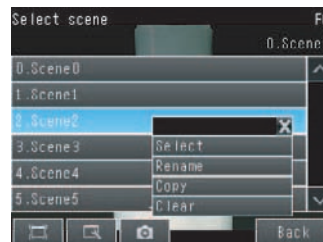

## Changing Scene Names, Copying Scenes, and Deleting Scenes

### ▶ (Setup Mode) – [Select scene]

- 1 Press the number of the scene and then press [Rename], [Copy], or [Clear].
- 2 To change the name, enter a new scene name in 15 alphanumeric characters or less.  
To copy a scene, press the number of the scene to copy.



## Switching Scenes from an External Device

- Changing Scenes with a Parallel Input Command  
 p. 246, p. 272
- Changing Scenes with a PLC Link Command  
 p. 342
- Changing Scenes with an EtherNet/IP Command  
 p. 314
- Changing Scenes with a TCP No-protocol Command  
 p. 367
- Changing Scenes with a FINS/TCP No-protocol Command  
 p. 384

## Setting the Startup Scene

▶  (Setup Mode) – [Sensor settings] – [Startup settings]

The following items can be set.

Item	Purpose	Setting range
Startup mode	Select whether the startup scene number is set manually.	ON OFF (The scene number when the settings were saved will be the startup scene number. The startup mode is set to OFF in the default settings.)
Startup scene	Set the scene number to use at startup.	Standard models: 0 to 31, Single-function models: 0 to 8, Default: 0

# 7-2 Calibration

## Calibration

Calibration is used to convert Camera coordinates into actual coordinates.  
You can set calibration to output the detected position in the actual coordinates.

You can convert pixels to actual dimensions and then output them.

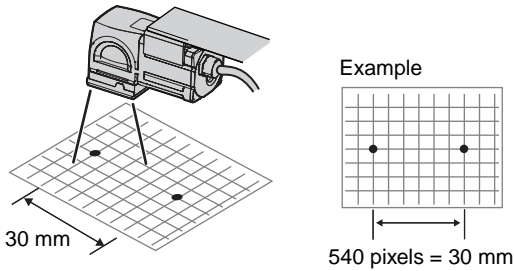

You can also compensate for offsets in the origin and coordinate system.

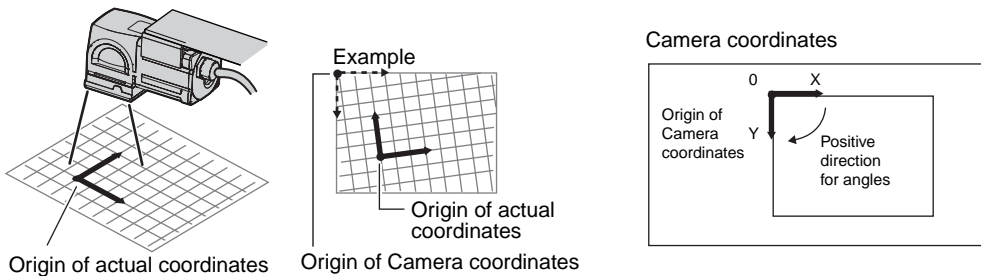

### • Calibration Conversion Methods

There are the following three conversion methods for calibration.

Point specification: You can enter the actual pixel coordinates of any position.

Reference: You can measure a registered model and then enter the actual coordinates of the model.

Parameter: You can enter the calibration values directly.

### • Setting Calibration

Use the following procedure to set calibration.

#### 1 Set the conversion method to use for calibration.

Select the calibration method (point specification, reference, or parameter) and enter the actual coordinates or other values that are suitable for the selected method.

You can register up to 32 calibration patterns.

Calibration type	Description	Reference
Specify point (point specification)	Specify from two to ten points and enter their actual coordinates.	p. 194
Reference sampling (reference)	Search for a registered model and enter the actual coordinates of the position where the model is detected.	p. 196
Parameter	Enter the numeric values of the parameters directly to calculate the calibration data.	p. 198

## 2 Select the calibration pattern to use.

Select the calibration pattern to use from the calibration settings.

 Selecting the Calibration Pattern to Use: p. 199

### Note

You can set the calibration setting for each scene.

You can use the same calibration setting for different scenes or use a different calibration setting for each scene.

## Setting the Calibration Pattern

### Point Specification

Set the pixel coordinates of positions to set the calibration pattern.

When you enter the actual coordinates of the specified positions, the calibration parameters are automatically calculated.

You can register the coordinates of up to 10 positions.

#### • Different Magnifications in X and Y Directions

Specify three positions.

X : Y = 5 : 3

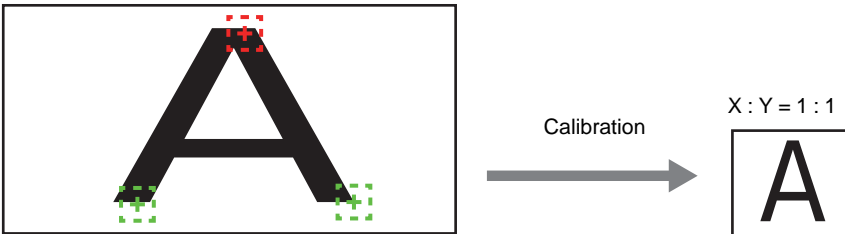

### Note

If two positions are set, a lefthand coordinate system will be set (i.e., clockwise is the positive direction).

If you want to include the coordinate system in the calibration, specify three positions.

### ▶ (Setup Mode) – [Calibration]

- 1 Select the data region to set from [Calibration data 0] to [Calibration data 31].
- 2 Press [Modify].
- 3 Press [◀] – [Specify point] on the right of the display.

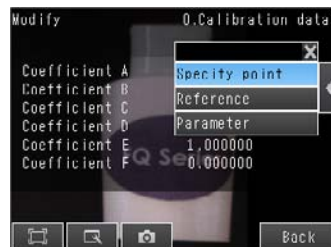



#### 4 Press [No. 1] and then press [Modify].

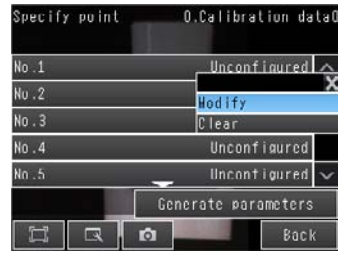

#### 5 Press the Camera coordinates to register on the display to select them.

A cross mark will be displayed on the selected position.

##### Note

- You can enlarge the display.



Image Zoom: p. 200

- You can fine-tune the coordinates that are set.

Press [◀] – [Console] on the right of the display to display the console.

Press the Cross Key on the console to change the coordinates one pixel at a time.

Cross mark



#### 6 Press [OK].

#### 7 Enter the actual coordinates of the specified position.

Press [◀] – [Actual coord.] on the right of the display.



#### 8 Enter the actual X and Y coordinates and press [OK].

#### 9 Repeat the above steps 4 to 8 to set the coordinates of the remaining positions.

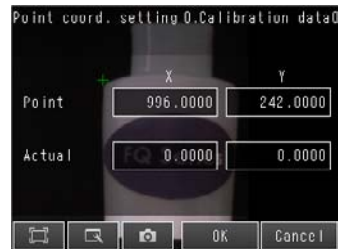

#### 10 When you have finished setting the coordinates for all of the positions, press [Generate parameters].

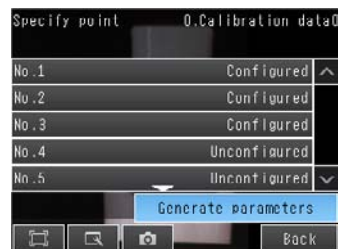

## 11 The calibration parameters will be displayed.

The items in the calibration parameters are listed in the following table.

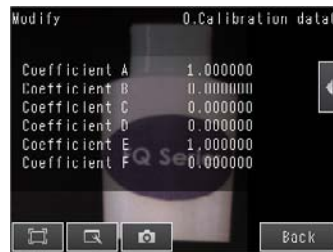

Item	Setting	Description
A	Calculated value	<p>These are the calibration conversion values.                      These values are used to convert the Camera coordinates to the actual coordinates.                      The following formulas are used to convert to actual coordinates.</p> <ul style="list-style-type: none"> <li>• (X,Y): Camera coordinates of measurement position, Unit: pixels</li> <li>• (X',Y'): Converted coordinates (actual coordinates)</li> </ul> $X' = A \times X + B \times Y + C$ $Y' = D \times X + E \times Y + F$
B	Calculated value	
C	Calculated value	
D	Calculated value	
E	Calculated value	
F	Calculated value	

## Reference

With this method, the calibration settings are based on measurement results.

When you enter the actual coordinates of the position that results from searching for a registered model, the calibration parameters are calculated automatically. (The position resulting from the search is found at the subpixel level.)

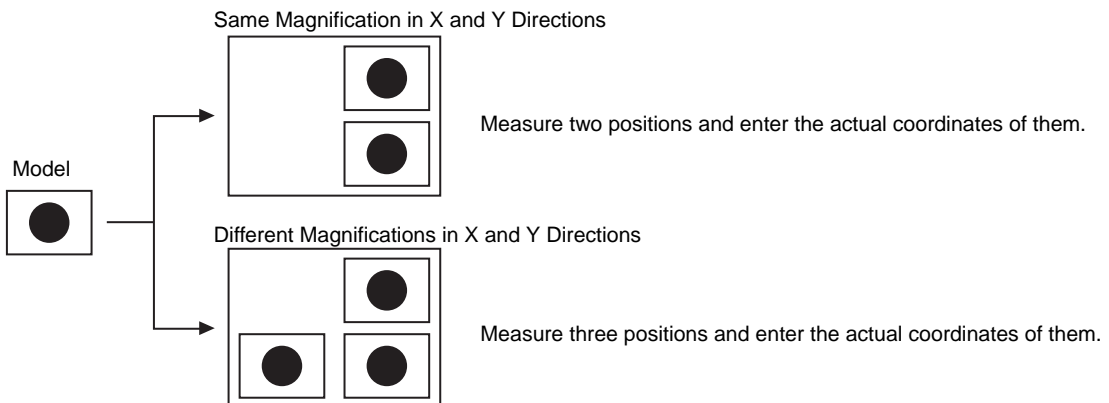

►  (Setup Mode) – [Calibration]

- 1 Select the data region to set from [Calibration data 0] to [Calibration data 31].
- 2 Press [Modify].
- 3 Press [◀] – [Reference] on the right of the display.

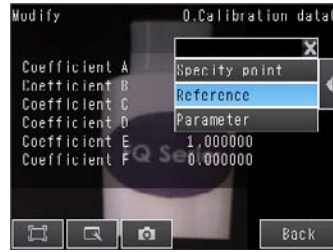

- 4 Press [No. 1] and then press [Modify].



- 5 Move the rectangular frame to specify the model region.

**Note**

- You can edit the model region.  
The procedure is the same as that for the search function.

 Editing the Model and Measurement Regions: p. 100



- 6 Press [OK].
- 7 Press a reference sample to get the Camera coordinates.
- 8 Enter the actual coordinates of the specified position.  
Press [◀] – [Actual coord.] on the right of the display.

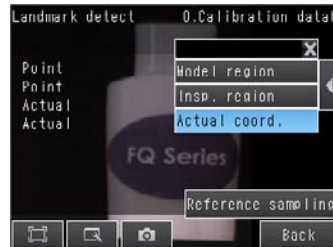

- 9 Enter the actual X and Y coordinates and press [OK].
- 10 Repeat the above steps 4 to 8 to set the coordinates of the remaining positions.

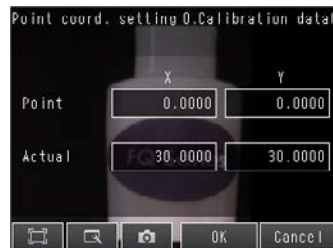

- 11** When you have finished setting the coordinates for all of the positions, press [Generate parameters].



- 12** The calibration parameters will be displayed. The items in the calibration parameters are the same as those for point specification.

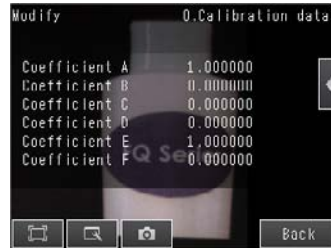

## Parameter

With this method, you directly enter values to set calibration.

The calibration parameters will be automatically calculated when you enter the following three parameters.

Parameter	Setting	Description
Coordinate (coordinate system)	Righthand or Lefthand Default: Lefthand	<p>Lefthand: The positive direction is clockwise when coordinates are specified. Righthand: The positive direction is counterclockwise when coordinates are specified.</p>
Origin	Upperleft, Lowerleft, or Center Default: Lowerleft	<p>Select the location of the origin of the coordinate system.</p>
Magnification	0.0001 to 9.9999 Default: 1.0000	Set the actual dimension that corresponds to one pixel.

►  (Setup Mode) – [Calibration]

- 1 Select the data region to set from [Calibration data 0] to [Calibration data 31].
- 2 Press [Modify].
- 3 Press [◀] – [Parameter] on the right of the display.

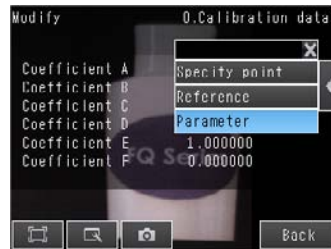

- 4 Set the following parameters: [Coordinate], [Origin], and [Magnification].
- 5 Press [OK].



- 6 The calibration parameters will be displayed.  
The items in the calibration parameters are the same as those for point specification.

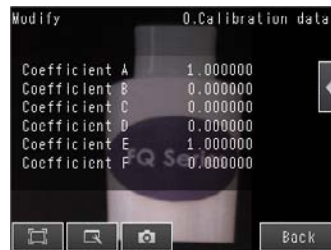

## Selecting the Calibration Pattern to Use

In the Camera setup, select the calibration pattern to use.

**Note**

You can select the calibration pattern for each scene.

► [Image] – [Camera setup]

- 1 Press [◀] – [Select calib. data] on the right of the display.
- 2 Select the calibration pattern from [Calibration data 0] to [Calibration data 31].
- 3 Press [Back].

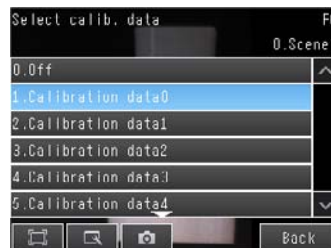

**Note**

If the selected calibration data has not been set yet, a message will be displayed asking if you want to go to the calibration setting display.

# 7-3 Display Functions

The procedures given in this section can be used to make the Sensor easier to use and the display easier to see.

## Image Zoom

The display can be zoomed in or out to make the image easier to see.

### ▶ (Setup Mode or Run Mode)



Enlarges the display.

Reduces the display.

Fits the image to the display size.

Press [Back] to end setting the display.

## Displaying a Live Image

You can display a live image to check the image that is input by the Sensor in realtime.

### ▶ (Setup Mode)

- 1 Press .
- 2 Press [Camera].
- 3 Press [Live].
- 4 Press the [Back] Button to return to the [Display] Display.

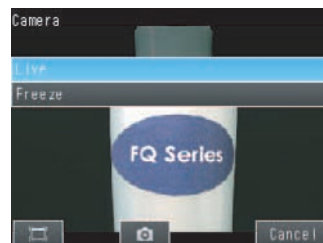

## Displaying a Frozen Image

You can display a frozen image to stop image refreshing and display the last image that was input.

### ▶ (Setup Mode)

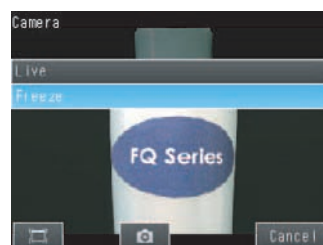

- 1 Press .
- 2 Press [Camera].
- 3 Press [Freeze].
- 4 Press the [Back] Button to return to the [Display] Display.



## Displaying a Saved Image

You can display an image that was saved in internal memory in the Sensor or in an SD card. This can be done to configure inspection items or to check measurements using saved images.

### ▶ (Setup Mode)

- 1 Press .
- 2 You can select one of the following types of images to display.
  - [Log]:  
Images that are logged in the Sensor's internal memory
  - [Logging image file]:  
Images that are logged in the SD card
  - [Camera image file]:  
Images that were logged with  (Logging Button)
- 3 Press the [Back] Button to return to the [Display] Display.



 Saving the Currently Displayed Camera Image:  
p. 224

#### Note

Refer to the following information for the procedures to save images.

 Logging Measurement Data: p. 208

## Updating the Display and Measurement Results Only for NG Measurement Results

In Run Mode, you can specify updating the display of the image and measurement results only when the measurement result is NG.

### ▶ (Run Mode)

- 1 Press .
- 2 Press [Last NG image].
- 3 Press [Back].



Change the following setting to display the last NG image after restarting.

▶  (Setup Mode or Run Mode) – [TF Settings] – [Startup display] – [Display update mode]

1 Press [Last NG image].



#### Note

If an operation to change the display is performed (e.g., if the display pattern is changed or the inspection item is changed) when displaying images for NG results is set, the display will change to refreshing the most recent measurement results and the most recent NG display will disappear.

To ensure that you can check the NG results, log the NG results.



Checking Recent Measurement Trends (Recent Results Logging): p. 214

## Automatically Changing to the Display for Any Sensor with an NG Result

You can change the settings to automatically display the Sensor for which the measurement result is NG if more than one Sensor is connected.

▶  (Run Mode) – [Sensor monitor] – [NG Sensor]

## Hiding the Menu

You can hide the menu and display only the image on the Touch Finder or PC Tool to check the part of the image hidden behind the menu.

If you press the icon again, the menu will be displayed.

▶  (Setup Mode or Run Mode)

## Turning ON/OFF the Touch Finder Backlight

You can use Eco Mode to turn OFF the LCD backlight and reduce the power consumed by the Touch Finder whenever there is no operation on the Touch Finder for 30 seconds or longer. The LCD backlight will turn ON whenever any part of the touch panel is pressed.

▶  (Setup Mode or Run Mode) – [TF settings] – [LCD Backlight] – [ECO mode]

## Changing the Brightness of the Touch Finder

The brightness of the LCD backlight can be changed to any of five levels.

▶  (Setup Mode or Run Mode) – [TF settings] – [LCD Backlight] – [Brightness]



# 7-4 Monitoring the Signal I/O Status

You can check if the I/O connections are working normally.

► [In/Out] – [I/O monitor] – [I/O monitor]

- 1 The I/O status of the external devices will be displayed.
- 2 Press the [OK] Button to return to the [Communication check] Display.

Input Signals (TRIG and IN0 to IN5)  
Signals that are displayed in red are currently being input from the external devices to the Sensor.



Output Signals  
(OUT0, OUT1, and OUT2)  
Signals that are displayed in red are currently being output from the Sensor to the external devices.  
You can turn the signals ON and OFF by pressing them to test the outputs.

**Note**

When the Sensor Data Unit is connected, the I/O status of the following signals are displayed.

- FQ-SDU1□: TRIG, DSA, RST, IN0 to IN7,  
RUN, OR, BUSY, ERR, STG, SHT, ACK, GATE, and D0 to D15
- FQ-SDU2□: TRIG, RST, IN0 to IN5,  
RUN, OR, BUSY, ERR, STG, SHT, and ACK

# 7-5 Connecting to More Than One Sensor

You can connect up to eight Sensors to one Touch Finder or computer.

This sections describes how to connect more than one Sensor to a Touch Finder or computer.

## Setting the Sensors to Connect

Use the following setting to connect more than one Sensor to a Touch Finder.

### Automatically Connecting Sensors

The Touch Finder can detect Sensors and automatically connect to them in the order that it detects them. The Touch Finder can detect up to 32 Sensors and it can connect to up to eight Sensors at the same time. Set this parameter to [OFF] to connect to only a specific Sensor.

#### ► (Setup Mode or Run Mode) – [TF settings]

- 1 Set [Auto sensor detection] to [ON].

#### Note

If there are more than eight Sensors available for connection, use [Specify sensor] to select the Sensors to connect.

 3-1 Selecting a Sensor for Configuration: p. 58

### Registering the Sensors to Connect

You can set any of the Sensors for connection to the Touch Finder and register them.

#### ► (Run Mode) – [Sensor monitor] – [Multi sensor]

- 1 Press [] – [Specify sensor] on the right of the display.

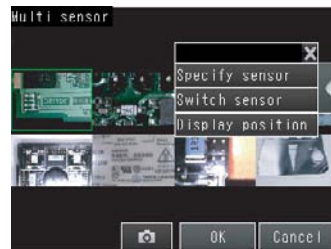

- 2 Press a blank line and then press [Add].

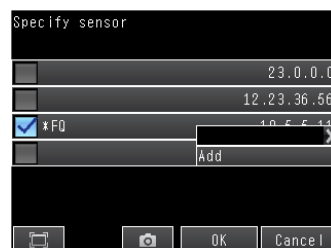

- 3 Enter the IP address.
- 4 Press the IP address that you entered, and then press [Comm. test] to confirm that connection is possible.

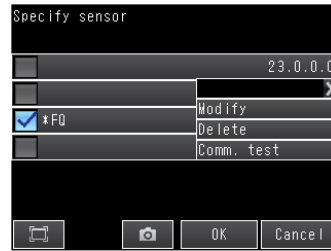

## Selecting the Sensors to Connect

You can select the Sensors to connect to the Touch Finder from a list.

### ► (Run Mode) – [Sensor monitor] – [Multi sensor]

- 1 Press [◀] – [Specify sensor] on the right of the display.
- 2 Press the check boxes of the Sensors to connect to select them.

#### Note

- The Sensors that can be set are indicated by an asterisk before the Sensor name.
- You cannot select the check box if a Sensor that was registered by the user cannot be detected.
- The names of Sensors that are on the same network as the Touch Finder are given in parentheses.

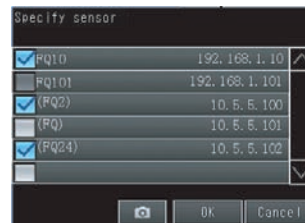





## Selecting the Display When More Than One Sensor Is Connected

### Selecting the Display When More Than One Sensor Is Connected

You can select the display to appear on the Touch Finder when more than one Sensor is connected.

►  (Setup Mode or Run Mode) – [TF Settings] – [Startup display] – [Startup screen type]

**1** Select one of the following display types.

Display type	Description
Multi Sensor	<p>Simultaneously displays the images from up to eight detected Sensors. The display positions for Sensors that are not connected will remain blank.</p> <ul style="list-style-type: none"> <li>The Sensors are connected in the order that they are detected. You can change the display positions of the Sensors.                               Specifying Sensor Display Positions for Multiple Sensors ([Multi Sensor] or [Auto] Only): p. 206                         </li> <li>If there are more than eight Sensors that can be connected, select the Sensors to connect from the list of Sensors                               Selecting the Sensors to Connect: p. 205                         </li> <li>Register the Sensor to connect to display a specific Sensor.                               Registering the Sensors to Connect: p. 204                         </li> </ul>
NG sensor	Of the connected Sensors, displays the image from the Sensor that most recently had an NG result.
Single sensor	<p>Displays the image from only one Sensor. Of the Sensors, the image from only the Sensor that is specified in [Sensor selection] is displayed. If a Sensor is not specified in [Sensor selection], the image from the first Sensor that is detected will be displayed.</p>  Specifying the Sensors to Connect Continuously: p. 225
Auto (default)	Automatically adjusts the display according to the number of Sensors that are detected. If more than one Sensor is detected, the images from up to eight Sensors are displayed at the same time. If eight Sensors are connected, the display is the same as that for [Multi sensor].

### Specifying Sensor Display Positions for Multiple Sensors ([Multi Sensor] or [Auto] Only)

If [Startup screen type] is set to [Multi sensor] or [Auto],\*1 you can specify the position of the image on a split display for each Sensor that is displayed.

\*1 This can be done only when the maximum number of Sensors (eight) are connected.

►  (Run Mode) – [Sensor monitor] – [Multi sensor]

- Press [◀] – [Display position] on the right of the display.
- Press the display of the Sensor for which to specify the display position. A list of numbers for the display positions will be displayed.
- Select a number from the list of display positions. The display for the Sensor will be displayed in the position that corresponds to the specified number.



**Note**

---

The display positions that are set with [Display position] are cleared when the power supply to the Touch Finder is turned OFF.

However, if the Sensor status is changed (by changing from Setup Mode to Run Mode), the current settings for [Display position] are saved in the Touch Finder. Therefore, the next time the same Sensors are connected, they will be displayed in the same positions.

If a previously connected Sensor is not detected, either the display position will be blank, or if [Auto sensor detection] is set to [ON], the Touch Finder will display another Sensor that it has detected.

If a previously connected Sensor is then detected by the Touch Finder, it will display the image from it in the previous display position.

---

# 7-6 Logging Measurement Data and Image Data

There are two ways to log data.

Recent results logging: Data is temporarily saved in memory inside the Sensor.

File logging: Large amounts of data are saved in SD cards or other external media.

The amounts and types of data that can be logged depend on the logging method that is used, as shown in the following table.

Logged data	Logged quantity	
	Recent results logging <sup>*1</sup>	File logging
Statistical data	One value (The average value of the measurement results in the collected measurement data is continuously updated.)	Not possible.
Measurement data	1,000 measurement values max. <sup>*2</sup>	Up to the capacity of the external memory
Image data	20 images max.	

\*1 For recent results logging, the oldest data is overwritten when the maximum number of saved data items is exceeded.

\*2 This limit is for one data item.

If more than one data item is logged at the same time, logging can be performed as long as the total number of data items in all logged data is 32,000 or less.

## Logging Procedure

Use the following procedure to log data.

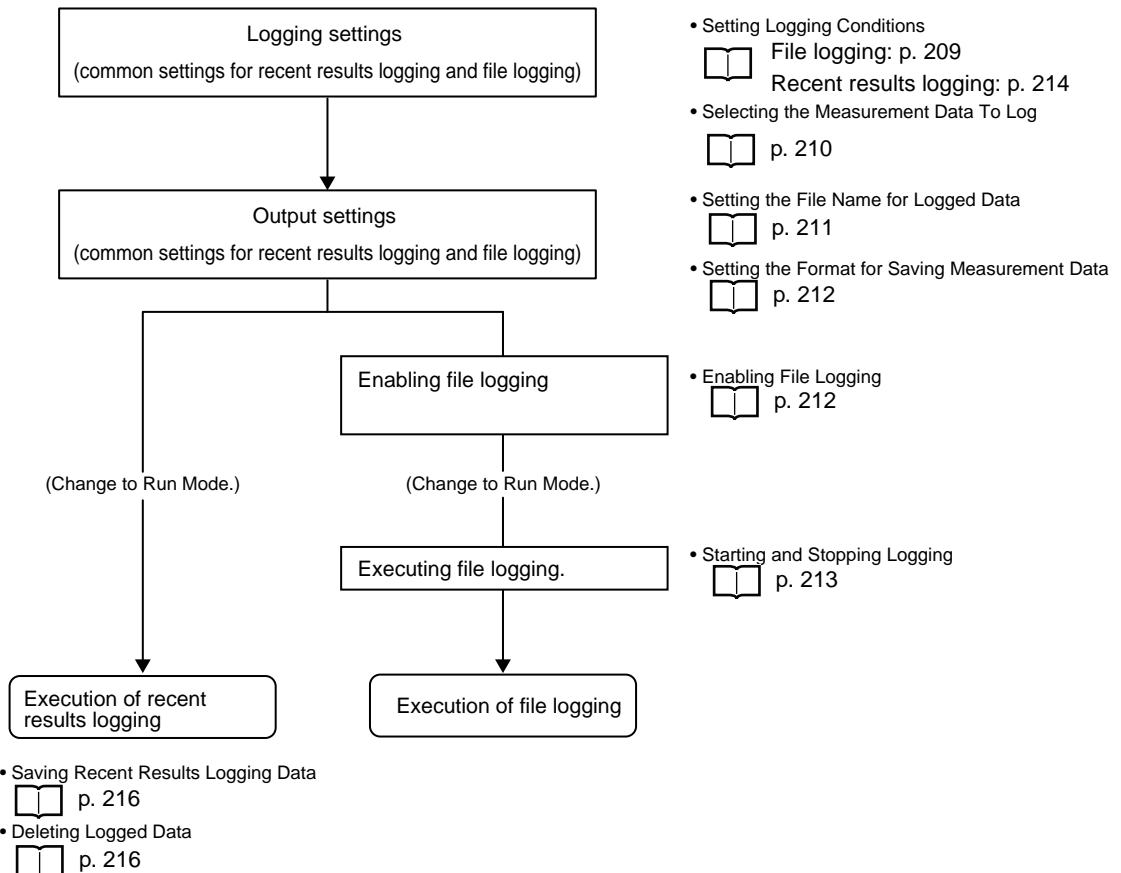

## Logging All Data (File Logging)

Large amounts of measurement and image data can be saved in files in external memory (SD cards or computer).

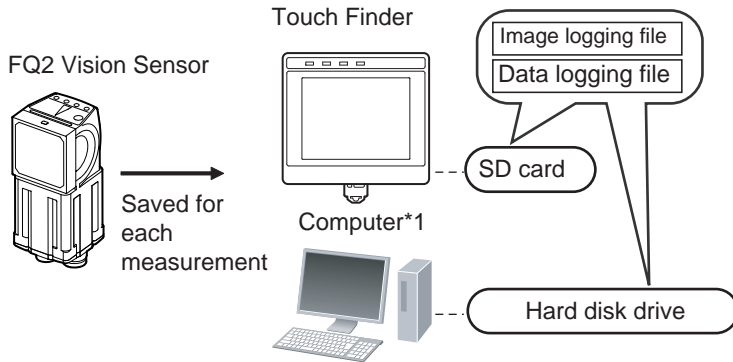

\*1: Image data and measurement data can be logged in the same way as for the Touch Finder by installing the PC Tool for FQ.

System Configuration: p. 26

### Note

Only the data for the Sensor that is currently being displayed will be logged even if more than one Sensor is connected.

If multiple sensors are displayed, or if the most recent NG sensor is displayed, only the results of the sensor that was displayed before changing to the other sensor monitor screen will continue to be logged. Simultaneous logging of the results of multiple sensors is not possible.

## Setting Logging Conditions

Use the following procedures to set the conditions to log data.

### ► [In/Out] – [Log setting]

- Image Data

- 1 Press [Image logging].
- 2 Change the logging conditions, and then press [Back].



• Measurement Data

- 1 Press [Data logging] – [Condition].
- 2 Change the logging conditions, and then press [Back].



Item	Description
Image logging (image data)	<ul style="list-style-type: none"> <li>• All: All images will be logged regardless of the measurement results.</li> <li>• Only NG: Only images for which the overall judgement was NG will be logged.</li> <li>• None: No images will be logged (default).</li> </ul>
Data logging (measurement data)	<ul style="list-style-type: none"> <li>• All: All measurement data (Measured values and calculation results) will be logged regardless of the measurement results.</li> <li>• Only NG: Only measurement data (Measured values and calculation results) for which the overall judgement was NG will be logged.</li> <li>• None: No measurement data (Measured values and calculation results) will be logged (default).</li> </ul>

**Note**

The logging parameter settings are the same for recent results logging.

## Selecting the Measurement Data To Log

Use the following procedure to select the measurement data to log.

- [In/Out] – [Log setting] – [Measurement data] – [Select data]

- 1 Press the inspection item or expression that has the parameter for which to log data.

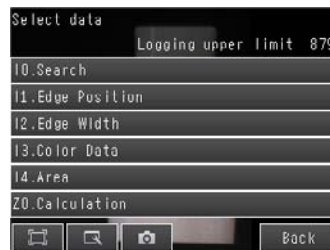

- 2 Press the parameter for which to log data to select it.



**Note**

The procedure to select the measurement data to log is the same for recent results logging.



## Storage Locations and File Names for Logged File Data

Data	Storage location	File name
Image logging (image data)	\\sensor_name\ LOGIMAGE\number* <sup>1</sup> , * <sup>2</sup>	img_YYYY_MM_DD-HH_MM_SS.IFZ <sup>3</sup> Example: The following name would be used for measurements performed at 10:10:21 pm on May 10, 2012: img_2012_05_10-22_10_21.IFZ
Data logging (measurement data)	\\sensor_name\LOGDATA* <sup>2</sup>	File name_YYYY_MM_DD-HH_MM_SS.CSV <sup>4</sup> Example: The following name would be used for measurements performed at 10:10:21 pm on May 10, 2012: 2012_05_10-22_10_21.CSV

\*1: A five-digit number is assigned as a name to the image data storage folder in the order of folder creation as shown below.

Up to 100 images are stored in each folder.

00000  
00001  
⋮

\*2: Files are stored in the following folder when the PC Tool is used.

\\My Documents\OMRON FQ\SDCard

\*3: You can change the “img” at the beginning of the file name.

\*4: You can add a character string to the beginning of the file name.

### • Setting the File Name for Logged Data

You can set a character string to add to the beginning of the file name for logged data.

Image data: You can change the “img\_” at the beginning of the file name for logged data to another text string.

Measurement data: You can add a character string to the beginning of the file name for logged data.

### ▶ (Setup Mode or Run Mode) – [TF settings] – [File format]

- 1** Select the item for which to add to or change the file name and then press [Logging image file] or [Logging data file].
- 2** Press [File name prefix].
- 3** Enter the file name (up to 15 alphanumeric characters) and press [OK].
- 4** Press [OK].

## File Format

Image data: Image data is saved in a special format for OMRON Vision Sensors. (The file name extension is IFZ.)

Measurement data: Measurement data is saved in the following CSV format.

Data	Time	Measurement ID	Scene No.	Judge	I0.CR0	I0.X0	...	I0.CR1	...	I1 Diff	Z0.D00	...
yyyy mm dd	hh mm ss	100	0	0	85	152		79		578	58	
yyyy mm dd	hh mm ss	150	0	-1	88	155		82		581	61	

Diagram annotations: Arrows point to columns 1-5 (Date, Time, Measurement ID, Scene No., Judge). A bracket groups columns 6-11 (Inspection item region). A bracket groups columns 12-13 (Expression region).

Item	Format	Description
1)	Date <sup>*1</sup>	YYYY/MM/DD This is the date that the measurement data was obtained from the Sensor.
2)	Time <sup>*1</sup>	hh:mm:ss This is the time that the measurement data was obtained from the Sensor.
3)	Measurement ID	--- This is the measurement ID information.
4)	Scene No.	--- Scene number
5)	Judge	--- Overall judgement 0: OK, -1: NG, -2: NC (not measured)
6)	Inspection item region	I( <i>inspection_item_number</i> ).(measurement_item)( <i>detection_point</i> ) Example: The correlation of the second detection point in a search for inspection item number 0 would be given as follows: I0.CR2
7)	Expression region	Z0.D** Example: The fourth registered expression would be given as follows: Z0.D04 This is the expression results for each expression.

\*1: The data and time are not recorded with the measurement data. Therefore, this is not the date that the measurement was executed. This is the date that the PC Tool or the Touch Finder obtained the data from the Sensor.

## Changing the Format for Saving Measurement Data

The output CSV file format can be changed according to the external device.

▶  (Setup Mode or Run Mode) – [TF settings] – [File format] – [Logging data file]

- 1 Press [Output format].
- 2 Change the required items in the CSV format.
- 3 Press [Back].

Item	Symbol
Field separator	None, comma (default), tabs, space, colon, semicolon, CR, or CR+LF
Decimal symbol	None, point (default), or comma
Record separator	None, comma, tabs, space, colon, semicolon, CR, or CR+LF (default)

## Enabling File Logging

You must enable file logging before you can execute it.

▶  (Setup Mode) – [TF settings] – [Logging setting]

- 1 Press [ON].

## Starting and Stopping Logging

After logging is started (i.e., set to ON), the specified image data and measurement data will be saved in the SD card or computer hard disk each time measurements are performed.

### ▶ (Run Mode)

- 1 Press [Logging].
- 2 Press [Image logging] or [Data logging].
- 3 Press [ON] to start logging.  
Press [OFF] to stop logging.
- 4 Press [Back].

#### Note

To save logged data, you must first select either [All] (all data is saved) or [Only NG] (only NG data is saved) in the logging parameters.

 Setting Logging Conditions: p. 209

## Ensuring That All Measurement Results Are Logged in External Memory

To ensure that all measurement results are actually saved, change the settings so that the BUSY signal remains ON until logging has been completed. During operation, do not input the next trigger until the BUSY signal turns OFF.

### ▶ [In/Out] – [I/O setting] – [I/O terminals] – [Output] Tab Page – [BUSY output]

Change the BUSY output parameter to [Data logging].

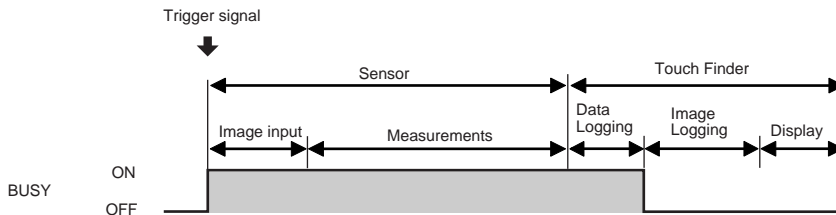

#### Note

- File logging cannot be used when performing continuous measurements.
- If you use the PC Tool, the logging time may vary by up to 100 ms depending on the application conditions of your computer.
- If logging data to an SD card, the write time varies depending on the amount of the available space on the SD card.

Reference value: For SDHC class 4, the time required to write image data is approx. 200 to 800 ms.

## Checking Recent Measurement Trends (Recent Results Logging)

The most recent measurement results can be logged inside the Sensor.

Even if data is not logged in external memory, such as an SD card, trends in measurement results can be easily checked on the Touch Finder.

However, if the power supply is turned OFF or the scene is changed, this data will be lost.

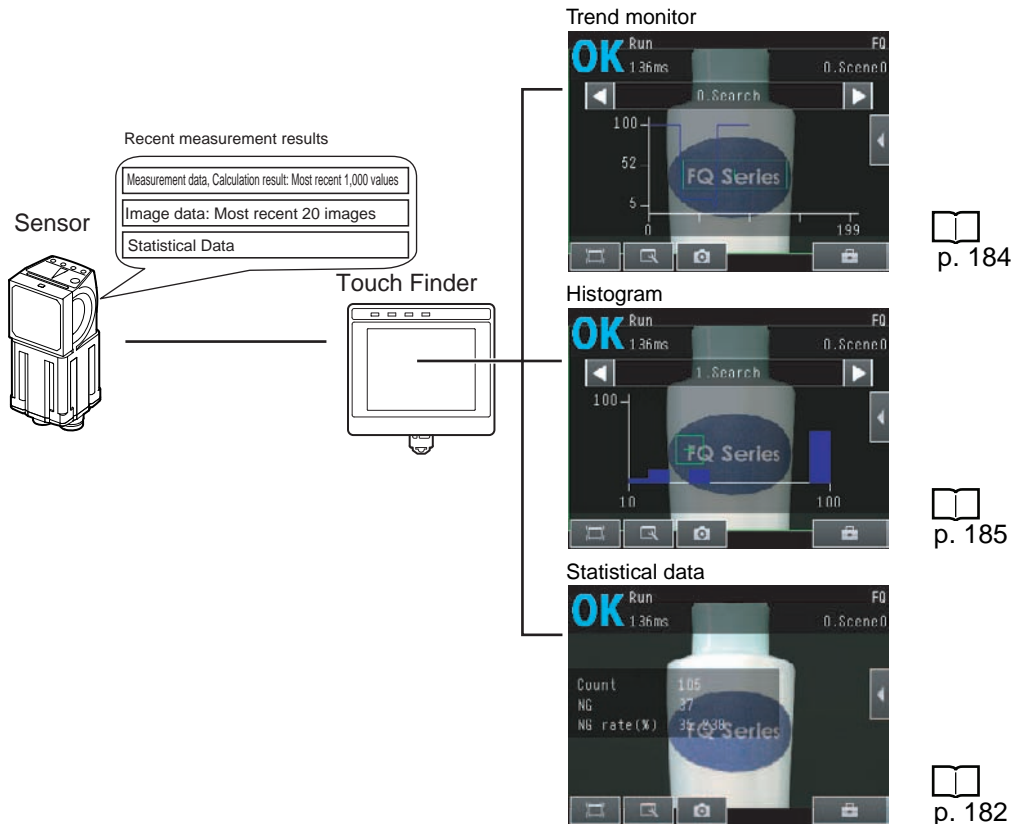

## Setting Logging Conditions

Use the following procedure to set the conditions for the measurement data, image data, and statistical data that will be logged.

Some of these operations and settings are the same as for file logging.

Setting Logging Conditions: p. 209

Item	Description
Statistical data	Statistical data, such as the number of measurements, the number of NG overall judgements, and the NG rate, since the power supply was turned ON will be logged. <ul style="list-style-type: none"> <li>• ON: Statistical data will be displayed (default).</li> <li>• OFF: Statistical data will not be displayed.</li> </ul>
Logging image (image data)	These are the same as for file logging.
Logging data (measurement data)	

### Note

The logging parameters for image data and measurement data are the same as those for file logging.

## Selecting the Measurement Data To Log

---

With recent results logging, you can select what measurement data to log. These settings also apply to file logging.

 Selecting the Measurement Data To Log: p. 210

## Starting Logging

---

Logging will be started as soon as the conditions for logging have been set. If the settings are saved, logging will start automatically the next time the power supply is turned ON.

## Checking the Results of Logging

---

The results of logging can be checked using the trend monitors, histograms, or statistical data.

 p. 182

Use the following menu command to check the image data.

▶  **(Setup Mode)** –  – **[Log]**

## Deleting Logged Data

The logged data will be deleted when the power supply to the Sensor is turned OFF or the scene is changed. The logged data can also be deleted without turning OFF the power supply.

### • Setup Mode

#### ▶ [In/Out] – [Log setting]

1 Press [Delete Log].

## Saving Logged Recent Results Data in a File

Although the logged recent results data will be deleted when the power supply is turned OFF, it can be saved in a file in external memory.

The most recent 1,000 measurement values and the most recent 20 images will be saved.

#### ▶ (Setup Mode) – [Save to file] – [Logging] Tab Page

1 Press the data to save.

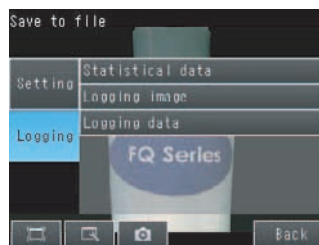

2 The following display will appear if [Logging image] is pressed.

Select whether to save the most recently logged image or to save all of the image data that is logged in the Sensor.



The file storage locations and file format are given in the following table.

Item	Storage location	File name
Statistical data	\\sensor_name\LOGDATA <sup>*1</sup>	File name_YYYY_MM_DD-HH_MM_SS.CSV <sup>*2</sup> Example: The following name would be used for measurements performed at 10:10:21 pm on May 10, 2012: 2012_05_10-22_10_21.CSV
Logging data (measurement data)		
Logging image (image data)	\\sensor_name\LOGIMAGE <sup>*1</sup>	img_YYYY_MM_DD-HH_MM_SS_NNN.IFZ <sup>*3</sup> Example: The following name would be used for measurements performed at 10:10:21 pm on May 10, 2012: img_2012_05_10-22_10_21_000.IFZ “NNN” is a serial number that is added when images are logged at the same time.

\*1: Files are stored in the following folder when the PC Tool is used.

My Documents\OMRON FQ\SDCard

\*2: You can add a character string to the beginning of the file name.

\*3: You can change the “img” at the beginning of the file name.

### • File format

- Statistical data: The data is saved in the following CSV format.  
Number of measurements, number of OKs, number of NGs, OK rate, NG rate (delimiter)
- Image data: Image data is saved in a special format for OMRON Vision Sensors.  
(The file name extension is IFZ.)
- Measurement data: Measurement data is saved in CSV format.

The same format is used to log the most recent results to files for the inspection item region and expression region in the file logging function.

 File Logging Format: Items 8 and 9 on p. 212

#### Note

- 
- The saved recent measurement data cannot be loaded back into the Sensor and displayed on a trend monitor or histogram.
  - The data and time are not recorded with the measurement data.  
The file name is created from the time when the file is saved. It does not indicate when the measurement was made.
- 

#### Important

The recent log data will be cleared if the scene is changed.

## Changing the Format for Saving Measurement Data

---

The output CSV file format can be changed according to the external device.

 Changing the File Format: p. 212

# 7-7 Saving Sensor Settings

The Sensor settings are saved in flash memory inside the Sensor.

This section describes how to back up the settings in and restore them from an SD card or other external memory.

## Backing Up Settings in External Memory

### ► (Setup Mode) – [Save to file] – [Setting] Tab Page

- 1 Press the data to save.
- 2 Enter the file name in 15 characters or less.  
After entering the file name, press [OK]. The data will be saved and the display will return to [Save to file].



### Applicable Data

Data	Storage location <sup>*1</sup>	Description
Scene data (The file name extension is SCN.)	\sensor_name\SCN	The following data is backed up for each scene. <ul style="list-style-type: none"> <li>• Settings for all inspection items</li> <li>• Order of inspection items</li> </ul>
Scene group data (The file name extension is SGP.)	\sensor_name\SGP	All scene data is backed up.
Sensor system data (The file name extension is SYD.)	\sensor_name\SYD	All system data in the Sensor is backed up. The system data is the same for all scenes.
All Sensor data (The file name extension is BKD.)	\sensor_name\BKD	All settings in the Sensor (all scene data, Sensor system data, and calibration group data) are backed up.
Touch Finder data (The file name extension is MSD.)	\MSD	All settings in the Touch Finder are backed up.
Calibration data (file name extension: CLB)	---	The calibration settings for each scene are backed up.
Calibration group data (file name extension: CGP)	---	The calibration settings for all scenes are backed up.

\*1 For the PC Tool, data will be saved in the following folder: \\.\My Documents\OMRON FQ



## Restoring Data to the Sensor from External Memory

▶  (Setup Mode) – [Load from file]

**1** Press the data to be restored.

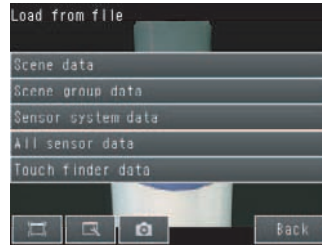

**2** The selected data will be read from external memory and displayed.  
Press the file to load.

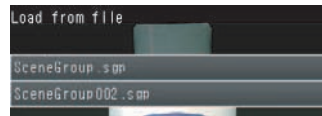

## 7-8 SD Card Operations

With an FQ2 Vision Sensor, the following folders are automatically created in the SD card according to the data that is saved. The specified data is saved in files in these folders.

Storage folder <sup>*1</sup>	Data
\\sensor_name\SCN	Scene data (The file name extension is SCN.)
\\sensor_name\SGP	Scene group data (The file name extension is SGP.)
\\sensor_name\SYD	Sensor system data (The file name extension is SYD.)
\\sensor_name\BKD	All sensor data (The file name extension is BKD.)
\\sensor_name\CLB	Calibration data (The file name extension is CLB.)
\\sensor_name\CGP	Calibration data (The file name extension is CGP.)
MSD	Touch Finder data (The file name extension is MSD.)
\\sensor_name\LOGIMAGE	Image data (The file name extension is IFZ.)
\\sensor_name\LOGDATA	Statistical data and measurement data (The file name extension is CSV.)
\\CAPTURE	Captured images (The file name extension is BMP.) Camera image data (The file name extension is IFZ.)

\*1: For the PC Tool, data will be saved in the following folder: \\..\My Documents\OMRON FQ

**Note**

The PC Tool does not support SD card operations.

## Inserting and Removing SD Cards

### Inserting an SD Card in the Touch Finder

- 1 Open the cover to the SD card slot on the top of the Touch Finder.

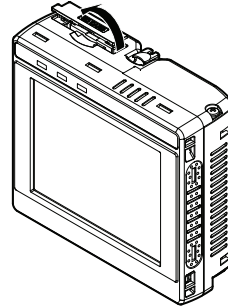

- 2 Insert the SD card with the back of the SD card facing the front of the Touch Finder and press it in until it clicks into place.

- 3 Close the cover to the SD card slot.

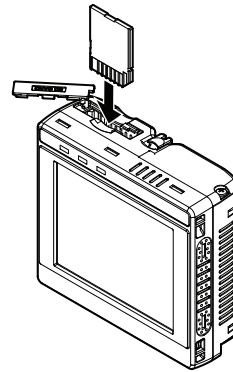

### Removing an SD Card from the Touch Finder

- 1 Open the cover to the SD card slot on the top of the Touch Finder.
- 2 Press in on the SD card until you hear a click.
- 3 Pull out the SD card.
- 4 Close the cover to the SD card slot.

- Never remove the SD card while data is being saved or read. The data on the SD card may be corrupted.

#### Important

Do not restart or turn OFF the power supply to the Sensor or Touch Finder while a message is being displayed saying that data is being saved to or read from the SD card. The settings or system data may be corrupted.

## Checking the Available Space on the SD Card

Before saving data to the SD card, use the following display to make sure that there is sufficient space available on the SD card.

▶  (Setup Mode or Run Mode) – [TF settings] – [SD card] – [SD card information]

The following information in the SD card inserted in the Touch Finder can be checked.



## Formatting an SD Card

▶  (Setup Mode or Run Mode) – [TF settings] – [SD card] – [Format]

Press [Yes] to start formatting.

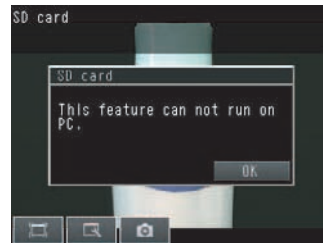

# 7-9 Convenient Functions for Operation

This section describes the functions that can be used during Sensor operation.

## Setting a Password to Prevent Unwanted Changes

A password can be set to prevent unwanted changes to settings.

If a password is set, you cannot change from Run Mode to Setup Mode without entering the password.

### Setting a Password

▶  (Setup Mode) – [Sensor settings] – [Password settings]

- 1 Press [Password on/off] and press [ON].
- 2 Press [Enter password].
- 3 Enter a password containing up to 15 characters and press [OK].

### Clearing the Password

▶  (Setup Mode) – [Sensor settings] – [Password settings]

Press [Password on/off] and press [OFF].

### Entering the password when switching from [Run] Mode to [Setup] Mode.

- 1 If a password is set and you try to change from Run Mode to Setup Mode, the following password entry display will appear.

▶  (Setup Mode) – [Sensor settings]

- 2 Press the text box. A keyboard display will appear. Enter the password and press [OK]. If the password is correct, the Setup Mode will be displayed.

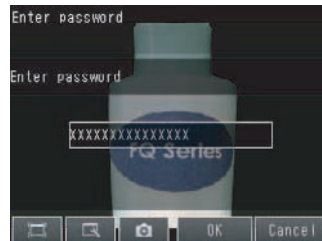

#### Important

- This password restricts only the operation to switch from Run Mode to Setup Mode. It does not restrict other operations.
- If you forget the password, contact your OMRON representative for the procedure to clear the password.
- The password is deleted when the Sensor is initialized.

## Capturing the Displayed Image

The current display on the Touch Finder or PC Tool can be captured and used in text files and other files on the computer.

The captured images are saved in external memory\*<sup>1</sup> as bit maps.

\*1: Images captured on the Touch Finder are saved in the SD card. Images captured with the PC Tool are saved in the computer's hard disk drive.

### ▶ (Setup Mode or Run Mode)

The image that is being displayed when the button is pressed is saved in external memory.

#### • Storage Location and File Names

Storage location	File name
VCAPTURE	YYYY_MM_DD-HH_MM_SS_MS.BMP Example: The following name would be used for an image that was captured at 10:10:21.350 pm on March 10, 2010. 2010_03_10-22_10_21_350.BMP

#### Important

Make sure an SD card is inserted in the Touch Finder before capturing display images.

#### Note

For the PC Tool, data will be saved in the following folder: \\.\My Documents\OMRON FQ

## Saving the Currently Displayed Camera Image

You can save the Camera image that is displayed on the Touch Finder or computer.

### ▶ (Setup Mode) – – (Log Image Button)

The Camera image that is being displayed when the  Button is pressed is saved in external memory.

#### • Storage Location and File Names

Storage location	File name
VCAPTURE	YYYY_MM_DD-HH_MM_SS_MS.IFZ Example: The following name would be used for an image that was captured at 10:10:21.350 pm on March 10, 2010: 2010_03_10-22_10_21_350.IFZ

#### Important

Make sure an SD card is inserted in the Touch Finder before capturing display images.

#### Note

For the PC Tool, data will be saved in the following folder: \\.\My Documents\OMRON FQ

## Setting the Startup Run Display Pattern

You can select the startup run display pattern.

▶  (Setup Mode or Run Mode) – [TF settings] – [Startup display] – [Display pattern]

- 1 Select from the following: [Graphics], [Graphics + Details], [Statistical data], [All results/region], [Trend monitor], or [Histogram].

## Specifying the Sensors to Connect Continuously

You can specify one Sensor to connect to the Touch Finder.

The Touch Finder will connect to that Sensor each time the Touch Finder is started.

▶  (Setup Mode or Run Mode) – [TF settings] – [Startup display]

- 1 Set [Specify sensor] to [ON].
- 2 Set [Sensor selection] to the IP address of the Sensor.

### Note

If the Touch Finder cannot connect to the specified Sensor when the Touch Finder is started, it will continue to retry until a connection is made.

If connection to the specified Sensor is not possible, press the [Cancel] Button to cancel connecting to the specified Sensor.

## Monitoring and Setting Up a Sensor from Two Touch Finders

You can monitor and set up the same Sensor from two Touch Finders.

You can simultaneously monitor the Sensor from both Touch Finders.

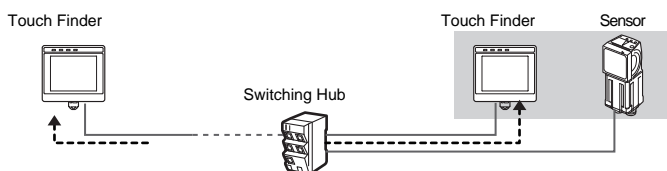

You can set up the Sensor only from one of the two Touch Finders at any one time.



You can monitor the same Sensor at the same time from a locally installed Touch Finder and a remotely installed Touch Finder.

## Operations during Simultaneous Connection of Two Touch Finders

The following restrictions apply to operations when two Touch Finders are simultaneously connected to the same Sensor.

Operation	Sensor status	Changes
Editing model regions in Run Mode	Monitor	Operation is possible with only one of the Touch Finders. Operation will be possible from the Touch Finder where [Model region] was pressed first.
Run Mode operations	Setup	When either of the Touch Finders changes to Setup Mode, operation will no longer be possible from the other Touch Finder. When that occurs, a message will be displayed on the other Touch Finder saying that another Touch Finder is currently setting up the Sensor. A  (Switch sensor) icon will be displayed on the lower right of the display. When Run Mode operations are possible again, Run Mode will be displayed in the initial status.
Logging	Monitoring or setup	Logging (including file logging and recent results logging) can be performed by only one of the Touch Finders. <ul style="list-style-type: none"> <li>If logging is enabled on both of the Touch Finders, logging will be performed only on the Touch Finder that was connected to the Sensor first. An error will be displayed on the other Touch Finder when it connects to the Sensor and logging will automatically be disabled.</li> <li>If logging is disabled on both of the Touch Finders when they are connected, logging will be performed only on the Touch Finder for which logging is enabled first.</li> </ul> You can use the following parameter to enable and disable logging. ►  <b>(Setup Mode) – [TF settings] – [Logging setting]</b>
Trend monitors and histograms	Monitoring or setup	Trend monitors and histograms can be displayed only if logging is enabled. Therefore, they can be displayed only on the Touch Finder for which logging is enabled as described above.



# 7-10 Convenient Functions for Setup

This section describes the functions that can be used when setting inspection items.

## Making Settings with Stored Images

With an FQ2 Vision Sensor, judgement parameters can be set by using the following images.

- Images saved in internal Sensor memory
- Image files in an SD card

### Note

You can also use images that were captured on the display.

 Capturing the Displayed Image: p. 224

## Saving Image Data

### • Temporarily Saving Images in the Sensor

The measured images can be temporarily saved inside the Sensor. These images are held until the Sensor power supply is turned OFF.

▶  [In/Out] – [Log setting] – [Image logging]

 Setting Logging Parameters for Image Data: p. 214

### • Saving Images in the Sensor to an SD Card

The images that are temporarily saved inside the Sensor can be saved to an SD card.

▶  (Setup Mode) – [Save to file] – [Logging] Tab Page

1 Press [Logging image].

2 Select whether to save the most recently logged image or to save all of the data that is logged in the Sensor.

Storage location	File name
\sensor_name\LOGIMAGE	YYYY_MM_DD-HH_MM_SS.IFZ Example: The following name would be used for files saved at 10:10:21 pm on March 10, 2010. 2010_03_10-22_10_21.IFZ

### • Saving Images in an SD Card

The image data can be saved in the SD card each time measurements are performed.

▶  (Run Mode) – [Logging]

 Logging All Data (File Logging): p. 209

You can also save the data in Setup Mode by using  (Display Arrangement) –  (Log Image Button).

## Displaying Image Data

---

- **Images Saved in Internal Sensor Memory**

- ▶  (Setup Mode) –  – [Log]

- **Image Files in a SD Card**

- ▶  (Setup Mode) –  – [Logging image file] or [Camera image file]

 Arranging the Display - Displaying a Saved Image: p. 201

# 7-11 Functions Related to the System

This section describes system settings.

## Turning OFF the Integrated Sensor Lighting (Only Sensors with Built-in Lighting)

The internal light can be turned OFF to use external illumination.

▶  [Image] – [Camera setup] – [] – [Lighting control]  
Press [OFF].

## Switching the Display Language

Any of the following languages can be selected for display on the Touch Panel or PC Tool.

Japanese, English, German, French, Italian, Spanish, Traditional Chinese, Simplified Chinese, or Korean

▶  (Setup Mode or Run Mode) – [TF settings] – [Language]  
Press the language to be displayed.

## Setting the Time on the Touch Finder

You can set the date and time.

▶  (Setup Mode or Run Mode) – [TF settings] – [Time settings]

## Initializing the Sensor and Touch Finder

### • Initializing the Sensor

▶  (Setup Mode) – [Sensor settings] – [Initialize]

### • Initializing the Touch Finder

▶  (Setup Mode or Run Mode) – [TF settings] – [Initialize]

## Restarting the Sensor and Touch Finder

### • Restarting the Sensor

▶  (Setup Mode) – [Sensor settings] – [Restart]

### • Restarting the Touch Finder

▶  (Setup Mode or Run Mode) – [TF settings] – [Restart]

## Checking Versions

### • Checking the Sensor Version

▶  (Setup Mode) – [Sensor settings] – [Information]

### • Checking the Touch Finder Version

▶  (Setup Mode or Run Mode) – [TF settings] – [Information]

## Checking the Touch Finder Battery Level

▶  (Setup Mode or Run Mode) – [TF settings] – [Battery level]

### Important

- The battery level is displayed only for a Touch Finder with a DC/AC/battery power supply (FQ-D31).
- The settings will be lost if the battery runs out while you are making the settings. If the battery level is low, save the settings and charge the battery immediately.

## Changing the Sensor Name

An alphanumeric name can be assigned to a Sensor to make it easier to recognize. This is convenient when more than one Sensor is connected.

▶  (Setup Mode) – [Sensor settings] – [Information] – [◀] – [Rename]

## Checking Available Memory in the Sensor

If a setting cannot be made, check the amount of memory that is available in the Sensor.

▶  (Setup Mode) – [Sensor settings] – [Information] – [◀] – [Memory state]

## Correcting the Touch Screen Positions of the Touch Finder

Use this function to correct the touch screen positions if they are offset from the opposite position.

▶  (Setup Mode) – [TF settings] – [Touch screen calib]

## Setting the Resolution of Measurement Objects Displayed on the PC Tool

Use this function to set the resolution of measurement object that are displayed on the Touch Finder on the computer.

▶  (Run Mode) – [TF settings] – [Resolution]

## Rotating the Touch Finder Image by 180°

You can rotate the Camera image by 180°.

This setting applies to logged images as well.

▶ [Image] – [Camera setup] – [◀] – [Rotate 180]

## Changing the Sensor's BUSY Indicator

You can change the BUSY indicator to a RUN indicator.

▶ **[In/Out] – [I/O setting] – [I/O setting] – [Output] – [BUSY LED]**

MEMO

## Controlling Operation and Outputting Data with a Parallel Connection

---

<b>8-1 Controlling Operation and Outputting Data with the Sensor's Standard Parallel Connection .....</b>	<b>234</b>
<b>8-2 Controlling Operation and Outputting Data with a Parallel Interface Sensor Data Unit .....</b>	<b>256</b>

# 8-1 Controlling Operation and Outputting Data with the Sensor's Standard Parallel Connection

## Basic Operation with a Parallel Connection

This section describes the basic connections and signal flow with external devices. With the default settings, the Sensor operates in the following manner.

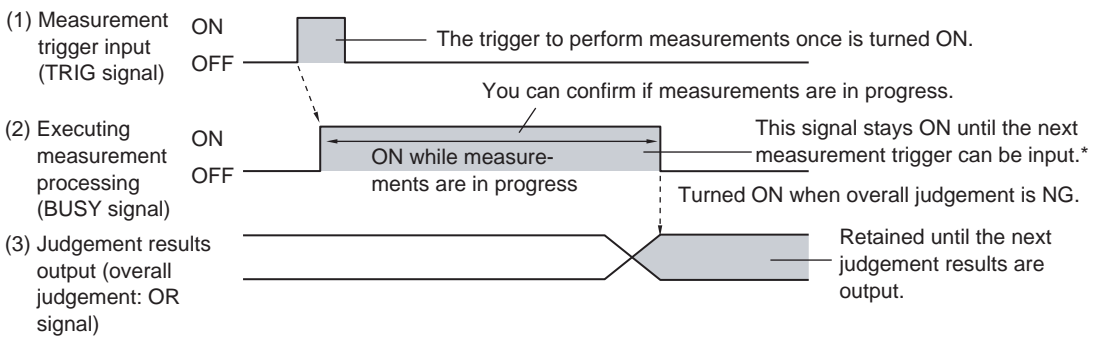
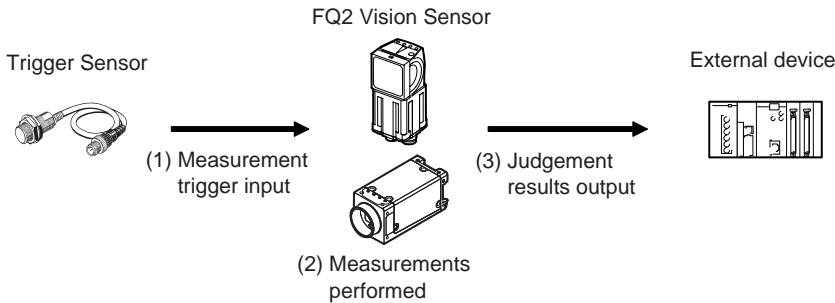

\* You can also use the READY signal, which will turn ON when a measurement trigger can be input. You can assign the READY signal to any output from OUT0 to OUT2.  
(□ Getting Individual Judgements and Expression Judgements: p. 241)

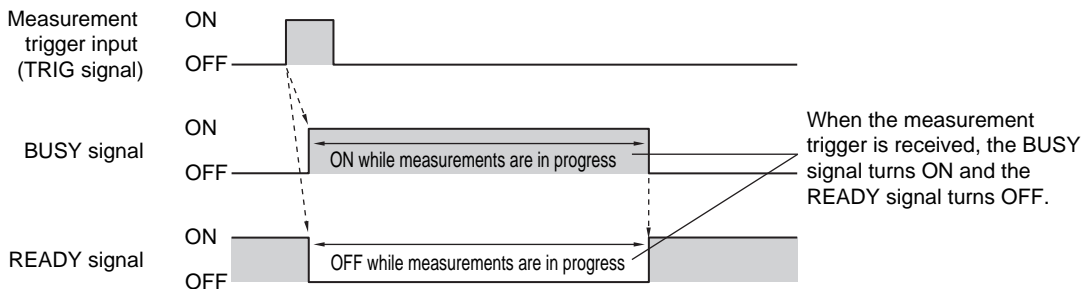



**Important**

- Create the ladder program to control the TRIG and IN5 input signals so that they do not turn ON while the BUSY signal is ON. If not, a TRIG input error will occur and the ERROR signal will turn ON.
- Operation When the Sensor Power Supply Is Turned ON

The BUSY signal will operate as shown below when the Sensor's power supply is turned ON.

Create the ladder program in the PLC or other external device so that the BUSY signal is ignored while it turns OFF, ON, and OFF again for up to 5 s after the power supply is turned ON.

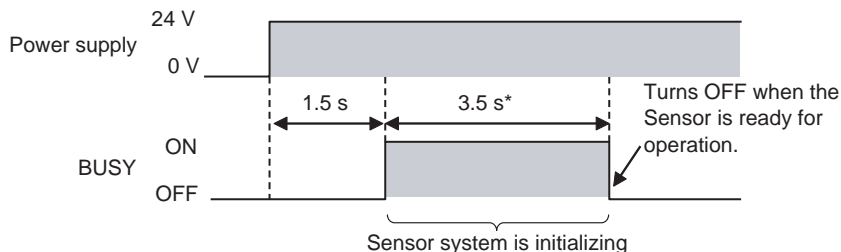

\* Depends on the scene data.

**Note**

You can mount a Parallel Interface Sensor Data Unit to enable using other signals and increase the number of signals that you can use with parallel communications.

And in addition to outputting OR judgement results, you can also use a Parallel Interface Sensor Data Unit to output the judgement results of judgement conditions that you set for parallel output (called parallel judgement output) and the results of measurement values and expressions for inspection items (called parallel data output).

8-2 Controlling Operation and Outputting Data with a Parallel Interface Sensor Data Unit: p. 256

**Configuring the Operation**

The following settings can be selected depending on the system configuration and application.

Type of change	Change	Reference
Changing the type of measurement trigger	Performing continuous measurements	p. 237
Changing the output method of the judgement results	Obtaining individual judgement results	p. 241
	Adjust the judgement output timing	p. 242
	Changing the judgement output ON conditions	p. 244
Changing the polarity of the BUSY output	Reversing the polarity of the BUSY signal	p. 244
Changing the BUSY output condition	Adjusting the end timing of the BUSY signal	p. 244
Changing the polarity of the output signals (OUT1 to OUT3)	Reversing the output polarity of OUT1 to OUT3	p. 244

**Setting the Measurement Trigger**

The measurement trigger can be chosen from the following two types:

- One-shot measurement: One measurement is performed for each external trigger.
- Continuous measurement: Measurements are performed continuously.

## Performing One Measurement for Each External Trigger

A measurement trigger is input as the TRIG signal from a proximity sensor, PLC, or other external device. One measurement is performed when the TRIG signal turns ON.

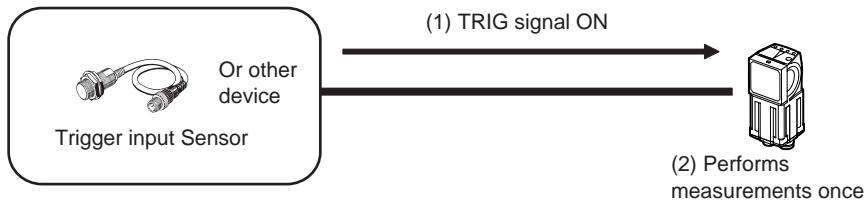

### Wiring

Color	Signal	Description
Pink	TRIG	Trigger signal
Black	OUT0 (OR)	Overall judgement (default assignment)
Orange	OUT1 (BUSY)	Processing in progress (default assignment)

The signals shown at the left are used. Refer to the following information for signal wiring.

Wiring: p. 42

### Timing Chart

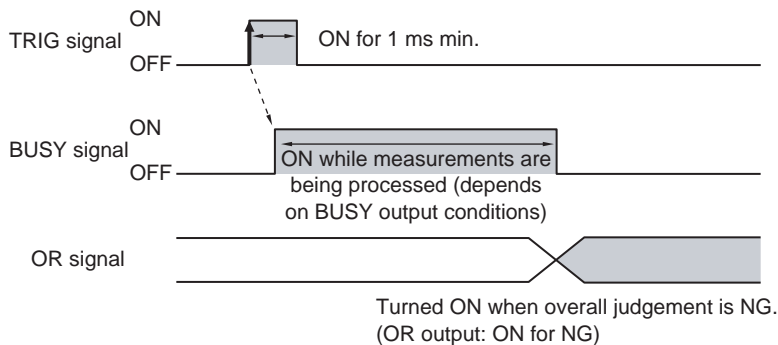

1. Turn ON the TRIG signal while the BUSY signal is OFF.
2. Measurement begins and the BUSY signal is turned ON during the measurement process.
3. When the measurement has been finished, the measurement result is output using an OR signal, and the BUSY signal is turned OFF. \*1

\*1: You can also set the signal to be turned OFF after data logging, image logging, or displaying results in the [BUSY output].

### Important

When the Brightness Correction Mode is ON, the timing when images are taken is delayed.

Timing Chart When the Brightness Correction Mode Is ON: p. 61

## Sample Ladder Program

The following sample program is used to input a TRIG signal to perform a single measurement. A single measurement will be performed when W0.00 turns ON.

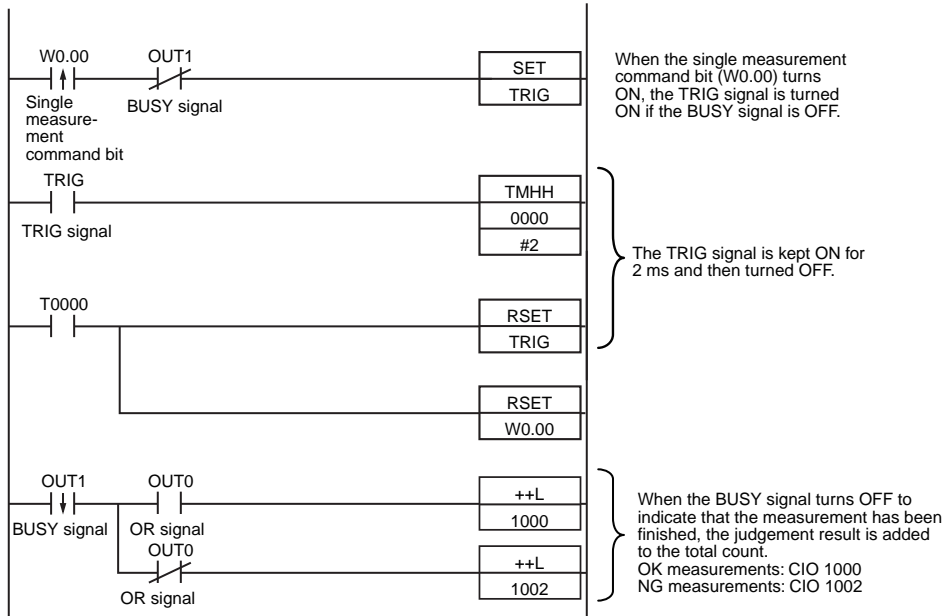

### • I/O Signal Allocations

Signal		Address
Output signals	OUT0 (OR signal)	CIO 0.00
	OUT1 (BUSY signal)	CIO 0.01
Input signals	TRIG	CIO 1.00

### Important

The BUSY signal will remain ON while the measurement is being executed.

## Performing Continuous Measurements

Continuous measurements are performed while the continuous measurement command is input from an external device.

Immediately after a measurement is performed, the next measurement is performed.

This is repeated while a continuous measurement command is input with the IN0 to IN5 signals.

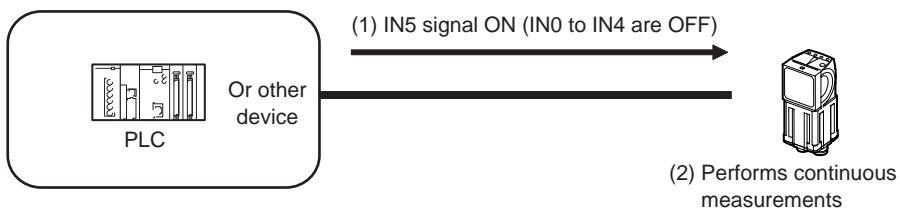

### Note

This function can be used only when the input mode is set to Expanded Mode.

## Wiring

Color	Signal	State	Description
Gray	IN0	OFF	Command parameters for continuous measurements
Green	IN1	OFF	
Red	IN2	OFF	
White	IN3	OFF	
Purple	IN4	OFF	
Yellow	IN5	ON	Command input for continuous measurements
Black	OUT0 (OR)	--	Overall judgement (default assignment)
Orange	OUT1 (BUSY)	--	Processing in progress (default assignment)

The signals shown at the left are used. Refer to the following information for signal wiring.

 Wiring: p. 42

## Timing Chart

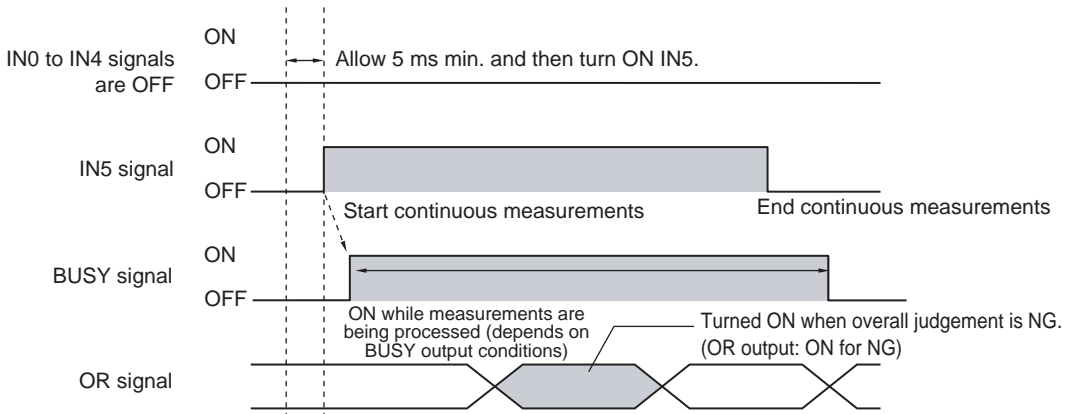

1. Turn ON IN5 while IN0 to IN4 are OFF. If status is held while the BUSY signal is OFF, continuous measurements will begin and the BUSY signal will remain ON while continuous measurements are being performed.
2. Continuous measurements end when IN5 is turned OFF.

## Settings

► **[In/Out] – [I/O setting] – [I/O terminals] – [Input] – [Input mode]**

Press [Expanded mode].

## Sample Ladder Program

The following sample program is used to input a IN5 signal to perform continuous measurements. Continuous measurements will be started when W0.00 turns ON and stopped when W0.01 turns ON.

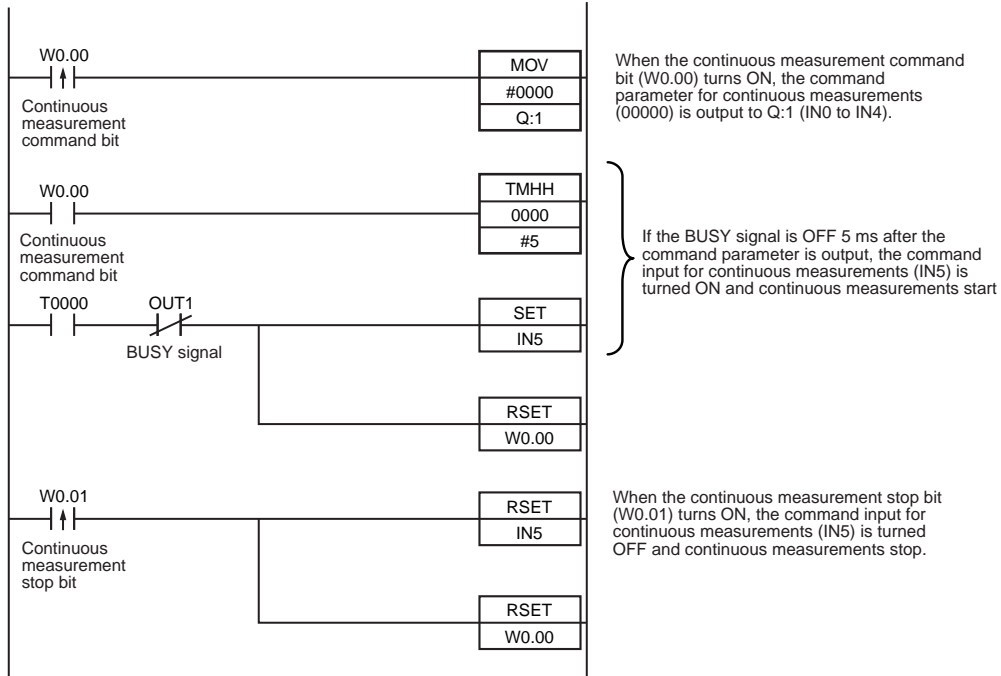

### • I/O Signal Allocations

Signal		Address
Output signals	OUT1 (BUSY signal)	CIO 0.01
Input signals	IN0	CIO 1.08
	IN1	CIO 1.09
	IN2	CIO 1.10
	IN3	CIO 1.11
	IN4	CIO 1.12
	IN5	CIO 1.15

## Setting the Outputs

### Using the Overall Judgement Result

When the results of the inspection items are judged, if even one individual judgement result is NG, the OR output signal is turned ON.

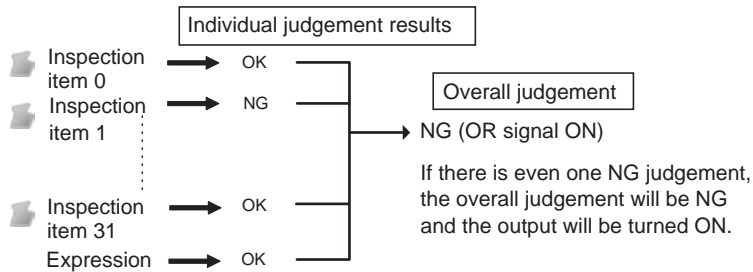

#### Note

- The overall judgement result output signal can also be turned ON when all individual judgement results are OK.
  - 📖 Changing the judgement output ON condition: p. 244
- You can select whether to include the judgement result of one of the expressions (0 through 31) in the overall judgement.
  - 📖 Using Calculation Results without Applying Them to the Overall Judgement: p. 161
- You can adjust the timing for outputting the OR signal and the ON time after judgement processing.
  - 📖 Adjust the Judgement Output Timing: p. 242

### Wiring

Color	Signal	Description
Black	OUT0 (OR)	Overall judgement (default assignment)

The signals shown at the left are used. Refer to the following information for signal wiring.

📖 2-4 Wiring: p. 42

### Timing Chart

The OR signal that is output is held until the next overall judgement is output.

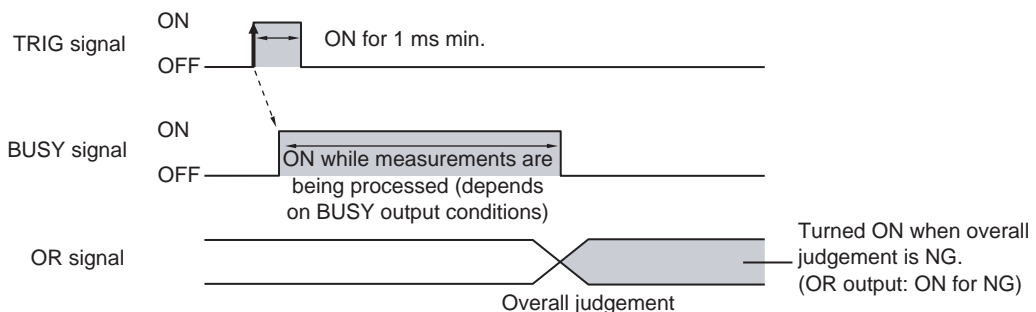

**Note**

The timing for updating the OR signal and the ON time after judgement processing can be adjusted.



Adjusting the judgement output timing: p. 242

## Getting Individual Judgements and Expression Judgements

Up to three judgement results of individual inspection items (item judgement signals OR0 to OR31) and expression judgements (expression 0 judgement to expression 31 judgement) can be assigned to terminals OUT0 to OUT2 and output to external devices.

Output terminal	Default assignment	Output signals that can be assigned
OUT0	OR (Total judgement)	<ul style="list-style-type: none"> <li>Control signals: OR, BUSY, ERROR, READY, and RUN STG (strobe trigger)</li> <li>Item judgements: OR0 (Item 0 judgement) to OR31 (Item 31 judgement)</li> <li>Expression judgements: Expression 0 judgement to expression 31 judgement</li> </ul>
OUT1	BUSY	
OUT2	ERROR	

**Note**

The timing for updating the OR0 to OR31 signals and the ON time after judgement processing can be changed.



Adjusting the judgement output timing: p. 242

## Wiring

Example: Signals are assigned to terminals OUT0 to OUT2 as shown below.

- OUT0: Item 2 judgement (OR2)
- OUT1: Item 5 judgement (OR5)
- OUT2: Item 14 judgement (OR14)

Color	Signal	Description
Black	OUT0 (OR2)	Outputs the judgement for OR2.
Orange	OUT1 (OR5)	Outputs the judgement for OR5.
Light blue	OUT2 (OR14)	Outputs the judgement for OR14.

The signals shown at the left are used.  
Refer to the following information for signal wiring.



2-4 Wiring: p. 42

As described above, if terminals OUT0 to OUT2 are all assigned to individual judgement output signals, the BUSY signal and ERROR signal assigned as the default settings will no longer be output.

## Timing Chart

Output OR0 to OR31 signals are held until the next judgement output.

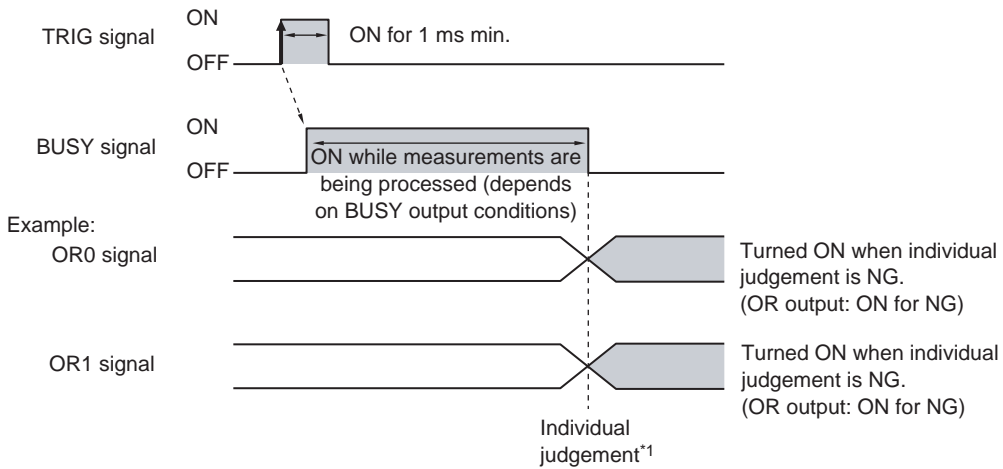

\*1: The timing for updating the OR signal is when the measurement results are finalized, regardless of the output settings of the BUSY signal (BUSY output conditions).

## Settings

### ► [In/Out] – [I/O setting] – [I/O setting] – [Output]

- 1 Press [OUT0].
- 2 Press [OR2 (Item 2 judgement)].  
OR2 output signal was assigned to OUT0.
- 3 Assign the others in the following manner.  
OUT1: OR5  
OUT2: OR14

## Adjusting the Judgement Output Timing

The output timing of the OR signal or OR0 to OR31 signals can be selected from two modes depending on the external device.

### Selecting the OFF Timing

- Level output (default)

The status of the output OR signal is held until the next OR signal is output.

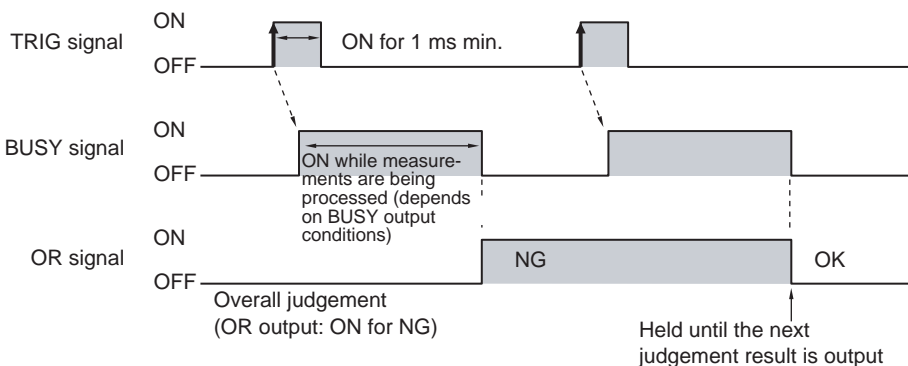



- One-shot output

The status of the output OR signal is turned OFF after a specified time has passed. (Setting range: 0 to 1,000 ms)

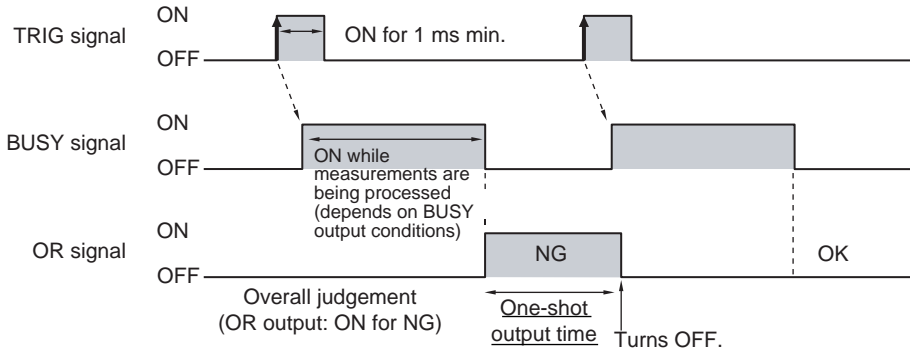

### Delaying the Output Timing

When using one-shot output, the output timing of the OR signal can be delayed. (Setting range: 0 to 1,000 ms)

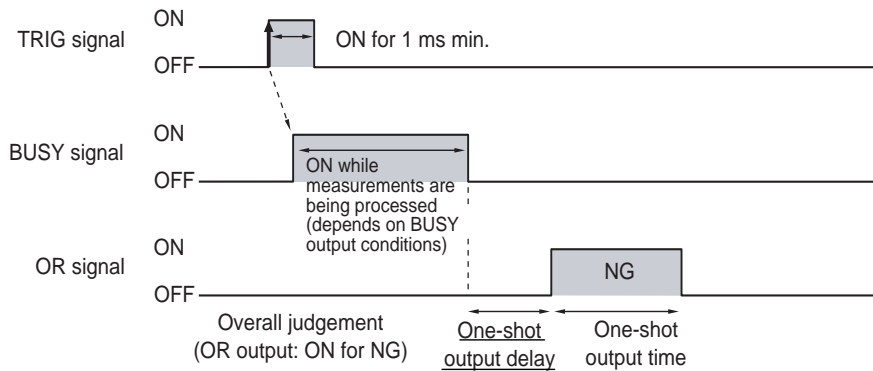

### Settings

► [In/Out] – [I/O setting] – [I/O setting] – [Output]

- 1 Press [Output mode] and press [Level output] or [One-shot output].
- 2 Press [Output delay] and set the one-shot output delay.
- 3 Press [OK].
- 4 Press [Output time] and set the one-shot output time.
- 5 Press [OK].

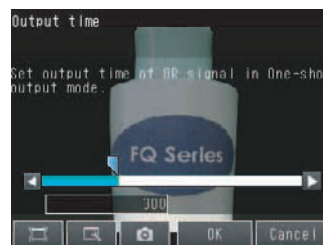
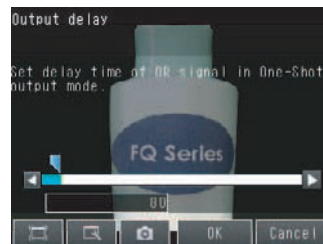

Item		Description
Output mode	One-shot output	After the measurement results are finalized, if the judgement output ON condition is met, the OR signal is turned ON for the one-shot output time. It is then turned OFF once the specified time has expired.
	Level output (default)	The judgement is output after measurement results are finalized and the ON/OFF status of the OR signal is held until it is changed for the next measurement result.
Output delay		When one-shot output mode is selected, this parameter sets the delay from when a measurement is completed until when the OR signal turns ON. (Setting range: 0 to 1,000 ms)
Output time		When one-shot output mode is selected, this parameter sets the time that the OR signal is ON. (Setting range: 1 to 1,000 ms)

### Important

When one-shot output is selected as the output mode, make the following value smaller than the trigger input period.

- One-shot delay time + One-shot output time

## Changing the Judgement Output ON Conditions

The ON condition for the OR signal or the OR0 to OR31 signals can be set to be output when the judgement results are OK or when they are NG. The default setting is when they are NG.

### Settings

#### ► [In/Out] – [I/O setting] – [I/O setting] – [Output] – [OR output]

Item		Description
OR output	OK: ON	The output is turned ON if the judgement is OK. For the overall judgement, the output is turned ON if all judgements are OK.
	NG: ON (default)	The output is turned ON if the judgement is NG. For the overall judgement, the output is turned ON if even one judgements is NG.

## Changing the Polarity of the BUSY Output

The Sensor turns ON the BUSY output signal during measurements and other processing to indicate that a measurement trigger cannot be received. The polarity of the BUSY signal can be reversed so that it is ON only when a trigger signal can be received.

In the default settings, the BUSY signal is assigned to OUT1. If you change the assignment of the BUSY signal, change the polarity of the corresponding output.

### Settings

#### ► [In/Out] – [I/O setting] – [I/O setting] – [Output] – [OUT1 Polarity]

Item		Description
OUT1 Polarity	Positive (default)	The BUSY signal is ON while the Sensor is processing data.
	Negative	The BUSY signal is ON while the Sensor can receive a trigger signal.

### Important

All timing charts in this manual show the operation of the BUSY signal with positive polarity (the default setting). If you change the polarity of the BUSY signal, take this into consideration when reading the timing charts.

## Adjusting the End Timing of the BUSY Signal

The end timing of the BUSY signal can be changed.

### ► [In/Out] – [I/O setting] – [I/O setting] – [Output] Tab Page – [BUSY output]

Item		Description
BUSY output	Measurement (default)	The BUSY signal turns OFF when the measurement is completed.
	Data logging	The BUSY signal turns OFF when data logging is completed.
	Image logging	The BUSY signal turns OFF when image logging is completed.
	Result display	The BUSY signal turns OFF when the result display is completed.

#### Important

Do not disconnect the Ethernet cable between the Sensor and the Touch Finder if the Sensor and Touch Finder are connected through an Ethernet switch and the BUSY output condition is set to [Data logging], [Image logging], or [Result display].

The Sensor will wait for the Touch Finder to answer, and the results and measurement time will be affected.

To disconnect the Sensor and Touch Finder during measurements in the above situation, clear the selection of the Sensor from the list of Sensors on the Touch Finder before you disconnect the cable.

## Changing the Polarity of the Output Signals

You can change the polarity of the output signals that are assigned to OUT0 to OUT3 (regardless of what signal is assigned to the output).

### Settings

#### ► [In/Out] – [I/O setting] – [I/O setting] – [Output] – [OUT0 Polarity], [OUT1 Polarity] or [OUT2 Polarity]

Item		Description
OUT0 Polarity, OUT1 Polarity, or OUT2 Polarity	Positive (default)	The output signal that is assigned to OUT0 to OUT3 is turned ON when the Sensor is executing a process.
	Negative	The output signal that is assigned to OUT0 to OUT3 is turned ON when the Sensor can receive the trigger.

## Controlling the Sensor from an External Device

The following Sensor functions can be controlled with command inputs from an external device without connecting the Touch Finder.

Function	Description	Reference
Switching the scene	This command changes the scene when the line process changes.	p. 246
Re-registering the model or reference color	This command re-registers the judgement references for measurement when levels are changed.	p. 249
Clearing an error	This command turns the ERROR signal OFF.	p. 251
Continuous measurement	Continuous measurement is performed while this command is input.	p. 237
Clearing measurement values	This command clears the measurement values.	p. 252
Saving data in the Sensor	This command saves the settings data to the Sensor.	p. 253
External teaching	This command executes teaching for all applicable inspection items.	p. 254

### Important

Change to Expanded Mode before you input any command other than a command to change the scene. If you change to Expanded Mode, you can use any of the commands. However, in Expanded Mode, you can change to only 16 scenes with the parallel SCENE command instead of 32 scenes.

## Changing the Scene

This section describes how to change the line process by changing the scene.

### Wiring

Color	Signal	State		Description
		Input Mode		
		Standard Mode	Expanded Mode	
Gray	IN0	Scene number (0 to 31)	Scene number (0 to 15)	Specifies the scene number. IN0 to IN4 correspond to the binary bits of the scene number. To change to scene 1 in Standard Mode, specify 00001.
Green	IN1			
Red	IN2			
White	IN3			
Purple	IN4	ON		
Yellow	IN5	ON		Trigger to change the scene
Orange	OUT1 (BUSY)	--		Processing in progress (default)

The signals shown at the left are used.  
Refer to the following information for signal wiring.



2-4 Wiring: p. 42

## Timing Chart

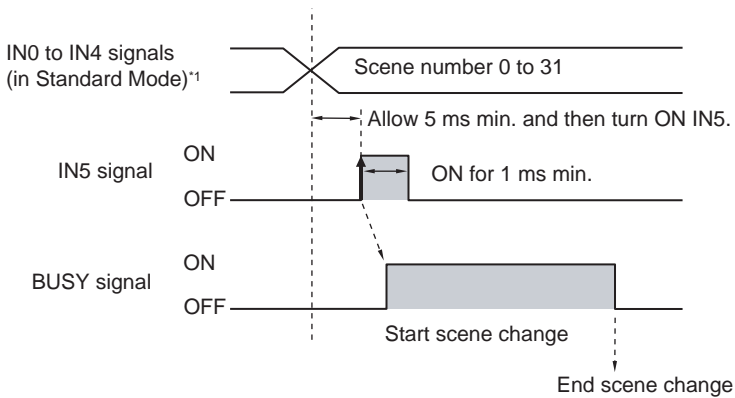

\*1: In Expanded Mode, specify scene numbers 0 to 15 using the IN0 to IN3 signals.

- 1 Specify the scene number with the IN0 to IN4 signals. (Standard Mode)
- 2 Turn ON the IN5 signal while the BUSY signal is ON to change the scene to the specified scene.
- 3 The BUSY signal turns ON while the scene is being switched.

## Settings

### ► [In/Out] – [I/O setting] – [I/O setting] – [Input] – [Input mode]

The scene numbers that can be used depend on the input mode.

[Standard mode] (default): Scene 0 to 31

[Expanded mode]: Scene 0 to 15

#### Note

Even in Expanded Mode, you can use menu commands or Ethernet no-protocol commands to change to scenes 0 to 31.

## Sample Ladder Program

This sample program is used to change the scene when the input mode is set to Expanded Mode. The scene changes to scene 1 when W0.00 turns ON.

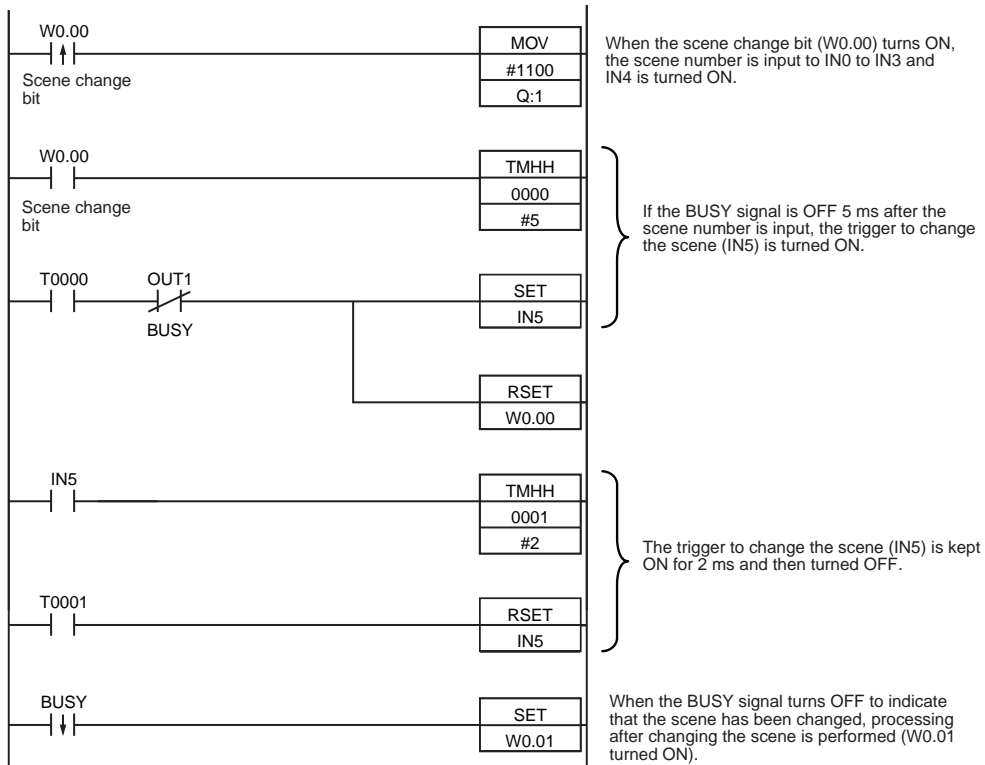

### • I/O Signal Allocations

Signal	Address
Output signals	OUT1 (BUSY signal) CIO 0.01
Input signals	IN0 CIO 1.08
	IN1 CIO 1.09
	IN2 CIO 1.10
	IN3 CIO 1.11
	IN4 CIO 1.12
	IN5 CIO 1.15

#### Note

The BUSY signal will be ON while the scene it being changed.

#### Important

If the cycle time is too long, the PLC may not be able to detect when the BUSY signal is ON. If necessary, turn OFF W0.00 after a suitable time elapses.

## Registering the Measurement Reference Again

The model and reference color can be re-registered with commands from an external device, such as a PLC, based on the image that was just input when the line process was changed.

Inspection item	Re-registered data
Search, Shape Search II	Model data
Color Data	Reference color (hue, saturation, and brightness)
Edge Position, Edge Width, Area	None

### Note

- Application is possibly only from the Run Mode
- If the parameter is applicable to more than one inspection item, it will be re-registered for all inspection items.

## Settings

### ► [In/Out] – [I/O setting] – [I/O setting] – [Input] – [Input mode]

Press [Expand mode].

## Wiring

Color	Signal	State	Description
Gray	IN0	OFF	Command parameter for registering the model again
Green	IN1	OFF	
Red	IN2	OFF	
White	IN3	ON	
Purple	IN4	OFF	
Yellow	IN5	ON	Command input for registering the model again
Orange	OUT1 (BUSY)	--	Processing in progress (default)

The signals shown at the left are used.

Refer to the following information for signal wiring.

 2-4 Wiring: p. 42

## Timing Chart

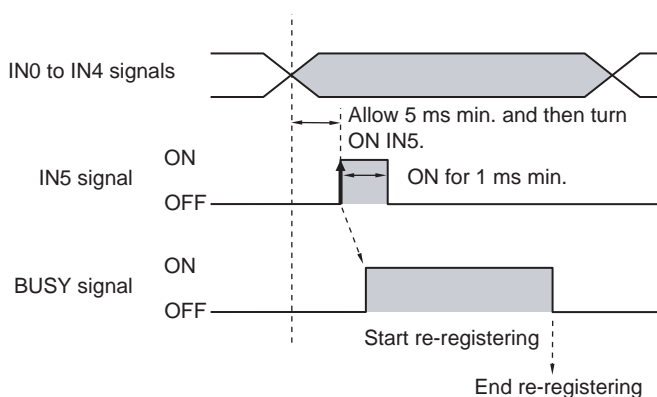

- 1 Turn OFF IN 0 to IN4 and turn ON IN3.
- 2 Turn ON the IN5 signal while the BUSY signal is OFF to register the model data and reference color again from the image that was just input.
- 3 The BUSY signal turns ON while the parameters are being re-registered.

## Sample Ladder Program

This sample program is used to input IN5 to re-register a model.

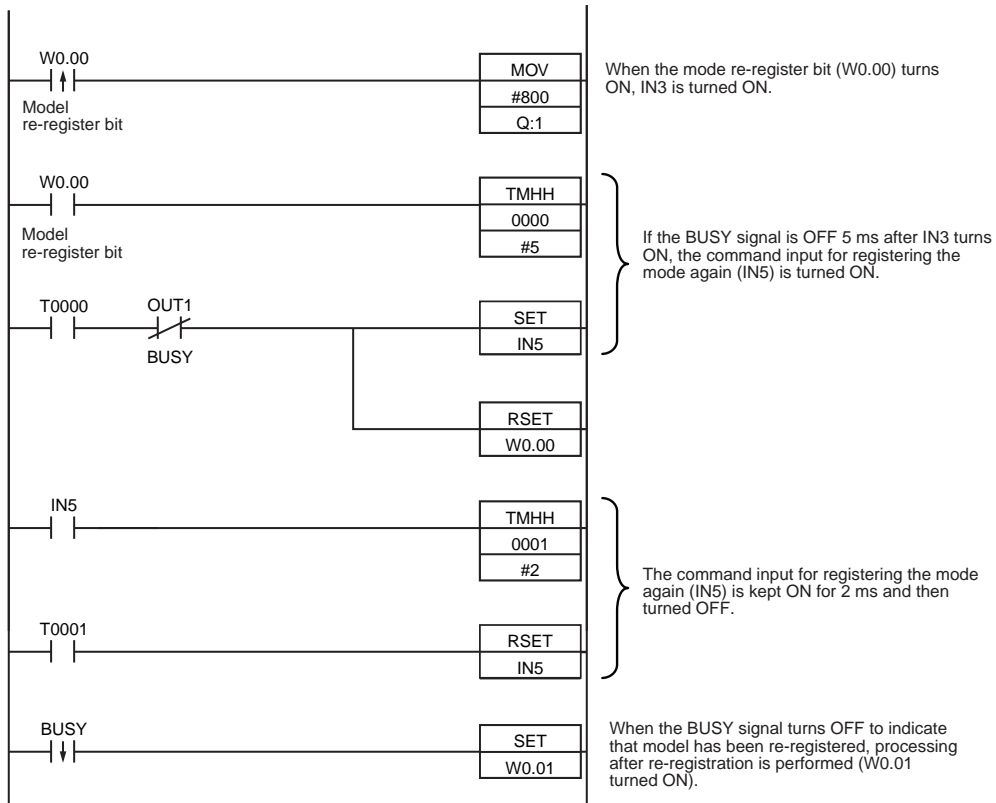

### • I/O Signal Allocations

Signal		Address
Output signals	OUT1 (BUSY signal)	CIO 0.01
Input signals	IN0	CIO 1.08
	IN1	CIO 1.09
	IN2	CIO 1.10
	IN3	CIO 1.11
	IN4	CIO 1.12
	IN5	CIO 1.15

#### Note

The BUSY signal will be ON while the model is being re-registered.

#### Important

If the cycle time is too long, the PLC may not be able to detect when the BUSY signal is ON. If necessary, turn OFF W0.00 after a suitable time elapses.



## Turning the ERROR Signal OFF

The ERROR signal turns ON when an error occurs.

After removing the cause of the error, turn the ERROR signal OFF using one of the following methods.

Method 1: Input an error clear command from an external device such as a PLC.

Method 2: Input a measurement trigger again.

(For example, turn the TRIG signal ON during a one-shot measurement.)

The ERROR signal will turn OFF when measurement is executed correctly.

### Note

This function can be used in Run Mode only.

## Settings

► **[In/Out] – [I/O setting] – [I/O setting] – [Input] – [Input mode]**

Press [Expand mode].

## Wiring

Color	Signal	State	Description
Gray	IN0	OFF	Command parameter for clearing errors
Green	IN1	OFF	
Red	IN2	ON	
White	IN3	OFF	
Purple	IN4	OFF	
Yellow	IN5	ON	Command input for clearing errors
Orange	OUT1 (BUSY)	--	Processing in progress (default)
Light blue	OUT2 (ERROR)	--	ERROR signal (default)

The signals shown at the left are used.

Refer to the following information for signal wiring.

 2-4 Wiring: p. 42

## Timing Chart

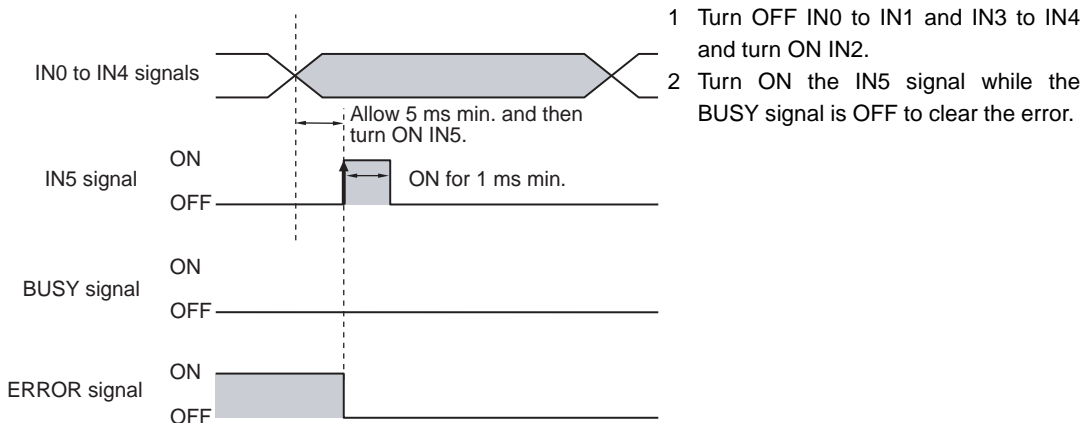

## Clear Measurement Values

This command clears the measurement values that are stored in the Sensor. However, the OR signal and the output signals that are assigned to OUT0 to OUT2 are not cleared.

### Note

This function can be used in Run Mode only.

## Settings

► **[In/Out] – [I/O setting] – [I/O setting] – [Input] – [Input mode]**

Press [Expand mode].

## Wiring

Color	Signal	State	Description
Gray	IN0	ON	Command parameter for clearing measurement values
Green	IN1	OFF	
Red	IN2	ON	
White	IN3	OFF	
Purple	IN4	OFF	
Yellow	IN5	ON	Command input for clearing measurement values
Orange	OUT1 (BUSY)	--	Processing in progress (default)

The signals shown at the left are used.

Refer to the following information for signal wiring.

 2-4 Wiring: p. 42

## Timing Chart

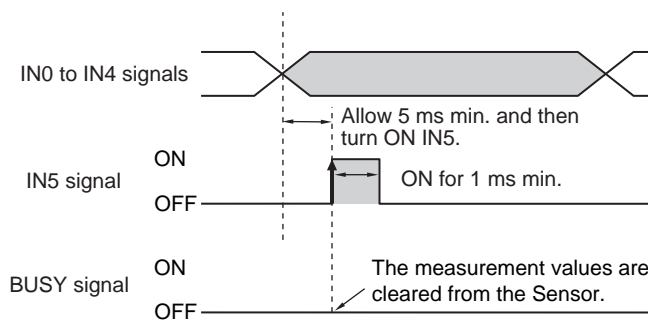

- 1 Turn ON IN0 and IN2 and turn OFF IN3 and IN4.
- 2 Turn ON the IN5 signal while the BUSY signal is OFF to clear the measurement values.

## Save Data in Sensor

You can save the current settings (scene data and system data) in the Sensor.

### Note

This function can be used in Run Mode only.

## Settings

► **[In/Out] – [I/O setting] – [I/O setting] – [Input] – [Input mode]**

Press **[Expand mode]**.

## Wiring

Color	Signal	State	Description
Gray	IN0	ON	Command parameters for saving data to the Sensor
Green	IN1	OFF	
Red	IN2	OFF	
White	IN3	OFF	
Purple	IN4	OFF	
Yellow	IN5	ON	Command input for saving data to the Sensor
Orange	OUT1 (BUSY)	--	Processing in progress (default)

The signals shown at the left are used.

Refer to the following information for signal wiring.

 2-4 Wiring: p. 42

## Timing Chart

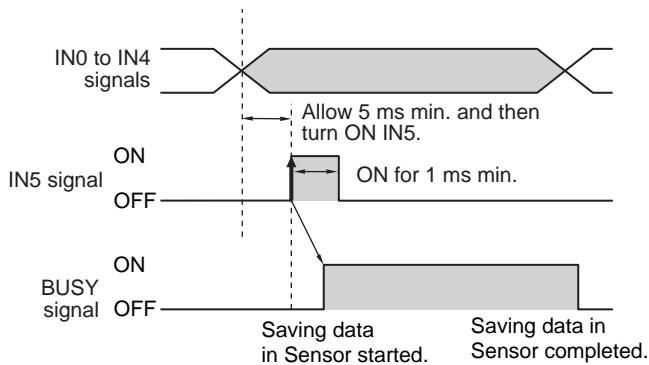

- 1 Turn ON IN0 and turn OFF IN1 to IN4.
- 2 Turn ON the IN5 signal while the BUSY signal is OFF to save the data in the Sensor.

## Executing External Teaching

You can use the image that is currently being input to execute teaching for all of the registered inspection items.

### Note

- Application is possibly only from the Run Mode
- If the parameter is applicable to more than one inspection item, it will be external teaching for all inspection items.

## Settings

► **[In/Out] – [I/O setting] – [I/O setting] – [Input] – [Input mode]**

Press [Expand mode].

## Wiring

Color	Signal	State	Description
Gray	IN0	ON	Command parameter for external teaching
Green	IN1	OFF	
Red	IN2	OFF	
White	IN3	ON	
Purple	IN4	OFF	
Yellow	IN5	ON	Command input for external teaching
Orange	OUT1 (BUSY)	--	Processing in progress (default)

The signals shown at the left are used.

Refer to the following information for signal wiring.

 2-4 Wiring: p. 42

## Timing Chart

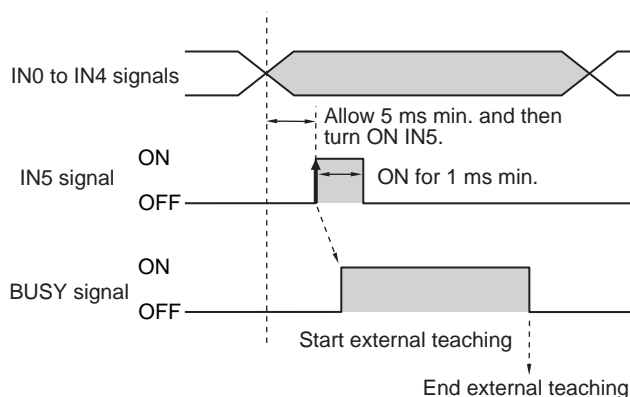

- 1 Turn ON IN0 and IN3 and turn OFF IN1, IN2, and IN4.
- 2 Turn ON the IN5 signal while the BUSY signal is OFF to execute external teaching.
- 3 The BUSY signal turns ON while external teaching is being executed.

## Sample Ladder Program

This sample program is used to input IN5 to external teaching.

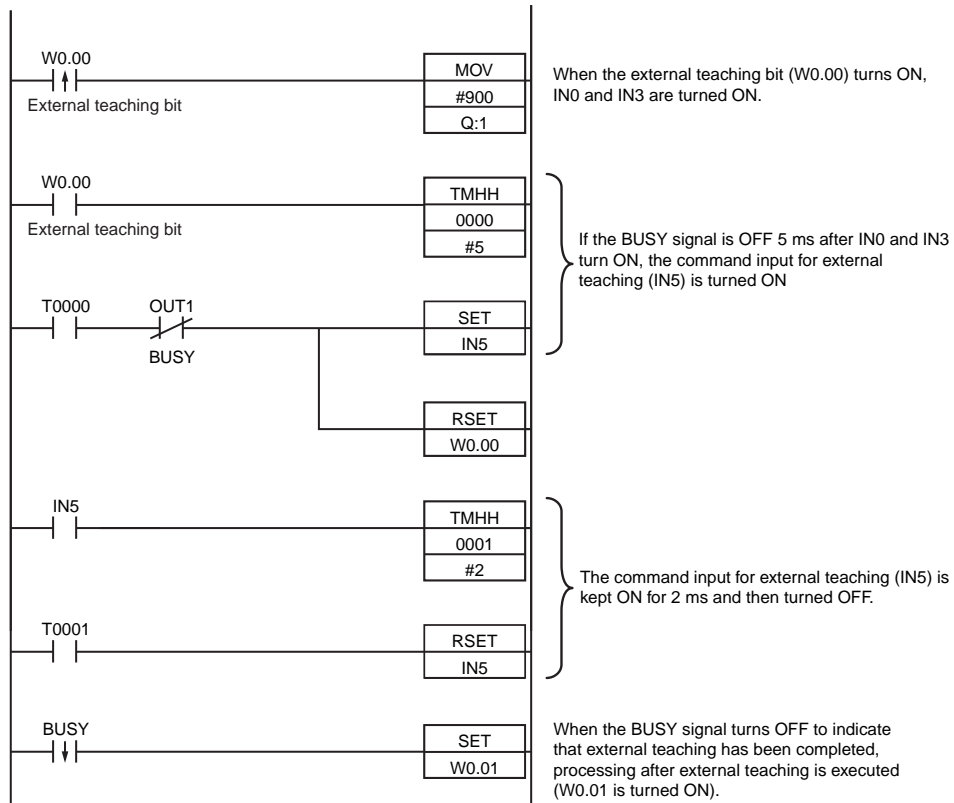

### • I/O Signal Allocations

Signal		Address
Output signals	OUT1 (BUSY signal)	CIO 0.01
Input signals	IN0	CIO 1.08
	IN1	CIO 1.09
	IN2	CIO 1.10
	IN3	CIO 1.11
	IN4	CIO 1.12
	IN5	CIO 1.15

#### Note

The BUSY signal will remain ON while external teaching is being executed.

#### Important

If the cycle time is too long, the PLC may not be able to detect when the BUSY signal is ON. If necessary, turn OFF W0.00 after a suitable time elapses.

## 8-2 Controlling Operation and Outputting Data with a Parallel Interface Sensor Data Unit

### Overview

If you mount a Parallel Interface Sensor Data Unit, in addition to outputting OR judgement results, you can also use the Parallel Interface Sensor Data Unit to output the judgement results of judgement conditions that you set for parallel output (called parallel judgement output) and the results of measurement values and expressions for inspection items (called parallel data output).

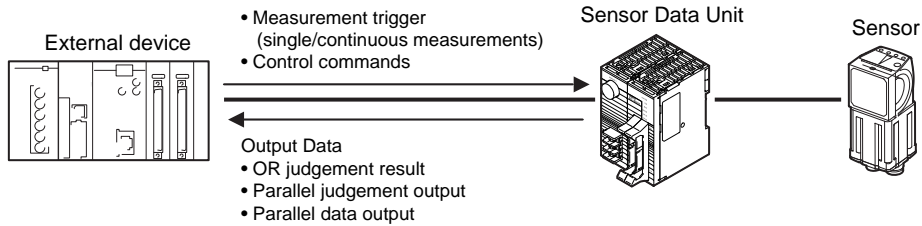

### Setting the Measurement Trigger

The measurement trigger can be chosen from the following two types:

- Single measurement: One measurement is performed for each external trigger.
- Continuous measurement: Measurements are performed continuously.

Refer to the following page for data output timing and signal status after measurement trigger execution.

 [Aligning the Data Output Timing with the External Device: p. 262](#)

### Performing One Measurement for Each External Trigger

A measurement trigger is input as the TRIG signal from a proximity sensor, PLC, or other external device. One measurement is performed when the TRIG signal turns ON.

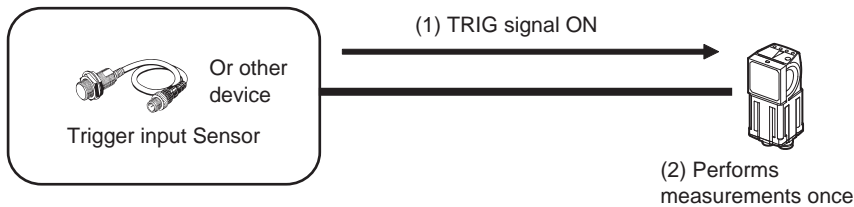

## Performing Continuous Measurements

Continuous measurements are performed while the continuous measurement command is input from an external device.

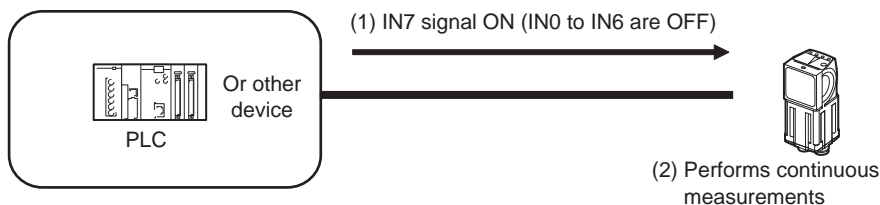

## Setting Output Data

You can set the data to output after measurements.

### Output Data

You can output any of the following data through the Parallel Interface Sensor Data Unit.

Data	Output contents	Signal used to output the data
OR signal	Overall judgement result	The results is output with the OR signal.
Parallel judgement output	Judgement results of the judgement conditions that are set for parallel output	The results are assigned to and output with D0 to D15.
Parallel data output	Measurement values for inspection items and results from expressions	The data is output as 16-bit data on D0 to D15.

### Outputting the Overall Judgement Result (OR Signal)

When the results of the inspection items are judged, if even one individual judgement result is NG, the OR output signal is turned ON.

#### Note

- You can also turn ON the overall judgement result output signal when all individual judgement results are OK.
  - Changing the Judgement Output ON Conditions: p. 244
- You can select whether to use the judgement result of one of the calculations (0 through 31) as the overall judgement.
  - Using Calculation Results without Applying Them to the Overall Judgement: p. 161
- You can adjust the timing for outputting the OR signal and the ON time after judgement processing.
  - Adjusting the Judgement Output Timing: p. 242

## Parallel Judgement Outputs

You can set judgement conditions for parallel output and then output the judgement results for those conditions.

### ● Setting the Items to Judge and the Judgement Conditions

You can assign up to 16 judgement results to and output them from the D0 to D15 signals.

As the items to judge, you can specify the measurement data from inspection items that can be output and the calculation results from the expression settings.

Use the following procedure to set the items to judge and the judgment conditions.

#### (1) Setting the Items to Judge

You can assign the parameters from the inspection items to the data output signals (D0 to D15).

The following procedure shows how to assign the measured position X of [0. Search] to D0.

### ▶ [In/Out] – [I/O setting] – [Output data set] – [Par. Jdg Output] – [Basic] Tab Page

- 1 Press [Settings].
- 2 Press [IO.D0].
- 3 Press [IO. Search].
- 4 Press [Position X X].

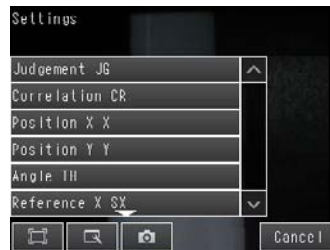

- 5 If the inspection item allows multi-point output, press the number ([0] to [30]) of the inspection result for which to output the data from the list of inspection results.

To register something to D1 or higher, repeat this process.

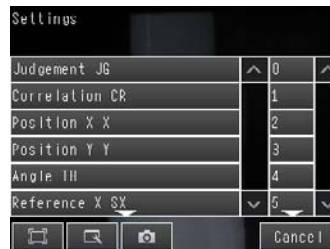

#### (2) Setting the Judgement Conditions

### ▶ [In/Out] – [I/O setting] – [Output data set] – [Par. Jdg Output] – [Basic] Tab Page

- 1 Press [Judgement condition].
- 2 Set the correlation range that is to be judged as OK.

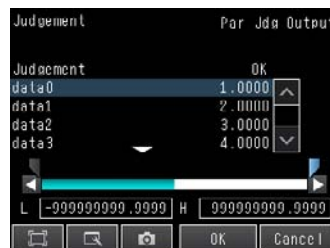



- Reflecting Judgement Results to the Overall Judgement

You can specify whether to reflect the judgement result of a parallel judgement output in the overall judgement. (The default is to reflect them.)

▶ **[In/Out] – [I/O setting] – [Output data set] – [Par. Jdg Output] – [Details] Tab Page – [Output parameter] – [Reflect]**

- Stopping Data Output

You can also prevent the judgement results that are set from actually being output. (The default setting is [Yes].)

▶ **[In/Out] – [I/O setting] – [Output data set] – [Par. Jdg Output] – [Details] Tab Page – [Output parameter] – [Data output]**

- Measurement Data That Can Be Used for External Outputs and Calculations

The following values can be used as measurement data and output to external devices via Ethernet or used in calculations.

Expression text string	Data name	Description	Data range
JG	Judgement	This is the judgement result.	0: Judgement is OK -1: Judgement is NG -13: Teaching not performed error -14: Figure not registered error -15: Out of range error
D0 to D15	Data 0 to 15	These are the results of the expressions that are set for output judgement data 0 to 15.	-999,999,999.9999 to 999,999,999.9999
J00 to J15	Judgments 0 to 15	These are the judgement results of the expressions that are set for output judgement data 0 to 15.	0: OK -1: NG -2: Not measured.

## Parallel Data Output

You can output the following data as 16-bit data by setting them as the output data (data 0 to data 31): measurement data from inspection items that can be output and the calculation results from the expression settings.

- Setting the Data to Output

You can individually assign the parameters of the inspection items to output data (data 0 to data 31).

The following procedure shows how to assign the measured position X of [0. Search] to data 0 for a parallel output.

▶ **[In/Out] – [I/O setting] – [Output data set] – [Par. Jdg Output] – [Basic] Tab Page**

- 1 Press [Data settings].
- 2 Press [Data 0].
- 3 Press [I0. Search].
- 4 Press [Position X X].

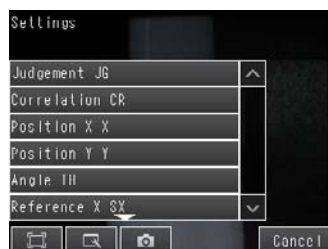

**5** If the inspection item allows multi-point output, press the number ([0] to [31]) of the inspection result for which to output the data from the list of inspection results.

To register something to data 1 or higher, repeat this process.

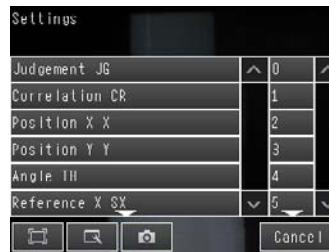

● Setting the Output Form

▶ **[In/Out] – [I/O setting] – [Output data set] – [Par. Jdg Output] – [Basic] Tab Page**

- 1** Press [Output format].
- 2** Press [Output form].
- 3** Set [Data form] to [Binary] or [BCD].

● Stopping Data Output

You can also prevent the output data that is set from actually being output. (The default setting is [Yes].)

▶ **[In/Out] – [I/O setting] – [Output data set] – [Parallel Data Output Setting] – [Details] Tab Page – [Output parameter] – [Data output]**

● Measurement Data That Can Be Used for External Outputs and Calculations

The following values can be used as measurement data and output to external devices via Ethernet or used in calculations.

Expression text string	Data name	Description	Data range
JG	Judgement	This is the judgement result.	0: Judgement is OK -1: Judgement is NG -13: Teaching not performed error -14: Figure not registered error -15: Out of range error
D0 to D31	Data 0 to 31	These are the values of the parameters that are set for output data 0 to 31.	-999,999,999.9999 to 999,999,999.9999

● Output Specifications

- Only the integer portions of numbers are output. All digits before the decimal point are rounded off.
- The following range of values can be output.  
Binary data: -32768 to 32768  
BCD data: -999 to 999

If the measurement value is out of range, the actual measurement value is not output and the minimum or maximum value of the range is output instead.

Data format	Measurement value that is below the possible output range	Measurement value that is above the possible output range
Binary data	A value of -32,767 is output.	A value of 32,768 is output.
BCD	A value of -999 is output.	A value of 999 is output.

**Note**

The data that is output to the OR and D signals after a measurement is held until the next measurement is performed. The values will continue to be output even after all measurements have been completed. However, if you set the output timing of the OR signal to [One-shot output] in the [Output mode] parameter, the OR signal will turn OFF after the specified output time has elapsed.

## Data Output Timing

● Output Sequence

If both parallel judgement output and parallel data output are performed at the same time, parallel judgement output will be performed first followed by parallel data output.

Example: Parallel Judgement Output of D0 to D15 and Parallel Data Output of Data 0

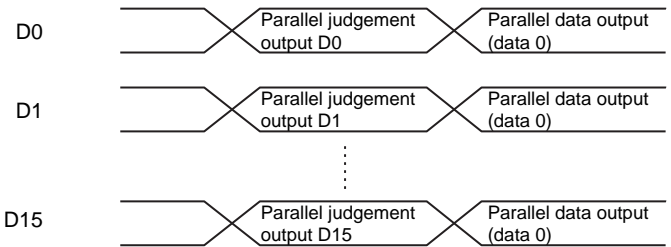

● Timing Chart

The following timing chart shows the data output timing for parallel judgement outputs.

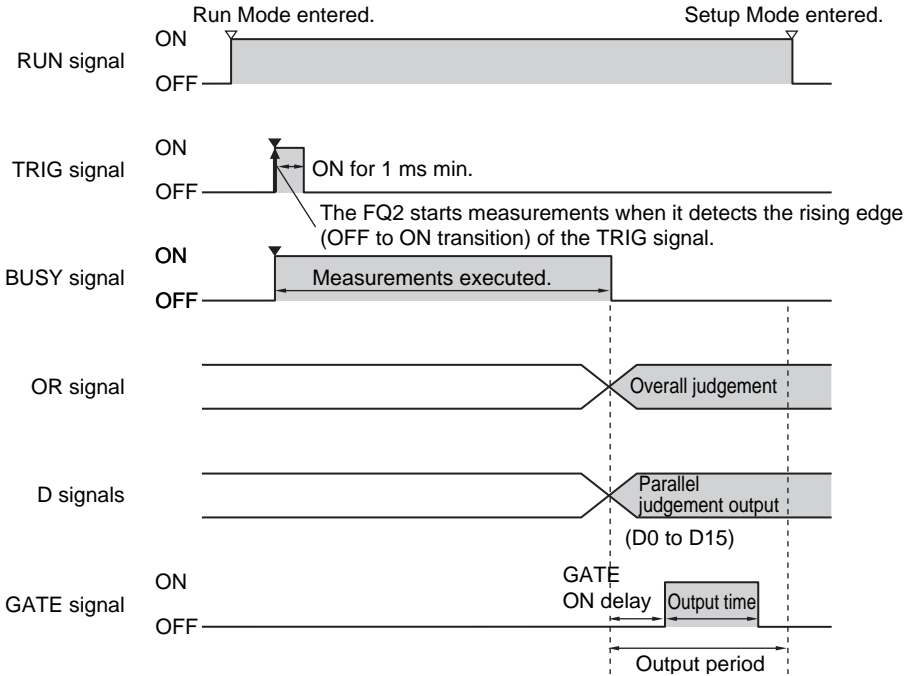

## Output Signals



Signal	Function
RUN	This signal is ON while the Sensor is ready to take measurement and it is in Run Mode. The RUN signal is OFF in Setup Mode. Change to Run Mode for operation.
BUSY	This signal is ON when the Sensor is performing measurements, changing scenes, or performing other tasks. Do not input the next command while the BUSY signal is ON. The process that is currently being executed and the command that is input will not be executed correctly.
OR	This signal outputs the overall judgement. The signal is valid when the measurements are completed (i.e., when the BUSY signal changes from ON to OFF).
D	These signals output the parallel judgement output data and the calculation results of the expressions that are set for parallel data output. You can set whether the signal turns ON for an OK or for an NG judgement in the [Judgment output condition] output setting.   Changing the Signal Specifications: p. 245
GATE	This signal is used to control the timing of reading the D signals at an external device. It is turned ON for the period of time that is required to reliably read the D signals at the external device. Set the output period so that the total output time is shorter than the measurement interval (i.e., the TRIG signal input interval). The GATE signal is output only if parallel judgement output and parallel data output are set. The OR signal will be ON while the TRIG signal can be input.

## Input Signals

Signal	Function
TRIG	This signal is used to input a measurement trigger from an external device, such as a photoelectric switch. One measurement is performed on the rising edge (OFF to ON transition) of the TRIG signal. Keep the TRIG signal ON for at least 1 ms.

## Aligning the Data Output Timing with the External Device



You can use one of the following data output methods to align the timing of data output with an external device.

- Aligning with the GATE Signal Status (No Handshaking):  p. 263
- Outputting Measurement Results for Data Send Requests from the External Device (Handshaking):  p. 266
- Offsetting the Timing of Outputting Measurement Results:  p. 268

## Setting Data Communications Specifications

### ▶ [In/Out] – [I/O setting] – [I/O setting] – [Output]

#### 1 Press [Output control] and select the output control method.

- None:  p. 263
- Handshaking  p. 266
- Synchronized Output:  p. 268

#### 2 Set the communications specifications for data output.

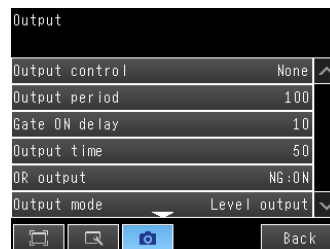

Item	Parameter	Description
Output control	None (default), Handshaking, or Sync. Output	None: Measurement results are output without synchronizing with the external device. Handshaking: Measurement results are output while synchronizing with the PLC. Sync. output: Measurement results are output without synchronizing with the external device.
Output period	2.0 to 5,000.0 ms 10.0 ms (default)	This setting is enabled only when the [Output control] parameter is set to [None]. Set the period for outputting measurement results. Set a value that is longer than the GATE ON delay plus the output time and shorter than the measurement interval. If you set a value that is longer than the measurement interval, the output timing will become delayed as measurements are repeated.
GATE ON delay	1.0 to 1,000.0 ms 1.0 ms (default)	Set the time from when the result is output to the parallel interface until the GATE signal turns ON. This is the time to wait until the data output stabilizes. Set a value that is longer than the delay time of the external device.
Output time	1.0 to 1,000.0 ms 5.0 ms (default)	This setting is enabled only when the [Output control] parameter is set to [None] or [Sync. output]. Set the time to turn ON the GATE signal. Set the time that is required for the external device to read the measurement results.
Timeout	0.5 to 120.0 s 10.0 s (default)	This setting is enabled only when the [Output control] parameter is set to [Handshaking]. A timeout error will occur at the following times if there is no response from the external device within the time that is set. When the DSA signal turns ON after measurements are completed When the DSA signal turns OFF after the GATE signal turns ON When the DSA signal turns ON after the GATE signal turns OFF
Number of delay	1 to 15 (default)	This setting is enabled only when the [Output control] parameter is set to [Sync. output]. Set the number of times to ignore the STEP signal turning ON between when the STEP signal turns ON and the measurement results are output.

## Reading Data When the GATE Signal Is Output (No Handshaking)

The Sensor will output the measurement results without synchronizing with the external device, but the GATE signal is also output.

The GATE signal is used to control the timing of when the external device reads the measurement data.

Adjust the external device so that it reads the measurement results when the GATE signal is output.

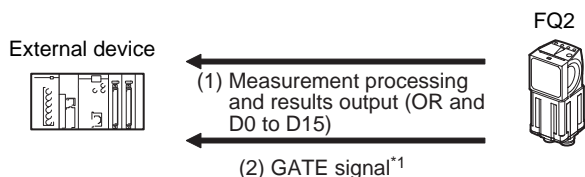

\*1 You can change the settings of when the GATE signal is turned ON after the measurement data is output and the length of time that the GATE signal will remain ON.  
 Setting the Output Timing for the GATE Signal: p. 262

### Note

The GATE signal will not be output if there is no data set for parallel judgement output and parallel data output.  
 If only the OR signal is output, read the OR signal when the BUSY signal turns OFF.

● Single Measurement

Example: Three Data Items Set for Parallel Data Output  
Timing Chart

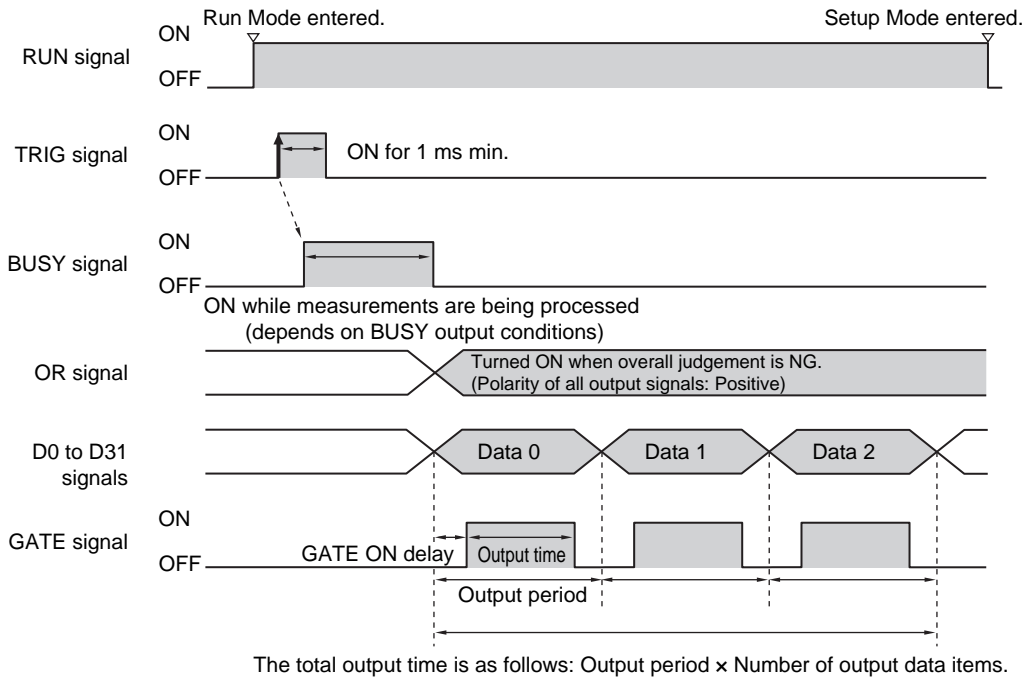

- 1** The RUN signal turns ON when measurements are enabled and the Sensor is in Run Mode.
- 2** Turn ON the TRIG signal while the BUSY signal is OFF.
- 3** Measurement begins and the BUSY signal is turned ON during the measurement process.
- 4** When the measurement has been finished, the measurement results are output using an OR signal and the D0 to D15 signals, and the BUSY signal is turned OFF.\*1

\*1 You can also set the [BUSY output] parameter so that the BUSY signal is turned OFF after the completion of data logging, image logging, or displaying results.

- 5** After the BUSY signal turns OFF, the GATE signal is turned ON when the time that is set in the [GATE ON delay] parameter in the communications settings has elapsed.\*2
- 6** The GATE signal is turned ON, and then the GATE signal is turned OFF when the time that is set in the [Output time] parameter in the communications settings has elapsed.\*2

\*2 Set the GATE ON delay and output time for the GATE signal so that the total time does not exceed the output period.

**Important**

Data Output Time and TRIG Signal Input Interval

Set the input interval for the TRIG signal so that it is equal to or greater than the total output time. If the input interval for the TRIG signal is shorter than the total output time, the output data buffer will eventually overflow and output data will be discarded.

● Continuous Measurements

Example: Only Data 0 Set for Parallel Data Output  
Timing Chart

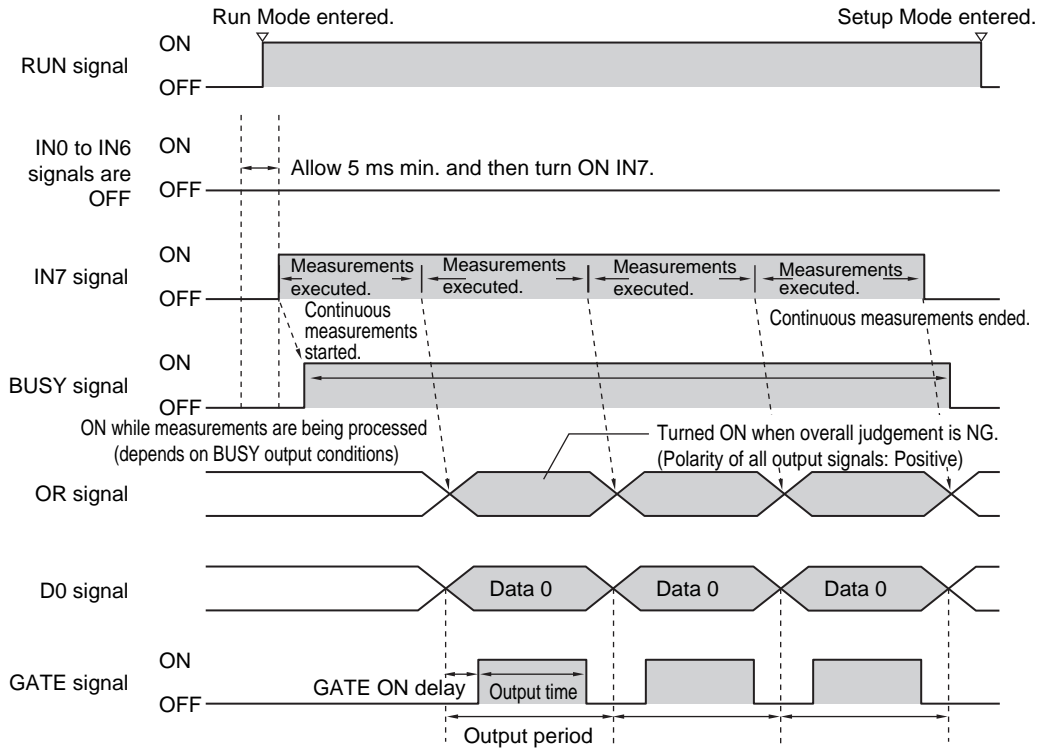

- 1** The RUN signal turns ON when measurements are enabled and the Sensor is in Run Mode.
- 2** Turn ON IN7 while IN0 to IN6 are OFF. If this status is held while the BUSY signal is OFF, continuous measurements will begin and the BUSY signal will remain ON while continuous measurements are being performed.
- 3** When measurement results are output, the GATE signal is turned ON when the time that is set in the [GATE ON delay] parameter in the communications settings has elapsed.\*1
- 4** The GATE signal is turned ON, and then the GATE signal is turned OFF when the time that is set in the [Output time] parameter in the communications settings has elapsed.\*1
- 5** Continuous measurements end when the IN7 signal is turned OFF.

\*1 Set the GATE ON delay and output time for the GATE signal so that the total time does not exceed the output period.

**Note**

The ERROR signal will turn ON if the input command is not executed normally.  
Set at least one data output for parallel judgement output and then read the OR signal when the GATE signal turns ON.

## Outputting Measurement Results for Data Send Requests from the External Device (Handshaking)

With handshaking, measurement results are output after there is a data send request (DSA signal) from the external device.

Handshaking is effective for sequentially outputting many measurement results and it is a reliable way to transfer data.

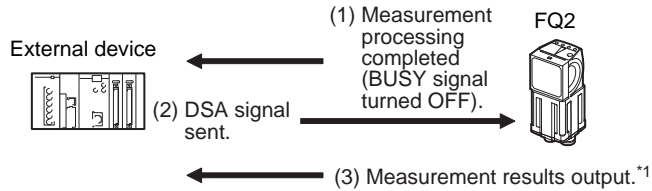

\*1 The overall judgement (OR) is output even if the DSA signal is not output by the external device.

### ● DSA Signal

The DSA signal is used by the external device to request the next data transmission. The Sensor will not output data until the DSA signal is turned ON. Turn ON the DSA signal at the following time.

- When the external device is ready to receive data
- When the Sensor has completed measurements

The BUSY signal will be ON while measurements are being executed. Therefore, you can monitor the status of the BUSY signal to detect when measurements have been completed.



● Timing Chart

Example: Three Data Items Set for Parallel Data Output

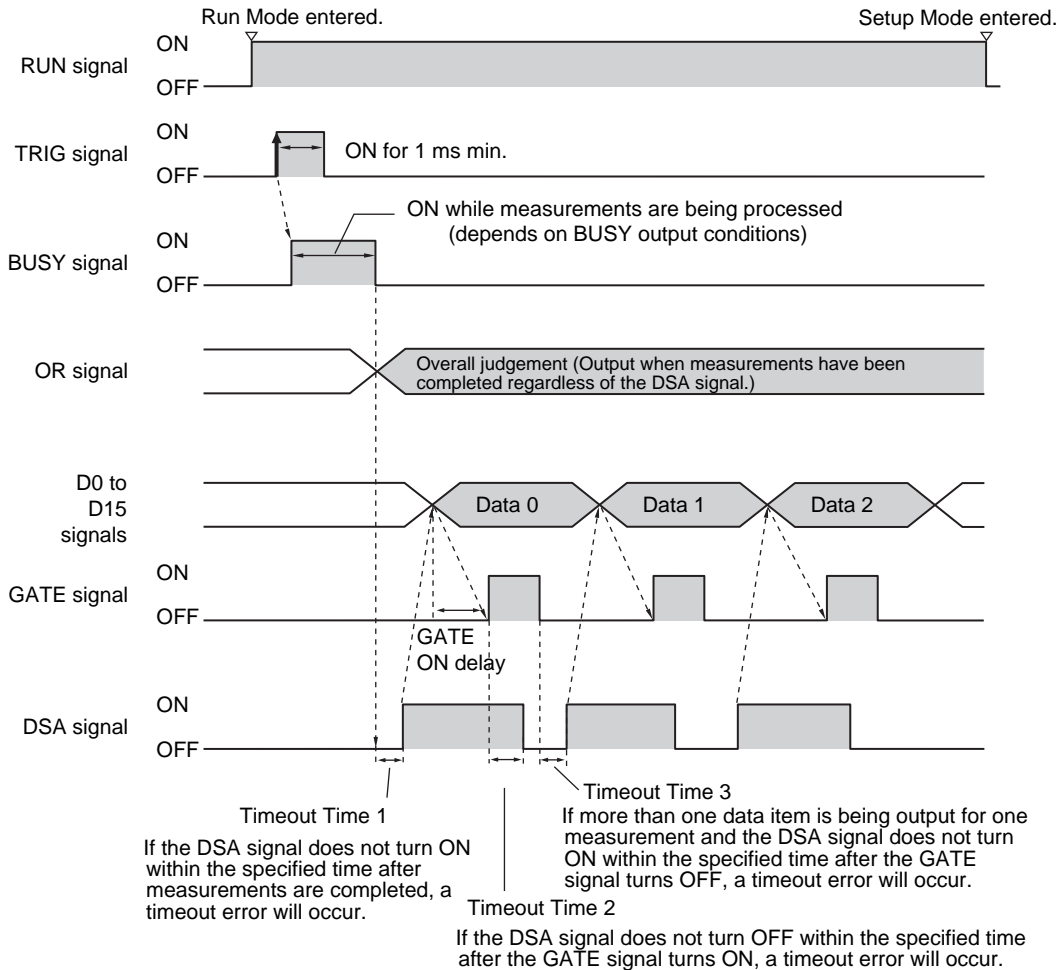

- 1** Turn ON the TRIG signal while the BUSY signal is OFF.
- 2** Measurement begins and the BUSY signal is turned ON during the measurement process.
- 3** When the measurement has been finished, the measurement result is output using an OR signal, and the BUSY signal is turned OFF.\*1

\*1 You can also set the [BUSY output] parameter so that the BUSY signal is turned OFF after the completion of data logging, image logging, or displaying results.

- 4** Turn ON the DSA signal from the external device to request data transmission after you have confirmed that the BUSY signal is OFF.\*2

\*2 If you do not turn ON the DSA signal within the specified timeout time after measurements are completed, a timeout error will occur. (This is timeout time 1.)

- 5** When the DSA signal turns ON, the D0 to D31 signals are output and the GATE signal is turned ON.

- 6** When the DSA signal is turned OFF, the GATE signal turns OFF.\*3

\*3 If you do not turn OFF the DSA signal within the specified timeout time after the GATE signal turns ON, a timeout error will occur. (This is timeout time 2.)

- 7** If more than one data item is being output for one measurement and you do not turn ON the DSA signal within the specified timeout time after the GATE signal turns OFF, a timeout error will occur. (This is timeout time 3.)

## Offsetting the Timing of Outputting Measurement Results

The measurement result is output when the TRIG signal turns ON the number of times set for the [Number of delay] parameter.

This allows you to delay the output timing of the measurement result from the Sensor according to the actual processing timing of the line.

Example: Sequential Feed Line That Uses a Star Wheel

In a line like this, you can synchronize the output timing of the measurement results and the discharge timing of NG products that are detected.

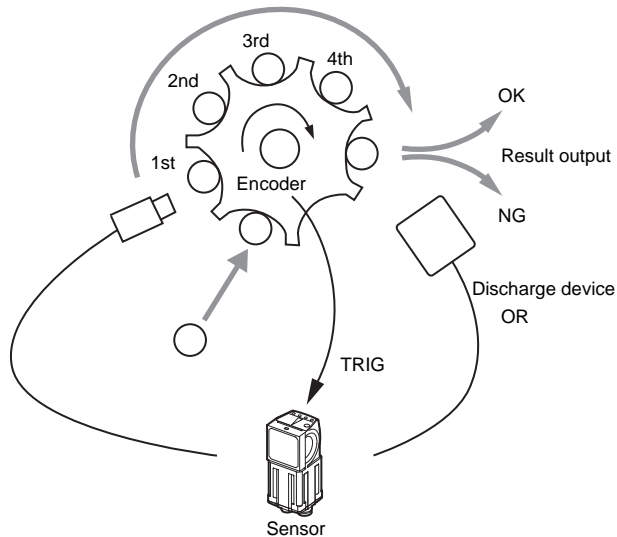

If you set the [Number of delay] parameter to 4, the measurement result output is delayed by four TRIG signals.

### Note

- With synchronized output, the number of times that the TRIG signal turns ON is counted. Therefore, use synchronized output only when only one measurement result is output for each measurement. (Output either the parallel judgement or data.)
- Use a measurement trigger only for single measurements.  
If you perform continuous measurements by inputting a command, the output timing will not be correct and the Sensor may malfunction.

● Timing Chart

Operation When [Number of Delay] Is Set to 2

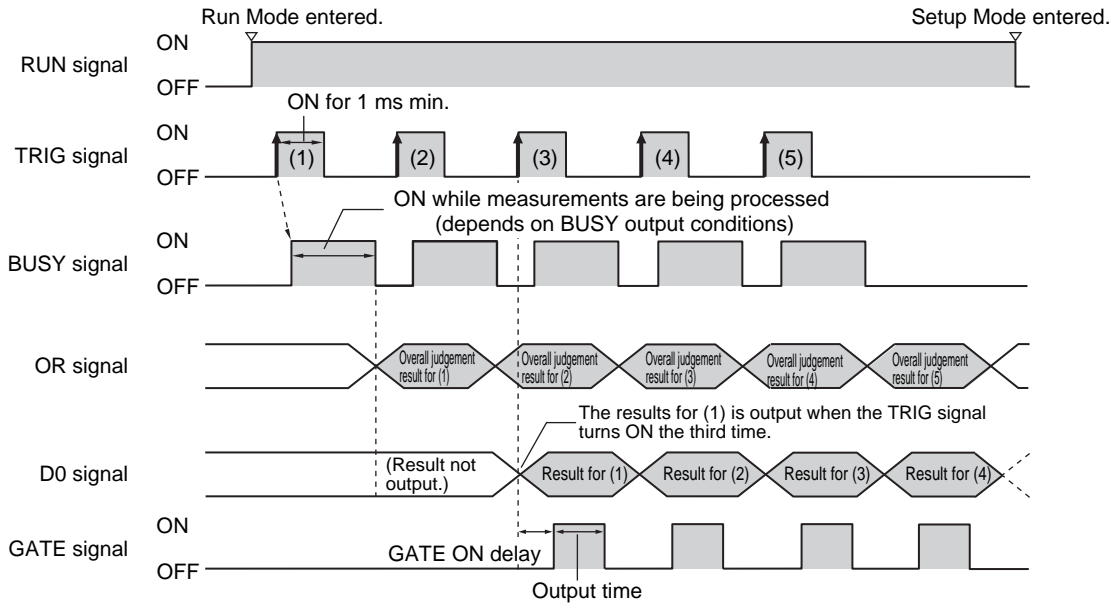

- 1** Repeatedly turn ON the TRIG signal while the BUSY signal is OFF.
- 2** The OR signal is output when the TRIG signal is turned ON.
- 3** When the TRIG signal turns ON for the third time, the measurement result (D0) for the first time that the TRIG signal turned ON is output and the GATE signal is also output at this time.
- 4** When the TRIG signal turns ON for the fourth time, the measurement result (D0) for the second time that the TRIG signal turned ON is output and the GATE signal is also output at this time.
- 5** Each time the TRIG signal turns ON after that, the measurement result (D0) from when the TRIG signal turned ON two times previously is output.

## Changing the Settings of the I/O Signals

### Changing the Settings of the Output Signals

#### ● Adjusting the Judgement Output Timing

You can change the timing of outputting the measurement result with the OR signal (after finalizing the measurement result) according to the needs of the external device.

 Adjusting the Judgement Output Timing: p. 242

#### ● Changing the Judgement Output ON Conditions

You change the ON condition for the OR signal to turn ON the signal when the judgement result is OK or when it is NG.

 Changing the Judgement Output ON Condition: p. 244

#### ● Adjusting the End Timing of the BUSY Signal

You can change the end timing of the BUSY signal.

 Adjusting the Judgement Output Timing: p. 244

#### ● Changing the Output Polarity of the Output Signals

You can change the ON/OFF output polarity of the output signals

#### ▶ **[In/Out] – [I/O setting] – [I/O] – [Output]**

**1 Press [Output polarity] and select the ON/OFF polarity for all output signals.**

Item	Parameter	Description
Output polarity	Positive (default) Negative	You can reverse the ON/OFF conditions of the output signals. For example, when the BUSY signal uses positive polarity, the signal is ON while the Sensor is processing something. If you change the setting to negative polarity, the Sensor will be ready to receive data or signals when the BUSY signal is ON. Applicable Output Signals <ul style="list-style-type: none"><li>• RUN</li><li>• OR</li><li>• BUSY</li><li>• ERROR</li><li>• STGOUT</li><li>• SHTOUT</li><li>• DSA</li><li>• GATE</li><li>• D0 to D15</li><li>• ACK</li></ul>

#### ● Setting the Output Time of the ACK Signal

You can set the output time of the normal execution completion signal for parallel commands.

#### ▶ **[In/Out] – [I/O setting] – [I/O] – [Output] – [ACK signal ON period]**

#### **Important**

The ACK signal is not output for normal completion of continuous measurement commands.

#### ● Changing the Output Timing and Output Time of the STGOUT Signal

You can change the output settings of the STGOUT signal to adjust when and for how long the external lighting is lit.

► [Image] – [Camera setup] – [◀] – [Lighting control]

1 Change the setting for lighting control.

Item	Parameter	Setting	Description
Lighting control	Strobe output delay	0 to 65,535 $\mu$ s (default: 0 $\mu$ s)	Enter the delay time from when the TRIG signal is input until the external lighting is lit.
	Strobe output time	0 to 65,535 $\mu$ s (default: 1,000 $\mu$ s)	Set the pulse width of the output signal (STGOUT) that tells the external lighting when to light.

**Important**

When the strobe polarity is set to [Negative], a delay of about 200 to 300  $\mu$ s occurs from when the TRIG signal is input until the STGOUT signal goes low. When a high-speed shutter is used, set the [Output polarity] parameter to [Positive].

• Timing Chart for Strobe Trigger Output Signal

The STGOUT signal turns ON in sync with the trigger input signal from an external device.

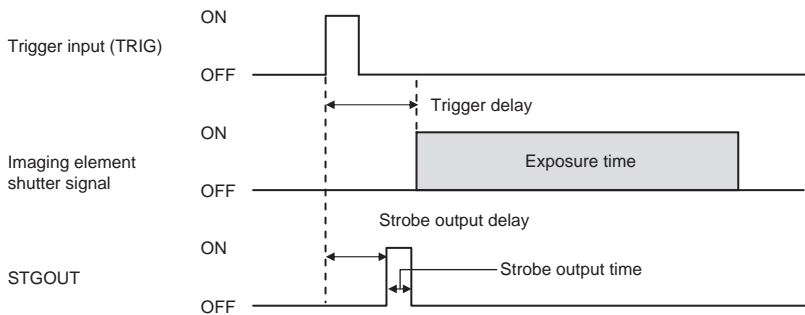

Polarity of all output signals: Positive

## Controlling Operation from an External Device

The following Sensor functions can be controlled with command inputs from an external device without connecting the Touch Finder.

Operation	Description	Reference
Switching the scene	This command changes the scene when the line process changes.	p. 272
Clearing measurement values	This command clears the measurement values. The OR signal and D signals are not cleared.	p. 273
Clearing an error	This command turns the ERROR signal OFF. The ERROR indicator is also turned OFF.	p. 274
Re-registering the model and reference color	This command re-registers the model and reference color.	p. 276
Teaching	This command uses the image that is currently being input to execute teaching for all of the registered items.	p. 277
Clearing the OR and D signals	This command clears the OR signal and D signals.	p. 278
Saving data in the Sensor	This command saves the current settings (scene data and system data) in the Sensor.	p. 280

## Input Format (IN7 to IN0)

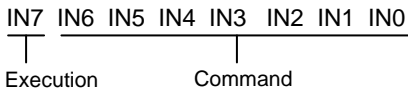

## Changing the Scene

This command changes the scene to shift to a different process.

Parameters

Execution	Command							Input example
IN7	IN6	IN5	IN4	IN3	IN2	IN1	IN0	
1	01		Input the scene number as a binary value.					10100001 (Changes to scene 1.)

Timing Chart

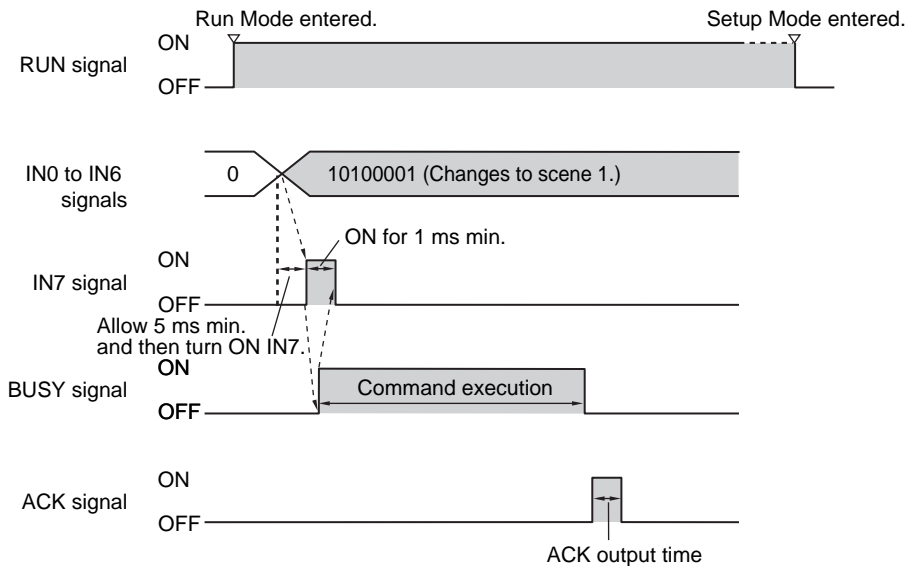

Output Signals

Signal	Function
RUN	This signal is ON while the Sensor is ready to take measurement and it is in Run Mode. It will be OFF in Setup Mode.
BUSY	This signal indicates that the Sensor is currently changing the scene. Do not input the next command while the BUSY signal is ON. The process that is currently being executed and the command that is input will not be executed correctly.
ACK	When the command has been completed normally, this signal is turned ON for the time that is set for the ACK output time.

## Input Signals to Change the Scene

Signal	Function
IN0 to IN4	These signals specify the scene number (0 to 31).
IN5	Turn ON.
IN6	Turn OFF.
IN7	This signal functions as the execution trigger. Set the IN0 to IN6 signals, wait for at least 5 ms, and then turn ON the IN7 signal. The BUSY signal will be ON while the command is being executed.

## Clearing Measurement Values

This command clears the measurement values.

### Parameters

Execution	Command							Input example
IN7	IN6	IN5	IN4	IN3	IN2	IN1	IN0	
1	1000000							11000000

### Timing Chart

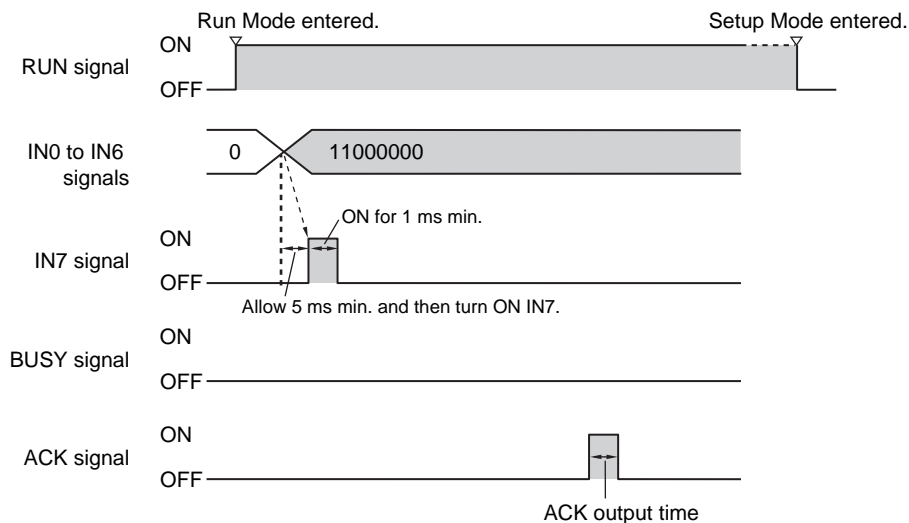

### Output Signals

Signal	Function
RUN	This signal is ON while the Sensor is in Run Mode. It will be OFF in Setup Mode.
BUSY	This signal does not change while clearing measurement values.
ACK	When the command has been completed normally, this signal is turned ON for the time that is set for the ACK output time.

### Input Signals

Signal	Function
IN0 to IN5	Turn OFF.
IN6	Turn ON.
IN7	This signal is the trigger for clearing measurement values. Set the IN0 to IN6 signals, wait for at least 5 ms, and then turn ON the IN7 signal.

## Clearing an Error

This command clears the error output status.

### Parameters

Execution	Command							Input example
IN7	IN6	IN5	IN4	IN3	IN2	IN1	IN0	
1	1000001							11000001

### Timing Chart

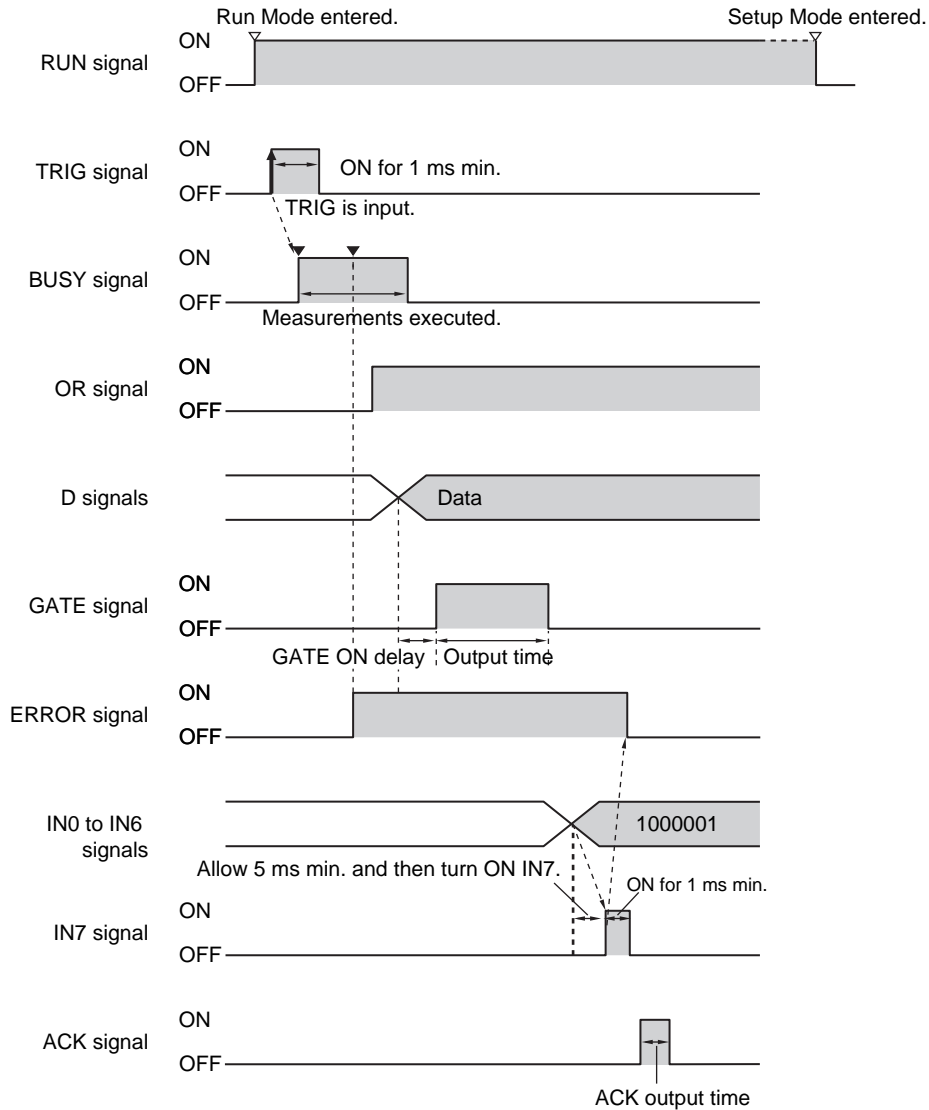



## Output Signals

Signal	Function
RUN	This signal is ON while the Sensor is in Run Mode. It will be OFF in Setup Mode.
BUSY	This signal does not change while clearing errors. However, do not clear an error while the BUSY signal is ON. The command will not be executed correctly.
OR	This signal does not change while clearing errors.
D0 to D15	These signals do not change while clearing errors.
GATE	This signal does not change while clearing errors.
ACK	When the command has been completed normally, this signal is turned ON for the time that is set for the ACK output time.

## Input Signals

Signal	Function
IN0	Turn ON.
IN1 to IN5	Turn OFF.
IN6	Turn ON.
IN7	This signal is the trigger for clearing an error. Set the IN0 to IN6 signals, wait for at least 5 ms, and then turn ON the IN7 signal.

## Re-registering the Model and Reference Color

This command is input from an external devices, such as a PLC, to re-register the models and reference colors for registered inspection items based on the image that was just input.

Inspection items	Re-registered data
Search, Shape Search II, Sensitive Search, Search Position Compensation, and Shape Search Position Compensation	Models
Color Data	Reference color (hue, saturation, and brightness)
Edge Position, Edge Width, Edge Pitch, Area, and Labeling	None

### Parameters

Execution	Command							Input example
IN7	IN6	IN5	IN4	IN3	IN2	IN1	IN0	
1	1001000							11001000

### Timing Chart

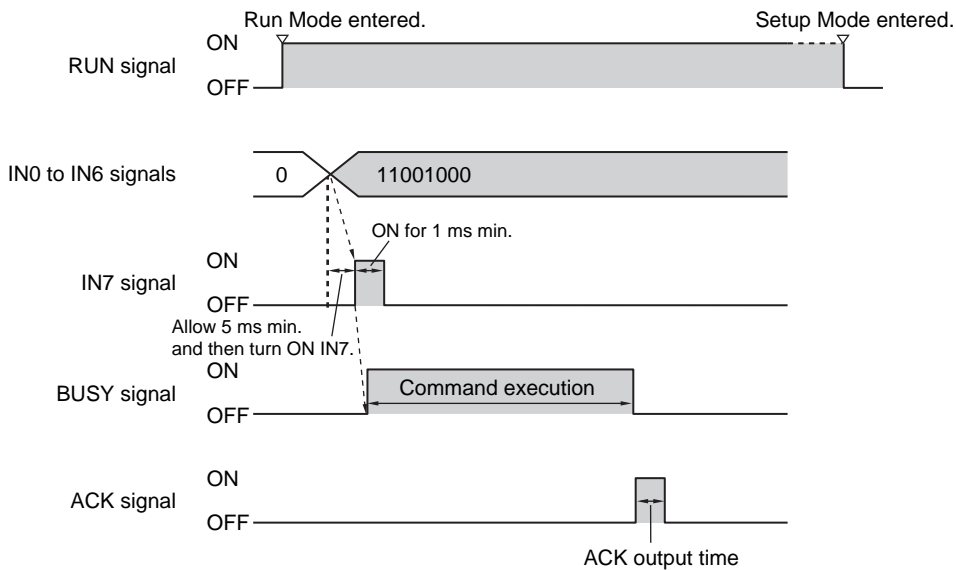

### Output Signals

Signal	Function
RUN	This signal is ON while the Sensor is in Run Mode. It will be OFF in Setup Mode.
BUSY	This signal is ON during re-registration of the model and reference color.
ACK	When the command has been completed normally, this signal is turned ON for the time that is set for the ACK output time.

## Input Signals

Signal	Function
IN0 to IN2	Turn OFF.
IN3	Turn ON.
IN4 and IN5	Turn OFF.
IN6	Turn ON.
IN7	This signal is the trigger for executing re-registration of the model and reference color. Set the IN0 to IN6 signals, wait for at least 5 ms, and then turn ON the IN7 signal. The BUSY signal will be ON while the command is being executed.

## Teaching

This command uses the image that is currently being input to execute teaching for all of the registered inspection items (except for Edge Pitch).

### Parameters

Execution	Command							Input example
IN7	IN6	IN5	IN4	IN3	IN2	IN1	IN0	
1	1001001							11001001

### Timing Chart

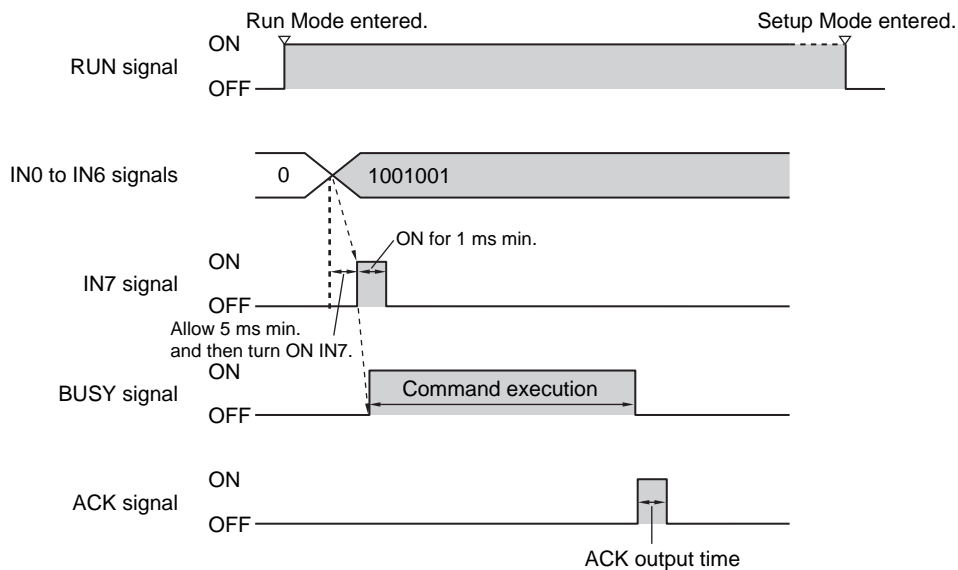

### Output Signals

Signal	Function
RUN	This signal is ON while the Sensor is in Run Mode. It will be OFF in Setup Mode.
BUSY	This signal is ON while teaching is being executed.
ACK	When the command has been completed normally, this signal is turned ON for the time that is set for the ACK output time.

## Input Signals

Signal	Function
IN0	Turn ON.
IN1 and IN2	Turn OFF.
IN3	Turn ON.
IN4 and IN5	Turn OFF.
IN6	Turn ON.
IN7	This signal is the trigger for executing teaching. Set the IN0 to IN6 signals, wait for at least 5 ms, and then turn ON the IN7 signal. The BUSY signal will be ON while the command is being executed.

## Clearing the OR and D Signals

This command clears the OR signal and D signals.

### Parameters

Execution	Command							Input example
IN7	IN6	IN5	IN4	IN3	IN2	IN1	IN0	
1	1000010							11000010

### Timing Chart

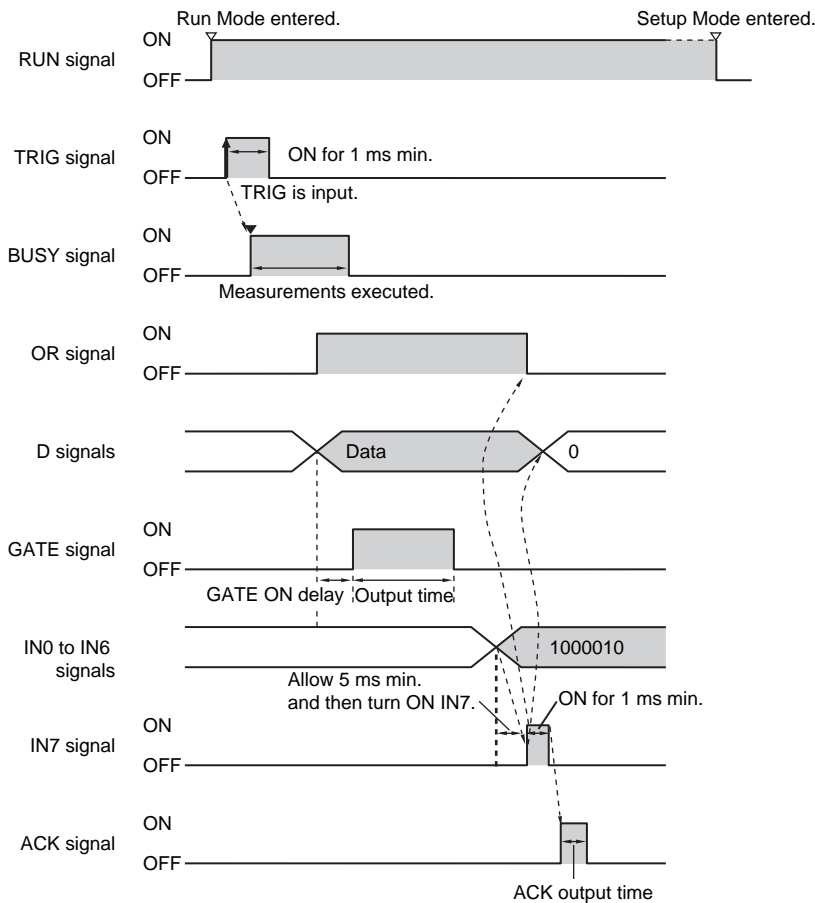

## Output Signals

Signal	Function
RUN	This signal is ON while the Sensor is in Run Mode. It will be OFF in Setup Mode.
BUSY	This signal does not change while clearing the OR and D signals. However, do not clear the OR and D signals while the BUSY signal is ON. The command will not be executed correctly.
OR	If this signal was ON, it will be turned OFF.
D0 to D15	If these signals were ON, they will be turned OFF.
GATE	This signal does not change while clearing the OR and D signals. However, do not clear the OR and D signals while the GATE signal is ON. The command will not be executed correctly. Also, the D and GATE outputs may not function correctly.
ACK	When the command has been completed normally, this signal is turned ON for the time that is set for the ACK output time.

## Input Signals

Signal	Function
IN0	Turn OFF.
IN1	Turn ON.
IN2 to IN5	Turn OFF.
IN6	Turn ON.
IN7	This signal is the trigger for clearing the OR and D signals. Set the IN0 to IN6 signals, wait for at least 5 ms, and then turn ON the IN7 signal.

## Saving Data in the Sensor

This command saves the current settings (scene data and system data) in the Sensor.

### Parameters

Execution	Command							Input example
IN7	IN6	IN5	IN4	IN3	IN2	IN1	IN0	
1	101000							1101000

### Timing Chart

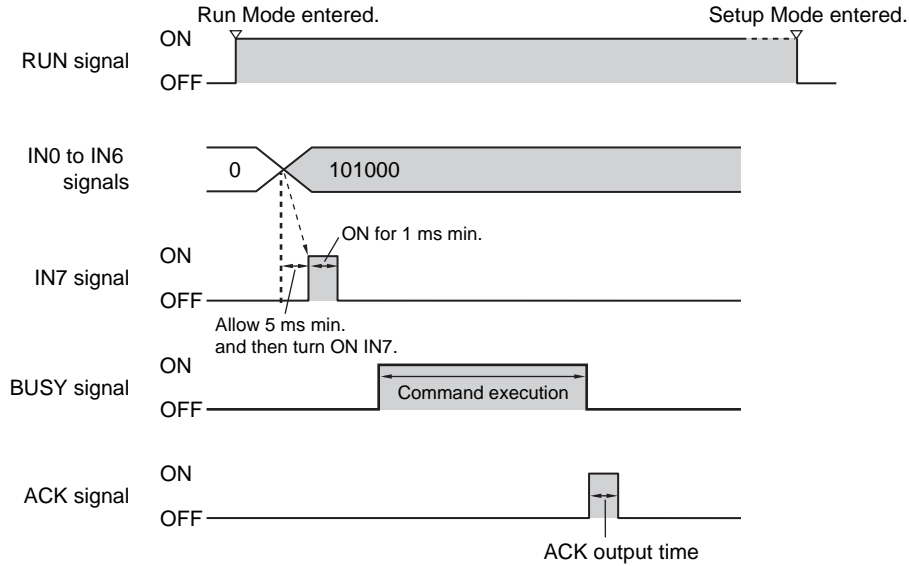

### Output Signals

Signal	Function
RUN	This signal is ON while the Sensor is in Run Mode. It will be OFF in Setup Mode.
BUSY	This signal will be ON while data is being saved in the Sensor.
ACK	When the command has been completed normally, this signal is turned ON for the time that is set for the ACK output time.

### Input Signals

Signal	Function
IN1 to IN3	Turn OFF.
IN4	Turn ON.
IN5	Turn OFF.
IN6	Turn ON.
IN7	This signal is the trigger for saving data in the Sensor. Set the IN0 to IN6 signals, wait for at least 5 ms, and then turn ON the IN7 signal.

# Connecting through Ethernet

---

9-1 Introduction .....	282
9-2 Outputting Data and Controlling Operation through EtherNet/IP ..	283
9-3 PLC Link Connections .....	324
9-4 Controlling Operation and Outputting Data with TCP No-protocol Communications .....	350
9-5 Controlling Operation and Outputting Data with FINS/TCP No-protocol Commands .....	376

# 9-1 Introduction

With the FQ2, you can use any of the following protocols to transfer data through Ethernet.

Protocol	Transfer method	Reference
TCP no-protocol commands	Commands are sent from the PLC to control the Sensor. Received data is stored in the buffer memory of the specified port.	p. 350
FINS/TCP no-protocol commands		p. 376
PLC Link <sup>*1</sup>	You can control the Sensor and obtain measurement results simply by manipulating bits and words in the memory of the PLC. When you turn ON the Command Execution Bit at a specific memory address in the PLC, a command in a specified memory area (e.g., the DM Area or CIO Area) in the PLC is read and sent to the Sensor. The results of executing the command are written to specified words in the memory of the PLC. These words are specified in advance. You can use this method when the external device is a PLC.	p. 324
EtherNet/IP <sup>*2</sup> (tag data links)		p. 283

\*1 A PLC Link uses three link areas to perform communications: the Command Area, Response Area, and Data Output Area.

A PLC Link is not the same as the Serial PLC Link protocol used to connect PLCs together with serial communications.

\*2 The signal timing is equivalent to parallel I/O, i.e., command execution and data output are performed independently.

## Note

You can also use the parallel interface for other controls, such as controlling measurements, changing scenes, clearing errors, and clearing measurement values.

If a Parallel Interface Sensor Data Unit is mounted, you can output the judgement results of judgement conditions, the measurement values from measurement items, and the results of expressions through the parallel interface.



8-2 Controlling Operation and Outputting Data with a Parallel Interface Sensor Data Unit: p. 256

If an RS-232C Sensor Data Unit is mounted, you can transfer data through an RS-232C connection using TCP no-protocol commands.



10. Connecting with RS-232C: p. 391



## 9-2 Outputting Data and Controlling Operation through EtherNet/IP

### Introduction to EtherNet/IP

EtherNet/IP is an industrial multi-vendor network that uses Ethernet.

The EtherNet/IP specifications are open standards managed by the ODVA (Open DeviceNet Vendor Association). EtherNet/IP is used by a wide range of industrial devices.

Because EtherNet/IP uses standard Ethernet technology, various general-purpose Ethernet devices can be used in the network.

EtherNet/IP has mainly the following features.

- High-speed, High-capacity Data Exchange through Tag Data Links

The EtherNet/IP protocol supports implicit communications, which allows cyclic communications called tag data links with EtherNet/IP devices.

- Tag Data Links at Specified Communications Cycle for Each Application Regardless of the Number of Nodes

Tag data links (cyclic communications) operate at the cyclic period that is specified for each application, regardless of the number of nodes. Data is exchanged over the network at the refresh cycle that is set for each connection. The communications refresh cycle will not increase even if the number of nodes is increased, i.e., the concurrency of the connection's data is maintained.

Because the refresh cycle can be set for each connection, each application can communicate at its ideal refresh cycle. For example, interprocess interlocks can be transferred at high speed, while the production commands and the status monitor information are transferred at low speed.

#### Important

On a network to which many devices are connected, performance may drop (e.g., responses may be delayed or packets lost) or communications errors may occur when there is temporarily high traffic on the network. Test the operation under actual conditions before you start actual operation of the system.

## Data Exchange with EtherNet/IP

Data is exchanged cyclically between Ethernet devices on the EtherNet/IP network using tag data links as shown below.

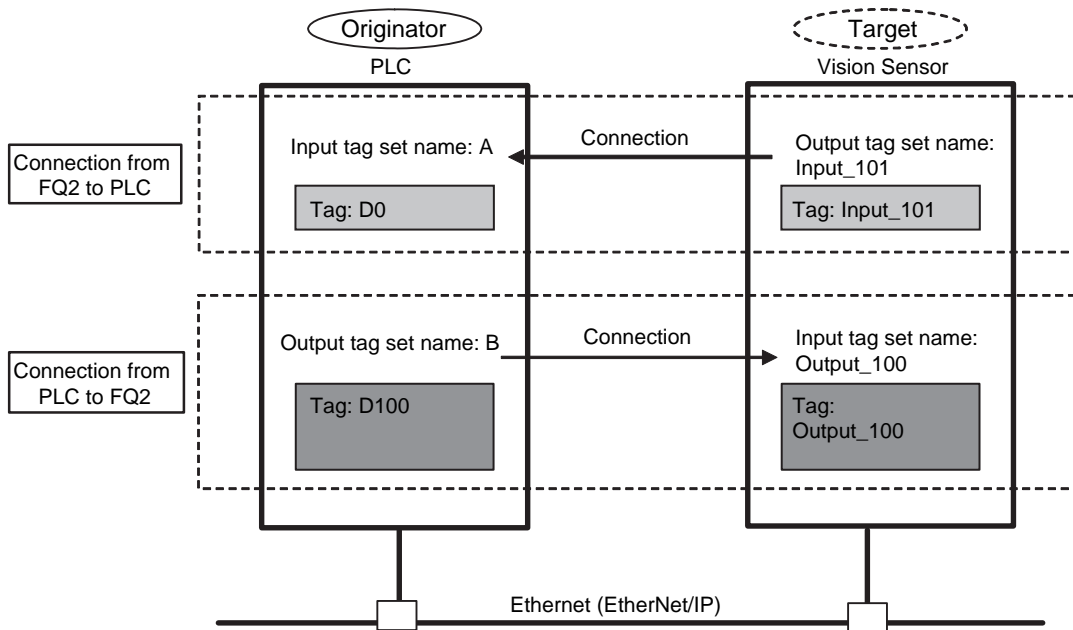

### ● Data Exchange Method

To exchange data, a connection is opened between two EtherNet/IP devices.

One of the nodes requests the connection to open a connection with a remote node.

The node that requests the connection is called the originator, and the node that receives the request is called the target.

### ● Data Exchange Memory Locations

The memory locations that are used to exchange data across a connection are specified as tags.

You can specify memory addresses or variables for tags.

A group of tags consists of an output tag set and an input tag set.

## FQ2 Communications for EtherNet/IP Connections

You can use EtherNet/IP tag data links to communicate between the PLC and the Vision Sensor to perform control via command/response communications or to output data after measurements.

The FQ2 complies with EtherNet/IP conformance test version A8.

To connect to OMRON Controllers and communicate through EtherNet/IP, you use the Network Configurator to set up tag data links (i.e., tags, tag sets, and connection settings).

Refer to the following manuals for details on the tag data link settings that are made with the Network Configurator.

- NJ-series CPU Unit Built-in EtherNet/IP Port User's Manual (Cat. No. W506)
- CS/CJ-series EtherNet/IP Units Operation Manual (Cat. No. W465)
- CJ-series EtherNet/IP Units Operation Manual for NJ-series CPU Unit (Cat. No. W495)

### Types of Communications

#### ● Command/Response Communications

With EtherNet/IP communications, cyclic tag data link communications are performed with the connections that are set between the PLC and Vision Sensor.

Command/response control signals are handled by storing control commands from the PLC to the Vision Sensor and responses from the Vision Sensor to the PLC in the I/O memory of the PLC.

This allows you to control the operation of the Vision Sensor (e.g., perform continuous measurements or change the scene) without using special communications instructions.

#### • Input Connection to Sensor (PLC to Vision Sensor)

The commands that are stored in the I/O memory of the PLC are sent to the Vision Sensor.

#### • Output Connection to PLC (Vision Sensor to PLC)

Responses from the Vision Sensor to the control commands are stored in the PLC I/O memory addresses or variables that are specified for the response area.

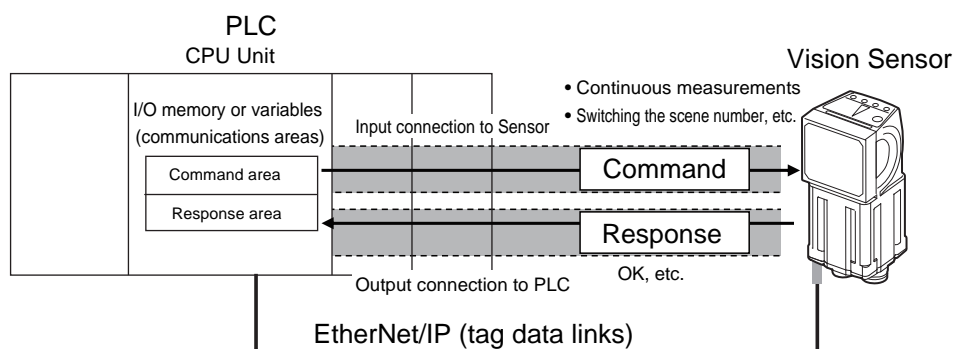

To send a control command, you write a control command to the command area (i.e., a variable or I/O memory address in the PLC) that is specified for the output tag, and then turn ON the Command Execution (EXE) Bit. As a result, the control command is sent through the input connection from the PLC to the Vision Sensor.

A control command does not need to be sent to execute measurements for the TRIG bit.

The measurement is executed simply by turning ON the TRIG bit.

The Vision Sensor executes the control command and sends a response back to the PLC through the output connection from the Vision Sensor to the PLC.

The PLC stores the response in the response area (i.e., I/O memory addresses or variable) that is specified for the input tag in the PLC.

### ● Data Output after Measurements

Immediately after a single measurement or continuous measurements, the Vision Sensor will automatically output the data for the measurements that are specified for output in advance to the I/O memory addresses or variable that is specified for the input tag in the PLC.

This enables you to easily transfer the measurement results data for inspection items to the PLC.

When handshaking is enabled, the data is output from the Vision Sensor only when the condition to receive that data are met at the PLC.

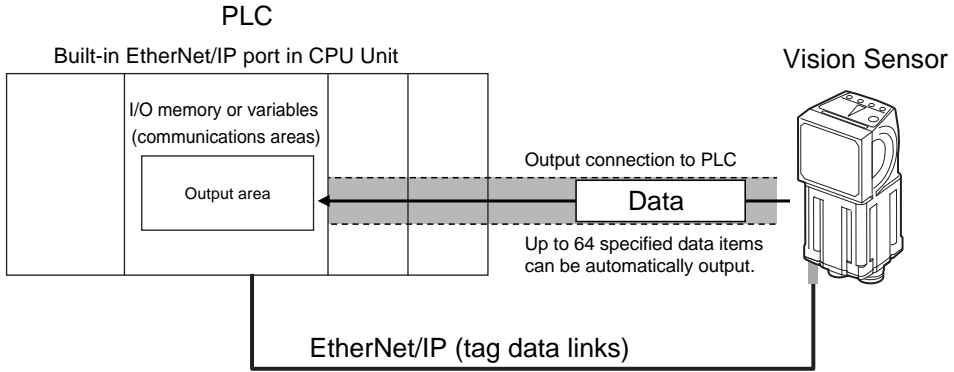

To output data, you must specify in advance the data to output (up to 64 items) after the measurements are executed.

You must also specify in advance the output area (i.e., I/O memory addresses or variable) for the input tag to store the data in the PLC.

After a single measurement or continuous measurements, the data is automatically stored in the output area (i.e., I/O memory addresses or variable) that is specified for the input tag in the PLC via the connection from the Vision Sensor to the PLC.

## Types of Communications Areas

For EtherNet/IP communications, the following three communications areas are used in the PLC to perform communications.

### Areas Used for the Different Control Methods

Command/response communications	(1) Command area	This is the area to which you write control commands for the Vision Sensor to execute.
	(2) Response area	This is the area to which the Vision Sensor writes the results of control commands executed from the command area.
Data output after measurements	(3) Output area	This is the area to which the Vision Sensor writes output data for measurements after an inspection is performed.

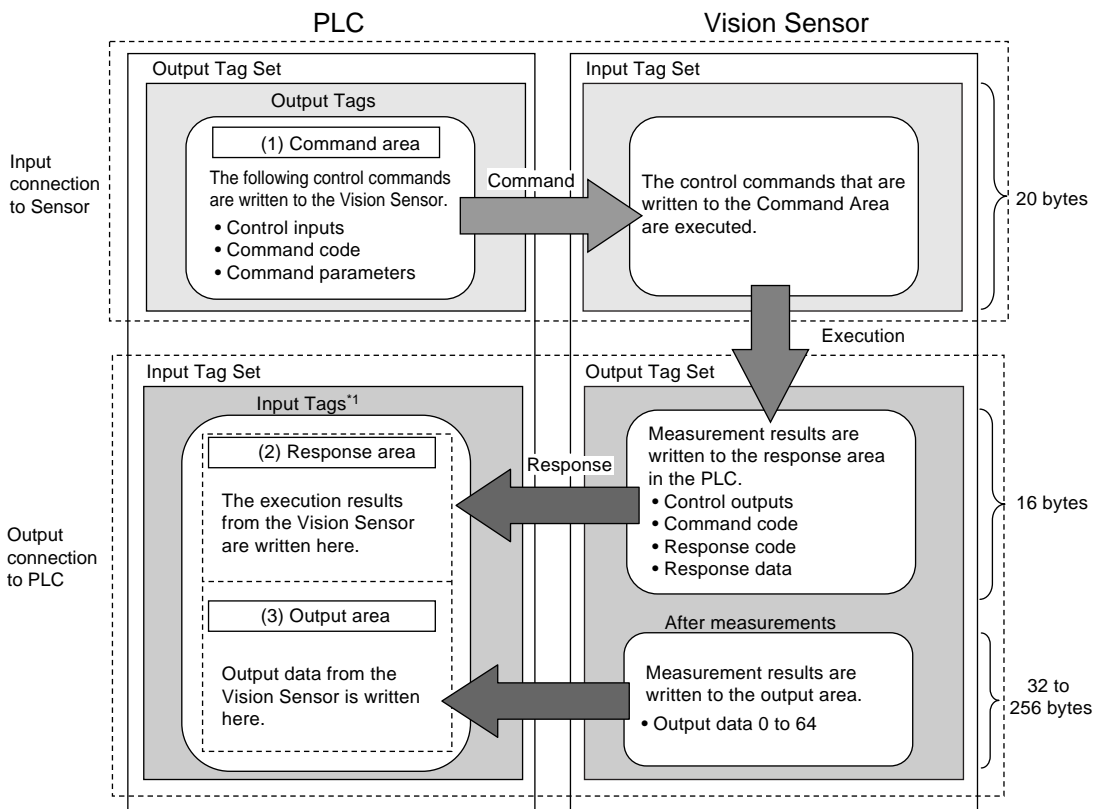

\*1 The response area (2) and output area (3) are assigned to continuous memory addresses or to a variable.

## Connectable Controller Models

Series	CPU Unit	Interface	
		Built-in port in CPU Unit	EtherNet/IP Unit
SYSMAC NJ	NJ501 or NJ301	Compatible	CJ1W-EIP21
SYSMAC CJ2	CJ2H or CJ2M	Compatible (model with built-in port only)	CJ1W-EIP21
SYSMAC CJ1	CJ1H or CJ1G	---	CJ1W-EIP21
	CJ1M	---	CJ1W-EIP21
SYSMAC CS	CS1H, CS1D, or CS1G	---	CS1W-EIP21

# Setting Up EtherNet/IP Communications

## Setting Network Settings in the Sensor

This section describes how to set the IP address and other network settings in the Vision Sensor. Refer to the following section for details.

 2-5 Setting Up Ethernet: p. 53

### Important

To use EtherNet/IP communications, do not automatically assign an IP address to the Vision Sensor. Set a specific IP address and do not change it.

## Initial Settings for EtherNet/IP Communications

▶  (Setup Mode) – [Sensor settings] – [Data output] – [Link data output]

- 1 Press [Communication type].
- 2 Press [EtherNet/IP].
- 3 Set the EtherNet/IP communications parameters as described in the following table.





[Handshake setting] Set to [Yes]



Link data output	
Communication type	EtherNet/IP
Handshake setting	Yes
Output data size	32 bytes
Communication cycle	10
Timeout	1000

[Handshake setting] Set to [No]

Link data output	
Communication type	EtherNet/IP
Handshake setting	No
Output data size	32 bytes
Communication cycle	10
Data output period	400
GATE signal ON period	20

Parameter	Description	Setting range
Handshake setting	<p>Set whether to synchronize with the PLC when data is output.</p> <p>No: Measurement results are output without synchronizing with the PLC.</p> <p> I Data Output after Measurements When Handshaking Is Disabled: p. 321</p> <p>Yes: Measurement results are output while synchronizing with the PLC.</p> <p> I Data Output after Measurements When Handshaking Is Enabled: p. 321</p>	<ul style="list-style-type: none"> <li>• Yes</li> <li>• No</li> </ul> (default: Yes)
Output data size	<p>Set the data size to output from the output area. Any changes in the setting are applied when the Sensor is restarted.</p> <p><b>Note</b></p> <p>If the total size of the data that is specified as output data exceeds the size that is set here, all of the data will not be output at the same time, but will be separated over more than one cycle.</p> <p> I Output Data Size and Number of Output Data Upper Value Setting: p. 298</p> <p><b>Important</b></p> <p>Set the input connection (input tag set) to 16 bytes greater than the size that you set for this parameter.</p>	32 bytes, 64 bytes, 128 bytes, or 256 bytes (default: 32 bytes)
Refreshing task period	<p>Set the communications cycle for cyclic tag data link communications for the Vision Sensor. Set the same value as you set for the requested packet interval (RPI) on the Network Configurator.</p> <p><b>Important</b></p> <ul style="list-style-type: none"> <li>• Set this parameter to the same value as you set for the requested packet interval (RPI) in the PLC.</li> <li>• This parameter is necessary for the FQ2 to synchronize with the communications cycles of the cyclic tag data link communications that are set for tag connections on the Network Configurator and in the PLC.</li> <li>• If the value in the FQ2 is longer than the value in the PLC, cyclic data exchange will not be performed according to the expected communications cycle.</li> <li>• The smaller the setting of this parameter is, the more the measurement processing time will be affected. For the lowest setting of 4 ms, the processing time will increase by approximately 5% to 10%.</li> </ul>	4 to 10,000 ms (default:10 ms)



Parameter	Description	Setting range
Timeout	<p>This parameter is displayed and can be set only when [Handshake setting] is set to [Yes]. A timeout error will occur if there is no response from the PLC within the time that is set.</p> <ul style="list-style-type: none"> <li>• From when measurements are completed until the DSA Bit turns ON</li> <li>• From when the GATE flag turns ON until the DSA Bit turns OFF</li> <li>• From when the GATE flag turns OFF until the DSA Bit turns ON</li> </ul>	0.1 to 120.0 s (default: 10 s)
Data output period	<p>This parameter is displayed and can be set only when [Handshake setting] is set to [No]. Set the period for outputting measurement results.</p> <p><b>Important</b></p> <p>Set a value that is longer than the GATE ON output time and shorter than the measurement interval of the Sensor.</p>	2 to 5,000 ms (default: 40 ms)
GATE signal ON period	<p>This parameter is displayed and can be set only when [Handshake setting] is set to [No]. Set the time to turn ON the GATE signal. Set the time that is required for the PLC to read the measurement results.</p> <p><b>Important</b></p> <p>Set the cycle time of the PLC so that it is longer than the packet interval (RPI).</p>	1.0 to 1,000.0 ms (default: 20.0 ms)

## Tag Data Link Setting Methods

This section describes how to set data links for EtherNet/IP.

The communications areas in the PLC for which data links are created to the Sensor are specified as tags and tag sets, and the connections are set for tag data link communications.

Tags, tag sets, and connections are set from the Network Configurator.

Refer to the following manuals for details on the tag data link settings that are made with the Network Configurator.

- NJ-series CPU Unit Built-in EtherNet/IP Port User's Manual (Cat. No. W506)
- CS/CJ-series EtherNet/IP Units Operation Manual (Cat. No. W465)
- CJ-series EtherNet/IP Units Operation Manual for NJ-series CPU Unit (Cat. No. W495)

### Important

- To connect the FQ2 to an NJ/CJ-series CPU Unit, install the EDS file that defines the connection information for the FQ2 in the Network Configurator. Download the EDS file from the OMRON website.
- After tag data links are set, the Vision Sensor will automatically be restarted to enable the settings.

## Tags, Tag Sets, and Connection Settings

The communications areas in the PLC are set as tag data link connections as shown in the following table.

- Tag and Tag Set Settings in the PLC

Parameter	Settings	
	Command area	Response area and output area
Type of tags and tag set	Output tag set	Input tag set
Tag and tag set names	I/O memory addresses or variable names	I/O memory addresses or variable names <sup>*1</sup>
Data size	20 bytes	48 to 272 bytes (total size of response area and output area)

<sup>\*1</sup> Specify the I/O memory address of the first word in the response area. The output area is assigned immediately after the response area. If you specify a variable name, the variable is assigned for both the response area and output area. Refer to Accessing Communications Areas Using Variables with NJ-series Controllers on p. 304 for information on how to access the signals in the communications areas from the user program when variables are assigned.

● Settings in the FQ2 (Device Parameter Settings)

- 1 Right-click the FQ2 in the network on the Network Configurator and select [Parameter] – [Edit].
- 2 The Edit Device Parameters Dialog Box will be displayed. Make the required settings.

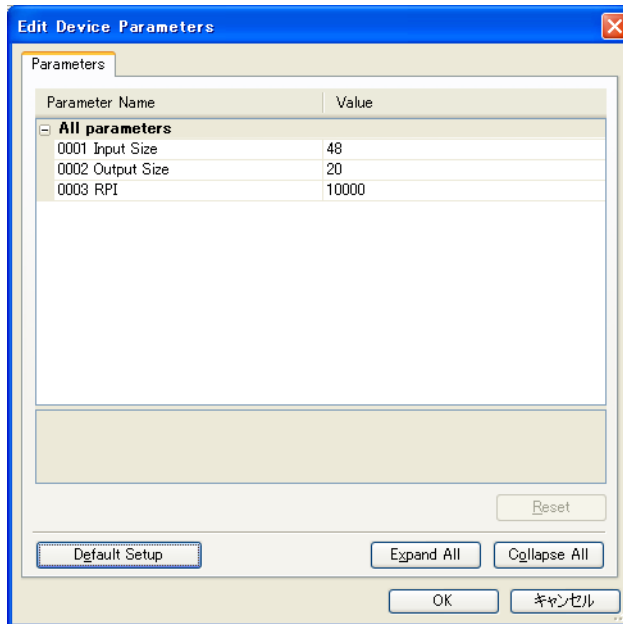

Parameter name	Value	Setting range
001 Input Size <sup>*1</sup>	The total size of response area and output area	48 to 272
002 Output Size <sup>*2</sup>	The data size of command area	20
003 RPI <sup>*3</sup>	The requested packet interval	10000

\*1 Although the data size can be set as high as 502 bytes, with the current version set one of the following as the total data size for the output area (data output size) and the response area (16 bytes).

- 48 bytes (default)
- 80 bytes
- 144 bytes
- 272 bytes

\*2 Although the data size can be set as high as 502 bytes, with the current version use the default setting of 20 bytes.

\*3 The packet interval (RPI) is set in the connection settings between the PLC and the Sensor. No setting is required here.

● Connection Settings

Parameter		Setting
Originator device (PLC)	Input tag set	<i>PLC_tag_set_name</i> -[**Byte] **: This is the total size of the response area and output area that you set.
	Connection type	Any (default: multi-cast connection) <sup>*1</sup>
	Output tag set	<i>PLC_tag_set_name</i> -[20Byte]
Target device (Vision Sensor)	Output tag set	Input_101-[**Byte] **: This is the total size of the response area and output area that you set.
	Input tag set	Output_100-[20Byte]
Packet interval (RPI)		Any (default: 20.0) <sup>*2</sup>

\*1 If multi-cast connections are used, however, use an Ethernet switch that has multi-cast filtering, unless the tag set is received by all nodes in the network.

\*2 Set the same value as you set for the refreshing task period in the EtherNet/IP communications settings.

**Important**

- If I/O memory addresses are specified for the communications areas, the information in the communications areas will be cleared when the operating mode of the PLC changes unless addresses in the CIO Area, which are maintained, are specified.
- The following assembly object is required to specify instances when the EDS file is not used.

Assembly Object Settings

Parameter name	Setting	Remarks
Instance ID	100	Output connection
	101	Input connection

## Setting the Data To Output Automatically after Measurements

You can specify the measurement data to output automatically to the PLC after measurements.

### Data That Can Be Output

You can output up to 64 data items (256 bytes) with the output data (data 0 to data 31).

The measurement data from inspection items that can be output and the calculation results from the expression settings can be output.

For data that can be output, refer to the *Measurement Data That Can Be Used for External Outputs and Calculations* for each inspection item.

### Assigning Inspection Results to Output Data

You can individually assign the parameters of the inspection items to output data (data 0 to data 31).

The following procedure shows how to assign the measured position X of [0. Search] to data 0 for a binary output.

#### ► [In/Out] – [I/O setting] – [Output data setting] – [Link data output] – [Output data set]

- 1 Press [0. Data 0].
- 2 Press [Data setting].
- 3 Press [I0. Search].
- 4 Press [Position X X].

- 5 If the inspection item allows multi-point output, press the number ([0] to [30]) of the inspection result for which to output the data from the list of inspection results.

To register something to data 1 and higher, repeat this process. The settings will be enabled after you restart the Sensor.

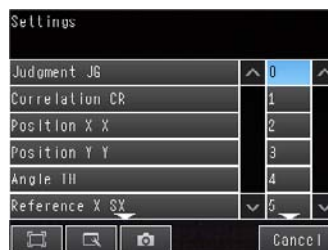
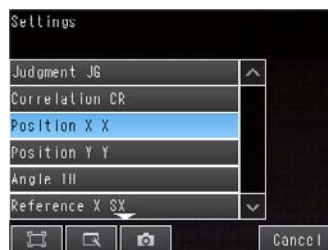

## Assigning More Than One Inspection Result to the Same Output Data

You can assign more than one inspection result to the same data output to output all of the assigned results. This is possible for the following inspection results.

- Parameters for the same inspection item: You can assign up to five inspection results.
- Inspection results that support multi-point output: You can assign inspection results within the specified range (0 to 31).

The following procedure shows how to assign more than one inspection result to data 0.

### ► [In/Out] – [I/O setting] – [Output data setting] – [Link data output] – [Output data set]

- 1 Press [0. Data 0].
- 2 Press [Multi-data setting].
- 3 Set the following items on the display to set expressions.



Item	Description
Expression	Register the expression to use to output multiple data. Examples: LPR (0, 3, I0.X, I0.Y) LPC (0, I0.C, I0.X, I0.Y)
Const.	Used to insert numbers and symbols into the expression.
Data	Used to select the inspection items for which to output data and insert the parameters to output into the expression. Example: Selecting Parameters for the Search Item at Inspection Item 0 Inspection item: I0. Search Judgement result: Judgement JG, Correlation: Corre. CR
Math.	Either of the following two functions can be inserted. <ul style="list-style-type: none"> <li>• LPR function (order of the measurement data) The measurement data is output in order. Format: LPR(start_number,number_of_data,data_1, data_2,...data_5) You can omit data 2 to data 5.</li> <li>• LPC function (order of the detection points) Data is output for each detected measurement point. Format: LPC(start_number,number_of_data,data_1, data_2,...data_5) You can omit data 2 to data 5.</li> </ul>

To register something to data 1 and higher, repeat this process.

The settings will be enabled after you restart the Sensor.

● Expression Setting Example

This example registers an expression to output the following inspection results for data 0.

Inspection item: 0 Search

Parameters to output: Position X, Position Y, Reference SX, and Reference SY

Multi-point output setting: Multi-point output Check Box selected, Count = 4

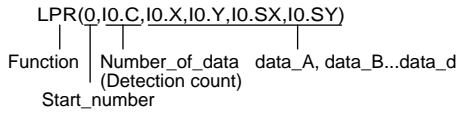

Output Results

The expression that is registered for data 0 assigns the data for 16 items (64 bytes) in the output area as shown below.

Output area data	Assigned data
Output data 0 (4 bytes)	I0.X[0] (Position X 1st point)
Output data 1 (4 bytes)	I0.Y[0] (Position Y 1st point)
Output data 2 (4 bytes)	I0.SX[0] (Reference SX 1st point)
Output data 3 (4 bytes)	I0.SY[0] (Reference SY 1st point)
Output data 4 (4 bytes)	I0.X[1] (Position X 2nd point)
Output data 5 (4 bytes)	I0.Y[1] (Position Y 2nd point)
Output data 6 (4 bytes)	I0.SX[1] (Reference SX 2nd point)
Output data 7 (4 bytes)	I0.SY[1] (Reference SY 2nd point)
Output data 8 (4 bytes)	I0.X[2] (Position X 3rd point)
Output data 9 (4 bytes)	I0.Y[2] (Position Y 3rd point)
Output data 10 (4 bytes)	I0.SX[2] (Reference SX 3rd point)
Output data 11 (4 bytes)	I0.SY[2] (Reference SY 3rd point)
Output data 12 (4 bytes)	I0.X[3] (Position X 4th point)
Output data 13 (4 bytes)	I0.Y[3] (Position Y 4th point)
Output data 14 (4 bytes)	I0.SX[3] (Reference SX 4th point)
Output data 15 (4 bytes)	I0.SY[3] (Reference SY 4th point)

**Note**

The inspection results will be output according to the sorting method that is set for multi-point output for the inspection item.

● Output Data Size and Number of Output Data Upper Value Setting

When more than one inspection result is output, the size of the data that is output for the data output settings could exceed the limit that is set in the [Max output data] (number of output data upper value) parameter setting.

If that occurs, increase the set value of the output data size setting or adjust the output data settings so that data output size is not exceeded.

If the size of data that is output does exceed the set value of the [Max output data] (number of output data upper value) parameter setting, the remaining data will be discarded.

Example

Output data size: 328 bytes

Output data size setting: 256 bytes

Data Output Settings

Output data	Setting	
Data 0	I0.X[0]	Inspection item 0: Position X for Search
Data 1	I0.Y[0]	Inspection item 0: Position Y for Search
Data 2	LPC (0,30,I1.X,I1.Y)	Inspection item 1: Position X 1st point for Shape Search II  Inspection item 1: Position X 30th point for Shape Search II Inspection item 1: Position Y 1st point for Shape Search II  Inspection item 1: Position Y 30th point for Shape Search II
Data 3	LPR (0,10,I2.X,I2.Y)	Inspection item 2: Position X 1st point for Shape Search II Inspection item 2: Position Y 1st point for Shape Search II  Inspection item 2: Position X 10th point for Shape Search II Inspection item 2: Position Y 10th point for Shape Search II

} 328 bytes



The output data that is assigned is output to the output area as shown below.

Output data that exceeds the size (256 bytes) that is set for the output data size parameter is separated over more than one cycle.

Offset from first address in output area	Output data	Assigned output data	
+0	Output data 0 (4 bytes)	Inspection item 0: Position X for Search	256 bytes (Data that is output the first cycle.)
+1			
+2	Output data 1 (4 bytes)	Inspection item 0: Position Y for Search	
+3			
+4	Output data 2 (4 bytes)	Inspection item 1: Position X 1st point for Shape Search II	
+5			
⋮	⋮	⋮	
+62	Output data 31 (4 bytes)	Inspection item 1: Position X 30th point for Shape Search II	
+63			
+64	Output data 32 (4 bytes)	Inspection item 1: Position Y 1st point for Shape Search II	
+65			
⋮	⋮	⋮	
+122	Output data 61 (4 bytes)	Inspection item 1: Position Y 30th point for Shape Search II	
+123			
+124	Output data 62 (4 bytes)	Inspection item 2: Position X 1st point for Shape Search II	
+125			
+126	Output data 63 (4 bytes)	Inspection item 2: Position Y 1st point for Shape Search II	
+127			
+0	Output data 0 (4 bytes)	Inspection item 2: Position X 2nd point for Shape Search II	72 bytes (Data that is output the second cycle.*1)
+1			
⋮	⋮	⋮	
+12	Output data 6 (4 bytes)	Inspection item 2: Position X 10th point for Shape Search II	
+13			
+14	Output data 7 (4 bytes)	Inspection item 2: Position Y 10th point for Shape Search II	
+15			

\*1 If the size of the specified output data exceeds the set value of the output data size setting, the data is output separately as shown below.

Output data size setting: 256 bytes

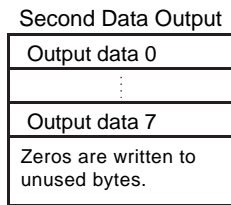
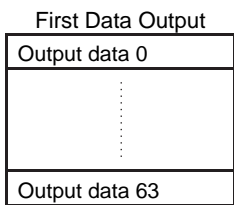

The previous data will be overwritten. Adjust the timing with handshaking to get the data.

## Setting the Output Format

### ► [In/Out] – [I/O setting] – [Output data setting] – [Link data output]

- 1 Press [Output format].
- 2 Press [Output form].
- 3 Set either a floating point decimal or a fixed decimal for the output form.

Item	Description	Setting range
Output form	Set the output form for numerical data.	Floating point or fixed point (default: Floating point)

## Memory Assignments and Commands

### Memory Assignments

This section describes the assignments of the command area for the input connection to the Sensor and the response and output areas for the output connection to the PLC.

#### ● Input Connection to Sensor (PLC Originator to Vision Sensor Target)

##### • Command Area

	Bits																Contents
	15	14	13	12	11	10	9	8	7	6	5	4	3	2	1	0	
+0	ERCLR	Resv	Resv	Resv	Resv	Resv	Resv	Resv	Resv	Resv	Resv	Resv	Resv	Resv	TRIG	EXE	Control signals (32 bits)
+1	Resv	Resv	Resv	Resv	Resv	Resv	Resv	Resv	Resv	Resv	Resv	Resv	Resv	Resv	Resv	DSA	
+2	Command code																Command code (32 bits)
+3																	
+4	Parameter 1																Parameter 1 (32 bits)
+5																	
+6	Parameter 2																Parameter 2 (32 bits)
+7																	
+8	Parameter 3																Parameter 3 (32 bits)
+9																	
Signal	Signal name		Function													Application method	
EXE	Control Command Execution Bit		Turn ON this signal from the PLC to send a control command for the Vision Sensor to execute. Set the control command code and parameters before you turn ON this signal.  Turn OFF the EXE signal from the PLC when the Control Command Completed (FLG) signal from the Vision Sensor turns ON.													Command/response communications	

Signal	Signal name	Function	Application method
TRIG	Execute Measurement	Turn ON this signal from the PLC to send a command to execute a measurement.	Command/ response communications
		This signal returns to OFF when the Command Execution Active (BUSY) signal goes ON.	
DSA	Data Output Request Bit * This bit can be used only when handshaking is enabled.	Turn ON this signal from the PLC to request data output. When this signal turns ON, the Vision Sensor outputs data.	Data output after measurements
		Turn OFF the DSA signal from the PLC when the Data Output Completed (GATE) signal from the Vision Sensor turns ON.	
ERCLR	Clear Error	Turn ON this signal to turn OFF the error (ERR) signal from the Vision Sensor.	Command/ response communications
		Turn OFF this signal from the PLC when the error (ERR) signal goes OFF.	
Command code	Command code	This I/O port stores the command code.	Command/ response communications
Parameters 1 to 3	Command parameters	These I/O ports store the command parameters.	

● Output Connection to PLC (Vision Sensor Originator to PLC Target)

• Response Area

	Bits																Contents
	15	14	13	12	11	10	9	8	7	6	5	4	3	2	1	0	
+0	ERR	Resv	Resv	Resv	Resv	Resv	Resv	Resv	Resv	Resv	Resv	RUN	OR	READY	BUSY	FLG	Vision Status Flags (32 bits)
+1	Resv	Resv	Resv	Resv	Resv	Resv	Resv	Resv	Resv	Resv	Resv	Resv	Resv	Resv	Resv	GATE	
+2	Command code																Command code (32 bits)
+3																	
+4	Response code																Response code (32 bits)
+5																	
+6	Response data																Response data (32 bits)
+7																	

Signal	Signal name	Function	Application method
FLG	Control Command Completed	This signal turns ON when the Vision Sensor completes execution of the control command. (This signal turns ON after the control command code, response code, and response data have been stored.)	Command/ response communications
		This signal automatically turns OFF when the Control Command Execution Bit (EXE) is turned OFF by the user (PLC).	
BUSY	Command Execution Active	This signal is ON while the Vision Sensor cannot execute a control command.	Command/ response communications
		This signal is OFF while the Vision Sensor can execute a control command.	

Signal	Signal name	Function	Application method
READY	Ready	This signal turns OFF when the Vision Sensor cannot execute a control command.	Command/ response communications
		This signal turns ON when the Vision Sensor can execute a control command.	
OR	Overall judgement	This signal turns ON when the overall judgement is NG. Even if the OR output of parallel signals is set for a one-shot output, this signal will not be output at the same time.	Command/ response communications
		This signal turns OFF when overall judgement is OK.	
ERR	Error	This signal turns ON when an error is detected in the Vision Sensor.	Sensor status change output
		This signal is OFF while the Vision Sensor is operating normally.	
RUN	Run Mode	This signal is ON while the Vision Sensor is in Run Mode.	Sensor status change output
		This signal is OFF while the Vision Sensor is not in Run Mode.	
GATE	Data Output Completed	This signal turns ON when the Vision Sensor finishes outputting data.	Data output after measurements
		If [Handshake setting] is set to [Yes], this signal automatically turns OFF when the Data Output Request Bit (DSA) signal from the PLC turns OFF. If [Handshake setting] is set to [No], this signal turns OFF after the data output period has elapsed.	
Command code	Command code	This I/O port returns the command code that was executed.	Command/ response communications
Response code	Response code	This I/O port contains the response code of the executed command.	
Response data	Response data	This I/O port contains the response data of the executed command.	

### Important

If measurements are executed in parallel, the EtherNet/IP BUSY signal will also turn ON.

• Output Area

The output area is assigned immediately after the response area in I/O memory.

	Bits																Contents
	15	14	13	12	11	10	9	8	7	6	5	4	3	2	1	0	
+8	DATA 0																Output data 0 (32 bits)
+9																	
⋮	⋮																⋮
⋮																	
+22	DATA 7																Output data 7 (32 bits)
+23																	
⋮	⋮																⋮
⋮																	
+38	DATA 15																Output data 15 (32 bits)
+39																	
⋮	⋮																⋮
⋮																	
+70	DATA 31																Output data 31 (32 bits)
+71																	
⋮	⋮																⋮
⋮																	
+134	DATA 63																Output data 63 (32 bits)
+135																	

Signal	Signal name	Function	Application
DATA0-63	Output data 0 to 63	<p>These I/O ports output the output data that is specified for the data output method.</p> <p>The data that can be output is determined by the set value of the Output data size setting as follows:</p> <p>32 bytes: Output data 0 to 7            64 bytes: Output data 0 to 15            128 bytes: Output data 0 to 31            256 bytes: Output data 0 to 63</p>	Command/response communications

## Accessing Communications Areas Using Variables with NJ-series Controllers

With an NJ-series Controller, only variables can be used to access from the user program the I/O memory addresses that are assigned to the communications areas.

Use the following settings.

### ● Using Network Variables for Access

Create user-defined variables that match the structures of the communications areas of the Sensor.

Use the Sysmac Studio to define the variables.

Refer to the *Sysmac Studio Version 1 Operation Manual* (Cat. No. W504) for Sysmac Studio operating procedures.

## 1 Defining the Data Types of the Variables

Define data types for variables that match the structures of the communications areas.

### (1) Defining a Data Type for Signal Access

First, define a BOOL array data type to access the control signals and status signals.

Here, a data type called "U\_EIPFlag" is defined.

Name of data type: U\_EIPFlag

Type of derivative data type: Union

Name of data type	Data type	
U_EIPFlag	UNION	
F	ARRAY[0..31]OF BOOL	.....Specifies an array of BOOL data from 0 to 31.
W	DWORD	.....32-bit bit string data

### (2) Defining Data Types for Communications Area Access

Data types are defined to access the communications areas, with one data type for the command area and another data type for the response and output areas.

Here, data types called "S\_EIPOutput" and "S\_EIPInput" are defined.

#### • Data Type to Access the Command Area

Name of data type: S\_EIPOutput

Type of derivative data type: Structure

Name of data type	Data type	
S_EIPOutput	STRUCT	
ControlFlag	U_EIPFlag	.....The data type that was defined above (1)
CommandCode	DWORD	.....32-bit bit string data
CommandParam1	UDINT	.....32-bit integer data
CommandParam2	UDINT	.....32-bit integer data
CommandParam3	DINT	.....32-bit integer data

• Assignment Example for Variable Data Type That Matches the Command Area

		Bits																
		15	14	13	12	11	10	9	8	7	6	5	4	3	2	1	0	
S_EIP Output	Control Flag	+0	ERCLR	-	-	-	-	-	-	-	-	-	-	-	-	TRIG	EXE	
		+1	-	-	-	-	-	-	-	-	-	-	-	-	-	-	DSA	
	Command Code	+2	Command code															
		+3																
	Command Param1	+4	Parameter 1															
		+5																
	Command Param2	+6	Parameter 2															
		+7																
	Command Param3	+8	Parameter 3															
+9																		

• Data Type to Access the Response and Output Areas

Name of data type: S\_EIPInput

Type of derivative data type: Structure

Name of data type	Data type	
S_EIPInput	STRUCT	
StatusFlag	U_EIPFlag	.....The data type that was defined above (1)
CommandCodeEcho	DWORD	.....32-bit bit string data
ResponseCode	UDINT	.....32-bit integer data
ResponseData	DINT	.....32-bit integer data
OutputData	ARRAY[0..7]OF DINT	.....Specifies an array of DINT data from 0 to 7.

• Assignment Example for Variable Data Type That Matches the Response and Output Areas

		Bits																	
		15	14	13	12	11	10	9	8	7	6	5	4	3	2	1	0		
S_EIP Input	Status Flag	+0	ERR	-	-	-	-	-	-	-	-	-	RUN	OR	READY	BUSY	FLG		
		+1	-	-	-	-	-	-	-	-	-	-	-	-	-	-	GATE		
	Command CodeEcho	+2	Command code																
		+3																	
	Response Code	+4	Response code																
		+5																	
	Response Data	+6	Response data																
		+7																	
	Output Data	Output Area	+9	DATA0															
			+10																
			⋮																
		+25	DATA8																
		+26																	

## 2 Defining the Variables

Define variables for the data links for the communications area data that is used in EtherNet/IP communications.

These variables use the data types that were defined above in procedure 1.

Variable	Variable type	Network Publish attribute	Data type	Application
EIOutput	Global variable	Output	S_EIOutput	For data links to the command area
EIInput	Global variable	Input	S_EIInput	For data links to the response and output areas

## 3 Exporting the Variables That Were Defined on Sysmac Studio

Export the variables that you defined so that you can use them on the Network Configurator. An exported CSV file is created.

## 4 Network Configurator Settings

- (1) Import to the Network Configurator the CSV file that you exported from the Sysmac Studio. The variables that are imported will automatically be registered as tags.
- (2) Set the connections as shown in the following table.

Originator device (PLC) settings	Target device (Sensor) settings
Input tag set: EIOutput	Output tag set: Input101
Output tag set: EIInput	Input tag set: Output100

## 5 Accessing the Communications Areas from the User Program

The defined variables are used to access the communications areas for the Sensor using the following notation.

- Command Area

Signal name	Variable name
EXE	EIOutput.ControlFlag.F[0]
TRIG	EIOutput.ControlFlag.F[1]
ERCLR	EIOutput.ControlFlag.F[15]
DSA	EIOutput.ControlFlag.F[16]
Command code	EIOutput.CommandCode
Command parameter 1	EIOutput.CommandParam1
Command parameter 2	EIOutput.CommandParam2
Command parameter 3	EIOutput.CommandParam3



- Response Area

Signal name	Variable name
FLG	EIPInput.StatusFlag.F[0]
BUSY	EIPInput.StatusFlag.F[1]
READY	EIPInput.StatusFlag.F[2]
OR	EIPInput.StatusFlag.F[3]
RUN	EIPInput.StatusFlag.F[4]
ERR	EIPInput.StatusFlag.F[15]
GATE	EIPInput.StatusFlag.F[16]
Command code	EIPInput.CommandCodeEcho
Response code	EIPInput.ResposeCode
Response data	EIPInput.ResposeData

- Output Area

Signal name	Variable name
Output data 1	EIPInput.OutputData[0]
	⋮
Output data 8	EIPInput.OutputData[7]

- Accessing Communications Areas by Specifying I/O Memory Addresses

AT specifications can be set for variables to individually specify the I/O memory addresses that are assigned in the communications areas.

### 1 Setting Tag Sets (Network Configurator)

Specify the tag names in the PLC directly by using the I/O memory addresses that are assigned in the communications areas. (Output tags are specified for the input connections to the Sensor and input tags are specified for output connections to the PLC.)

Setting Examples

Output tag: D0

Input tag: D100

### 2 Setting Variables (Sysmac Studio)

Define variables with AT specifications to the I/O memory addresses that are assigned in the communications areas as shown below.

Setting Examples

Variable: *a* (AT specification: D0.0)

Variable: *b* (AT specification: D0.1)

Variable: *c* (AT specification: D0.15)

Variable: *d* (AT specification: D1.0)

### 3 Setting Connections

Set the connections as shown in the following table.

Originator device (PLC) settings	Target device (Sensor) settings
Input tag set: D0	Output tag set: Input101
Output tag set: D100	Input tag set: Output100

## Example: Setting Example for Variables to Access the Command Area

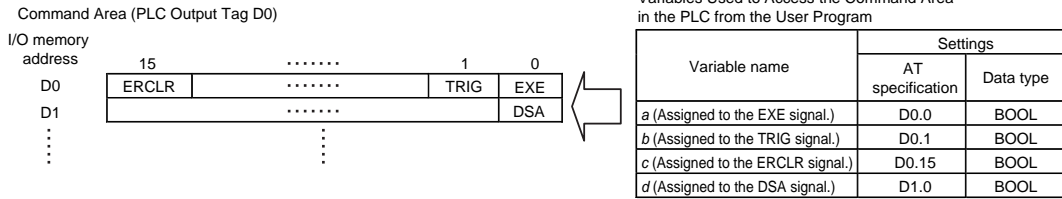

## Commands (EtherNet/IP)

This section describes the EtherNet/IP commands.

### ● Measurement Control Commands

Command code in command area (hex)	Command name	Function	Reference
00101020	Start Continuous Measurements	Executes continuous measurements.	p. 309
00101030	End Continuous Measurements	Ends continuous measurements.	p. 310

### ● Utility Commands

Command code in command area (hex)	Command name	Function	Reference
00102010	Clear Measurement Values	Clears all measurement result values.	p. 310
00102020	Clear Data Output Buffer	Clears all data in the data output buffer.	p. 311
00103010	Save Data in Sensor	Saves scene data and system data.	p. 311
00104010	Re-register Model	Registers the model again for registered Search Position Compensation, Shape Search II Position Compensation, Search, Shape Search II, or Sensitive Search inspection items.	p. 312
00104020	Teach	Executes teaching for all inspection items.	p. 312
0010F010	Reset	Resets the Vision Sensor.	p. 313
00205000	Get Latest Error Information	Acquires the latest error information.	p. 313

### ● Scene Control Commands

Command code in command area (hex)	Command name	Function	Reference
00201000	Get Scene Number	Acquires the current scene number.	p. 314
00301000	Select Scene	Changes to the specified scene number.	p. 314

● Data Acquisition/Setting Commands

Command code in command area (hex)	Command name	Function	Reference
00401010	Get Image Adjustment Data	Acquires data from a position compensation item or filter item.	p. 315
00501010	Set Image Adjustment Data	Sets the specified data in a position compensation item or filter item.	p. 315
00401020	Get Inspection Item Data	Acquires the inspection item data.	p. 316
00501020	Set Inspection Item Data	Sets the inspection item data to the specified data.	p. 317
00403000	Get Software Version Information	Acquires the software version.	p. 317

**Important**

After you execute the Reset command (0010F010 hex) for the Vision Sensor, turn OFF the EXE signal before the Vision Sensor restarts. If you leave the EXE signal ON, the Vision Sensor will restart repeatedly.

**Command Details**

● Start Continuous Measurements (Command Code: 0010 1020)

Command (PLC to Vision Sensor)

First word of command area	Bits				Contents
	12 to 15	8 to 11	4 to 7	0 to 3	
+2	0001	0000	0010	0000	Command code
+3	0000	0000	0001	0000	

Response (Vision Sensor to PLC)

First word of response area	Bits				Contents
	12 to 15	8 to 11	4 to 7	0 to 3	
+2	0001	0000	0010	0000	Command code
+3	0000	0000	0001	0000	The command code for which the response applies is stored.
+4	0000	0000	0000	0000	Response code
+5	0000	0000	0000	0000	Command execution result 0: OK, FFFFFFFF: NG

**Note**

The measurement results are written to the output area if data output is set.  
The measurement results are not output if data output is not set.



Setting the Data To Output Automatically after Measurements: p. 295

● End Continuous Measurements (Command Code: 0010 1030)

Command (PLC to Vision Sensor)

First word of command area	Bits				Contents
	12 to 15	8 to 11	4 to 7	0 to 3	
+2	0001	0000	0011	0000	Command code
+3	0000	0000	0001	0000	

Response (Vision Sensor to PLC)

First word of response area	Bits				Contents
	12 to 15	8 to 11	4 to 7	0 to 3	
+2	0001	0000	0011	0000	Command code
+3	0000	0000	0001	0000	The command code for which the response applies is stored.
+4	0000	0000	0000	0000	Response code
+5	0000	0000	0000	0000	Command execution result 0: OK, FFFFFFFF: NG

● Clear Measurement Values (Command Code: 0010 2010)

Command (PLC to Vision Sensor)

First word of command area	Bits				Contents
	12 to 15	8 to 11	4 to 7	0 to 3	
+2	0010	0000	0001	0000	Command code
+3	0000	0000	0001	0000	

Response (Vision Sensor to PLC)

First word of response area	Bits				Contents
	12 to 15	8 to 11	4 to 7	0 to 3	
+2	0010	0000	0001	0000	Command code
+3	0000	0000	0001	0000	The command code for which the response applies is stored.
+4	0000	0000	0000	0000	Response code
+5	0000	0000	0000	0000	Command execution result 0: OK, FFFFFFFF: NG

● Clear Data Output Buffer (Command Code: 2020 0010)

Command (PLC to Vision Sensor)

First word of command area	Bits				Contents
	12 to 15	8 to 11	4 to 7	0 to 3	
+2	0010	0000	0010	0000	Command code
+3	0000	0000	0001	0000	

Response (Vision Sensor to PLC)

First word of response area	Bits				Contents
	12 to 15	8 to 11	4 to 7	0 to 3	
+2	0010	0000	0010	0000	Command code
+3	0000	0000	0001	0000	The command code for which the response applies is stored.
+4	0000	0000	0000	0000	Response code
+5	0000	0000	0000	0000	Command execution result 0: OK, FFFFFFFF: NG

● Save Data in Sensor (Command Code: 0010 3010)

Command (PLC to Vision Sensor)

First word of command area	Bits				Contents
	12 to 15	8 to 11	4 to 7	0 to 3	
+2	0011	0000	0001	0000	Command code
+3	0000	0000	0001	0000	

Response (Vision Sensor to PLC)

First word of response area	Bits				Contents
	12 to 15	8 to 11	4 to 7	0 to 3	
+2	0011	0000	0001	0000	Command code
+3	0000	0000	0001	0000	The command code for which the response applies is stored.
+4	0000	0000	0000	0000	Response code
+5	0000	0000	0000	0000	Command execution result 0: OK, FFFFFFFF: NG

● Re-register Model (Command Code: 0010 4010)

Command (PLC to Vision Sensor)

First word of command area	Bits				Contents
	12 to 15	8 to 11	4 to 7	0 to 3	
+2	0100	0000	0001	0000	Command code
+3	0000	0000	0001	0000	

Response (Vision Sensor to PLC)

First word of response area	Bits				Contents
	12 to 15	8 to 11	4 to 7	0 to 3	
+2	0100	0000	0001	0000	Command code
+3	0000	0000	0001	0000	The command code for which the response applies is stored.
+4	0000	0000	0000	0000	Response code
+5	0000	0000	0000	0000	Command execution result 0: OK, FFFFFFFF: NG

● External Teaching (Command Code: 0010 4020)

Command (PLC to Vision Sensor)

First word of command area	Bits				Contents
	12 to 15	8 to 11	4 to 7	0 to 3	
+2	0100	0000	0010	0000	Command code
+3	0000	0000	0001	0000	

Response (Vision Sensor to PLC)

First word of response area	Bits				Contents
	12 to 15	8 to 11	4 to 7	0 to 3	
+2	0100	0000	0010	0000	Command code
+3	0000	0000	0000	0000	The command code for which the response applies is stored.
+4	0000	0000	0000	0000	Response code
+5	0000	0000	0000	0000	Command execution result 0: OK, FFFFFFFF: NG
+6	0000	0000	0000	0000	

● Reset Vision Sensor (Command Code: 0010 F010)

Command (PLC to Vision Sensor)

First word of command area	Bits				Contents
	12 to 15	8 to 11	4 to 7	0 to 3	
+2	1111	0000	0001	0000	Command code
+3	0000	0000	0001	0000	

Response (Vision Sensor to PLC)

First word of response area	Bits				Contents
	12 to 15	8 to 11	4 to 7	0 to 3	
There is no response for a reset operation.					

**Important**

If you leave the EXE signal ON when you use it to execute the Reset command, the Vision Sensor will restart repeatedly.

After you execute the Reset command, turn OFF the EXE signal before the Vision Sensor restarts.

● Get Latest Error Information (Command Code: 0020 5000)

Command (PLC to Vision Sensor)

First word of command area	Bits				Contents
	12 to 15	8 to 11	4 to 7	0 to 3	
+2	0101	0000	0000	0000	Command code
+3	0000	0000	0010	0000	

Response (Vision Sensor to PLC)

First word of response area	Bits				Contents
	12 to 15	8 to 11	4 to 7	0 to 3	
+2	0101	0000	0000	0000	Command code
+3	0000	0000	0010	0000	The command code for which the response applies is stored.
+4	0000	0000	0000	0000	Response code
+5	0000	0000	0000	0000	Command execution result 0: OK, FFFFFFFF: NG
+6	0000	0000	0000	0000	Response data
+7	0000	0000	0000	0000	Latest error code   Errors Stored in the Error History p. 398

● Get Scene Number (Command Code: 0020 1000)

Command (PLC to Vision Sensor)

First word of command area	Bits				Contents
	12 to 15	8 to 11	4 to 7	0 to 3	
+2	0001	0000	0000	0000	Command code
+3	0000	0000	0010	0000	

Response (Vision Sensor to PLC)

First word of response area	Bits				Contents
	12 to 15	8 to 11	4 to 7	0 to 3	
+2	0001	0000	0000	0000	Command code
+3	0000	0000	0010	0000	The command code for which the response applies is stored.
+4	0000	0000	0000	0000	Response code
+5	0000	0000	0000	0000	Command execution result 0: OK, FFFFFFFF: NG
+6	0000	0000	0000	0000	Response data
+7	0000	0000	0000	0000	Acquired scene number

● Select Scene (Command Code: 0030 1000)

Command (PLC to Vision Sensor)

First word of command area	Bits				Contents
	12 to 15	8 to 11	4 to 7	0 to 3	
+2	0001	0000	0000	0000	Command code
+3	0000	0000	0011	0000	
+4	0000	0000	0000	0000	Scene number
+5	0000	0000	0000	0000	

Response (Vision Sensor to PLC)

First word of response area	Bits				Contents
	12 to 15	8 to 11	4 to 7	0 to 3	
+2	0001	0000	0000	0000	Command code
+3	0000	0000	0011	0000	The command code for which the response applies is stored.
+4	0000	0000	0000	0000	Response code
+5	0000	0000	0000	0000	Command execution result 0: OK, FFFFFFFF: NG



● Get Image Adjustment Data (Command Code: 0040 1010)

Command (PLC to Vision Sensor)

First word of command area	Bits				Contents
	12 to 15	8 to 11	4 to 7	0 to 3	
+2	0001	0000	0001	0000	Command code
+3	0000	0000	0100	0000	
+4	0000	0000	0000	0000	Position compensation item/filter item number
+5	0000	0000	0000	0000	
+6	0000	0000	0000	0000	Data number
+7	0000	0000	0000	0000	

Response (Vision Sensor to PLC)

First word of response area	Bits				Contents
	12 to 15	8 to 11	4 to 7	0 to 3	
+2	0001	0000	0001	0000	Command code
+3	0000	0000	0100	0000	The command code for which the response applies is stored.
+4	0000	0000	0000	0000	Response code
+5	0000	0000	0000	0000	Command execution result 0: OK, FFFFFFFF: NG
+6	0000	0000	0000	0000	Acquired data (1,000 times the value)
+7	0000	0000	0000	0000	

● Set Image Adjustment Data (Command Code: 0050 1010)

Command (PLC to Vision Sensor)

First word of command area	Bits				Contents
	12 to 15	8 to 11	4 to 7	0 to 3	
+2	0001	0000	0001	0000	Command code
+3	0000	0000	0101	0000	
+4	0000	0000	0000	0000	Position compensation item/filter item number
+5	0000	0000	0000	0000	
+6	0000	0000	0000	0000	Data number
+7	0000	0000	0000	0000	
+8	0000	0000	0000	0000	Acquired data (1,000 times the value)
+9	0000	0000	0000	0000	

Response (Vision Sensor to PLC)

First word of response area	Bits				Contents
	12 to 15	8 to 11	4 to 7	0 to 3	
+2	0001	0000	0001	0000	Command code
+3	0000	0000	0101	0000	The command code for which the response applies is stored.
+4	0000	0000	0000	0000	Response code
+5	0000	0000	0000	0000	Command execution result 0: OK, FFFFFFFF: NG

● Get Inspection Item Data (Command Code: 0040 1020)

Command (PLC to Vision Sensor)

First word of command area	Bits				Contents
	12 to 15	8 to 11	4 to 7	0 to 3	
+2	0001	0000	0010	0000	Command code
+3	0000	0000	0100	0000	
+4	0000	0000	0000	0000	Inspection item number
+5	0000	0000	0000	0000	
+6	0000	0000	0000	0000	Data number
+7	0000	0000	0000	0000	

Response (Vision Sensor to PLC)

First word of response area	Bits				Contents
	12 to 15	8 to 11	4 to 7	0 to 3	
+2	0001	0000	0010	0000	Command code
+3	0000	0000	0100	0000	The command code for which the response applies is stored.
+4	0000	0000	0000	0000	Response code
+5	0000	0000	0000	0000	Command execution result 0: OK, FFFFFFFF: NG
+6	0000	0000	0000	0000	Acquired data
+7	0000	0000	0000	0000	(1,000 times the value)

● Set Inspection Item Data (Command Code: 0050 1020)

Command (PLC to Vision Sensor)

First word of command area	Bits				Contents
	12 to 15	8 to 11	4 to 7	0 to 3	
+2	0001	0000	0010	0000	Command code
+3	0000	0000	0101	0000	
+4	0000	0000	0000	0000	Inspection item number
+5	0000	0000	0000	0000	
+6	0000	0000	0000	0000	Data number
+7	0000	0000	0000	0000	
+8	0000	0000	0000	0000	Acquired data (1,000 times the value)
+9	0000	0000	0000	0000	

Response (Vision Sensor to PLC)

First word of response area	Bits				Contents
	12 to 15	8 to 11	4 to 7	0 to 3	
+2	0001	0000	0010	0000	Command code
+3	0000	0000	0101	0000	The command code for which the response applies is stored.
+4	0000	0000	0000	0000	Response code
+5	0000	0000	0000	0000	Command execution result 0: OK, FFFFFFFF: NG

● Get Software Version Information (Command Code: 0040 3000)

Command (PLC to Vision Sensor)

First word of command area	Bits				Contents
	12 to 15	8 to 11	4 to 7	0 to 3	
+2	0011	0000	0000	0000	Command code
+3	0000	0000	0100	0000	

Response (Vision Sensor to PLC)

First word of response area	Bits				Contents
	12 to 15	8 to 11	4 to 7	0 to 3	
+2	0011	0000	0000	0000	Command code
+3	0000	0000	0100	0000	The command code for which the response applies is stored.
+4	0000	0000	0000	0000	Response code
+5	0000	0000	0000	0000	Command execution result 0: OK, FFFFFFFF: NG
+6	0000	0000	0000	0000	Response data
+7	0000	0000	0000	0000	Software version (1,000 times the value)

## Timing Chart for EtherNet/IP Communications

### ● Performing Measurements with the TRIG Signal

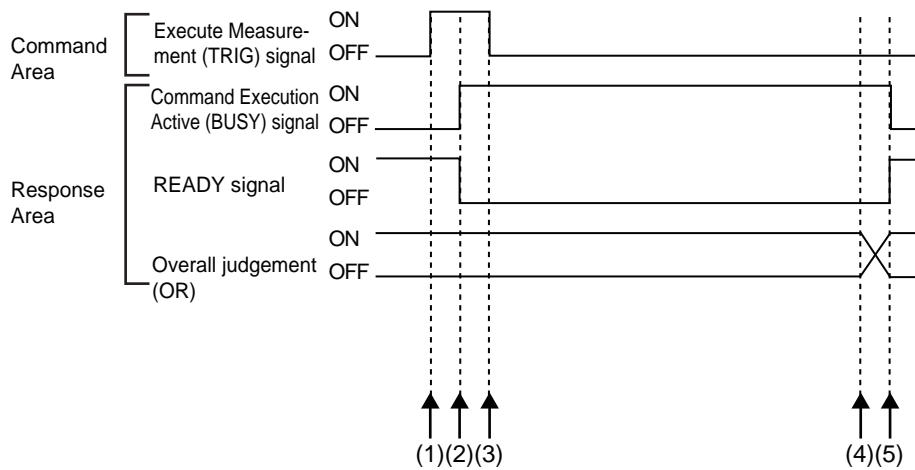

- (1) Measurement starts when the TRIG signal turns ON while the BUSY signal is OFF.
- (2) The BUSY signal turns ON when measurement begins.
- (3) The TRIG signal turns OFF when the BUSY signal turns ON.
- (4) The OR of the measurement results is output when measurements are completed.
- (5) The BUSY signal turns OFF when the BUSY output condition is met.

● Execution of Control Commands Other Than Continuous Measurements with the Control Command Execution Bit (EXE) Signal

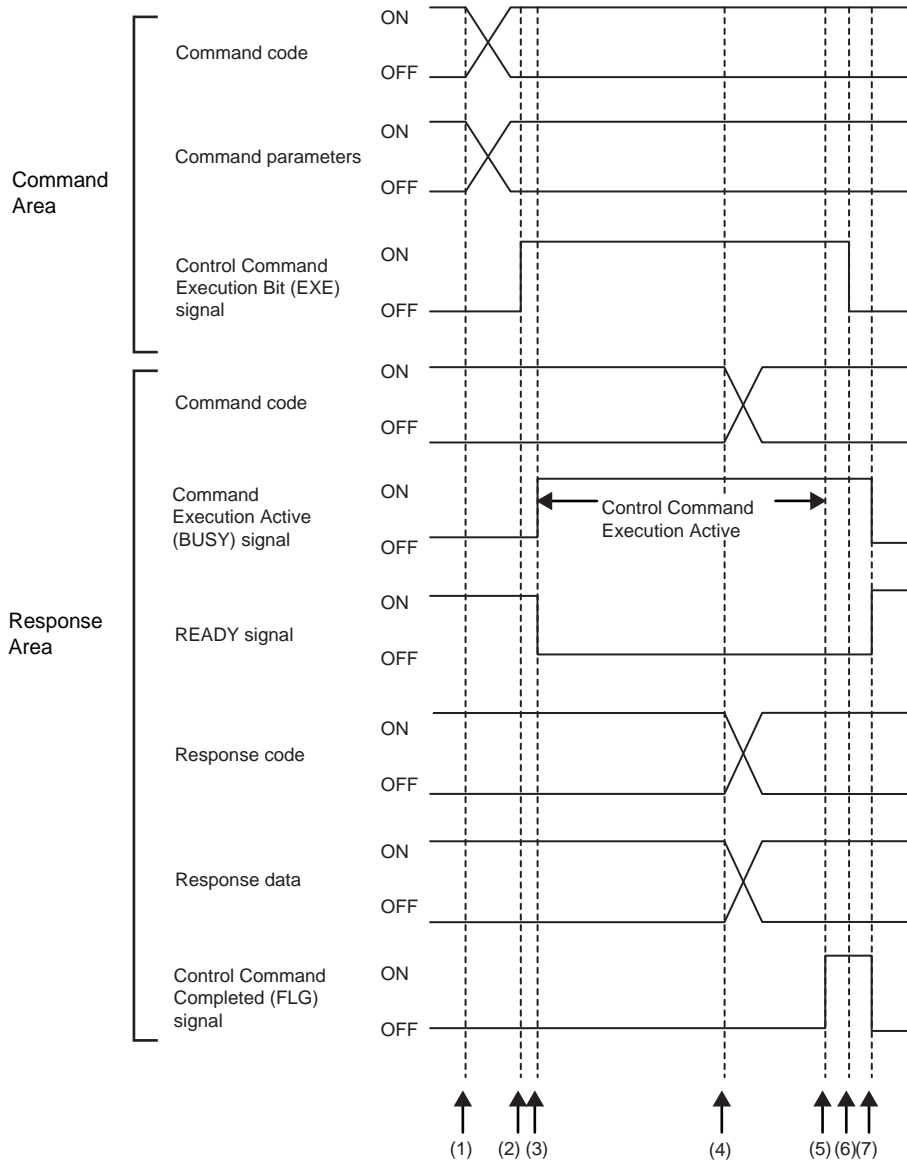

- (1) Set the command code and the command parameters from the PLC while the BUSY signal is OFF.
- (2) The Controller turns ON the Control Command Execution Bit (EXE) signal. The execution command is sent to the Vision Sensor.
- (3) When the Vision Sensor receives the execution command, the Command Execution Active (BUSY) signal turns ON, the READY signal turns OFF, and the command is executed.
- (4) The command code, response code, and response data are set when the Vision Sensor completes execution of the command.
- (5) The Control Command Completed (FLG) signal turns ON.
- (6) When the PLC detects that the Control Command Completed (FLG) signal is ON, it turns OFF the Control Command Execution Bit (EXE) signal.
- (7) When the Vision Sensor detects that the Control Command Execution Bit (EXE) signal is OFF, it automatically turns OFF the Control Command Completed (FLG) signal and the Command Execution Active (BUSY) signal, and turns ON the READY signal.

● Execution of Control Commands for Continuous Measurements with the Control Command Execution Bit (EXE) Signal

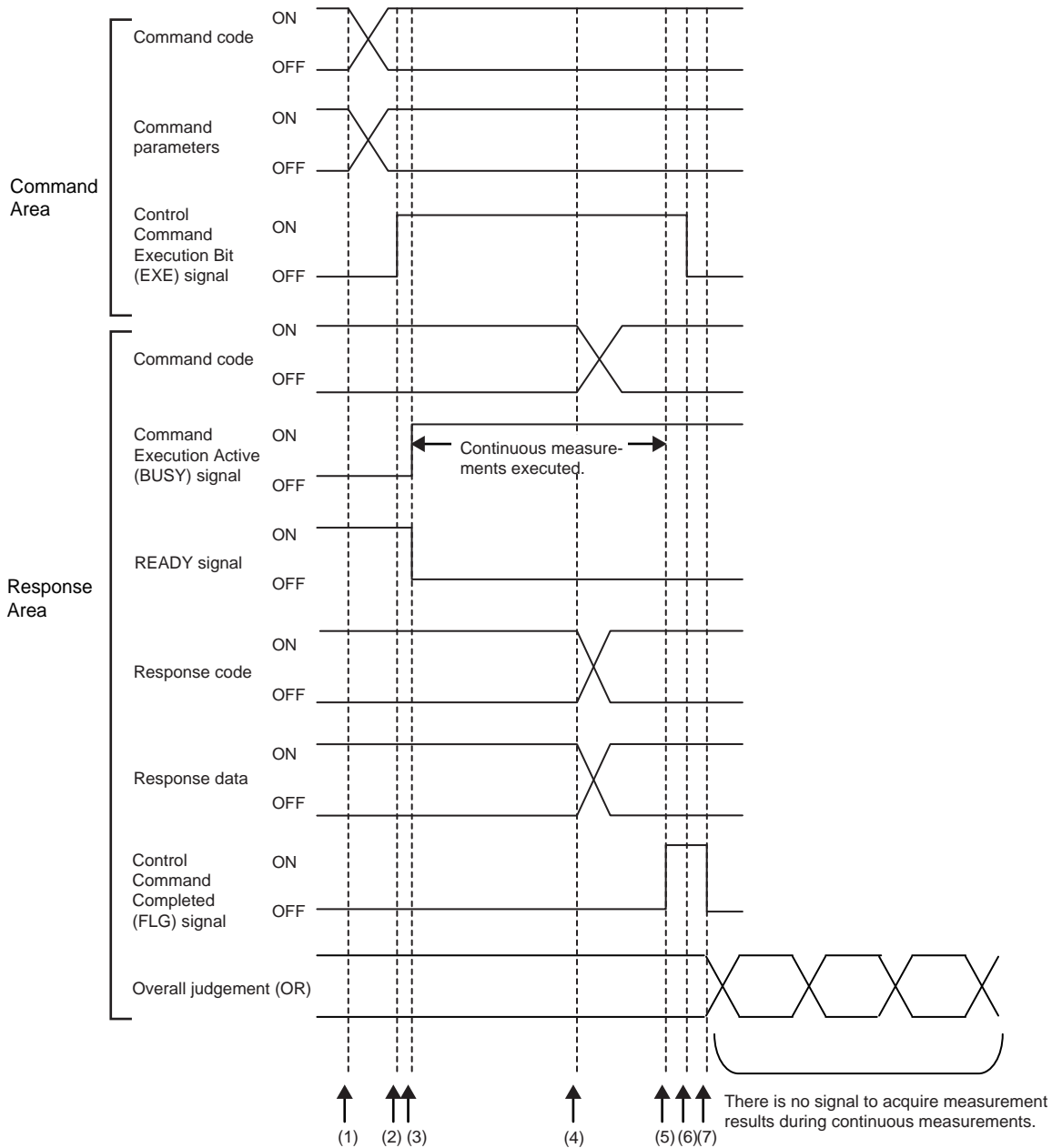

- (1) Set the Start Continuous Measurements command code and the command parameters from the PLC while the BUSY signal is OFF.
- (2) The Controller turns ON the Control Command Execution Bit (EXE) signal. The execution command is sent to the Vision Sensor.
- (3) When the Vision Sensor receives the execution command, the Command Execution Active (BUSY) signal turns ON, the READY signal turns OFF, and the command is executed. Continuous measurements start at this time.
- (4) The command code, response code, and response data are set when the Vision Sensor completes execution of the command.
- (5) The Control Command Completed (FLG) signal turns ON.
- (6) When the PLC detects that the Control Command Completed (FLG) signal is ON, it turns OFF the Control Command Execution Bit (EXE) signal.
- (7) When the Vision Sensor detects that the Control Command Execution Bit (EXE) signal is OFF, it automatically turns OFF the Control Command Completed (FLG) signal. The BUSY signal remains ON until continuous measurements are completed.
- (8) During continuous measurements, an OR of the measurement results is output each time a measurement is completed.

**Note**

During execution of continuous measurements, the BUSY signal remains ON. The Vision Sensor will acknowledge the EXE signal only after the End Continuous Measurements command is executed.

● Data Output after Measurements When Handshaking Is Enabled

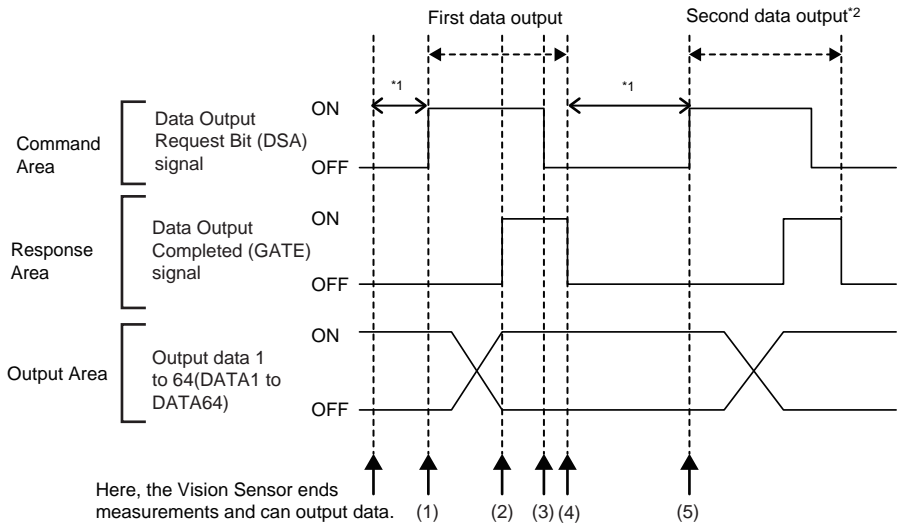

- (1) After measurements are completed, the Data Output Request Bit (DSA) signal is turned ON by the PLC and a request is made to the Vision Sensor to output the data.
- (2) The Vision Sensor outputs the data. After the data is output, the Data Output Completed (GATE) signal turns ON.
- (3) The master confirms that the Data Output Completed (GATE) signal has turned ON, loads the data, and turns OFF the Data Output Request Bit (DSA) signal.
- (4) When the Vision Sensor detects that the Data Output Request (DSA) signal is OFF, it automatically turns OFF the Data Output Completed (GATE) signal.
- (5) The Data Output Request Bit (DSA) signal is turned ON from the PLC and a request is made to output the data.

\*1 If the data output request signal is not manipulated within the control timeout time (100 to 120,000 ms) in the EtherNet/IP settings, and data output error will occur and the ERR signal will turn ON. When the ERCLR signal is turned ON, the ERR signal will turn OFF. However, if a timeout occurs again, the ERR signal will turn ON again. Therefore, correctly request data output (DSA control) or execute a Clear Data Output Buffer command.

\*2 Indicates that the data to output is separated and output more than once.

● Data Output after Measurements When Handshaking Is Disabled

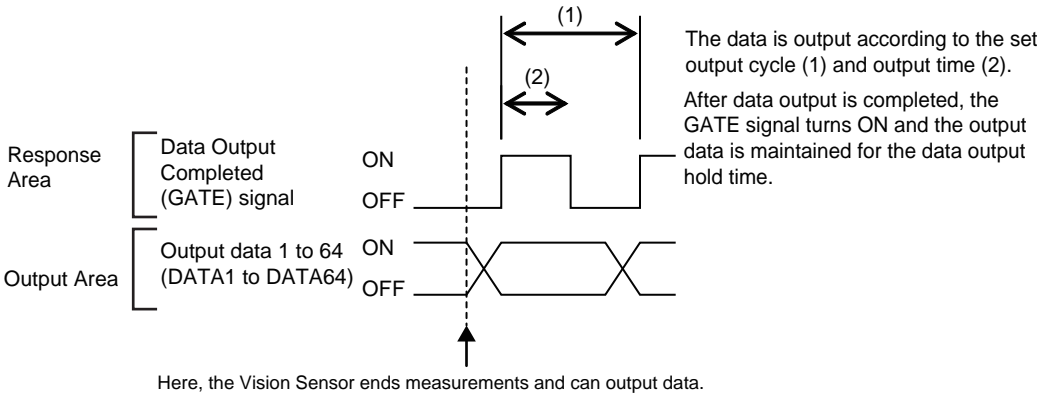

## Important

Set the parameters so that the following conditions are met for the data output period and time.

- Set the timeout time in the connection settings<sup>\*1</sup> between the PLC and Sensor so that it is longer than the measurement processing time of the Sensor.
- Set the data output period so that it is longer than the GATE signal ON period and shorter than the measurement interval of the Sensor.
- Set the GATE signal ON period so that it is longer than the cycle time of the PLC and longer than the packet interval (RPI).
- When operating under high-load conditions, a considerable leeway is required in the measurement interval to enable stable communications.
- On a network to which many devices are connected, performance may drop (e.g., responses may be delayed or packets lost) or communications errors may occur when there is temporarily high traffic on the network. Test the operation under actual conditions before you start actual operation of the system.
- If the measurement interval is short, communications errors may occur depending on the measurement processing time of the Sensor and the settings in the PLC. Set the timeout time in the connection settings<sup>\*1</sup> so that it is longer than the measurement processing time of the Sensor or increase the measurement interval.

\*1 These are the connection settings for tag data links. Make these settings from the Network Configurator.



## Sample Ladder Programming

### ● Command/Response Communications

The following sample program is used to clear measurement values.

The Clear Measurement Values command (lower bytes: #2010, upper bytes: #0010) is sent to the Vision Sensor.

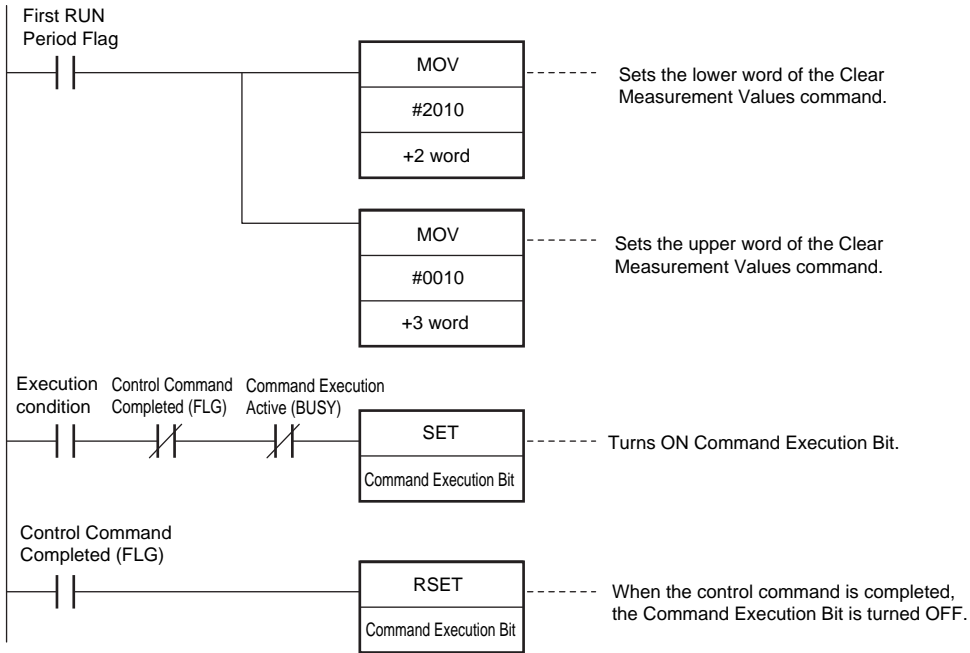

### Important

Create the ladder program to control the TRIG signal so that it does not turn ON while the BUSY signal is ON. If not, a TRIG input error will occur and the ERROR signal will turn ON.

### Note

While the trigger input (TRIG signal) for parallel measurements is ON, the EtherNet/IP BUSY signal will also be ON. Therefore, no EtherNet/IP commands will be executed. Any EtherNet/IP commands will be executed after execution of the parallel commands. You can also use a EtherNet/IP to perform measurements and output data with the parallel I/O measurement trigger signal (TRIG).

### ● Data Output after Measurements When Handshaking Is Enabled

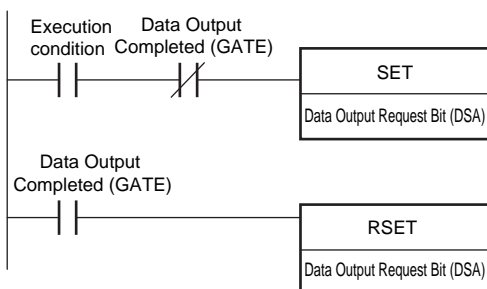

# 9-3 PLC Link Connections

You can use a PLC Link to communicate between the PLC and the Vision Sensor to perform control via command/response communications or to output data after measurements. You can use these communications methods simultaneously.

### ● Command/Response Communications

For PLC Link communications, command/response control signals are handled by storing control commands from the PLC to the Vision Sensor and responses from the Vision Sensor to the PLC in the I/O memory of the PLC. This allows you to control the operation of the Vision Sensor (e.g., perform single inspections or change the scene) without using communications instructions.

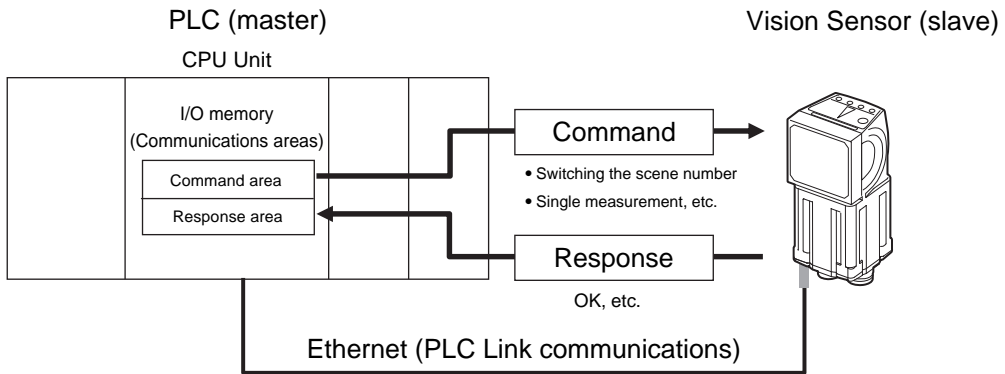

After you write a control command to the specified Command Area in the I/O memory of the PLC, you can turn ON the Command Execution (EXE) Bit to send the control command to the Vision Sensor via Ethernet. The Vision Sensor executes the control command and sends a response back to the PLC via Ethernet. The PLC stores the response in the specified Response Area in I/O memory.

### ● Data Output after Measurements

Immediately after a single measurement or continuous measurements, the Vision Sensor will automatically output to the specified I/O memory in the PLC the data for measurements that are specified for output in advance. This enables you to easily transfer the measurement results data for inspection items to the PLC. When handshaking is enabled, the data can be output from the Vision Sensor only when the condition to receive that data are met at the PLC.

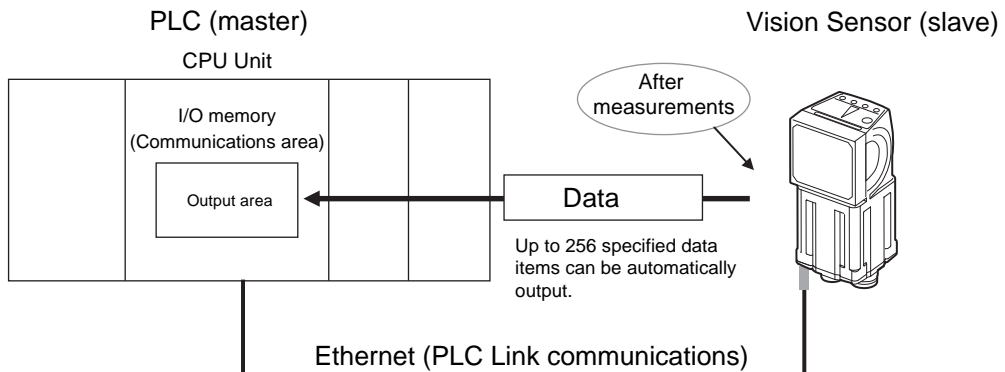

You must specify in advance the data to output after measurements. You must also specify in advance the Output Area in I/O memory to store the data in the PLC. After a single measurement or continuous measurements, the data is automatically stored in the Output Area of the PLC via Ethernet.

For PLC Link communications, the following three communications areas are set in the PLC to perform communications.

Command/response communications	1. Command area	This is the area to which you write control commands for the Vision Sensor to execute.
	2. Response area	This is the area to which the Vision Sensor writes the results of control commands executed from the Command Area.
Data output after measurements	3. Output area	This is the area to which the Vision Sensor writes output data for measurements after an inspection is performed.

You can set the area and address settings in the communications specifications of the Vision Sensor to assign the above three communications areas in the I/O memory of the PLC.

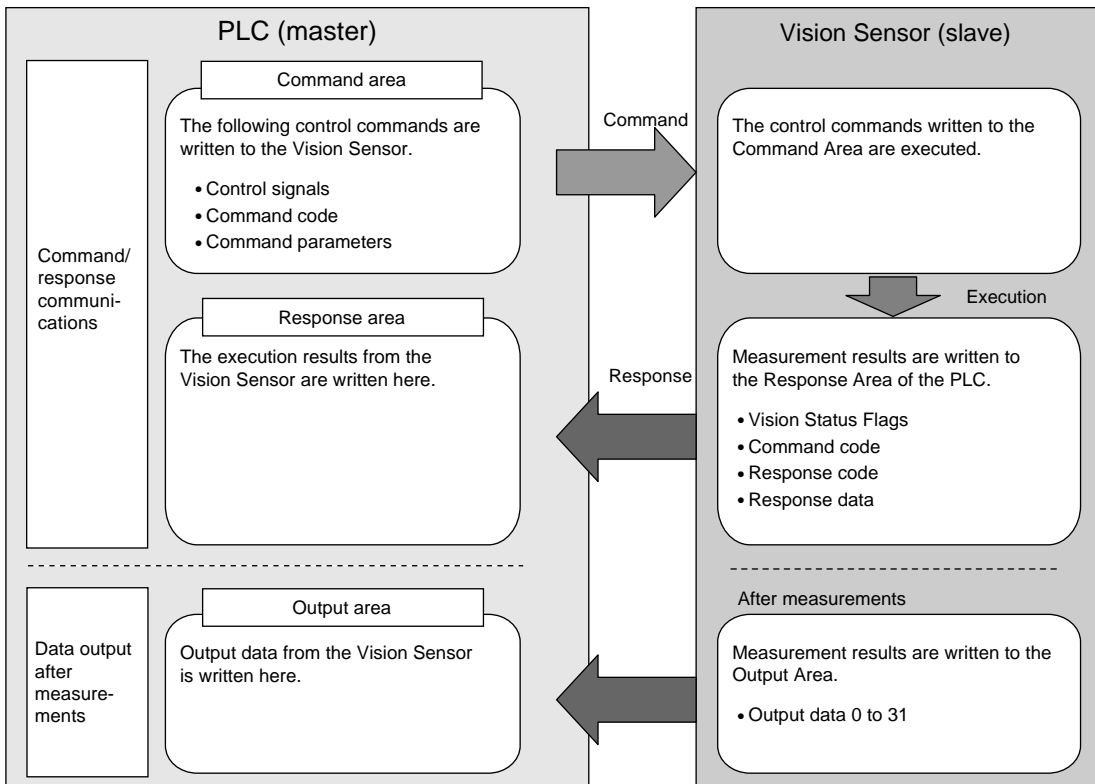

**Note**

A PLC Link uses three link areas to perform communications: the Command Area, Response Area, and Output Area. A PLC Link is not the same as the Serial PLC Link protocol used to connect PLCs together with serial communications.

**Important**

- An FQ2 Sensor operates as a TCP server. Therefore, the TCP connection must be made from the PLC. Refer to the manual for the PLC for TCP connection methods.
- The port number on the FQ2 Vision Sensor is always 9877.

## PLC Link-compatible Models

### ● OMRON

Series	CPU	Interface	
		Built-in port in CPU Unit	Ethernet Unit
SYSMAC CJ2	CJ2, CJ2M	Supported (Built-in port only)	CJ1W-EIP21, CJ1W-ETN21
SYSMAC CJ1	CJ1H, CJ1G	---	CJ1W-EIP21, CJ1W-ETN21
	CJ1M	Supported (Built-in port only)	CJ1W-EIP21, CJ1W-ETN21
SYSMAC CS	CS1H, CS1D, CS1G	---	CS1W-EIP21, CS1W-ETN21
SYSMAC CP1	CP1L	---	CP1W-CIF41
	CP1H	---	CP1W-CIF41
SYSMAC One	NSJ	Supported (Built-in port only)	NSJW-ETN21

### ● Mitsubishi Electric Corporation

Series	Model name	CPU name	CPU	Interface	
				Built-in port in CPU Unit	Ethernet Unit
MELSEC-QnU	Universal model	QnUDECPU	Q03UDECPU, Q04UDECPU, Q06UDECPU, Q10UDECPU, Q13UDECPU, Q20UDECPU, Q26UDECPU	Supported	QJ71E71-100, QJ71E71-B2, QJ71E71-B5
		QnUDCPU	Q03UDCPU, Q04UDCPU, Q06UDCPU, Q10UDCPU, Q13UDCPU, Q20UDCPU, Q26UDCPU	---	
		QnUCPU	Q00UJCPU, Q00UCPU, Q01UCPU, Q02UCPU	---	
	Basic model	QnCPU	Q00JCPU, Q00CPU, Q01CPU	---	
MELSEC-Q	High-performance model	QCPU	Q02CPU, Q02HCPU, Q06HCPU, Q12HCPU, Q25HCPU	---	A1SJ71QE71N3-T

Series	Model name	CPU name	CPU	Interface	
				Built-in port in CPU Unit	Ethernet Unit
MELSEC-QnAS	---	---	Q2ASCPU, Q2ASCPU-S1, Q2ASHCPU, Q2ASHCPU-S1	---	A1SJ71QE71N3-T



## Setting Up PLC Link Communications

### Setting Network Settings in the Sensor

This section describes how to set the IP address and other network settings in the Vision Sensor. Refer to the following section for details.

 2-5 Setting Up Ethernet: p. 53

#### Important

- Changes to settings are not applied until the Vision Sensor is restarted. Therefore, save the settings and then restart the Vision Sensor.
  -  5-5 Saving Data to the Sensor p. 178
  -  Restarting the Sensor p. 229
- The port number on the FQ2 Vision Sensor is always 9877.

### Initial Settings for PLC Link Communications

You must set the IP address of the PLC to connect to, assign the Command Area, Response Area, and Output Area, and make other settings to perform PLC Link communications.

▶  (Setup Mode) – [Sensor settings] – [Data output] – [Link data output]

- 1 Press [Communication type].
- 2 Press [PLC link (SYSMAC)] or [PLC link (MELSEC)] depending on the PLC that is connected.
- 3 Press [Area settings].

Here, you specify the addresses in the I/O memory of the PLC that are to be allocated as the communications areas for PLC Link communications.

Press [Command], [Response], and [Output] and set the memory area ([Area type]) and first word ([Address]) in the I/O memory of the PLC to allocate to each of these communications areas. When you are finished, press [Back].

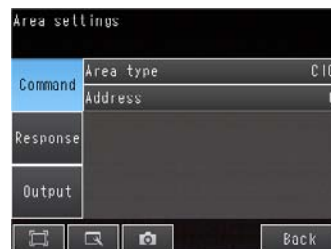

Item		Description	Setting range
Command (command area)	Area type	Select the area for the Command Area in the PLC.	If PLC Link (SYSMAC) is selected: CIO Area (CIO) Work Area (WR) Holding Bit Area (HR) Auxiliary Bit Area (AR) DM Area (DM) EM Area (EM0 to EMC) Default: CIO Area (CIO)  If PLC Link (MELSEC) is selected: Data Register (Data registers) File Register (File registers) Link Register (Link registers) Default: Data Register
	Address	Set the first address of the command area in the PLC.	0 to 99,999 Default: 0
Response (response area)	Area type	Set the PLC memory area for the response area.	Same as for the Command Area.
	Address	Set the first address of the response area in the PLC.	0 to 99,999 Default: 100
Output (output area)	Area type	Set the PLC memory area for the output area.	Same as for the Command Area.
	Address	Set the first address of the output area in the PLC.	0 to 99,999 Default: 200

#### 4 Set the communications protocol ([Communication type]) to PLC Link communications.

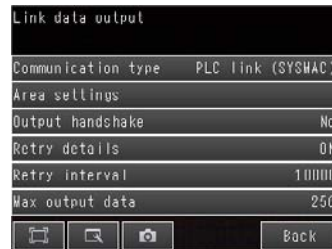

Item	Description	Setting range
Output handshake	Enables or disables handshaking. • Yes: Data is output when the DSA signal from the PLC turns ON. • No: Data is output regardless of the signal state from the PLC.	No or Yes Default: No
Retry details	Enables or disables retrying communications.	ON or OFF Default: OFF
Retry interval	Sets the interval for retrying communications. This setting is enabled only when [Retry details] is set to [ON].	0 to 2,147,483,647 ms Default: 10,000 ms
Max output data	Sets the maximum data size that can be output at one time through PLC Link communications. Set the number of bytes. Any output data that is beyond this value is discarded.	32 to 1,024 bytes Default: 256 bytes
Connection mode	Sets the TPC connection mode.	TCP server or TCP client Default: TCP server

**Important**

Changes to settings are not applied until the Vision Sensor is restarted. Therefore, save the settings and then restart the Vision Sensor.

 5-5 Saving Data to the Sensor p. 178

 Restarting the Sensor p. 229

## Setting the Data To Output Automatically after Measurements

You can set in advance the data to output automatically after measurements. (You can set up to 32 data items.)

### Data That Can Be Output

You can output up to 32 data items (data 0 to data 31). The measurement data from inspection items that can be output and the calculation results from the expression settings can be output. For data that can be output, refer to the *Measurement Data That Can Be Used for External Outputs and Calculations* for each inspection item.

### Assigning Inspection Results to Output Data

You can individually assign the parameters of the inspection items to output data (data 0 to data 31). The following procedure shows how to assign the measured position X of [0. Search] to data 0 for a binary output.

#### ► [In/Out] – [I/O setting] – [Output data setting] – [Link data output] – [Output data set]

- 1 Press [0. Data 0].
- 2 Press [Data setting].
- 3 Press [I0. Search].
- 4 Press [Position X X].

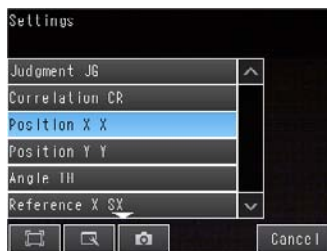

- 5 If the inspection item allows multi-point output, press the number ([0] to [30]) of the inspection result for which to output the data from the list of inspection results.  
To register something to data 1 and higher, repeat this process.  
The settings will be enabled after you restart the Sensor.

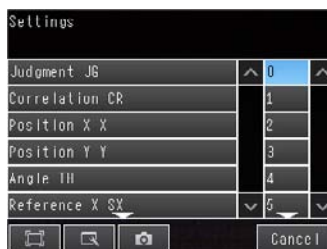

## Assigning More Than One Inspection Result to the Same Output Data

You can assign more than one inspection result to the same data output to output all of the assigned results. This is possible for the following inspection results.

- Parameters for the same inspection item: You can assign up to five inspection results.
- Inspection results that support multi-point output: You can assign inspection results within the specified range (0 to 31).

The following procedure shows how to assign more than one inspection result to data 0.

### ► [In/Out] – [I/O settings] – [Output data setting] – [Link data output] – [Output data set]

- 1 Press [0. Data 0].
- 2 Press [Multi-data].
- 3 Set the following items on the display to set expressions.



Item	Description
Expression	Register the expression to use to output multiple data. Examples: LPR (0, 3, I0.X, I0.Y) LPC (0, I0.C, I0.X, I0.Y)
Const.	Used to insert numbers and symbols into the expression.
Data	Used to select the inspection items for which to output data and insert the parameters to output into the expression. Example: Selecting Parameters for the Search Item at Inspection Item 0 Inspection item: I0. Search Judgement result: Judgement JG, Correlation: Corre. CR
Math.	Either of the following two functions can be inserted. <ul style="list-style-type: none"> <li>• LPR function (order of the measurement data) The measurement data is output in order. Format: LPR(<i>start_number</i>,<i>number_of_data</i>,<i>data_1</i>, <i>data_2</i>,...<i>data_5</i>) You can omit data 2 to data 5.</li> <li>• LPC function (order of the detection points) Data is output for each detected measurement point. Format: LPC(<i>start_number</i>,<i>number_of_data</i>,<i>data_1</i>, <i>data_2</i>,...<i>data_5</i>) You can omit data 2 to data 5.</li> </ul>

**To register something to data 1 and higher, repeat this process.  
The settings will be enabled after you restart the Sensor.**



● Expression Setting Example

This example registers an expression to output the following inspection results for data 0.

Inspection item: 0 Search

Parameters to output: Position X, Position Y, Reference SX, and Reference SY

Multi-point output setting: Multi-point output Check Box selected, Count = 4

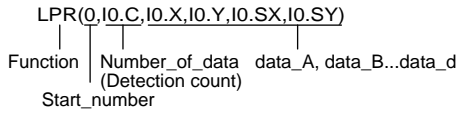

Output Results

The expression that is registered for data 0 assigns the data for 16 items (64 bytes) in the output area as shown below.

Output area data	Assigned data
Output data 0 (4 bytes)	I0.X[0] (Position X 1st point)
Output data 1 (4 bytes)	I0.Y[0] (Position Y 1st point)
Output data 2 (4 bytes)	I0.SX[0] (Reference SX 1st point)
Output data 3 (4 bytes)	I0.SY[0] (Reference SY 1st point)
Output data 4 (4 bytes)	I0.X[1] (Position X 2nd point)
Output data 5 (4 bytes)	I0.Y[1] (Position Y 2nd point)
Output data 6 (4 bytes)	I0.SX[1] (Reference SX 2nd point)
Output data 7 (4 bytes)	I0.SY[1] (Reference SY 2nd point)
Output data 8 (4 bytes)	I0.X[2] (Position X 3rd point)
Output data 9 (4 bytes)	I0.Y[2] (Position Y 3rd point)
Output data 10 (4 bytes)	I0.SX[2] (Reference SX 3rd point)
Output data 11 (4 bytes)	I0.SY[2] (Reference SY 3rd point)
Output data 12 (4 bytes)	I0.X[3] (Position X 4th point)
Output data 13 (4 bytes)	I0.Y[3] (Position Y 4th point)
Output data 14 (4 bytes)	I0.SX[3] (Reference SX 4th point)
Output data 15 (4 bytes)	I0.SY[3] (Reference SY 4th point)

**Note**

The inspection results will be output according to the sorting method that is set for multi-point output for the inspection item.

● Output Data Size and Number of Output Data Upper Value Setting

When more than one inspection result is output, the size of the data that is output for the data output settings could exceed the limit that is set in the [Max output data] (number of output data upper value) parameter setting.

If that occurs, increase the set value of the number of output data upper value setting or adjust the output data settings so that data output size is not exceeded.

If the size of data that is output does exceed the set value of the [Max output data] (number of output data upper value) parameter setting, the remaining data will be discarded.

Example

Output data size: 328 bytes

Number of output data upper value setting: 256 bytes

Data Output Settings

Output data	Setting	
Data 0	I0.X[0]	Inspection item 0: Position X for Search
Data 1	I0.Y[0]	Inspection item 0: Position Y for Search
Data 2	LPC (0,30,I1.X,I1.Y)	Inspection item 1: Position X 1st point for Shape Search II
		Inspection item 1: Position X 30th point for Shape Search II
		Inspection item 1: Position Y 1st point for Shape Search II
		Inspection item 1: Position Y 30th point for Shape Search II
Data 3	LPR (0,10,I2.X,I2.Y)	Inspection item 2: Position X 1st point for Shape Search II
		Inspection item 2: Position Y 1st point for Shape Search II
		Inspection item 2: Position X 10th point for Shape Search II
		Inspection item 2: Position Y 10th point for Shape Search II

} 328 bytes

The output data that is assigned is output to the output area as shown below.

Any output data that exceeds the set value of the [Max output data] (number of output data upper value) parameter setting (256 bytes) is discarded.

Offset from first address in output area	Output data	Assigned output data
+0	Output data 0 (4 bytes)	Inspection item 0: Position X for Search
+1		
+2	Output data 1 (4 bytes)	Inspection item 0: Position Y for Search
+3		
+4	Output data 2 (4 bytes)	Inspection item 1: Position X 1st point for Shape Search II
+5		
⋮	⋮	⋮
+62	Output data 31 (4 bytes)	Inspection item 1: Position X 30th point for Shape Search II
+63		
+64	Output data 32 (4 bytes)	Inspection item 1: Position Y 1st point for Shape Search II
+65		
⋮	⋮	⋮
+122	Output data 61 (4 bytes)	Inspection item 1: Position Y 30th point for Shape Search II
+123		
+124	Output data 62 (4 bytes)	Inspection item 2: Position X 1st point for Shape Search II
+125		
+126	Output data 63 (4 bytes)	Inspection item 2: Position Y 1st point for Shape Search II
+127		
+128	Output data 64 (4 bytes)	Inspection item 2: Position X 2nd point for Shape Search II
+129		
⋮	⋮	⋮
+160	Output data 80 (4 bytes)	Inspection item 2: Position X 10th point for Shape Search II
+161		
+162	Output data 81 (4 bytes)	Inspection item 2: Position Y 10th point for Shape Search II
+163		

256 bytes  
(This data is output.)

72 bytes  
The data that exceeds the set upper limit is discarded.

## Setting the Output Format

► [In/Out] – [I/O setting] – [Output data setting] – [Link data output]

- 1** Press [Output format].
- 2** Press [Output form].
- 3** Set either a floating point decimal or a fixed decimal for the output form.

Item	Description	Setting range
Output form	Set the output form for numerical data.	Floating point or fixed point (default: fixed point)

## Memory Assignments for PLC Link Communications

This section describes the assignments for the Command, Response, and Data Output Areas.

### ● Command Area

PLC (Master) to Vision Sensor (Slave)

First word	Bits																Contents
	15	14	13	12	11	10	9	8	7	6	5	4	3	2	1	0	
+0	ERRCLR	Resv	Resv	Resv	Resv	Resv	Resv	Resv	Resv	Resv	Resv	Resv	Resv	Resv	Resv	EXE	Control signals (32 bits)
+1	Resv	Resv	Resv	Resv	Resv	Resv	Resv	Resv	Resv	Resv	Resv	Resv	Resv	Resv	Resv	DSA	
+2	Command code															Command code (32 bits)	
+3																	
+4	Parameter 1															Parameter (integer)	
+5																	
+6	Parameter 2															Spare (integer)	
+7																	
+8	Parameter 3															Spare (integer)	
+9																	

Signal	Signal name	Function	Application
EXE	Control Command Execution Bit	Turn ON this signal from the PLC to send a control command for the Vision Sensor to execute.	Command/response communications
		Turn OFF the EXE signal from the PLC when the Control Command Completed (FLG) signal from the Vision Sensor turns ON. (Set the control command code and parameters before you turn ON this signal.)	
DSA	Data Output Request Bit	Turn ON this signal from the PLC to request data output. When this signal turns ON, the Vision Sensor outputs data.	Data output after measurements
		Turn OFF the DSA signal from the PLC when the Data Output Completed (GATE) signal from the Vision Sensor turns ON.	
ERRCLR	Clear Error	Turn ON this signal to turn OFF the error (ERR) signal from the Vision Sensor.	Command/Response Communications
		Turn OFF this signal from PLC when the error (ERR) signal goes OFF.	
Command code	Command code	This I/O port stores the command code.	Command/Response Communications
Parameters 1 to 3	Command parameters	These I/O ports store the command parameters.	

● Response Area

Vision Sensor (Slave) to PLC (Master)

First word	Bits																Contents
	15	14	13	12	11	10	9	8	7	6	5	4	3	2	1	0	
+0	ERR	Resv	Resv	Resv	Resv	Resv	Resv	Resv	Resv	Resv	Resv	Resv	Resv	READY	BUSY	FLG	Control signals (32 bits)
+1	Resv	Resv	Resv	Resv	Resv	Resv	Resv	Resv	Resv	Resv	Resv	Resv	Resv	Resv	Resv	GATE	
+2	Command code															Command code (32 bits)	
+3																	
+4	Response code															Response code (32 bits)	
+5																	
+6	Response data															Response data (32 bits)	
+7																	

Signal	Signal name	Function	Application
FLG	Control Command Completed	This signal turns ON when the Vision Sensor completes execution of the control command.	Command/ response communications
		This signal automatically turns OFF when the Control Command Execution Bit (EXE) signal from the PLC turns OFF. This signal turns ON after the control command code, response code, and response data have been stored.	
BUSY	Command Execution Active	This signal is ON while the Vision Sensor is executing a control command.	
		It is OFF while the Vision Sensor is not executing a control command.	
READY	Ready	This signal turns ON when the Vision Sensor can execute a command.	Command/ response communications
		This signal turns OFF when the Vision Sensor cannot execute a command.	
ERR	Error	This signal turns ON when an error is detected in the Vision Sensor.	Command/ response communications
		<b>Important</b> This flag turns ON when an error occurs in PLC link communications. This signal will remain OFF for any errors other than PLC Link communications errors.	
		This signal turns OFF when the Clear Error (ERRCLR) signal from the PLC turns ON.	
GATE	Data Output Completed	This signal turns ON when the Vision Sensor finishes outputting data.	Data output after measurements
		If handshaking is enabled, the GATE signal turns OFF automatically when you turn OFF the Data Output Request (DSA) signal from the PLC.	

Signal	Signal name	Function	Application
Command code	Command code	This I/O port returns the command code that was executed.	Command/ response commu- nications
Response code	Response code	This I/O port contains the response code of the executed command.	
Response data	Response data	This I/O port contains the response data of the executed command.	

● Output Area

Vision Sensor (Slave) to PLC (Master)

First word	Bits															Contents
	15	14	13	12	11	10	9	8	7	6	5	4	3	2	1	
+0	DATA 0															Output data 0 (32 bits)
+1																
.	.															.
.																
.	.															.
.																
+14	DATA 7															Output data 7 (32 bits)
+15																
.	.															.
.																
.	.															.
.																
+128	DATA 63															Output data 63 (32 bits)
+129																
.	.															.
.																
.	.															.
.																
+512	DATA 255															Output data 255 (32 bits)
+513																

Signal	Signal name	Function	Application
DATA0-255	Output data 0 to 255	These I/O ports output the output data that is specified for the data output method. The range of the data that can be output is determined by the set value of the [Max output data] (number of output data upper value) parameter setting as follows: Minimum setting (32 bytes): Output data 0 to 7 Default setting (256 bytes): Output data 0 to 63 Maximum setting (1,024 bytes): Output data 0 to 255	Data output after measurements

**Note**

If the size of data that is output exceeds the set value of the number of output data upper value setting, the remaining data will be discarded.



Allocating Output Data p. 332

## Command Tables for PLC Link Communications

This section describes the commands used in PLC Link communications.

### ● Measurement Control Commands

First word of command area (hex)		Command name	Function	Reference
+2	+3			
1010	0010	Single Measurement	Performs a single measurement.	p. 338
1020	0010	Start Continuous Measurements	Executes continuous measurements.	p. 339
1030	0010	End Continuous Measurements	Ends continuous measurements.	p. 339

### ● Utility Commands

First word of command area (hex)		Command name	Function	Reference
+2	+3			
2010	0010	Clear Measurement Values	Clears all measurement result values.	p. 340
3010	0010	Save Data in Sensor	Saves the current system data and scene groups in the Sensor.	p. 340
4010	0010	Re-register Model	Registers the model again.	p. 340
4020	0010	External Teaching	Performs reteaching.	p. 341
F010	0010	Reset Vision Sensor	Resets the Vision Sensor.	p. 341

### ● Scene Control Commands

First word of command area (hex)		Command name	Function	Reference
+2	+3			
1000	0020	Get Scene Number	Acquires the current scene number.	p. 342
1000	0030	Select Scene	Changes to the specified scene number.	p. 342

● Data Acquisition/Setting Commands

First word of command area (hex)		Command name	Function	Reference
+2	+3			
1010	0040	Get Image Adjustment Data	Acquires data from a position compensation item or filter item.	p. 343
1010	0050	Set Image Adjustment Data	Sets the specified data in a position compensation item or filter item.	p. 343
1020	0040	Get Inspection Item Data	Acquires the inspection item data.	p. 344
1020	0050	Set Inspection Item Data	Sets the inspection item data to the specified data.	p. 345
3000	0040	Get Software Version Information	Acquires the software version.	p. 345
5000	0020	Get Latest Error Information	Acquires the latest error information.	p. 346

## Command Details

● Single Measurement (Command Code: 1010 0010)

Command (PLC to Vision Sensor)

First word of command area	Bits				Contents
	12 to 15	8 to 11	4 to 7	0 to 3	
+2	0001	0000	0001	0000	Command code: 4-byte binary data
+3	0000	0000	0001	0000	

Response (Vision Sensor to PLC)

First word of response area	Bits				Contents
	12 to 15	8 to 11	4 to 7	0 to 3	
+2	0001	0000	0001	0000	Command code The command code for which the response applies is stored.
+3	0000	0000	0001	0000	
+4	0000	0000	0000	0000	Response code Command execution result 0: OK, FFFFFFFF: NG
+5	0000	0000	0000	0000	

**Note**

The measurement results are written to the output area if data output is set.  
The measurement results are not output if data output is not set.



Setting the Data To Output Automatically after Measurements: p. 329



● Start Continuous Measurements (Command Code: 1020 0010)

Command (PLC to Vision Sensor)

First word of command area	Bits				Contents
	12 to 15	8 to 11	4 to 7	0 to 3	
+2	0001	0000	0010	0000	Command code
+3	0000	0000	0001	0000	

Response (Vision Sensor to PLC)

First word of response area	Bits				Contents
	12 to 15	8 to 11	4 to 7	0 to 3	
+2	0001	0000	0010	0000	Command code
+3	0000	0000	0001	0000	The command code for which the response applies is stored.
+4	0000	0000	0000	0000	Response code
+5	0000	0000	0000	0000	Command execution result 0: OK, FFFFFFFF: NG

**Note**

The measurement results are written to the output area if data output is set.  
The measurement results are not output if data output is not set.



Setting the Data To Output Automatically after Measurements: p. 329

● End Continuous Measurements (Command Code: 1030 0010)

Command (PLC to Vision Sensor)

First word of command area	Bits				Contents
	12 to 15	8 to 11	4 to 7	0 to 3	
+2	0001	0000	0011	0000	Command code
+3	0000	0000	0001	0000	

Response (Vision Sensor to PLC)

First word of response area	Bits				Contents
	12 to 15	8 to 11	4 to 7	0 to 3	
+2	0001	0000	0011	0000	Command code
+3	0000	0000	0001	0000	The command code for which the response applies is stored.
+4	0000	0000	0000	0000	Response code
+5	0000	0000	0000	0000	Command execution result 0: OK, FFFFFFFF: NG

● Clear Measurement Values (Command Code: 2010 0010)

Command (PLC to Vision Sensor)

First word of command area	Bits				Contents
	12 to 15	8 to 11	4 to 7	0 to 3	
+2	0010	0000	0001	0000	Command code
+3	0000	0000	0001	0000	

Response (Vision Sensor to PLC)

First word of response area	Bits				Contents
	12 to 15	8 to 11	4 to 7	0 to 3	
+2	0010	0000	0001	0000	Command code
+3	0000	0000	0001	0000	The command code for which the response applies is stored.
+4	0000	0000	0000	0000	Response code
+5	0000	0000	0000	0000	Command execution result 0: OK, FFFFFFFF: NG

● Save Data in Sensor (Command Code: 3010 0010)

Command (PLC to Vision Sensor)

First word of command area	Bits				Contents
	12 to 15	8 to 11	4 to 7	0 to 3	
+2	0011	0000	0001	0000	Command code
+3	0000	0000	0001	0000	

Response (Vision Sensor to PLC)

First word of response area	Bits				Contents
	12 to 15	8 to 11	4 to 7	0 to 3	
+2	0011	0000	0001	0000	Command code
+3	0000	0000	0001	0000	The command code for which the response applies is stored.
+4	0000	0000	0000	0000	Response code
+5	0000	0000	0000	0000	Command execution result 0: OK, FFFFFFFF: NG

● Re-register Model (Command Code: 4010 0010)

Command (PLC to Vision Sensor)

First word of command area	Bits				Contents
	12 to 15	8 to 11	4 to 7	0 to 3	
+2	0100	0000	0001	0000	Command code
+3	0000	0000	0001	0000	

Response (Vision Sensor to PLC)

First word of response area	Bits				Contents
	12 to 15	8 to 11	4 to 7	0 to 3	
+2	0100	0000	0001	0000	Command code The command code for which the response applies is stored.
+3	0000	0000	0001	0000	
+4	0000	0000	0000	0000	Response code
+5	0000	0000	0000	0000	Command execution result 0: OK, FFFFFFFF: NG

● External Teaching (Command Code: 4020 0010)

Command (PLC to Vision Sensor)

First word of command area	Bits				Contents
	12 to 15	8 to 11	4 to 7	0 to 3	
+2	0100	0000	0010	0000	Command code
+3	0000	0000	0001	0000	

Response (Vision Sensor to PLC)

First word of response area	Bits				Contents
	12 to 15	8 to 11	4 to 7	0 to 3	
+2	0100	0000	0010	0000	Command code The command code for which the response applies is stored.
+3	0000	0000	0001	0000	
+4	0000	0000	0000	0000	Response code
+5	0000	0000	0000	0000	Command execution result 0: OK, FFFFFFFF: NG

● Reset Vision Sensor (Command Code: F010 0010)

Command (PLC to Vision Sensor)

First word of command area	Bits				Contents
	12 to 15	8 to 11	4 to 7	0 to 3	
+2	1111	0000	0001	0000	Command code
+3	0000	0000	0001	0000	

Response (Vision Sensor to PLC)

First word of response area	Bits				Contents
	12 to 15	8 to 11	4 to 7	0 to 3	
There is no response for a reset operation.					

● Get Scene Number (Command Code: 1000 0020)

Command (PLC to Vision Sensor)

First word of command area	Bits				Contents
	12 to 15	8 to 11	4 to 7	0 to 3	
+2	0001	0000	0000	0000	Command code
+3	0000	0000	0010	0000	

Response (Vision Sensor to PLC)

First word of response area	Bits				Contents
	12 to 15	8 to 11	4 to 7	0 to 3	
+2	0001	0000	0000	0000	Command code
+3	0000	0000	0010	0000	The command code for which the response applies is stored.
+4	0000	0000	0000	0000	Response code
+5	0000	0000	0000	0000	Command execution result 0: OK, FFFFFFFF: NG
+6	0000	0000	0000	0000	Response data
+7	0000	0000	0000	0000	Acquired scene number

● Select Scene (Command Code: 1000 0030)

Command (PLC to Vision Sensor)

First word of command area	Bits				Contents
	12 to 15	8 to 11	4 to 7	0 to 3	
+2	0001	0000	0000	0000	Command code
+3	0000	0000	0011	0000	
+4	0000	0000	0000	0000	Scene number
+5	0000	0000	0000	0000	

Response (Vision Sensor to PLC)

First word of response area	Bits				Contents
	12 to 15	8 to 11	4 to 7	0 to 3	
+2	0001	0000	0000	0000	Command code
+3	0000	0000	0011	0000	The command code for which the response applies is stored.
+4	0000	0000	0000	0000	Response code
+5	0000	0000	0000	0000	Command execution result 0: OK, FFFFFFFF: NG

● Get Image Adjustment Data (Command Code: 1010 0040)

Command (PLC to Vision Sensor)

First word of command area	Bits				Contents
	12 to 15	8 to 11	4 to 7	0 to 3	
+2	0001	0000	0001	0000	Command code
+3	0000	0000	0100	0000	
+4	0000	0000	0000	0000	Position compensation item/filter item number
+5	0000	0000	0000	0000	
+6	0000	0000	0000	0000	Data number  12-2 External Reference Parameters p. 430
+7	0000	0000	0000	0000	

Response (Vision Sensor to PLC)

First word of response area	Bits				Contents
	12 to 15	8 to 11	4 to 7	0 to 3	
+2	0001	0000	0001	0000	Command code The command code for which the response applies is stored.
+3	0000	0000	0100	0000	
+4	0000	0000	0000	0000	Response code Command execution result 0: OK, FFFFFFFF: NG
+5	0000	0000	0000	0000	
+6	0000	0000	0000	0000	Acquired data (1,000 times the value)
+7	0000	0000	0000	0000	

● Set Image Adjustment Data (Command Code: 1010 0050)

Command (PLC to Vision Sensor)

First word of command area	Bits				Contents
	12 to 15	8 to 11	4 to 7	0 to 3	
+2	0001	0000	0001	0000	Command code
+3	0000	0000	0101	0000	
+4	0000	0000	0000	0000	Position compensation item/filter item number
+5	0000	0000	0000	0000	
+6	0000	0000	0000	0000	Data number  12-2 External Reference Parameters p. 430
+7	0000	0000	0000	0000	
+8	0000	0000	0000	0000	Acquired data (1,000 times the value)
+9	0000	0000	0000	0000	

Response (Vision Sensor to PLC)

First word of response area	Bits				Contents
	12 to 15	8 to 11	4 to 7	0 to 3	
+2	0001	0000	0001	0000	Command code
+3	0000	0000	0101	0000	The command code for which the response applies is stored.
+4	0000	0000	0000	0000	Response code
+5	0000	0000	0000	0000	Command execution result 0: OK, FFFFFFFF: NG

● Get Inspection Item Data (Command Code: 1020 0040)

Command (PLC to Vision Sensor)

First word of command area	Bits				Contents
	12 to 15	8 to 11	4 to 7	0 to 3	
+2	0001	0000	0010	0000	Command code
+3	0000	0000	0100	0000	
+4	0000	0000	0000	0000	Inspection item number
+5	0000	0000	0000	0000	
+6	0000	0000	0000	0000	Data number
+7	0000	0000	0000	0000	 12-2 External Reference Parameters p. 430

Response (Vision Sensor to PLC)

First word of response area	Bits				Contents
	12 to 15	8 to 11	4 to 7	0 to 3	
+2	0001	0000	0010	0000	Command code
+3	0000	0000	0100	0000	The command code for which the response applies is stored.
+4	0000	0000	0000	0000	Response code
+5	0000	0000	0000	0000	Command execution result 0: OK, FFFFFFFF: NG
+6	0000	0000	0000	0000	Acquired data (1,000 times the value)
+7	0000	0000	0000	0000	

● Set Inspection Item Data (Command Code: 1020 0050)

Command (PLC to Vision Sensor)

First word of command area	Bits				Contents
	12 to 15	8 to 11	4 to 7	0 to 3	
+2	0001	0000	0010	0000	Command code
+3	0000	0000	0101	0000	
+4	0000	0000	0000	0000	Inspection item number
+5	0000	0000	0000	0000	
+6	0000	0000	0000	0000	Data number  12-2 External Reference Parameters p. 430
+7	0000	0000	0000	0000	
+8	0000	0000	0000	0000	Value to set (1,000 times the value)
+9	0000	0000	0000	0000	

Response (Vision Sensor to PLC)

First word of response area	Bits				Contents
	12 to 15	8 to 11	4 to 7	0 to 3	
+2	0001	0000	0010	0000	Command code The command code for which the response applies is stored.
+3	0000	0000	0101	0000	
+4	0000	0000	0000	0000	Response code Command execution result 0: OK, FFFFFFFF: NG
+5	0000	0000	0000	0000	

● Get Software Version Information (Command Code: 3000 0040)

Command (PLC to Vision Sensor)

First word of command area	Bits				Contents
	12 to 15	8 to 11	4 to 7	0 to 3	
+2	0011	0000	0000	0000	Command code
+3	0000	0000	0100	0000	

Response (Vision Sensor to PLC)

First word of response area	Bits				Contents
	12 to 15	8 to 11	4 to 7	0 to 3	
+2	0011	0000	0000	0000	Command code The command code for which the response applies is stored.
+3	0000	0000	0100	0000	
+4	0000	0000	0000	0000	Response code Command execution result 0: OK, FFFFFFFF: NG
+5	0000	0000	0000	0000	
+6	0000	0000	0000	0000	Response data Software version (1,000 times the value)
+7	0000	0000	0000	0000	

● Get Latest Error Information (Command Code: 5000 0020)

Command (PLC to Vision Sensor)

First word of command area	Bits				Contents
	12 to 15	8 to 11	4 to 7	0 to 3	
+2	0101	0000	0000	0000	Command code
+3	0000	0000	0010	0000	

Response (Vision Sensor to PLC)

First word of response area	Bits				Contents
	12 to 15	8 to 11	4 to 7	0 to 3	
+2	0101	0000	0000	0000	Command code
+3	0000	0000	0010	0000	The command code for which the response applies is stored.
+4	0000	0000	0000	0000	Response code
+5	0000	0000	0000	0000	Command execution result 0: OK, FFFFFFFF: NG
+6	0000	0000	0000	0000	Response data
+7	0000	0000	0000	0000	Latest error code  Errors Stored in the Error History p. 398



# Timing Chart For PLC Link Communications

## ● Command/Response Communications

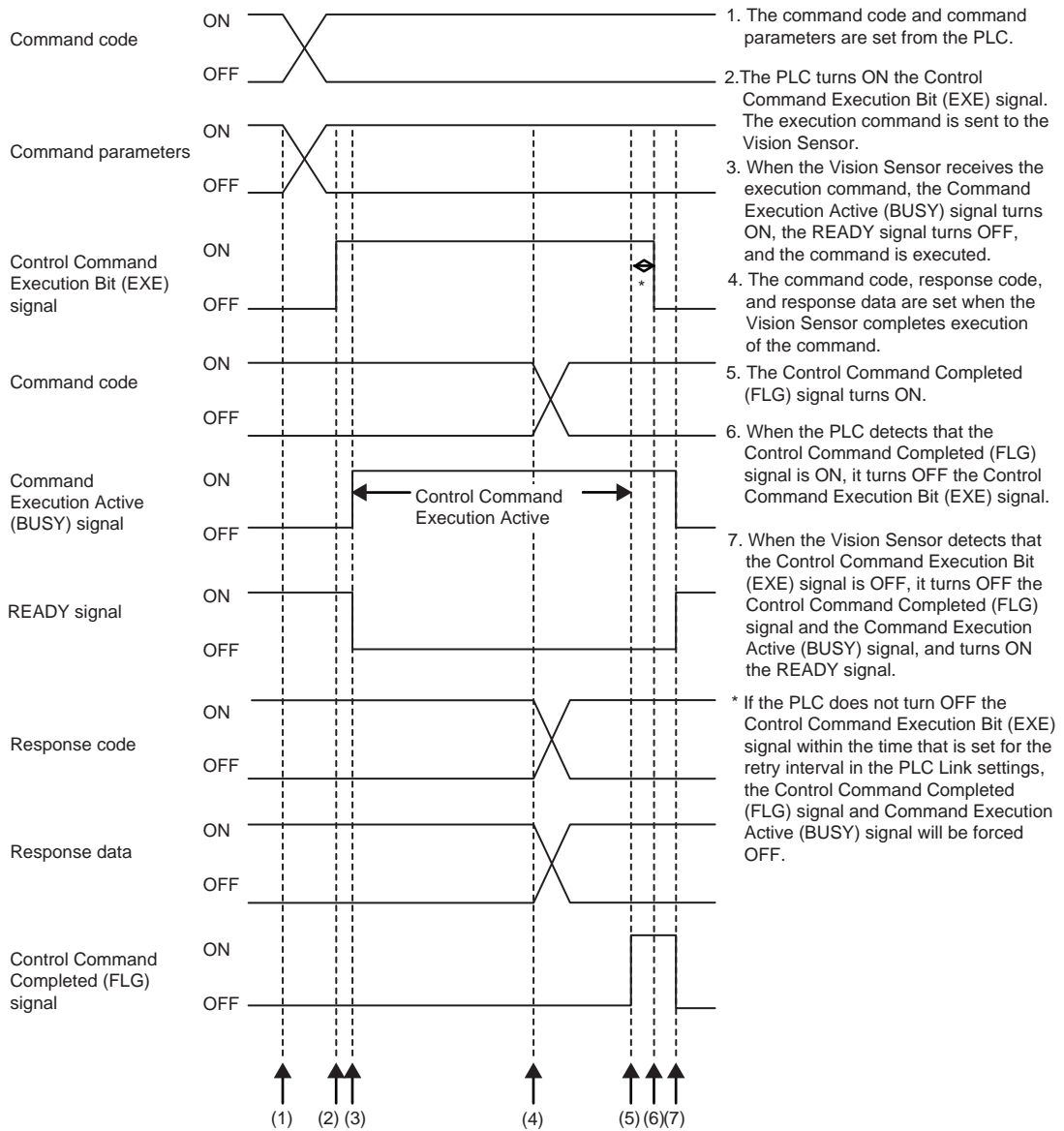

● Data Output after Measurements When Handshaking Is Enabled

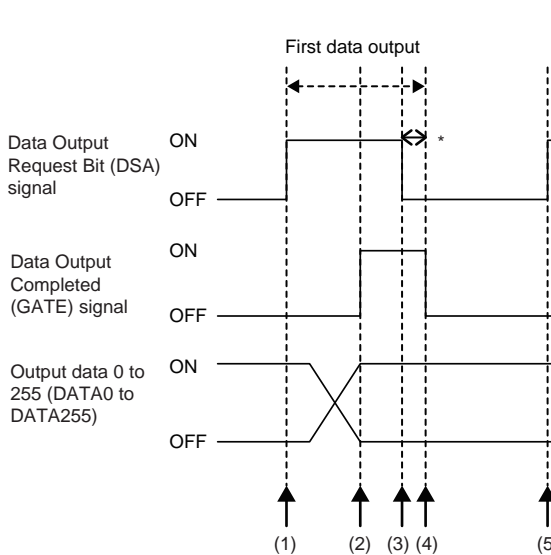

1. When the PLC is ready to receive output data, the Data Output Request Bit (DSA) is turned ON from the PLC and a request is made to the Vision Sensor to output the data.
2. The Vision Sensor outputs the data. After the data is output, the Data Output Completed (GATE) signal turns ON.
3. The PLC confirms that the Data Output Completed (GATE) signal has turned ON, loads the data, and turns OFF the Data Output Request Bit (DSA) signal.
4. When the Vision Sensor detects that the Data Output Request (DSA) signal is OFF, it automatically turns OFF the Data Output Completed (GATE) signal.
5. The Data Output Request Bit (DSA) signal is turned ON from the PLC and a request is made to output the following data.

\* If the Data Output Request Bit (DSA) signal is not turned OFF within the time that is set for the retry interval in the PLC Link settings, the Data Output Completed (GATE) signal is forced OFF and data output is completed.

● Data Output after Measurements When Handshaking Is Disabled

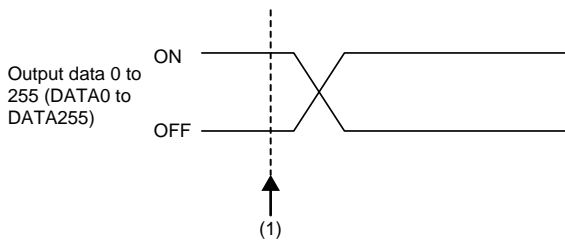

1. Data is output automatically when the Vision Sensor completes a measurement.
- \* The PLC turns ON the Control Command Completed (FLG) signal and then gets the output data.

## Sample Ladder Programming

### ● Command/Response Communications

The following sample program is used to perform single measurements. The single measurements command (lower bytes: #1010, upper bytes: #0010) is sent to the Vision Sensor.

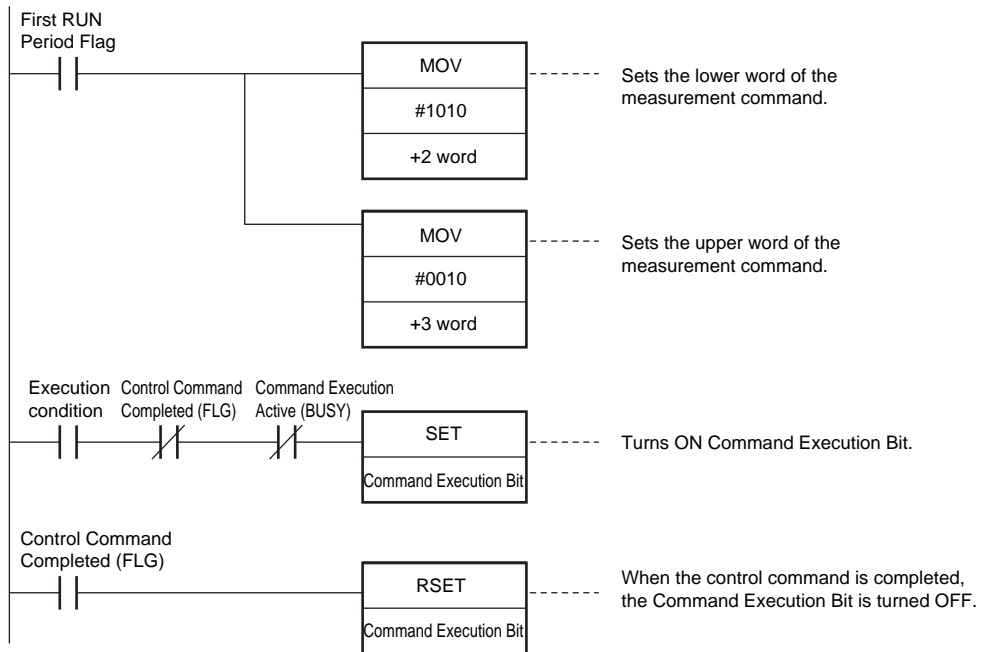

### Important

Create the ladder program to control the TRIG signal so that it does not turn ON while the BUSY signal is ON. If not, a TRIG input error will occur and the ERROR signal will turn ON.

### Note

You can combine both parallel and PLC Link communications. PLC Link commands cannot be executed while the Command Execution Active (BUSY) parallel communications signal is ON during execution for the parallel measurement trigger input (TRIG signal). Execute PLC Link commands while the Command Execution Active (BUSY) parallel communications signal is OFF. You can also perform measurements with the measurement trigger input (TRIG signal) in parallel I/O and use PLC Link communications to output data.

### ● Data Output after Measurements When Handshaking Is Enabled

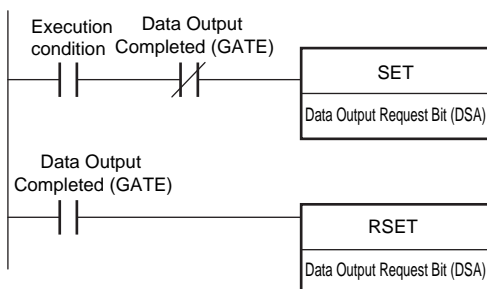

## 9-4 Controlling Operation and Outputting Data with TCP No-protocol Communications

You can use no-protocol communications between an external device (such as a PLC) and the Vision Sensor to perform control from the external device via command/response communications or to output data after measurements. You can use these communications methods simultaneously.

### ● Command/Response Communications

With no-protocol communications, the external device sends a control command to the Vision Sensor and receives a response back from the Vision Sensor. This allows you to control the operation of the Vision Sensor (e.g., perform single measurements or change the scene).

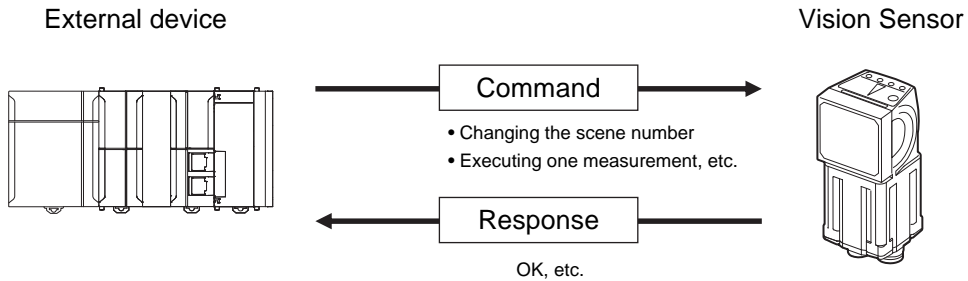

The external device sends a command as an ASCII string (e.g., "MEASURE" for a single measurement). The Vision Sensor then returns a response such as "OK", "NG", or some value.

### ● Data Output after Measurements

Immediately after a single or continuous measurement, the Vision Sensor will automatically output to an external device (e.g., a PLC) the data for measurements that are specified for output in advance. This enables you to easily transfer the measurement results data for inspection items to the external device.

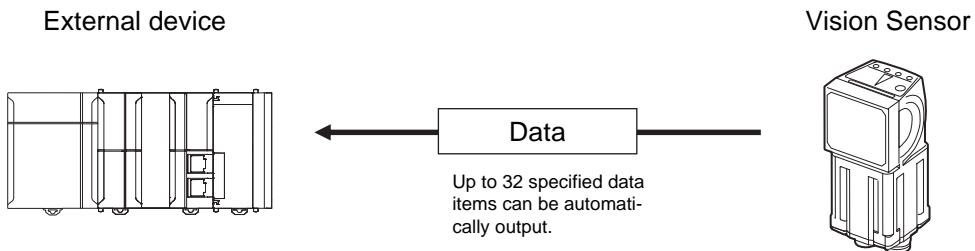

You must specify in advance the data to output (up to 32 items) after measurements. That data is sent to the external device in either ASCII or binary format through a continuous serial connection. There is no handshaking from the external device to confirm if it can receive the data.

## Setting Up No-protocol Communications

### Setting Network Settings in the Sensor

This section describes how to set the IP address and other network settings in the Vision Sensor. Refer to the following section for details.

 2-5 Setting Up Ethernet: p. 53

### Initial Settings for No-protocol Communications

You must set the communications method of the destination external device to perform no-protocol communications.

#### ► [Sensor settings] – [Data output] – [No-protocol data]

- 1 Press [No protocol (TCP)].
- 2 Set [Connection mode] to either [TCP server] or [TCP client]. When you are finished, press [Back].
- 3 If you set [Connection mode] to [TCP client], set the following parameters.

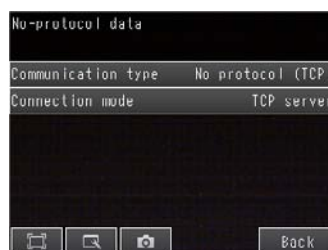

Item	Description	Setting range
IP address	<p>Set the IP address of the external device at the connection destination. Set it in the form a.b.c.d.</p> <p><b>Note</b></p> <p>If you connect an external OMRON CS/ CJseries PLC to Ethernet, the following default IP address is assigned to the PLC.</p> <ul style="list-style-type: none"><li>• IP address: 192.168.250.node_address</li></ul>	<p>a: 1 to 253, b: 0 to 255, c: 0 to 255, d: 0 to 255 Default: 10.5.5.1</p>
Port No.	<p>Set the I/O port number of the external device at the connection destination. Set the value to between 0 and 65,535.</p>	<p>0 to 65,535 Default: 9,600</p>

#### Important

If the [Connection mode] parameter is set to [TCP server] for TCP no-protocol communications, the port number of the Sensor will always be 9876 for TCP no-protocol communications.

## Setting the Data To Output Automatically after Measurements

You can set the data to output automatically after measurements. (You can set up to 32 data items.)

### Data That Can Be Output

You can output up to 32 data items (data 0 to data 31).

The measurement data from inspection items that can be output and the calculation results from the expression settings can be output. For data that can be output, refer to the *Measurement Data That Can Be Used for External Outputs and Calculations* for each inspection item.

### Assigning Inspection Results to Output Data

You can individually assign the parameters of the inspection items to output data (data 0 to data 31).

The following procedure shows how to assign the measured position X of [0. Search] to data 0 for a binary output.

#### ► [In/Out] – [I/O setting] – [Output data setting] – [Link data output] – [Output data set]

- 1 Press [0. Data 0].
- 2 Press [Data setting].
- 3 Press [I0. Search].
- 4 Press [Position X X].

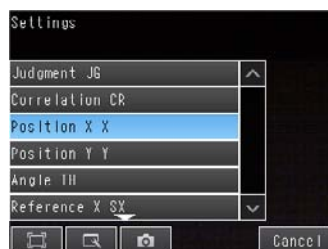

- 5 If the inspection item allows multi-point output, press the number ([0] to [30]) of the inspection result for which to output the data from the list of inspection results.

To register something to data 1 and higher, repeat this process.

The settings will be enabled after you restart the Sensor.

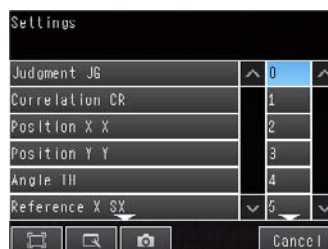

## Assigning More Than One Inspection Result to the Same Output Data

You can assign more than one inspection result to the same data output to output all of the assigned results. This is possible for the following inspection results.

- Parameters for the same inspection item: You can assign up to five inspection results.
- Inspection results that support multi-point output: You can assign inspection results within the specified range (0 to 31).

The following procedure shows how to assign more than one inspection result to data 0.

### ► [In/Out] – [I/O setting] – [Output data setting] – [Link data output] – [Output data set]

- 1 Press [0. Data 0].
- 2 Press [Multi-data].
- 3 Set the following items on the display to set expressions.



Item	Description
Expression	Register the expression to use to output multiple data. Examples: LPR (0, 3, I0.X, I0.Y) LPC (0, I0.C, I0.X, I0.Y)
Const.	Used to insert numbers and symbols into the expression.
Data	Used to select the inspection items for which to output data and insert the parameters to output into the expression. Example: Selecting Parameters for the Search Item at Inspection Item 0 Inspection item: I0. Search Judgement result: Judgement JG, Correlation: Corre. CR
Math.	Either of the following two functions can be inserted. <ul style="list-style-type: none"> <li>• LPR function (order of the measurement data) The measurement data is output in order. Format: LPR(start_number,number_of_data,data_1, data_2,...data_5) You can omit data 2 to data 5.</li> <li>• LPC function (order of the detection points) Data is output for each detected measurement point. Format: LPC(start_number,number_of_data,data_1, data_2,...data_5) You can omit data 2 to data 5.</li> </ul>

**To register something to data 1 and higher, repeat this process.  
The settings will be enabled after you restart the Sensor.**

● Expression Setting Example

This example registers an expression to output the following inspection results for data 0.

Inspection item: 0 Search

Parameters to output: Position X, Position Y, Reference SX, and Reference SY

Multi-point output setting: Multi-point output Check Box selected, Count = 4

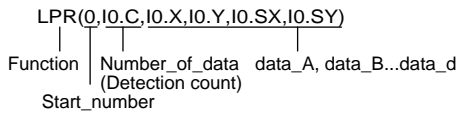

Output Results

The data for 16 items (64 bytes) is output in the following order for the expression that is registered for data 0.

Output order <sup>*1</sup>	Assigned data
1	I0.X[0] (Position X 1st point)
2	I0.Y[0] (Position Y 1st point)
3	I0.SX[0] (Reference SX 1st point)
4	I0.SY[0] (Reference SY 1st point)
5	I0.X[1] (Position X 2nd point)
6	I0.Y[1] (Position Y 2nd point)
7	I0.SX[1] (Reference SX 2nd point)
8	I0.SY[1] (Reference SY 2nd point)
9	I0.X[2] (Position X 3rd point)
10	I0.Y[2] (Position Y 3rd point)
11	I0.SX[2] (Reference SX 3rd point)
12	I0.SY[2] (Reference SY 3rd point)
13	I0.X[3] (Position X 4th point)
14	I0.Y[3] (Position Y 4th point)
15	I0.SX[3] (Reference SX 4th point)
16	I0.SY[3] (Reference SY 4th point)

\*1 The inspection results will be output according to the sorting method that is set for multi-point output for the inspection item.



## Setting the Output Format

### ► [In/Out] – [I/O setting] – [Output data setting] – [Noprotocol data output]

- 1 Press [Output format].
- 2 Set [Output form] to [ASCII] or [Binary].
- 3 Set the data format for the data form that you selected.

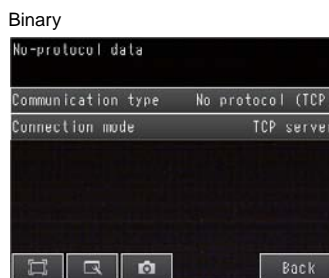
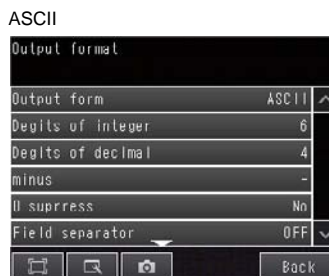

Item		Description	Setting range
For ASCII	Digits of integer	Sets the number of digits in the integer part of the number.	1 to 10 digits Default: 6 digits
	Digits of decimal	Set the number of digits in the integer part.	0 to 4 digits Default: 4 digits
	Negative	Sets the way to express negative numbers.	– or 8 Default: –
	0 Suppressed	Sets whether to use zero suppression.	Yes or No Default: No
	Field separator	Sets the field separator.	OFF, comma, tab, space, CR, LF, or CR+LF Default: OFF
	Record separator	Sets the record separator.	OFF, comma, tab, space, CR, LF, or CR+LF Default: OFF
For Binary	Decimal output form	Set the decimal output form for numerical data.	Floating point or fixed point (default: Fixed point)

• **When Output Format Is ASCII**

Set the parameters for integer digits, decimal digits, negative numbers, 0 suppression, the field separator, and the record separator.

• **Output Format**

Measured value of data 0	,	Measured value of data 1	,	...	Measured value of data 7	CR
--------------------------	---	--------------------------	---	-----	--------------------------	----

**Note**

The data output method, digits, and data separators can be changed as needed.

Example: Integer digits: 5, decimal digits: 3, negative number expression: -, zero suppressed: none, field separator: comma, record separator: CR

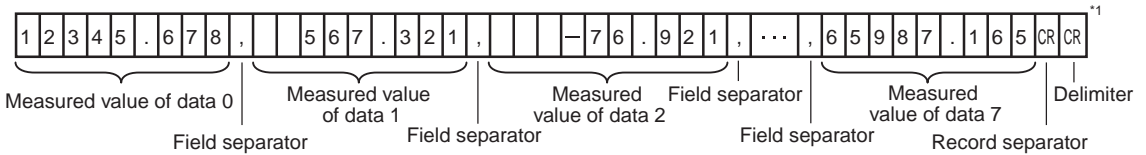

\*1 Because the record separator is set to CR, only one record is output for each measurement. A blank line (CR: delimiter) will therefore be entered after the record separator. If you do not want a blank line, set the record separator to None.

**Note**

The field separator is not output unless the data continues.

The following range of values can be output.

$$-999,999,999.9999 \leq \text{Measured value} \leq 999,999,999.9999$$

If the measured value is lower than -999,999,999.9999, then -999,999,999.9999 is output.

If the measured value is higher than 999,999,999.9999, then 999,999,999.9999 is output.

The following values are output if JG (Judge) is set.

OK: 0

NG: -1

**Note**

Data that is output after measurement is output until the last data even after the measurement is finished. Data output is not interrupted midway.

• **When Output Format Is Binary**

Set the numerical expression.

Select either fixed decimal or floating-point decimal.

• **Output Format**

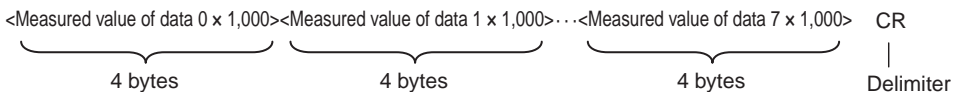

The measurement data multiplied by 1,000 is output continuously at 4 bytes per data. Negative numbers are output as two's complements.

Example: When Data 0 is 256.324 and Data 1 is -1.000.

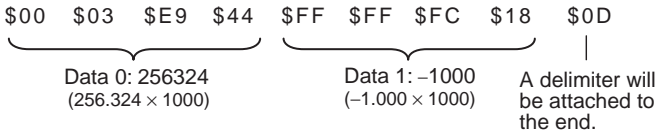

**Note**

Binary output does not use data separators, i.e., field separators or record separators. These separators are used only for ASCII output.

The following range of values can be output.

$$-2,147,483.648 \leq \text{Measured value} \leq 2,147,483.647$$

If the measured value is lower than -2,147,483.648, then -2,147,483.648 is output.

If the measured value is higher than 2,147,483.647, then 2,147,483.647 is output.

The following values are output if JG (Judge) is set.

OK: 0 (0 × 1000)

NG: -1000 (-1 × 1000)

**Note**

Data that is output after measurement is output until the last data even after the measurement is finished. Data output is not interrupted midway.

**Controlling the Sensor from an External Device (Procedure for No-protocol Command/Response Communications)**

**Command Format**

This section describes the command format for no-protocol communications.

Commands defined in the command list can be used.

Set commands and parameters in ASCII.

If the command has an argument parameter, set the parameter after inserting a space (0x20).

If it has multiple parameters, insert a space before each parameter.

Place a delimiter at the end of the command. No space is required before the delimiter.

The delimiter is always CR.

<Command Format>

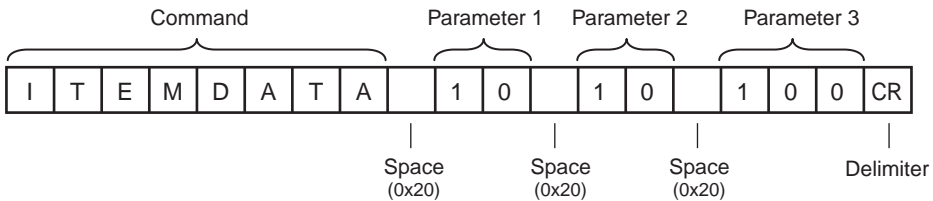

### <Response Format>

If a parameter is attached, the parameter and delimiter are output when the command is processed normally, and the command execution result is OK. A delimiter is inserted at the end of the response.

The delimiter is always CR.

### Command Execution Result

#### Parameter

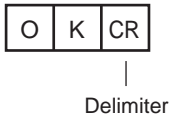
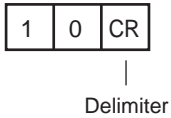

If the command is not processed normally, the command execution result is NG.

#### Command Execution Result

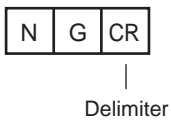

An error occurs in the following cases.

- A non-existent command was specified.
- The number of parameters is incorrect.
- The parameter range is incorrect.
- The parameter content is incorrect.
- Operation could not be performed normally for the operation command.

## Command List

The following table lists the no-protocol commands.

Commands that can be used in no-protocol Ethernet communications are listed below.

Type of command	Command	Abbreviation	Function	Reference
Measurement control and measurement acquisition commands	MEASURE	M	Executes one measurement.	p. 360
	MEASURE /C	M /C	Starts continuous measurements.	p. 361
	MEASURE /E	M /E	Ends continuous measurements.	p. 362
Utility commands	CLRMEAS	None	Clears the measurement values.	p. 363
	CLRERR	None	Clears the error output status (error signal and error indicator).	p. 364
	DATASAVE	None	Saves the settings data to the Sensor.	p. 364
	MODEL	None	Re-registers the models for registered Search inspection items.	p. 365
	RESET	None	Restarts the Sensor.	p. 365
	TEACH	None	Executes teaching for all applicable inspection items.	p. 366
Scene control commands	SCENE	S	Acquires the current scene number.	p. 366
	SCENE <i>Scene_number</i>	S <i>Scene_number</i>	Changes the scene number being used.	p. 367
Data acquisition/setting commands	POSITIONDATA <i>Item_number</i> <i>External_reference_data_number</i>	PD <i>Item_number</i> <i>External_reference_data_number</i>	Acquires data from a position compensation item or filter item.	p. 368
	POSITIONDATA <i>Item_number</i> <i>External_reference_data_number</i> <i>Setting</i>	PD <i>Item_number</i> <i>External_reference_data_number</i> <i>Setting</i>	Sets data for a position compensation item or filter item.	p. 368
	ITEMDATA <i>Inspection_item_number</i> <i>External_reference_data_number</i>	ID <i>Inspection_item_number</i> <i>External_reference_data_number</i>	Acquires the inspection item data.	p. 370
	ITEMDATA <i>Inspection_item_number</i> <i>External_reference_data_number</i> <i>Set_value</i>	ID <i>Inspection_item_number</i> <i>External_reference_data_number</i> <i>Set_value</i>	Sets the inspection item data.	p. 371
	VERGET/S	None	Acquires the version information of the Sensor software.	p. 372
	VERGET/H	None	Acquires the Sensor model information.	p. 373
	ERRGET	None	Acquires the latest error code of the Sensor.	p. 374

## Command Details

### Measurement Control and Measurement Acquisition Commands

#### ● MEASURE or M

##### Execute Measurement

This command executes one measurement.

If data output is not set, only the measurement is performed.

If data output is set, the measurement is performed and the result is returned as response data.

##### <Command Format>

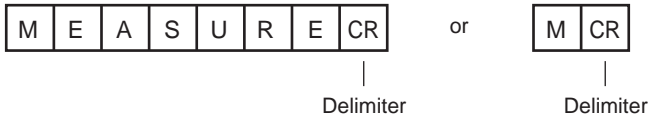

##### <Response Format>

When the Command Is Processed Normally

O	K	CR
---	---	----

Measurement result	CR
-----------------------	----

|  
Delimiter

When the Command Is Not Processed Normally

E	R	CR
---	---	----

|  
Delimiter

##### <Parameter Descriptions>

Measurement result	The measurement result is output as the response when data output is set. The measurement result is not output when data output is not set. Setting the Data To Output Automatically after Measurements: p. 352
--------------------	---

### Start Continuous Measurements

This command starts continuous measurements.

If data output is not set, only continuous measurement is performed.

If data output is set, continuous measurement is performed and the results corresponding to the number of measurements made are returned as response data.

#### <Command Format>

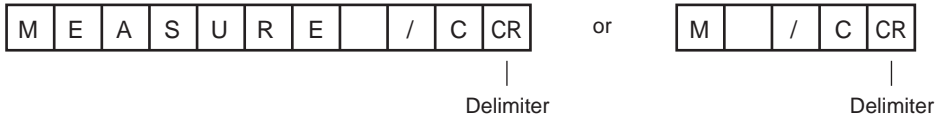

#### <Response Format>

When the Command Is Processed Normally

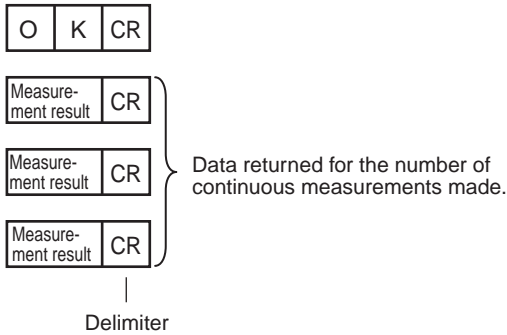

When the Command Is Not Processed Normally

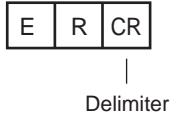

#### <Parameter Descriptions>

Measurement result	<p>The measurement results corresponding to the number of measurements made are output when data output is set.</p> <p>The measurement result is not output when data output is not set.</p> <p> Setting the Data To Output Automatically after Measurements: p. 352</p>
--------------------	---

### End Continuous Measurements

The command ends continuous measurements.

#### <Command Format>

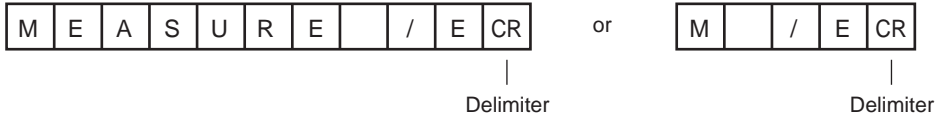

#### <Response Format>

When the Command Is Processed Normally

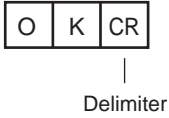

When the Command Is Not Processed Normally

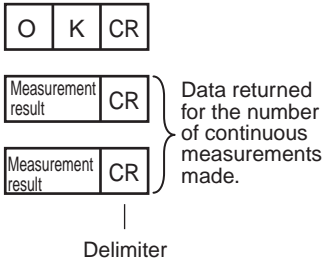

#### Note

Set the data output to output measurement results.  
If data output is not set, only the command response is output.

 Setting the Data To Output Automatically after Measurements: p. 352



## Utility commands

### ● CLRMEAS

#### Clear Measurement Values

This command clears the measurement values.

<Command Format>

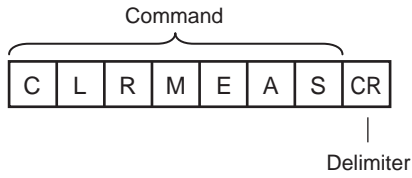

<Response Format>

When the Command Is Processed Normally

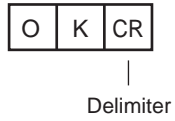

When the Command Is Not Processed Normally

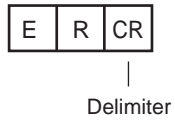

● CLRERR

Clear Errors

This command clears the error output status (error output and error indicator).

<Command Format>

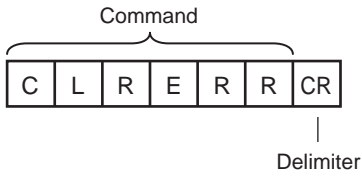

<Response Format>

When the Command Is Processed Normally

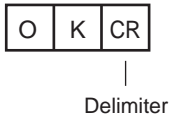

When the Command Is Not Processed Normally

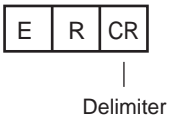

● DATASAVE

Save Settings

This command saves the current system data and scene groups to the Sensor.

<Command Format>

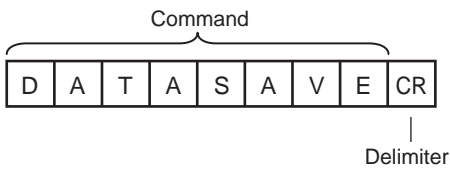

<Response Format>

When the Command Is Processed Normally

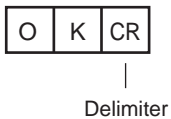

When the Command Is Not Processed Normally

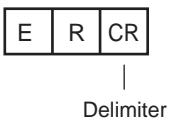

● MODEL

Re-register Models

This command re-registers the models for registered Search and Color Data inspection items.

<Command Format>

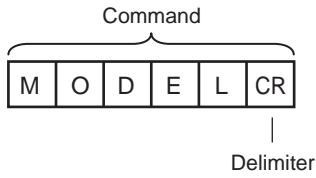

<Response Format>

When the Command Is Processed Normally

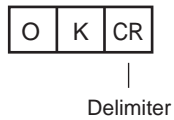

When the Command Is Not Processed Normally

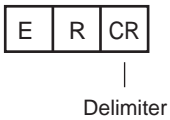

● RESET

Resets the Sensor

This command resets the Sensor.

<Command Format>

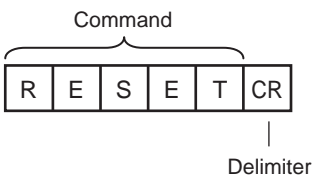

<Response Format>

When the Command Is Processed Normally

If process is completed normally, the Sensor is restarted. There is therefore no response.

When the Command Is Not Processed Normally

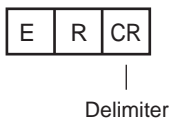

● TEACH

Perform Teaching

This command performs teaching for all of the registered inspection items.

<Command Format>

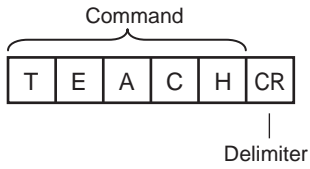

<Response Format>

When the Command Is Processed Normally

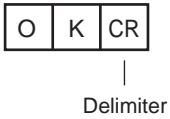

When the Command Is Not Processed Normally

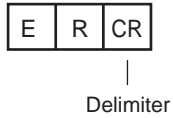

**Scene Control Commands**

● SCENE or S

Acquire Scene Number

This command acquires the scene number currently being used.

<Command Format>

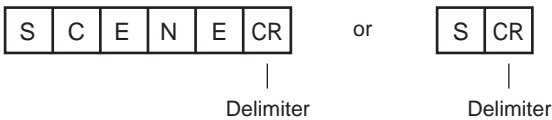

<Response Format>

When the Command Is Processed Normally

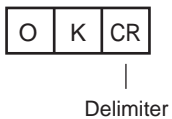
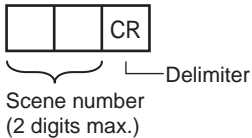

When the Command Is Not Processed Normally

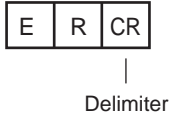

<Parameter Descriptions>

Scene number	The acquired scene number (currently used scene number) is returned.
--------------	--

Example:

When Scene 0 Is Being Used

<Command>



<Response>

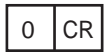

Change Scene Number

This command changes the scene number to use.

<Command Format>

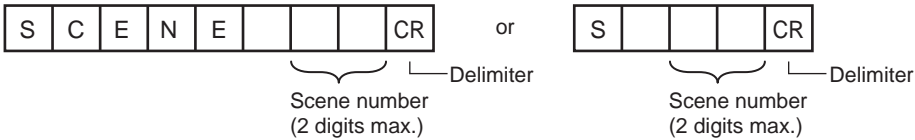

<Response Format>

When the Command Is Processed Normally

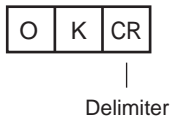

When the Command Is Not Processed Normally

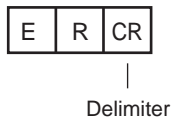

<Parameter Descriptions>

Scene number	Specifies the scene number (0 to 31) to change to.
--------------	--

## Data Acquisition/Setting Commands

### ● POSITIONDATA or PD

#### Get Image Adjustment Data

This command acquires parameters or measurement values from a position compensation item or filter item.

#### <Command Format>

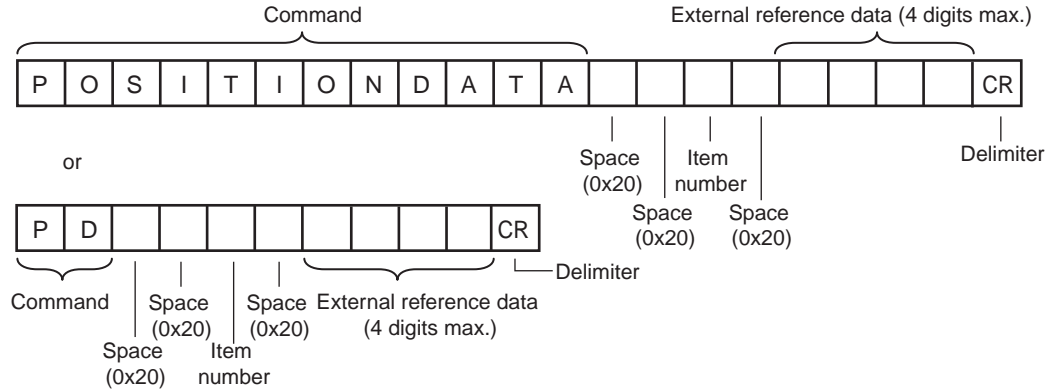

#### <Response Format>

When the Command Is Processed Normally

Acquired value CR

OK CR

Delimiter

When the Command Is Not Processed Normally

ER CR

Delimiter

#### <Parameter Descriptions>

Inspection item number	Specifies the item number of the position compensation item or of the filter item.
External reference data number	Specifies the external reference data number. 12-2 External Reference Parameters: p. 430
Acquired value	Returns the image adjustment data or threshold value. 12-2 External Reference Parameters: p. 430

## Set Image Adjustment Data

This command sets parameters or measurement values from a position compensation item or filter item.

### <Command Format>

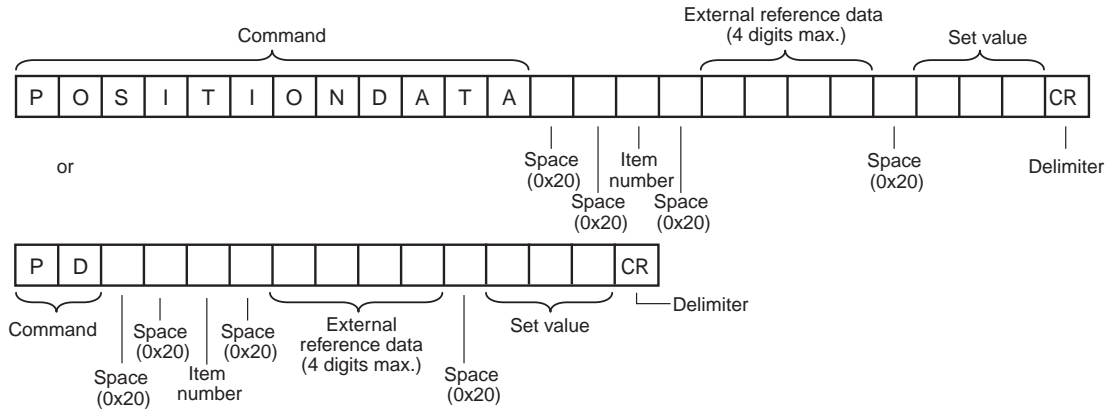

### <Response Format>

When the Command Is Processed Normally

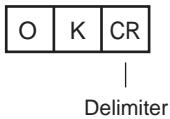

When the Command Is Not Processed Normally

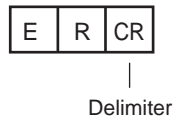

### <Parameter Descriptions>

Inspection item number	Specifies the item number of the position compensation item or of the filter item.
External reference data number	Specifies the external reference data number. 12-2 External Reference Parameters: p. 430
Set value	Specifies the set value. 12-2 External Reference Parameters: p. 430

● ITEMDATA or ID

Acquire Inspection Item Data

This command acquires the parameters and measurement values of the specified inspection item.

<Command Format>

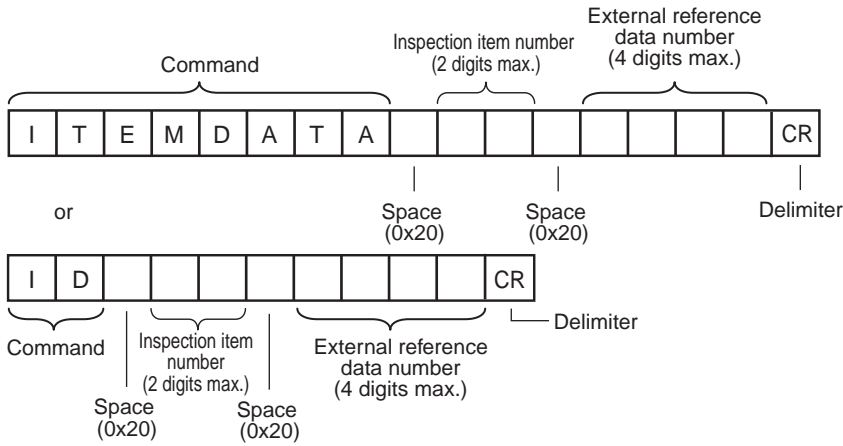

<Response Format>

When the Command Is Processed Normally





Delimiter

When the Command Is Not Processed Normally



Delimiter

<Parameter Descriptions>

Inspection item number	Specifies the inspection item number. (0 to 31)
External reference data number	Specifies the external reference data number. (0 to 9999)  12-2 External Reference Parameters: p. 430
Acquired value	Returns the data for the specified inspection item.  12-2 External Reference Parameters: p. 430



### Set Inspection Item Data

This command sets the parameters and measurement values of the specified inspection item.

#### <Command Format>

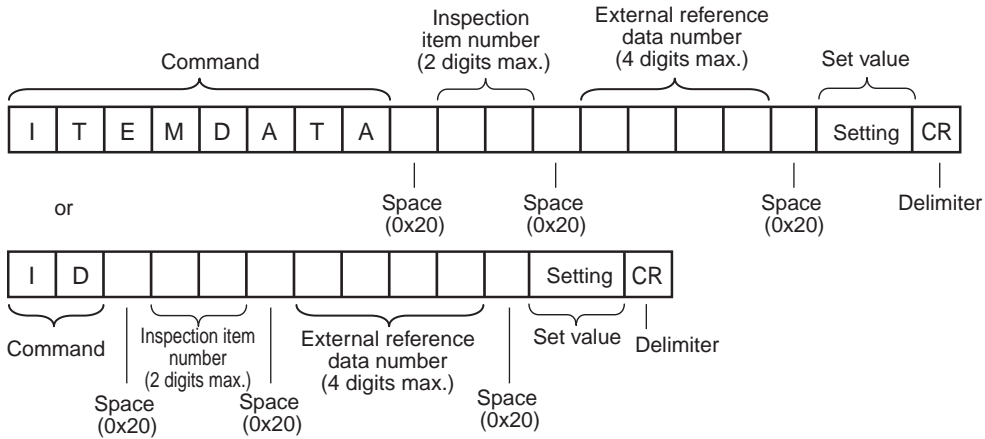

#### <Response Format>

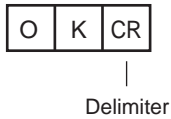

When the Command Is Processed Normally

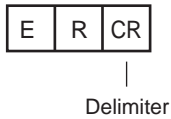

When the Command Is Not Processed Normally



#### <Parameter Descriptions>

Inspection item number	Specifies the inspection item number. (0 to 31)
External reference data number	Specifies the external reference data number. (0 to 9999)  12-2 External Reference Parameters: p. 430
Acquired value	Returns the data for the specified inspection item.  12-2 External Reference Parameters: p. 430

● VERGET

Acquire Software Version

This command acquires the version information of the Sensor software.

<Command Format>

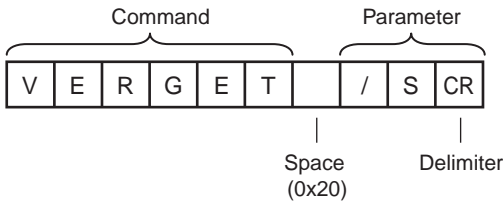

<Response Format>

When the Command Is Processed Normally

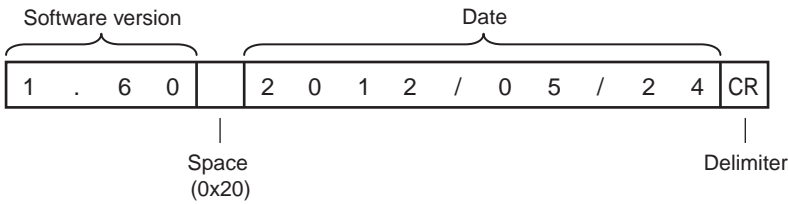

|  
Delimiter

When the Command Is Not Processed Normally



|  
Delimiter

<Parameter Descriptions>

Software version	Returns the software version. Example: When the software version is 1.60, the response is 1.60.
Date	Returns the date. Example: When the date is 13 May 2012, the response is 2012/05/13.

### Acquire Sensor Model

This command acquires the Sensor model.

#### <Command Format>

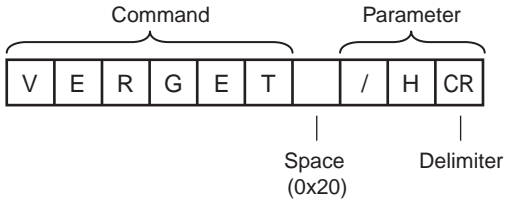

#### <Response Format>

When the Command Is Processed Normally

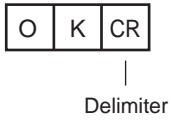
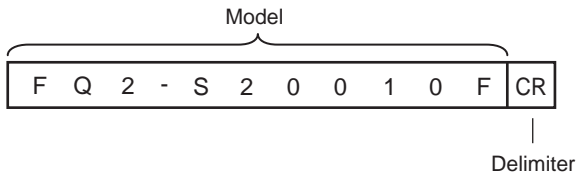

When the Command Is Not Processed Normally

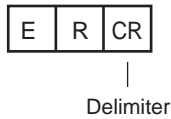

#### <Parameter Descriptions>

Model	Returns the model. Example: When the model is FQ2-S20010F, the response is FQ2-S20010F.
-------	--

● ERRGET

Acquire Error Information

This command acquires the latest error code from the Sensor.

<Command Format>

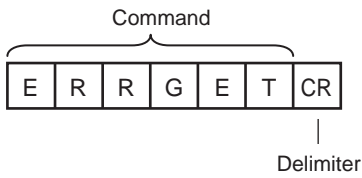

<Response Format>

When the Command Is Processed Normally

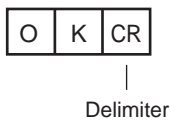
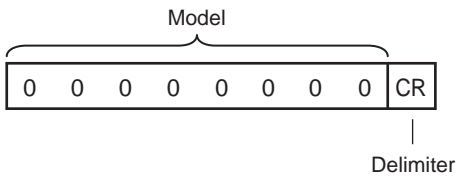

When the Command Is Not Processed Normally

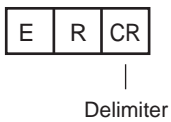

<Parameter Descriptions>

Error code	Returns the latest error code. If there is no error history, the response is 00000000.  11-1 Error Histories: p. 398
------------	--

### Communications Example

An example of the communications log when a computer is connected and communications is performed with a no-protocol command from a terminal application is shown below.

Example 1: Changing Scenes (Scene number 1 is specified.)

```
S_1 _____ Single-byte space
OK
```

Example 2: Acquiring inspection item data (Acquires the judgement result for a search registered to inspection item 10.)

```
ITEMDATA_100 _____ Single-byte space
0
OK
```

Example 3: Measurement when Data Output Is Not Set

```
M
OK
```

Example 4: Measurement when Data Output Is Set

```
M
OK
    1.0000      0.0000      0.0000      306.0000
M
OK
    2.0000      0.0000      0.0000      0.0000
```

## Introduction to FINS Commands

FINS is a communications command system for a message service that is commonly used on OMRON networks.

Data can be sent and received and various controls, such as changing the operating mode, setting/resetting bits, and file operations, can be performed when necessary.

For details on FINS command specifications, the commands that are sent from a CPU Unit, and other information, refer to the *SYSMAC CS/CJ/CP/NSJ Series Communications Commands Reference Manual* (Cat. No. W342).

## Range for Receiving FINS Commands

The FQ2 can receive FINS commands that are sent by an OMRON CPU Unit on the same Ethernet network. The FQ2 can send responses to the received commands to the CPU Unit that sent the commands. The FQ2 cannot receive FINS commands from any networks other than Ethernet or from devices on networks to which the FQ2 is not directly connected.

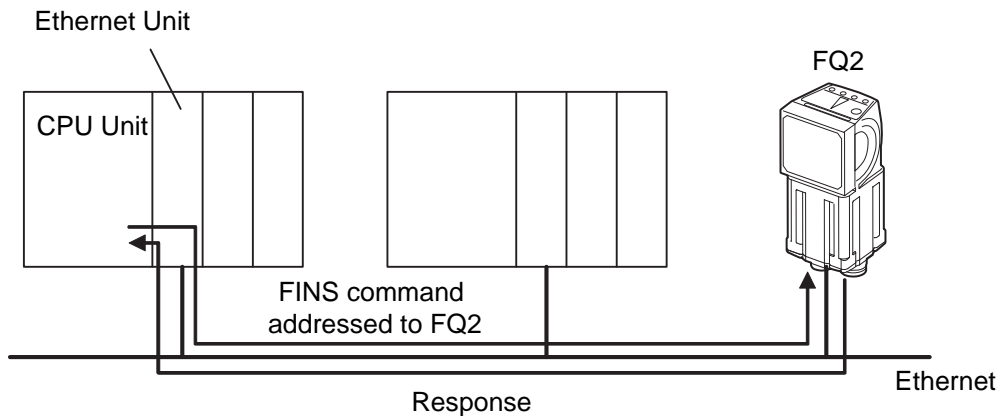

## Sending FINS Commands

A special instruction for sending commands, the CMND instruction, is used to send FINS commands from the CPU Unit.

If you specify the FINS command code to send in the CMND instruction, the CPU Unit will attach the FINS header and send the FINS command frame.

When the CPU Unit receives the response from the Sensor, it automatically removes the FINS header and stores only the response data in the memory location that is specified in the CMND instruction.

Refer to the *SYSMAC CS/CJ/CP/NSJ Series Communications Commands Reference Manual* (Cat. No. W342) for more information on sending FINS commands with the CMND instruction.

● **Setting the Destination in the CMND Instruction**

To send a FINS command to the FQ2, the destination of the FINS command is specified in the control data of the CMND instruction.

Control data item	Setting
Destination network address	00 hex: Local network (The FINS commands must be sent to the local network.)
Destination node address	Specify the last two digits of the IP address of the FQ2.
Destination unit address	Always specify 00 hex.
Communications port number	Specify any communications port.
Serial port number	Always specify 00 hex.

● **Command Codes for the FQ2**

Command codes for the FQ2 consist of a 2-byte command code (which consists of an MRC and SRC) and a 4-byte Vision Sensor command code.

Example: Command Code for a Single Measurement Command

Command code		Vision Sensor command code (4 bytes)
MRC (1 byte)	SRC (1 byte)	
28	0F	00101010

## Setting Up Communications (FINS/TCP)

Communications are set up in the same way as for TCP no-protocol communications.

 Setting Up No-protocol Communications: p. 351

## List of FINS Commands

### Command List

The following table lists the FINS commands.

Commands that can be used in FINS Ethernet communications are listed below.

Type of command	Command codes (hex)		Function	Reference
	MRC+SRC command code	Vision Sensor command code		
Measurement control and measurement acquisition commands	280F	00101010	Executes one measurement.	p.379
Utility commands	280F	00102010	Clears the measurement values.	p.380
	280F	00102040	Clears the error output status (error signal and error indicator).	p.380
	280F	00103010	Saves the settings data to the Sensor.	p.381
	280F	00104010	Re-registers the models for registered Search and Color Data inspection items.	p.381
	280F	0010F010	Restarts the Sensor.	p.382
	280F	00104020	Executes teaching for all applicable inspection items.	p.382
Scene control commands	280F	00201000	Acquires the current scene number.	p.383
	280F	00301000	Changes the scene number being used.	p.384
Data acquisition/setting commands	280F	00401010	Acquires image adjustment data	p.385
	280F	00501010	Sets image adjustment data.	p.386
	280F	00401020	Acquires the inspection item data.	p.387
	280F	00501020	Sets the inspection item data.	p.388
	280F	00403000	Acquires the version information of the Sensor software.	p.389
	280F	00205000	Acquires the latest error code of the Sensor.	p.389



## FINS Command Details

### Executing Measurements: 28F 00101010

This command executes one measurement.

If Ethernet output is not set, only the measurement is performed.

If Ethernet output is set, the measurement is performed and the result is returned as response data.

#### ● Command Format

MRC (1 byte)	SRC (1 byte)	Vision Sensor command code (4 bytes)
28	0F	00101010

#### ● Response Format

MRC (1 byte)	SRC (1 byte)	MRES (1 byte)	SRES (1 byte)	Vision Sensor command code (4 bytes)	Measurement result (1,024 bytes)
28	0F	End code		00101010	Measurement result

#### ● End Codes

End code (hex)	Meaning
0000	Command execution ended normally.
FFFF	Command execution ended in an error.

#### ● Parameter Descriptions

Measurement result	<ul style="list-style-type: none"><li>Returns the measurement result as the response when data output is set. The measurement result is not output when data output is not set.<ul style="list-style-type: none"><li><input type="checkbox"/> Setting the Data To Output Automatically after Measurements: p. 379</li></ul></li><li>Each data item requires 4 bytes. Up to 1,024 bytes of data can be received.</li></ul>
--------------------	---

## Clearing Measurement Values: 280F 00102010

This command clears the measurement values.

### ● Command Format

MRC (1 byte)	SRC (1 byte)	Vision Sensor command code (4 bytes)
28	0F	00102010

### ● Response Format

MRC (1 byte)	SRC (1 byte)	MRES (1 byte)	SRES (1 byte)	Vision Sensor command code (4 bytes)
28	0F	End code		00102010

### ● End Codes

End code (hex)	Meaning
0000	Command execution ended normally.
FFFF	Command execution ended in an error.

## Clearing Errors: 280F 00102040

This command clears the error output status (error output and error indicator).

### ● Format

MRC (1 byte)	SRC (1 byte)	Vision Sensor command code (4 bytes)
28	0F	00102040

### ● Response Format

MRC (1 byte)	SRC (1 byte)	MRES (1 byte)	SRES (1 byte)	Vision Sensor command code (4 bytes)
28	0F	End code		00102040

### ● End Codes

End code (hex)	Meaning
0000	Command execution ended normally.
FFFF	Command execution ended in an error.

## Saving Data in the Sensor: 280F 00103010

This command saves the current setting data (system data, scene groups, and calibration data) in the Sensor.

### ● Format

MRC (1 byte)	SRC (1 byte)	Vision Sensor command code (4 bytes)
28	0F	00103010

### ● Response Format

MRC (1 byte)	SRC (1 byte)	MRES (1 byte)	SRES (1 byte)	Vision Sensor command code (4 bytes)
28	0F	End code		00103010

### ● End Codes

End code (hex)	Meaning
0000	Command execution ended normally.
FFFF	Command execution ended in an error.

## Re-registering Models: 280F 00104010

This command re-registers the models for registered Search and Color Data inspection items.

### ● Format

MRC (1 byte)	SRC (1 byte)	Vision Sensor command code (4 bytes)
28	0F	00104010

### ● Response Format

MRC (1 byte)	SRC (1 byte)	MRES (1 byte)	SRES (1 byte)	Vision Sensor command code (4 bytes)
28	0F	End code		00104010

### ● End Codes

End code (hex)	Meaning
0000	Command execution ended normally.
FFFF	Command execution ended in an error.

## Resetting the Sensor: 280F 0010F010

This command resets the Sensor.

### ● Format

MRC (1 byte)	SRC (1 byte)	Vision Sensor command code (4 bytes)
28	0F	0010F010

### ● Response Format

If process is completed normally, the Sensor is reset. There is therefore no response.

## External Teaching: 280F 00104020

This command performs teaching for all applicable inspection items.

### ● Format

MRC (1 byte)	SRC (1 byte)	Vision Sensor command code (4 bytes)
28	0F	00104020

### ● Response Format

MRC (1 byte)	SRC (1 byte)	MRES (1 byte)	SRES (1 byte)	Vision Sensor command code (4 bytes)
28	0F	End code		00104020

### ● End Codes

End code (hex)	Meaning
0000	Command execution ended normally.
FFFF	Command execution ended in an error.

## Getting the Scene Number: 280F 00201000

This command acquires the scene number that is currently being used.

### ● Format

MRC (1 byte)	SRC (1 byte)	Vision Sensor command code (4 bytes)
28	0F	00201000

### ● Response Format

MRC (1 byte)	SRC (1 byte)	MRES (1 byte)	SRES (1 byte)	Vision Sensor command code (4 bytes)	Scene number (4 bytes)
28	0F	End code		00201000	Scene number that was acquired (2 digits max.)

### ● End Codes

End code (hex)	Meaning
0000	Command execution ended normally.
FFFF	Command execution ended in an error.

### ● Parameter Descriptions

Scene number	Returns the acquired scene number (the number of the current scene).
--------------	--

## Changing the Scene Number: 280F 00301000

This command changes the scene number to use.

### ● Format

MRC (1 byte)	SRC (1 byte)	Vision Sensor command code (4 bytes)	Scene number (4 bytes)
28	0F	00301000	Scene number to change to (2 digits max.)

### ● Response Format

MRC (1 byte)	SRC (1 byte)	MRES (1 byte)	SRES (1 byte)	Vision Sensor command code (4 bytes)
28	0F	End code		00301000

### ● End Codes

End code (hex)	Meaning
0000	Command execution ended normally.
FFFF	Command execution ended in an error.

### ● Parameter Descriptions

Scene number	Specifies the scene number (0 to 31) to change to.
--------------	--

## Get Image Adjustment Data: 280F 00401010

This command acquires parameters or measurement values from a position compensation item or filter item.

### ● Format

MRC (1 byte)	SRC (1 byte)	Vision Sensor command code (4 bytes)	Position compensation item/filter item number (4 bytes)	External reference number (4 bytes)
28	0F	00401010	Position compensation item/filter item number 0 to 7 (1 digit max.)	External reference number

### ● Response Format

MRC (1 byte)	SRC (1 byte)	MRES (1 byte)	SRES (1 byte)	Vision Sensor command code (4 bytes)	Acquired value (4 bytes)
28	0F	End code		00401010	Acquired value

### ● End Codes

End code (hex)	Meaning
0000	Command execution ended normally.
FFFF	Command execution ended in an error.

### ● Parameter Descriptions

Position compensation item number	Specifies the number of the position compensation item or filter item for which to acquire the data.
External reference number	Specifies the external reference number. <input type="checkbox"/> 12-2 External Reference Parameters: p. 430
Acquired value	Returns the image adjustment data or threshold value. <input type="checkbox"/> 12-2 External Reference Parameters: p. 430

## Set Image Adjustment Data: 280F 00501010

This command sets parameters or measurement values from a position compensation item or filter item.

### ● Format

MRC (1 byte)	SRC (1 byte)	Vision Sensor command code (4 bytes)	Position compensation item/filter item number (4 bytes)	External reference number (4 bytes)	Set value (4 bytes)
28	0F	00501010	Position compensation item/filter item number 0 to 7 (1 digit max.)	External reference number	Setting

### ● Response Format

MRC (1 byte)	SRC (1 byte)	MRES (1 byte)	SRES (1 byte)	Vision Sensor command code (4 bytes)
28	0F	End code		00501010

### ● End Codes

End code (hex)	Meaning
0000	Command execution ended normally.
FFFF	Command execution ended in an error.

### ● Parameter Descriptions

Position compensation item number	Specifies the number of the position compensation item or filter item to set.
External reference num- ber	Specifies the external reference number. <input type="checkbox"/> 12-2 External Reference Parameters: p. 430
Set value	Specifies the set value. <input type="checkbox"/> 12-2 External Reference Parameters: p. 430



## Getting the Inspection Item Data: 280F 00401020

This command acquires the parameters and measurement values of the specified inspection item.

### ● Format

MRC (1 byte)	SRC (1 byte)	Vision Sensor command code (4 bytes)	Inspection item number (4 bytes)	External reference number (4 bytes)
28	0F	00401020	Inspection item number from 00 to 1F (2 digits max.)	External reference number

### ● Response Format

MRC (1 byte)	SRC (1 byte)	MRES (1 byte)	SRES (1 byte)	Vision Sensor command code (4 bytes)	Acquired value (4 bytes)
28	0F	End code		00401020	Acquired value (1,000 times the actual value)

### ● End Codes

End code (hex)	Meaning
0000	Command execution ended normally.
FFFF	Command execution ended in an error.

### ● Parameter Descriptions

Inspection item number	Specifies the number of the inspection item for which to acquire the data.
External reference number	Specifies the external reference number. □ 12-2 External Reference Parameters: p. 430
Acquired value	Returns the data for the specified inspection item. □ 12-2 External Reference Parameters: p. 430

## Setting the Inspection Item Data: 280F 00501020

This command sets the parameters and measurement values of the specified inspection item.

### ● Format

MRC (1 byte)	SRC (1 byte)	Vision Sensor command code (4 bytes)	Inspection item number (4 bytes)	External reference number (4 bytes)	Set value (4 bytes)
28	0F	00501020	Inspection item number from 00 to 1F (2 digits max.)	External reference number	Set value (1,000 times the actual value)

### ● Response Format

MRC (1 byte)	SRC (1 byte)	MRES (1 byte)	SRES (1 byte)	Vision Sensor command code (4 bytes)
28	0F	End code		00501020

### ● End Codes

End code (hex)	Meaning
0000	Command execution ended normally.
FFFF	Command execution ended in an error.

### ● Parameter Descriptions

Inspection item number	Specifies the number of the inspection item to set.
External reference number	Specifies the external reference number. □□ 12-2 External Reference Parameters: p. 430
Setting	Specifies the set value. □□ 12-2 External Reference Parameters: p. 430

## Getting the Software Version: 280F 00403000

This command acquires the version information of the Sensor software.

### ● Format

MRC (1 byte)	SRC (1 byte)	Vision Sensor command code (4 bytes)
28	0F	00403000

### ● Response Format

MRC (1 byte)	SRC (1 byte)	MRES (1 byte)	SRES (1 byte)	Vision Sensor command code (4 bytes)	Software version text string (4 bytes)
28	0F	End code		00403000	Software version (1,000 times the actual value)

### ● End Codes

End code (hex)	Meaning
0000	Command execution ended normally.
FFFF	Command execution ended in an error.

### ● Parameter Descriptions

Software version text string	Returns the software version. Example: When the software version is 1.20, the response is 1200 (4B0 hex).
------------------------------	--

## Getting the Error Information: 280F 00205000

This command acquires the latest error code from the Sensor.

### ● Format

MRC (1 byte)	SRC (1 byte)	Vision Sensor command code (4 bytes)
28	0F	00205000

### ● Response Format

MRC (1 byte)	SRC (1 byte)	MRES (1 byte)	SRES (1 byte)	Vision Sensor command code (4 bytes)	Error code (4 bytes)
28	0F	End code		00205000	Error code

### ● Parameter Descriptions

Error code	Returns the latest error code. If there is no error record, the response is 00000000. <input type="checkbox"/> 11-1 Error Histories: p. 398
------------	---

MEMO

# Connecting with RS-232C

---

10-1 Introduction to RS-232C Connections .....	392
10-2 Controlling Operation and Outputting Data with RS-232C No-protocol Communications .....	393

# 10-1 Introduction to RS-232C Connections

You can connect an RS-232C Interface Sensor Data Unit to the I/O cable connector on the FQ2. If you connect a Sensor Data Unit, you can use no-protocol communications to send and receive commands, inspection item parameters, and other data between the Sensor and the external control device that is connected with the RS-232C cable.

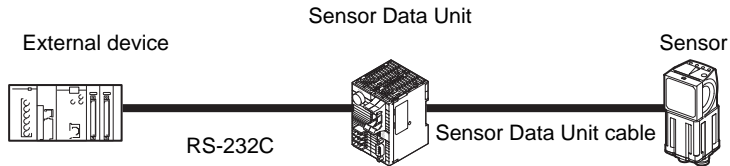

Refer to the following sections for the specifications and wiring methods of the RS-232C Interface Sensor Data Unit: (p. 32, p. 483) and *Wiring Sensor Data Units* (p. 44).

## Note

### Parallel Input Signals for an RS-232C Interface Sensor Data Unit

If you make a parallel connection through the parallel I/O connector on the Sensor Data Unit, the specifications of the parallel I/O signals will change as given below in respect to the standard parallel communications of the Sensor.

- Output Signals

You can use the ACK signal in the parallel outputs. Refer to the following section for the specifications of the ACK signal.

8-2 Controlling Operation and Outputting Data with a Parallel Interface Sensor Data Unit: p. 256

## 10-2 Controlling Operation and Outputting Data with RS-232C No-protocol Communications

If you connect an RS-232C Interface Sensor Data Unit to the Vision Sensor, you can use no-protocol communications between an external device (such as a PLC) and the Vision Sensor to perform control from the external device via command/response communications or to output data after measurements.

You can use these communications methods simultaneously.

### ● Command/Response Communications

With no-protocol communications, the external device sends a control command to the Vision Sensor and receives a response back from the Vision Sensor. This allows you to control the operation of the Vision Sensor (e.g., perform single measurements or change the scene).

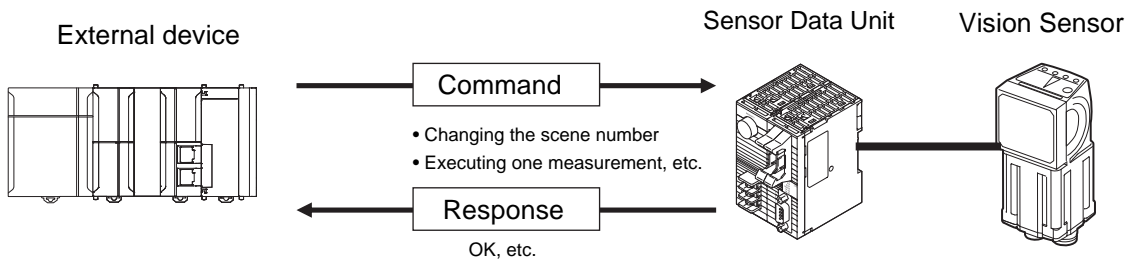

The external device sends a command as an ASCII string (e.g., "MEASURE" for a single measurement). The Vision Sensor then returns a response such as "OK", "NG", or some value.

### ● Data Output after Measurements

Immediately after a single or continuous measurement, the Vision Sensor will automatically output to an external device (e.g., a PLC) the data for measurements that are specified for output in advance. This enables you to easily transfer the measurement results data for inspection items to the external device.

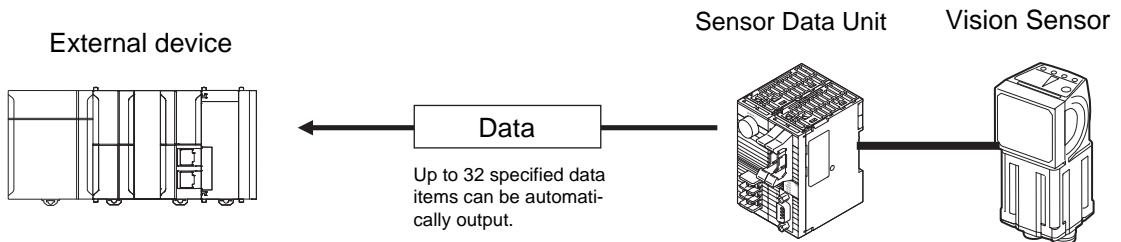

You must specify in advance the data to output (up to 32 items) after measurements. That data is sent to the external device in either ASCII or binary format through a continuous serial connection. There is no handshaking from the external device to confirm if it can receive the data.

## Setting Up No-protocol Communications

### Setting Network Settings in the Sensor

This section describes how to set the IP address and other network settings in the Vision Sensor. Refer to the following section for details.

 2-5 Setting Up Ethernet: p. 53

### Initial Settings for No-protocol Communications

To perform no-protocol communications with RS-232C, you must set the communications baud rate, data length, and other RS-232C communications parameters.

► **[Sensor settings] – [Data output] – [No-protocol data]**

- 1 Press **[Communication type] – [No protocol (RS-232C)]**.
- 2 Set the RS-232C communications parameters.

#### Note

If you connect to an OMRON PLC, set the PLC to Host Link communications.

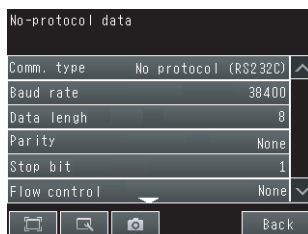

No-protocol data	
Comm. type	No protocol (RS232C) ^
Baud rate	38400
Data length	8
Parity	None
Stop bit	1
Flow control	None v

Item	Description	Parameter
Baud rate [bps]	Set the baud rate to use for RS-232C communications. Set the same baud rate as the external device that you will communicate with.	2400, 4800, 9600, 19200, 38400, 57600, or 115200 (default: 38400)
Data length [bits]	Set the same data length as the external device that you will communicate with.	7 bits or 8 bits (default: 8 bits)
Parity	Sets the parity. Set the same setting as the one in the PLC communications specifications.	None, Odd, or Even (default: none)
Stop bit	Set the number of stop bits. Set the same value as the one in the PLC communications specifications.	1 bit or 2 bits (default: 1 bit)
Flow control	Controls the flow of communications with the software.	None or Xon/Xoff (default: none)
Delimiter	Set the delimiter to add to the end of commands and responses. Set the same delimiter as the external device that you will communicate with.	CR, LF, or CR+LF (default: CR)
Interval timeout	Set the time in seconds to generate a timeout error.	1 to 120 s, 0: Not monitored. (default: 0 s)
Total timeout	Set the time in seconds to generate a timeout error.	1 to 120 s, 0: Not monitored. (default: 0 s)



## Setting the Data To Output Automatically after Measurements

You can set the data to output automatically after measurements. (You can set up to 32 data items.)

### Data That Can Be Output

You can output up to 32 data items (data 0 to data 31).

The measurement data from inspection items that can be output and the calculation results from the expression settings can be output. For data that can be output, refer to the *Measurement Data That Can Be Used for External Outputs and Calculations* for each inspection item.

The setting procedure is the same as for no-protocol communications for an Ethernet connection.

 Setting the Data To Output Automatically after Measurements: p. 352

### Important

Data Output Time and TRIG Signal Input Interval

Set the input interval for the TRIG signal so that it is equal to or greater than the data output time. If the input interval for the TRIG signal is shorter than the data output time, the output data buffer will eventually overflow and output data will be discarded.

### Setting the Output Format

Set the output format for the output data.

The setting procedure and the data output formats are the same as for no-protocol communications for an Ethernet connection.

 Setting the Output Format: p. 355

### Controlling the Sensor from an External Device (Procedure for No-protocol Command/Response Communications)

You can send commands from an external device to control the Sensor.

The commands and the command formats are the same as for no-protocol communications for an Ethernet connection.

 Controlling the Sensor from an External Device: p. 357



# Troubleshooting

---

11-1 Error Histories .....	398
11-2 Error Messages .....	400
11-3 Basic Troubleshooting .....	401

# 11-1 Error Histories

Error histories are stored with the PC Tool and in the Sensor and in the Touch Finder. Up to 100 errors will be stored in the error history in the Sensor or Touch Finder.





## Errors Stored in the Error History

Error in error history	Cause	Points to check	Measures to perform
TRIG Input Error  (Error code: 01040302)	A TRIG signal was input when the BUSY signal for Sensor measurement was ON.	<ul style="list-style-type: none"> <li>Check the program in the PLC or other host to see if an interlock or similar measure has been implemented.</li> <li>If a relay or other device with contacts is being used as the input device, see if chattering has occurred.</li> </ul>	<ul style="list-style-type: none"> <li>Program interlocks to control the TRIG so that they do not turn ON while the BUSY signal is ON.</li> <li>Switch from a device with contacts (e.g., relay) to a device without contacts (e.g., SSR or PLC transistor output).</li> </ul>
IN Input Error  (Error code: 11020900)	A no-protocol command or PLC link command was input when the BUSY signal was ON.	<ul style="list-style-type: none"> <li>Is an interlock or other counter-measure provided, e.g., in a ladder program in the PLC?</li> </ul>	<ul style="list-style-type: none"> <li>Program interlocks, such as in a ladder program, so that no-protocol commands and PLC link commands are not input while the BUSY signal is ON.</li> </ul>
Scene Data Error  (Error code: 01030800)	The scene data to switch to is corrupted.	---	The scene data to be switched to is corrupted. Reset the scene data from the beginning.
Model Error  (Error code: 01050405 or 01050500)	A model was re-registered with an image with low contrast.	Check the image to see if the contrast is too low to register the model.	Increase the image contrast and try again to register the model.
Logging Error (Error code: 02160702 or 02160703)	Some data was not saved when logging data to files on an SD card.	Check to see if the BUSY output parameter is set to <i>Measurement</i> .	Set a sufficiently long measurement interval or set the BUSY output condition to [Data logging] or [Image logging].
Communications error (Error code: 01010100)	Normal EtherNet/IP communications became impossible after they were established.	Check to see if communications were cut off with the data link partner device and to see if a cable is broken.	Check the cable connection to the data link partner device.
EtherNet/IP communications error (Error code: 01010101)	A timeout occurred in processing to output the measurement results via EtherNet/IP.	Make sure that handshake processing is being performed by the master. Also, make sure that the measurement interval is long enough.	Check the measurement interval and handshake processing. Change the timeout time so that it is suitable for the ladder program processing time.
Output buffer error (Error code: 01010701)	An output data buffer overflow occurred during output processing of measurement results for PLC Link or EtherNet/IP.	<ul style="list-style-type: none"> <li>Check the measurement interval to see if it is long enough.</li> <li>Make sure that handshake processing is being performed by the master.</li> </ul>	Check the measurement interval and handshake processing.
SD card output error (Error code: None)	A write to the SD card failed. An attempt was made to save more data than the available space on the SD card.	Check to see if the SD card is locked. Check to see if there is sufficient space available on the SD card.	Unlock the SD card. Delete unnecessary files from the SD card.

Note:  If an error that is indicated by this icon occurs, the ERROR operation indicator will light and the ERROR signal will turn ON.

## Note

You cannot check the error codes from the Touch Finder. Use the command to acquire the most recent error information for the connection method.

- EtherNet/IP  
 p. 313
- PLC Link  
 p. 346
- No-protocol Communications (TCP)  
 p. 374
- No-protocol Communications (FINS)  
 p. 389

## Checking the Error Histories

- **Checking the History of Errors That Have Occurred in the Sensor**

▶  (Setup Mode) – [Sensor settings] – [Error history] – [View history]

Errors will be displayed in order with the most recent ones on top.

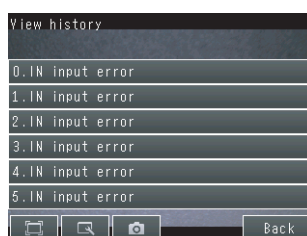

- **Checking the Log of Errors That Have Occurred in the Touch Finder**

▶  (Setup Mode or Run Mode) – [TF settings] – [Error history] – [View history]

## Clearing the Error Histories

- **Deleting the History of Errors That Were Detected in the Sensor**

▶  (Setup Mode) – [Sensor settings] – [Error history] – [Delete history]

- **Deleting the History of Errors That Were Detected in the Touch Finder**

▶  (Setup Mode or Run Mode) – [TF settings] – [Error history] – [Delete history]

## 11-2 Error Messages

If an error occurs while making settings on the PC Tool or the Touch Finder, an error message will appear on the display.

For these errors, the ERR indicator on the Sensor will not light, the ERROR signal will not be output, and the error will not be recorded in the error history.

Follow the instructions that are given in the error message.

If the following messages appear, the hardware may be faulty.

Contact your OMRON representative.

- System error.
- Application system error. Please reboot.
- Failed to startup.

# 11-3 Basic Troubleshooting

Problem	Measures to perform	Reference
The Sensor or Touch Finder will not start.	Check the power supply capacity to see if it is sufficient.	---
The Sensor cannot be detected.	Check the Ethernet cable to see if it is connected correctly.	---
	Check the Ethernet settings to see if they are correct between the devices.	p. 53
	Check if there are any Sensors that were not detected by the Sensor connection check.	p. 53
	Check the communications cable to see if it is disconnected.	---
	Check the switching hubs to see if any of them are faulty. (If switching hubs are used.)	---
	The PC Tool and Touch Finder cannot be connected at the same time. If the PC Tool or Touch Finder is already connected to the Sensor, disconnect it.	---
The results display is not updated.	Check to see if the TRIG signal is being correctly input to the Sensor.	p. 203
	Check to see if the most recent NG result is being displayed.	p. 201
Updating the results display is slow.	If other devices are connected to the same network as the Sensor, disconnect the other devices from the network and check the update speed. If the update speed returns to normal, check the specifications of the disconnected devices and take suitable measures.	---
	If there are power lines running in parallel with the Ethernet cable or if there are inverters or other sources of noise near the communications cable, separate the communications cable from them and check the update speed. Noise may be adversely affecting the communications response.	---
Data is not logged properly.	Check to see if the logging setting in the Sensor are correct.	p. 208
	If logging to an SD card is not possible, check the available space on the SD card and check to see if the SD card is write-protected.	p. 220
The ERROR indicator lights.	Check the error history to see what error has occurred and take suitable measures.	p. 398
The measurement trigger is not input.	Check to see if the measurement trigger is set correctly.	---
The image brightness does not stabilize. (FQ2-S1□□□□□□/ FQ2-S2□□□□□□ only)	Turn ON the brightness correction mode. When the Brightness Correction Mode is ON, the timing when images are taken changes. Check that the images of the measured objects taken when the Brightness Correction Mode is ON are appropriate.	p. 61

MEMO



# Appendices



---

<b>12-1 Menu Tables .....</b>	<b>404</b>
<b>12-2 External Reference Parameters.....</b>	<b>430</b>
<b>12-3 Specifications and Dimensions.....</b>	<b>472</b>
<b>12-4 Updating the Software.....</b>	<b>491</b>
<b>12-5 Connecting a Previous Touch Finder (FQ-D30/D31) to the FQ2-S Sensor .....</b>	<b>492</b>
<b>12-6 LED Safety .....</b>	<b>497</b>
<b>12-7 Requirements from Regulations and Standards .....</b>	<b>498</b>
<b>12-8 Detailed EtherNet/IP Communications Specifications.....</b>	<b>502</b>

# 12-1 Menu Tables

## Image Tab Page

Menu command		Description	Setting range	Data	Reference
Camera setup	Focus	The value shown here is used as a reference when adjusting the focus with the focus adjustment screw.	---	---	p. 60
	Image mode	Pixel sampling can be applied to the input image to reduce image input time.	Normal (default) or Fast	Scene	p. 174
	Shutter speed (Normal mode)	Sets the shutter speed for Normal Mode.	For FQ-S3 1/1 to 1/60,000 1/250 to 1/60,000 (for Sensors with Built-in Lighting) For FQ2-S1/FQ2-S2 1/1 to 1/50,000 1/250 to 1/50,000 (for Sensors with Built-in Lighting) Default: 1/250	Scene	p. 62
	Gain (Normal mode)	If the gain is high, the image will be bright. If the gain is low, the image will be dark.	For FQ-S3 Range: 0 to 10 (default: 0) For FQ2-S1/FQ2-S2 Range: 16 to 64 (default: 16)	Scene	p. 63
	Brightness (HDR mode)	Sets the brightness level of the image for HDR Mode.	1 to 100	Scene	p. 63
	HDR	Suppresses reflections and differences in brightness.	OFF(default), Level 1 to Level4	Scene	p. 64
	Brightness correction	Use to stabilize the brightness.	ON or OFF (default)	Scene	p. 65
	White balance	Corrects differences in coloring between the image and the actual object.	<ul style="list-style-type: none"> <li>• AUTO</li> <li>• R: 0.001 to 7.999</li> <li>• G: 0.001 to 7.999</li> <li>• B: 0.001 to 7.999</li> </ul>	Scene	p. 65
	Partial input	Used to make the image input range smaller.	FQ-S□□□□□□□□: 752×8 to 752×480 FQ-S□□□□□□□□-08□: 928×8 to 928×828 FQS3□□: 1280×8 to 1280×1024	Scene	p. 173
	Rotate 180	You can rotate the Camera image by 180°.	ON or OFF (default)	Scene	p. 230
	Calibration setting	Sets a registered calibration pattern.	Unregistered (default), New Calibration, or Calibration Data 0 to 31	Scene	p. 199
	Lightning control	Strobe output delay	Sets the delay time for the strobe output signal (STGOUT) in response to the trigger signal.	0 to 65,535 μs (default: 0 μs)	Scene
Strobe output time		Sets the output time of the strobe output signal (STGOUT).	0 to 65,535 μs (default: 1,000 μs)	Scene	p. 270
Trigger setup	Trigger delay	Adjusts the time until the Camera shutter opens after the trigger signal is received.	0 to 163 ms (default: 0)	System	p. 66

Menu command		Description	Setting range	Data	Reference		
Image adjustment	Add filter	These commands are used to add, modify, delete, copy, or change the name of filter items and position compensation items.	Color Gray Filter, Weak Smoothing, Strong Smoothing, Dilate, Erosion, Median, Extract Edges, Extract Horiz. Edges, Extract vertical edges, Enhance edges, Background Suppression	Scene	p. 70		
	Add pos. comp.		Model	Shape Sear. pos. comp., Search position comp.	Scene	p. 74	
			Edge	Edge position comp., 2Edge position comp. 2ed. midp. comp.Edge rot. pos. Comp.	Scene	p. 74	
	Modify		---	---	---	p. 70	
	Delete		---	---	---	p. 70	
	Copy		---	---	---	p. 70	
	Rename		15 alphanumeric characters	---	---	p. 70	
Image adjustment (filter)	 (Color Gray Filter)	Filter type	You can specify the ranges of colors to which the Color Gray Filter item is applied.	RGB (default), HSV	Scene	p. 71	
		Filter settings	Select the type of color filter to use.	Custom filter, HSV	Scene	p. 71	
		Source image	You must set the image to which the filter is to be applied.	Camera, Prev. (default)	Scene	p. 70	
		 (Items other than Color Gray Filter)	Filter region	You can specify the region to which to apply the filter.	---	Scene	p. 71
			Source image	You must set the image to which the filter is to be applied.	Camera, Prev. (default)	Scene	p. 70
			Suppression level (for Background Suppression Item Only)	The range in which to enhance the contrast and the brightness range to extract are set for the Background Suppression item.	---	Scene	p. 72

Menu command		Description	Setting range	Data	Reference	
Image adjustment (Position compensation items)	Basic	Teach for Search Position Compensation and Shape Search Position Compensation for Edge Position Compensation	Model region Used to specify the region of the image to register as the model with a combination of figures.	---	Scene	---
				Add	Rectangle, Ellipse, Wide circle, or Polygon	Scene
	Delete			---	Scene	---
	Copy			---	Scene	---
	Con-sole			---	Scene	---
	OR/NOT			OR (default) or NOT	Scene	---
	One/All			One or All	Scene	---
	Insp. region		Adjusts the size and position of the measurement region.	---	Scene	---
	Detection point		You can specify which part of the model to detect as coordinates during inspections	---	Scene	---
	Insp. region		Adjusts the size and position of the measurement region, changes the measurement direction, etc.	---	Scene	---
	Color ON/OFF		Sets whether to specify an edge color.	ON or OFF (default)	Scene	---
	Set color.		Specifies the color of the image for edge detection (i.e., the border between the measurement object and background).	R: 0 to 255 B: 0 to 255 G: 0 to 255	Scene	---
	Color palette		Displays a palette for color specification.			

Menu command		Description	Setting range	Data	Reference	
Image adjustment	Basic Teach	Edge 0 region Edge 1 region	Adjusts the size and position of the measurement region, changes the measurement direction, etc.	---	Scene	---
		Edge 0 clr ON/OFF Edge 1 clr ON/OFF	Sets whether to specify an edge color.	ON or OFF (default)	Scene	---
		Set color.	Specifies the color of the image for edge detection (i.e., the border between the measurement object and background).	R: 0 to 255 B: 0 to 255 G: 0 to 255	Scene	---
		Edit Ref. angle (Edge Rotation Position Compensation only)	Set the reference angle.	0 to 180° (default:0)	Scene	---
	Judgement	<ul style="list-style-type: none"> <li>Shape Search II Position Compensation Item and Search Position Compensation Item Almost the same as for the Search inspection item.</li> <li>Edge Position Compensation, Two-edge Position Compensation, Two-edge Midpoint Compensation, and Edge Rotation Position Compensation Almost the same as for the Edge Position inspection item.</li> </ul>	Scene	---		
	Details	Meas. Parameter	<ul style="list-style-type: none"> <li>Shape Search II Position Compensation Item and Search Position Compensation Item Almost the same settings as for the Search inspection item. However, the [Sub-pixel] and [Multi-point output] settings of the Search inspection item do not exist.</li> <li>Edge Position Compensation, Two-edge Position Compensation, Two-edge Midpoint Compensation, and Edge Rotation Position Compensation The settings for the Edge Position Compensation item are almost the same as those for the Edge Position inspection item.</li> </ul>	Scene	---	
		Output parameter		Scene	---	
		Scroll parameter	Source image	You can select the image to which to apply the results of position compensation processing.	Camera, Prev. (default)	Scene
	Interpolation		You can select the precision of position compensation.	Bilinear, None (default)	Scene	p. 77

## Inspect Tab Page

Menu command		Description	Setting range	Data	Reference
Inspection	Item selected	Used to add, modify, delete, copy, or change the name of an inspection item.	Search, Shape Search II, Sensitive Search, Edge Position, Edge Width, Edge Pitch, Area, Color Data, Labeling	---	p. 93
			---	---	p. 94
			---	---	p. 94
			---	---	
			15 alphanumeric characters	---	

Menu command		Description	Setting range	Data	Reference			
Inspection	Settings	Teach	for Search, Shape Search II, Sensitive Search	Model region	Used to specify the region of the image to register as the model with a combination of figures.	---	Scene	p. 100, p. 110, p. 117
				Add		Rectangle, Ellipse, Wide circle, or Polygon	Scene	p. 100
				Delete		---	Scene	
				Copy		---	Scene	---
				Console		---	Scene	p. 101
				OR/NOT		OR (default) or NOT	Scene	p. 101
				One/All		One or All	Scene	---
			Insp. region	Adjusts the size and position of the measurement region.	---	Scene	p. 102	
			Detection point	You can specify which part of the model to detect as coordinates during inspections.	---	Scene	p. 102	
		for Edge Position, Edge Width, and Edge Pitch	Insp. region	Adjusts the size and position of the measurement region, changes the measurement direction, etc.	---	Scene	p. 125, p. 129, p. 133	
			Color ON/OFF (for Edge width and Edge position Only)	Sets whether to specify an edge color.	ON or OFF (default)	Scene	p. 124	
			Set color.	Specifies the color of the image for edge detection (i.e., the border between the measurement object and background).	R: 0 to 255 B: 0 to 255 G: 0 to 255	Scene		
			Color palette	Displays a palette for color specification.				
		for Area, Labeling	Insp. region	Adjusts the size and position of the measurement region.	---	Scene	p. 144, p. 152	
			Set color	The color for which to find the area is specified.	---	Scene	p. 142, p. 148	
			Color palette	Displays a palette for color specification.	Hue: 0 to 359, Saturation: 0 to 255 Brightness: 0 to 255 Exclusion: ON or OFF Color inv.: Yes or No (default)	Scene		
			Display Setting	Specifies the type of image to display on the color specification display to check on the image the color that was set for the reference color.	Measurement Image, All Color Image (default), Selected Color Image, or Binary Image	Scene		
			Background color	Specifies the background color of the extracted image.	Black (default), white, red, green, or blue	Scene		
		for Color Data	Insp. region	Moves the measurement region or adjusts the size of the measurement region.	---	Scene	p. 139	

Menu command		Description	Setting range	Data	Reference		
Inspection	Settings	Judgement		Scene	---		
		(Sensitive search)	Detection No.	If you enabled the output of multiple results, you can specify the results to display.	---	Scene	p. 96, p. 106, p. 114
			Correlation	Sets the correlation OK range.	0 to 100 (Defaults: Lower limit: 0, Upper limit: 100)	Scene	
			Position X	Sets the position OK range.	(Defaults: Lower limit: -99,999.9999, Upper limit: 99,999.9999)	Scene	
			Position Y		(Defaults: Lower limit: -99,999.9999, Upper limit: 99,999.9999)	Scene	
			Angle	Sets the angle OK range.	-180 to 180 (Defaults: Lower limit: -180, Upper limit: 180)	Scene	
			Count	Sets the count OK range.	0 to 32 (default: 0)	Scene	
		(Edge position)	Position X	Sets the position OK range.	-99,999.9999 to 99,999.9999 (Defaults: Lower limit: -99,999.9999, Upper limit: 99,999.9999)	Scene	p. 121
			Position Y		-99,999.9999 to 99,999.9999 (Defaults: Lower limit: -99,999.9999, Upper limit: 99,999.9999)	Scene	
		(Edge width)	Edge width	Sets the Edge width OK range.	<ul style="list-style-type: none"> <li>When the result type is set to relative values: Range: -99,999.9999 or 99,999.999 Default: Upper limit: 99,999.9999, Lower limit: -99,999.9999</li> <li>When the result type is set to ratios: Range: 0.000 to 999.9999(%) Default: Upper limit: 999.9999, Lower limit: 0.000</li> </ul>	Scene	p. 128
		(Edge pitch)	Edge pitch	Sets the Edge pitch OK range.	Range: 0 to 1000 Defaults: Lower limit: 0, Upper limit: 1000	Scene	p. 132
			Average pitch		Range: 0.0000 to 99,999.9999 Defaults: Lower limit: 0.0000, Upper limit: 99,999.9999	Scene	
			Max. pitch (maximum pitch)		Scene		
			Min. pitch (minimum pitch)		Scene		
			Average width		Scene		
			Max. width (maximum pitch)		Scene		
			Min. width (minimum pitch)		Scene		

Menu command		Description	Setting range	Data	Reference		
Inspection	Settings	Judgement (Color Data)	Color difference	Sets the upper and lower limits of the difference between the average color and reference color that is to be judged as OK.	0.0000 to 442.0000	Scene	p. 137
			Color deviation	Set the upper and lower limits of the range of the deviation in the region that is to be judged as OK.	0.0000 to 221.0000	Scene	
			R average	Set the difference in the average value of the R (red) component that is to be judged as OK.	0.0000 to 255.0000	Scene	
			G average	Set the difference in the average value of the G (green) component that is to be judged as OK.	0.0000 to 255.0000	Scene	
			B average	Set the difference in the average value of the B (blue) component that is to be judged as OK.	0.0000 to 255.0000	Scene	
	(Area)	Area	Set the upper and lower limits for an OK judgement.	Range: 0.00000 to 999,999,999.9999 Default: Upper limit: 999,999,999.9999, Lower limit: 0.0000	Scene	p. 142	
		Gravity X	Set the upper and lower limits of the range of gravity X that is to be judged as OK.	Range: -999,999,999.9999 to 999,999,999.9999 Default: Upper limit: 999,999,999.9999, Lower limit: -999,999,999.9999	Scene		
		Gravity Y	Set the upper and lower limits of the range of the gravity Y that is to be judged as OK.	Range: -999,999,999.9999 to 999,999,999.9999 Default: Upper limit: 999,999,999.9999, Lower limit: -999,999,999.9999	Scene		
	(Labelling)	Number of labels	Set the upper and lower limits of the number of labels for an OK judgement.	0 to 100 (defaults: upper limit: 100, lower limit: 0)	Scene	p. 147	
		Total label area	Set the upper and lower limits of the total label area for an OK judgement.	0 to 999,999,999.9999 (defaults: upper limit: 999,999,999.999, lower limit: 0)	Scene		
		Area	Sets the upper and lower limits of the area for an OK judgement.	0 to 999,999,999.9999 (defaults: upper limit: 999,999,999.999, lower limit: 0)	Scene		
		Gravity X	Set the upper and lower limits of the gravity X for an OK judgement.	-99,999.9999 to 99,999.9999 (defaults: upper limit: 99,999.9999, lower limit: -99,999.9999)	Scene		
		Gravity Y	Set the upper and lower limits of the gravity Y for an OK judgement.	-99,999.9999 to 99,999.9999 (defaults: upper limit: 99,999.9999, lower limit: -99,999.9999)	Scene		
		Master angle	Sets the upper and lower limits of the master angle for an OK judgement.	-180 to 180 (defaults: upper limit: 180, lower limit: -180)	Scene		
	◀	Result type (Except for Edge Position, Edge Pitch, and Labeling)	You can change the output form of the measurement values.	Absolute value (default), Relative value, or Ratio (Edge Position or Area only)	Scene	p. 97, p. 107, p. 115, p. 122, p. 129, p. 133	
		Display setting	You can change the parameters of the judgement conditions.	The names of the judgement conditions are displayed.	Scene	p. 96, p. 106, p. 114, p. 121, p. 128, p. 132, p. 137 p. 141	
		Auto adjustment (Except for Labeling and Edge Pitch)	Automatically adjusts the judgement parameters by using actual workpieces which are considered as good or faulty products.	OK Teach or NG Teach	Scene	p. 175	



Menu command		Description	Setting range	Data	Reference		
Inspection	Details (Search)	Model parameter	Rotation	Sets the angle range for the registered model.	No (default), Yes	Scene	p. 99
		Model parameter	Angle range		-180 to 180	Scene	p. 99
	Meas. Parameter	Meas. Parameter	Sub-pixel	You can increase the accuracy of measurement positioning.	No (default), Yes	Scene	p. 97
		Meas. Parameter	Extraction condition			Scene	
			Candidate level	Sets the detection target to only objects with a correlation above the specified candidate level.	0 to 100 (default: 60)	Scene	p. 98
			Extraction X	Results are output only for objects with a measured X coordinate that is within this range.	-999,999,999.9999 to 999,999,999.9999	Scene	
			Extraction Y	Results are output only for objects with a measured Y coordinate that is within this range.	-999,999,999.9999 to 999,999,999.9999	Scene	
			Detection count	Sets the maximum number of detection results to output.	1 to 32	Scene	
			Multi-point output	Sets whether to output only the result with the highest correlation, or to output all results that meet the specified extraction conditions.	OFF (default) or ON	Scene	p. 98
		Sorting method	Sets the sort condition to use when multiple measurement results meet the extraction conditions.	Corr. ascending order, Corr. descending order (default), Pos.X ascending order, Pos.X descending order, Pos.Y ascending order, Pos.Y descending order	Scene	p. 97	
	Output parameter	Reflect	You can specify whether to reflect the measurement results of an inspection item in the overall judgement.	None, Yes (default)	Scene	p. 98	

Menu command		Description	Setting range	Data	Reference				
Inspection	Details	(Shape search II)	Model parameter	Rotation	Sets the angle range for the registered model.	No (default), Yes	Scene	p. 109	
			Angle range			-180 to 180	Scene	p. 109	
	Meas. Parameter	Model parameter	Model mode	You can change to a mode that makes it easier to search for images similar to a model.		Fast (default), Stable	Scene	p. 109	
			Extraction condition					Scene	p. 108
				Candidate level	Sets the detection target to only objects with a correlation above the specified candidate level.	0 to 100 (default: 60)	Scene		
			Extraction X	Results are output only for objects with a measured X coordinate that is within this range.		-999,999,999.9999 to 999,999,999.9999	Scene		
			Extraction Y	Results are output only for objects with a measured Y coordinate that is within this range.		-999,999,999.9999 to 999,999,999.9999	Scene		
			Detection count	Sets the maximum number of detection results to output.		1 to 32	Scene		
			Sorting method	Sets the sort condition to use when multiple measurement results meet the extraction conditions..		Corr. ascending order, Corr. descending order (default), Pos.X ascending order, Pos.X descending order, Pos.Y ascending order, Pos.Y descending order	Scene	p. 107	
			Output parameter	Reflect	You can specify whether to reflect the judgement results of an inspection item in the overall judgement.		No, Yes (default)	Scene	p. 108
				Model parameter	Rotation	Sets the angle range for the registered model.		No (default), Yes	Scene
			Angle range					-180 to 180	Scene
	Meas. Parameter	Model parameter	Sub-model number	You can change the number of divisions of the registered model.		3 × 3, 5 × 5 (default), or 9 × 9	Scene	p. 110	
			Plain inspection	Enables or disables inspecting plain sections.		Yes or No (default)	Scene	p. 110	
			Sub-pixel	You can increase the accuracy of measurement positioning.		No (default), Yes	Scene	p. 115	
	Output parameter	Meas. Parameter	Candidate level	Sets the detection target to only objects with a correlation above the specified candidate level.		0 to 100 (default: 60)	Scene	p. 115	
			Reflect	You can specify whether to reflect the judgement results of an inspection item in the overall judgement.		No, Yes (default),	Scene	p. 115	
	Output parameter	Meas. Parameter	Edge position	Edge level	Sets the color density level of the edge.		0 to 100 (default: 50)	Scene	p. 122, p. 133, p. 129
				Noise level	Sets the color density level to treat as noise.		0 to 442 (default: 5)	Scene	p. 123, p. 133, p. 129
			Reflect	You can specify whether to reflect the judgement results of an inspection item in the overall judgement.		No, Yes (default),	Scene	p. 122, p. 133, p. 129	

Menu command		Description	Setting range	Data	Reference			
Inspection	Details (Color/ Data)	Output parameter	Reflect	You can specify whether to reflect the judgement results of an inspection item in the overall judgement.	No, Yes (default),	Scene	p. 138	
		(Area)	Meas. Parameter	Fill profile	You can set how to process holes for an Area inspection item.	None (default), Filling up holes, Fill Outline	Scene	p. 144
		Output parameter	Reflect	You can specify whether to reflect the judgement results of an inspection item in the overall judgement.	No, Yes (default),	Scene	p. 142	
	Labeling	Meas. Parameter	Filling up holes	Sets how to process areas surrounded by the specified color.	Yes, No (default)	Scene	p. 150	
			Extract image	Select this option if there are areas of the specified color inside the measurement region that you do not want to measure.	Yes, No (default)	Scene	p. 150	
			Extraction condition			Scene	p. 151	
			Number of labels	Set the maximum number of labels to detect.	Range: 1 to 100 Default: 100	Scene		
			Area	Specify the area range to judge as a label.	Range: 0 to 999,999,999.9999 Defaults: Upper limit: 999,999,999.9999, Lower limit: 0	Scene		
			Gravity X	Specify the gravity X position to judge as a label.	Range: -99,999,999.9999 to 999,999,999.999 Defaults: Upper limit: 999,999,999.999, Lower limit: ?999,999,999.9999	Scene		
			Gravity Y	Specify the gravity Y position to judge as a label.	Range: -999,999,999.9999 to 999,999,999.999 Defaults: Upper limit: 999,999,999.999, Lower limit: -999,999,999.9999	Scene		
		Sorting method	Set the condition to use for label number reassignment.	Area ascending order, Area descending order (default), Pos. X ascending order, Pos. X descending order, Pos. Y ascending order, Pos. Y descending order	Scene	p. 151		
	Output parameter	Reflect	You can specify whether to reflect the judgement results of an inspection item in the overall judgement.	No, Yes (default),	Scene	p. 152		

Menu command		Description	Setting range	Data	Reference		
Calculation	Settings	Expression [MENU]	Expression 0 to expression 31	Sets the number of the expression for which to set a calculation.	---	Scene	p. 157
			Expression settings	Sets the expressions.	---		
			Data	Uses the measurement result of other items.	Inspection item, calculation symbols ( ) / * . , + TJG)	Scene	p. 162
			Const.	Inputs constants or mathematical operators.	0 to 9, ., calculation symbol ( ) / * ? , + TJG)	Scene	p. 157
			Math.	Uses functions in expressions.	SIN, COS, ATAN, AND, OR, NOT, ABS, MAX, MIN, MOD, SQRT, ANGL (angle of straight line joining two points (center of gravity and model center)), DIST (distance between two points), calculation symbols ( ) / * . , + TJG)	Scene	p. 159
			Rename	Deletes/copies the expression or changes the expression name.	---	Scene	p. 157
			Copy		---	Scene	
			Delete		---	Scene	
			Judgement	Specifies the parameters for judgement of results.		Scene	p. 161
			Details	Output parameter	Reflect	You can specify whether to reflect the judgement results of a calculation in the overall judgement.	No, Yes (default),

## In/Out Tab Page

Menu command		Description	Setting range	Data	Reference	
Log setting	Statistical data		Sets whether to record the number of measurements and the number of NG overall judgements.	ON (default) or OFF	System	p. 214
	Image logging		Sets the parameter to log measurement image data.	All, Only NG, or None (default)	System	p. 209, p. 214
	Data logging	Condition	Sets the parameter to log measurement data from inspection items.	All, Only NG, or None (default)	System	p. 209
		Select data	You can select the parameters to log from the parameters in the filter items, position compensation items, inspection items and expression that are set.	Parameter names for the filter items, position compensation items, inspection items and expression that are set	System	p. 209
Delete Log		Resets the log data without turning OFF the power supply.	---	System	p. 216	

Menu command		Description	Setting range	Data	Reference		
I/O setting	I/O setting	Output	OUT0	Used to assign output signals to OUT0, OUT1, and OUT2.	OR (total judgement) (default), READY, RUN, STG (strobe trigger), OR0 (item 0 judgement) to OR31 (item 31 judgement) and expression 0 judgement to expression 31 judgement	System	p. 242
			OUT1		BUSY (default), READY, RUN, STG (strobe trigger), OR0 (item 0 judgement) to OR31 (item 31 judgement) and expression 0 judgement to expression 31 judgement	System	
			OUT2		ERROR (default), READY, RUN, STG (strobe trigger), OR0 (item 0 judgement) to OR31 (item 31 judgement) and expression 0 judgement to expression 31 judgement	System	
		OR output	You can set the output conditions for the OR signal and for output signals to which judgements are assigned.	OK: ON or NG: ON (default)	System	p. 244	
		Output mode	You can set the output mode for the OR signal and for output signals to which judgements are assigned.	One-shot output, Level output (default)	System	p. 242	
		Output delay	When one-shot output mode is selected, this parameter sets the delay from when measurement processing is completed until when the OR signal turns ON.	0 to 1,000 ms (default: 0 ms)	System		
		Output time	When one-shot output mode is selected, this parameter sets the time that the OR signal is ON.	1 to 1,000 ms (default: 5 ms)	System		
		BUSY output	Specifies when to turn OFF the BUSY signal after starting measurement processing.	Measurement (default), Data logging, Image logging, or Result display	System	p. 245	
		OUT0 Polarity	You can change the polarity of the output signals that are assigned to OUT0 to OUT2 (regardless of what signal is assigned to the output).	Positive (default), Negative	System	p. 245	
		OUT1 Polarity		Positive (default), Negative	System		
		OUT2 Polarity		Positive (default), Negative	System		
		BUSY LED	You can change the BUSY indicator to a RUN indicator.	BUSY (default), RUN	System	p. 231	
		Output control	You can select the data output method. (Only when the FQ-SDU1□ is connected.)	None (default), Handshaking, or Sync. Output	System	p. 263	

Menu command		Description	Setting range	Data	Reference	
I/O setting	I/O setting Output	Output period	Sets the period for outputting measurement results. (Only when the FQ-SDU1□ is connected.)	2.0 to 5,000.0 ms 10.0 ms (default)	System	p. 263
		GATE ON delay	Sets the time from when the result is output to the parallel interface until the GATE signal turns ON. (Only when the FQ-SDU1□ is connected.)	1.0 to 1,000.0 ms 1.0 ms (default)	System	p. 263
		Output time	Sets the time to turn ON the GATE signal. (Only when the FQ-SDU1□ is connected.)	1.0 to 1,000.0 ms 5.0 ms (default)	System	p. 263
		Timeout	Sets the timeout time for output control. (Only when the FQ-SDU1□ is connected.)	0.5 to 120.0 s 10.0 s (default)	System	p. 263
		Number of delay	Set the number of times to ignore the TRIG signal turning ON between when the TRIG signal turns ON and the measurement results are output. (Only when the FQ-SDU1□ is connected.)	1 to 15 (default)	System	p. 263
		ACK signal ON period	Sets the output time of the normal execution completion signal for parallel commands. (Only when the FQ-SDU is connected.)	1.0 to 1,000.0 ms 5.0 ms (default)	System	p. 270
		Output polarity	Sets the ON/OFF polarity for all of the output signals (Only when the FQ-SDU is connected.)	Positive(default), Negative	System	p. 270
	Input	Input mode	Specifies whether to use functions other than scene switching for external parallel commands.	Standard mode (default) or Expanded mode	System	p. 247

Menu command		Description	Setting range	Data	Reference		
I/O setting	Output data setting	Noprotocol data output [MENU]	Output data set	---	Data 0 to data 31	p. 352, p. 353, p. 355	
			Data settings	Sets data to output to selected data number.	Text strings for the filter items, position compensation items, inspection items and expression that are set		---
			Multi-data setting				---
			Rename	Changes the name of the selected data number.	The name can be changed to a name with up to 15 alphanumeric characters.		---
			Copy	Copies the contents registered in the selected data number to another data number.			---
			Delete	Clears the content of the selected data number.			---
	Output form		---	---	---	p. 333	
	Output form		Selects the format of the data to be output.	ASCII (default) or Binary	Scene	p. 355	
	When output format is ASCII	Digits of integer	Sets the digits of the integer part, including the sign. However, + is not output for positive numbers. Example: Setting 4-digit data: -5963 is output as -999.	1 to 10 (Default: 6)	Scene		
		Digits of decimal	Sets the output digits for the decimal part. If it is set to 0, the decimal part is rounded off before the data is output.	0 to 4 (default: 4)	Scene		
		Negative	Selects what to display as the sign when the number is negative.	- (Default) or 8	Scene		
		0 suppress	Selects the method to adjust unused digits on the left in output data. ON: Zeros are inserted for unused digits. OFF: Spaces are inserted for unused digits. Example: The following examples are for when five integer digits and three decimal digits are set and the data is 100.000. ON: 00100.000 OFF: _100.000 (The underscore indicates a space.)	ON or OFF (default)	Scene		

Menu command		Description	Setting range	Data	Reference				
I/O setting	Output data setting	Noprotocol data output	Output form	When Output Format is ASCII	Field separator	Selects the separator to use between output data.	None (default), comma, tab, space, CR, LF, or CR+LF	Scene	p. 355
				When Output Format is ASCII	Record separator	Selects the separator to use between sets of output data.	None (default), comma, tab, space, CR, LF, or CR+LF	Scene	
				When output format is Binary	Decimal output form	Selects the numerical expression for binary output. Fixed-decimal-point data is multiplied by 1,000 and the result is output.	Floating-point decimal or fixed decimal (default)	Scene	
	Link data output	Output data set		The same as for no-protocol data output, above.	Scene	p. 300, p. 333			
		Output format			Scene				
Par. Jdg Output(Only when the FQ-SDU1□□ is connected.)	Basic	Settings		---	Data0 to Data15	Scene			
		 Settings	Sets the data from the inspection item to judge.	Inspection item text strings	Scene	p. 258			
		Rename	Changes, copies, or clears the data.	---	Scene				
		Copy			Scene				
		Delete			Scene				
	Judgement condition	Data 0 to Data 15	Sets the range of the output data to judge OK.	Range: -999,999,999.9999 to 999,999,999.999 Defaults: Upper limit: 999,999,999.999, Lower limit: -999,999,999.9999	Scene				
	Details	Output parameter	Reflect	You can specify whether to reflect the judgement results of an inspection item in the overall judgement.	No, Yes (default)	Scene	p. 259		
Data output		Sets whether to output the judgement results.	No, Yes (default)	Scene	p. 259				



Menu command		Description	Setting range	Data	Reference	
I/O setting Par. Data Output (Only when the FQ-SDU1□ is connected.)	Basic	Data settings	---	Data0 to Data31	Scene	
		Data settings	Sets the output data.	Inspection item text strings	Scene	p. 259
	Rename	Changes, copies, or clears the data.	---	Scene		
	Copy			Scene		
	Delete			Scene		
	Output format	Output format	Sets the output form.	Binary(default) or BCD	Scene	p. 260
	Output parameter	Data output	Output form	Sets whether to output the data.	No, Yes (default)	Scene
I/O monitor	I/O monitor	Used to check I/O connections.	---	---	p. 203	

## Test Tab Page

Menu command		Description	Setting range	Data	Reference
Continuous test		Used to check the individual judgement results for the inspection items and to adjust the judgement parameters.	---	---	p. 170
	Graphic	Displays the input image.			
	Graphics + Details	Displays the inspection item individual judgement results and measurement values.			p. 177
	All results/Region	Displays the inspection item individual judgement results for all inspection items.			
	Trend Monitor	Displays the individual judgement results saved in the Sensor in a trend monitor.			p. 170
	Histogram	Displays the individual judgement results saved in the Sensor in a histogram.			

Menu command		Description	Setting range	Data	Reference	
Continuous test	Model region	Same as for the Search item settings.		Scene		
	Insp. region			Scene		
	Adjust judgement	Adjusts judgement parameters without stopping measurements.	---	Scene	p. 175	
	Auto adjustment	Automatically adjusts the judgement parameters by using actual workpieces which are considered as good or faulty products.	OK Teach, NG Teach			
	Method	Selects the expression to use to automatically adjust the judgement parameters.	Threshold (minimum), Threshold (average) (default), or Threshold (maximum)			
	Auto display (trend monitor and histogram only)	Same as the trend monitor and histogram for [Run] Mode.		---	p. 184, p. 185	
	Display range (trend monitor and histogram only)					
	Number of data (trend monitor only)					p. 184
	Number of data (histogram only)					p. 185
Erase display						
Save data	Saves scene data, Calibration data, and system data.	---	---	p. 178		

## Run Tab Page (from Setup Display)

Menu command	Description	Setting range	Data	Reference
Switch to Run mode	Switches to Run Mode.	---	---	p. 180

## Tool

### Setup Mode

Menu command	Description	Setting range	Data	Reference
Select scene		---	---	p. 190
Select	Switches to a registered scene.	---		
Rename	Used to delete, copy, or change the name of a scene.	15 alphanumeric characters		
Copy		---		
Clear				

Menu command		Description	Setting range	Data	Reference		
Calibration	Select	Sets a registered calibration pattern.	Calibration data 0 to 31	Scene	---		
	Modify	Used to edit calibration data.	Calibration data 0 to 31	Scene	---		
	Specify point	Sets the type of calibration data to set.	---	---	p. 194		
	Reference		---	---	p. 196		
	Parameter		---	---	p. 198		
	Modify	Sets the parameters for the calibration data.	---	---	---		
	(Specify point)	Specify point coord.	Sets the Camera coordinates.	---	Calibration data	p. 194	
			Actual coord.	Sets the Camera coordinates and the actual coordinates.	Point coordinate: 0 to 9999 Actual coordinate: 0 to 99999.9999		Calibration data
			Model region	Used to edit the model regions. The procedure is the same as for setting the model region for a Search inspection item.	---		Calibration data
	(Reference sampling)	Insp. region	Changes the size and position of the measurement region.	---	Calibration data		
		Actual coord.	Sets the Camera coordinates and the actual coordinates.	Point coordinate: 0 to 9999 Actual coordinate: 0 to 99999.9999	Calibration data		
		Coordinate	Sets the positive direction when specifying coordinates.	Righthand, Lefthand (default)	Calibration data	p. 198	
	Origin	Select the location of the origin of the coordinate system.	Lowerleft, Upperleft (default), or Center	Calibration data			
	Magnification	Set the actual dimension that corresponds to one pixel.	0.0001 to 9.9999 (default:1.0000)	Calibration data			
	Clear	Clears the parameter settings for the calibration data.	---	---	---		
	Copy	Copies the calibration data.	---	---	---		
	Rename	Changes the name of the calibration data.	15 alphanumeric characters max.	---	---		

Menu command		Description	Setting range	Data	Reference	
Save to file	Setting	Scene data	Saves scene data with an SCN file name extension.	---	---	p. 218
		Scene group data	Saves all scene data with an SGP file name extension.			
		Calibration data	Saves calibration data with an CLB file name extension.			
		Calibration group data	Saves calibration group data with an CGP file name extension.			
		Sensor system data	Saves system data with an SYD file name extension.			
		All Sensor data	Saves all Sensor data with a BKD file name extension.			
		Touch Finder data	Saves Touch Finder data with an MSD file name extension.			
Logging	Statistical data	Saves statistical data with a CSV file name extension.	---	---	p. 209, p. 210	
	Logging image	Saves image data with an IFZ file name extension.				
	Logging data	Saves measurement data with a CSV file name extension.				
Load from file	Scene data	Loads scene data.	---	---	p. 219	
	Scene group data	Loads scene group data.				
	Calibration data	Loads calibration data.				
	Calibration group data	Loads calibration group data.				
	Sensor system data	Loads system data.				
	All Sensor data	Loads all Sensor data.				
	Touch Finder data	Loads Touch Finder data.				
Sensor settings	Information		Used to check the Sensor information.	---	System	p. 230
	Model	Used to check the model and software version of the connected Sensor.				
	Version					
	Name	Displays the name of the connected Sensor.				
	MAC address		Used to check the MAC address of the connected Sensor.	---	---	
		Rename	Used to change the name of a connected Sensor.	15 alphanumeric characters max.	---	p. 230
		Memory state	Used to check the status of Sensor memory.	---	---	p. 230
	Error history	View history	Displays a history of errors that have occurred in the Sensor.	---	System	p. 398
Delete history		Deletes the error history.	---		---	p. 399

Menu command		Description	Setting range	Data	Reference		
Sensor settings	Startup settings	Startup mode	Sets whether the startup scene number is set manually.	ON or OFF (Scene number when settings were saved is startup scene number.)	System	p. 192	
		Startup scene	Set the scene number to use at startup.	Standard models: 0 to 31, Single-function models: 0 to 7, Default: 0			
	Password settings	Password ON/OFF	Enables (ON) or disables (OFF) the password.	OFF (default) or ON	System	p. 223	
		Enter password	Sets a password.	15 characters max.			
Adjustment mode in Run		Sets whether to adjust measurement contents in Run Mode.	OFF (default) or ON	---	p. 187		
Network settings	Ethernet					p. 53	
	IP address setting	Sets the method to use to set IP addresses.	Auto (default), Fixed, DHCP	System			
	IP address	Enter the IP address of the Sensor. (Valid only when the [IP address setting] is set to [Fixed].)	a.b.c.d a: 1 to 223 b: 0 to 255 c: 0 to 255 d: 2 to 254 (Default: 10.5.5.100)	System		p. 53	
	Subnet mask	Inputs the subnet mask. (Valid only when the [IP address setting] is set to [Fixed].)	0.0.0.0 to 255.255.255.255 (Default: 255.255.255.0)	System		p. 53	
	Gateway	Sets the default gateway address. (When the [IP address setting] is set to [Fixed].)	1.0.0.1 to 223.255.255.254 (Default: 10.5.5.7)	System			
Data output	No-protocol data	Communication type	Sets the communications type to use to output no-protocol data.	Invalid (default), No protocol (TCP), No protocol (FINS), No protocol (RS-232C)	System	p. 351, p. 394	
		When the communications type is TCP no-protocol or FINS/TCP no-protocol					
		Connection mode	Sets whether to communicate with the communications devices as a server device or a client device.	TCP server (default), TCP client	System		p. 351
		IP address	Sets the IP address to which to output no-protocol data. * Setting is not possible if the connection mode is set to a TCP server.	a.b.c.d a: 1 to 223 b: 0 to 255 c: 0 to 255 d: 1 to 254 (Default:10.5.5.111)	System		p. 351
		Port No.	Sets the output port number. * Setting is not possible if the connection mode is set to a TCP server.	0 to 65535 (Default: 9600)	System		p. 351

Menu command		Description	Setting range	Data	Reference		
Sensor settings	Data output	No-protocol data	When the communications type is RS-232C no-protocol				
			Baud rate	Set the baud rate to use for RS-232C communications.	2400, 4800, 9600, 19200, 38400, 57600, or 115200 (default: 38400)	System	p. 394
			Data length	Sets the data length.	7bit or 8bit (default: 8bit)	System	p. 394
			Parity	Sets the parity.	None, Odd, Even (default: None)	System	p. 394
			Stop bit	Sets the number of stop bits.	1bit, 2bit (default: 1bit)	System	p. 394
			Flow control	Sets the controls for the flow of communications with the software.	None, Xon/Xoff (default: None)	System	p. 394
			Delimiter	Set the delimiter to add to the end of commands and responses.	CR, LF, or CR+LF (default:CR)	System	p. 394
			Interval timeout (text)	Timeout [s] Set the time in seconds to generate a timeout error.	1 to 120 s, 0: Not monitored. (default: 0 s)	System	p. 394
	Interval timeout(after Xoff reception)	Timeout [s] Set the time in seconds to generate a timeout error.	1 to 120 s, 0: Not monitored. (default: 0 s)	System	p. 394		
	Link data output	Communication type	Sets the communications type to use for EtherNet/IP or PLC Link outputs.	Invalid (default), PLC link (SYSMAC) PLC link (MELSEC), EtherNet/IP	System	p. 327	
		Area settings(Only when communications type is PLC Link)	Command Area type			p. 328	
Address				Set the first address of the command area.	0 to 99,999 (default: 0)	System	

Menu command				Description	Setting range	Data	Reference		
Sensor settings	Data output	Link data output	Area settings	Response	Area type	Sets the area to write execution results from the Sensor. Control outputs, command codes, response codes, and response data	CIO Area (CIO) (default), Work Area (WR), Holding Bit Area (HR), Auxiliary Bit Area (AR), DM Area (DM), EM Area (EM0 to EMC)	System	p. 328
				Address	Set the first address of the response area.	0 to 99999 (default: 100)	System		
			Output	Area type	Sets the area to write output data from measurements. Output data 0 to 31	CIO Area (CIO) (default) Work Area (WR) Holding Bit Area (HR) Auxiliary Bit Area (AR) DM Area (DM) EM Area (EM0) EM Area (EM1) : EM Area (EMC)	System	p. 328	
				Address	Set the first address of the output area .	0 to 99999 (default: 200)	System		
		Output hand-shake	Sets whether to establish an interlock with the PLC when data is output.	No (default) or Yes	System	p. 328			
		Retry details	Enables or disables retrying communications. This can be set only when the communications type is set to a PLC Link.	ON or OFF (default)	System	p. 328			
		Retry interval	Sets the interval for retrying communications. This setting is enabled only when [Retry details] is set to [ON]. This can be set only when the communications type is set to a PLC Link.	0 to 2,147,483,647 ms (default:10,000 ms)	System	p. 328			
		Max output data	Sets the upper limit of the number of output data to use for PLC Link outputs. Any output data that is beyond this value is discarded. This can be set only when the communications type is set to a PLC Link.	32 to 1024 (default: 256)	System	p. 328			
		Output data size	Sets the data size to output for EtherNet/IP output. If the data size that is set is exceeded, data will be output in more than one transfer. This can be set only when the communications type is set to EtherNet/IP.	32 bytes (default), 64 bytes, 128 bytes, or 256 bytes	System	p. 290			
		Connection mode	Sets the TPC connection mode.	TCP server (default) or TCP client	System	p. 328			
	Refreshing task period	Set the communications cycle for cyclic tag data link communications for the Vision Sensor.	4 to 10,000 ms (default:10 ms)	System	p. 290				
	Timeout	Sets the timeout time when handshaking is enabled.	0.1 to 120.0 s (default: 10 s)	System	p. 291				
	Data output period	Set the period for outputting measurement results. This parameter is displayed and can be set only when [Handshake setting] is set to [No].	2 to 5,000 ms (default: 40 ms)	System	p. 291				
	GATE signal ON period	Set the time to turn ON the GATE signal. This parameter is displayed and can be set only when [Handshake setting] is set to [No].	1.0 to 1,000.0 ms (default: 20.0 ms)	System	p. 291				
	Initialize				Initializes the Sensor settings and saved data.	---	---	p. 229	
	Restart				Restarts the Sensor.	---	---		
	Update				Updates the Sensor system to the most recent data.	---	---	p. 491	

Menu command		Description	Setting range	Data	Reference		
TF settings	Information	Used to check the Touch Finder information.	---	System	p. 230		
	Model	Used to check the Touch Finder model.	---		---		
	Version	Used to check the software version of the Touch Finder.	---		p. 230		
	MAC address	Used to check the MAC address of the Touch Finder.	---				
	 Memory state	Used to check the Touch Finder memory state.	---		p. 230		
Error history	View history	Displays a history of errors that have occurred in the Touch Finder.	---	System	p. 399		
	Delete history	Deletes the error history.					
Battery level		Used to check the battery level.	---	---	p. 230		
File format	Logging image file	File name prefix	You can set a character string to add to the beginning of the file name for logged data.	---	p. 211		
		Logging data file				File name prefix	
	Output format	Used to set the output format for output log data to a file.				---	p. 212
		Field separator				None, Comma (default), Tab, Space, Colon, Semicolon, CR, or CR+LF	---
		Decimal symbol				None, Point (default), or Comma	---
Record separator	None, Comma, Tab, Space, Colon, Semicolon, CR, or CR+LF (default)	---					
SD card	SD card information	Displays the capacity and remaining memory in the SD card.	---	---	p. 222		
	Format	Formats an SD card.	---	---	p. 222		
Startup display	Startup screen type	You can select the display to appear on the Touch Finder when more than one Sensor is connected.	Multi Sensor, NG sensor, Single sensor, Auto (default)	---	p. 206		
	Specify sensor	You can specify one Sensor to connect to the Touch Finder.	ON, OFF (default)	---	p. 225		
	Display pattern	Sets the display to use in Run Mode.	Graphic, Graphics + Details, All results/Region, Statistical data, Trend monitor, Histogram	System	p. 183, p. 225		
	Display update mode	Sets the image to update in Run Mode.	Latest image, Last NG image		p. 201		
LCD backlight	Brightness	Sets the brightness.	0 to 5	System	p. 202		
	ECO mode	Enables (ON) or disables (OFF) ECO Mode.	ON, OFF	System	p. 202		









Menu command	Description	Setting range	Data	Reference	
TF settings	Ethernet	---	System	p. 53	
	Specify sensor	You can set any of the Sensors for connection to the Touch Finder and register them.	0.0.0.0 to 223.255.255.254 (default: 0.0.0.0)	p. 204, p. 205	
	IP address setting	Sets the method to use to set IP addresses.	Auto (default), Fixed, DHCP	p. 53	
	IP address	Inputs the IP address of the Touch Finder. (Valid only when the [IP address setting] is set to [Fixed].)	a.b.c.d a:1 to 223 b: 0 to 255 c: 0 to 255 d: 0 to 255 (Default: 10.5.5.100)	p. 53	
	Subnet mask	Inputs the subnet mask. (Valid only when the [IP address setting] is set to [Fixed].)	0.0.0.0 to 255.255.255.255 (Default: 255.255.255.0)	p. 53	
	Gateway	Sets the default gateway address. (When the [IP address setting] is set to [Fixed].)	1.0.0.1 to 223.255.255.254 (Default: 10.5.5.7)		
	Search unreachable sensors	Displays the IP address if the same IP address is used for more than one Sensor or if there is Sensor that is not in the subnet. You can change this IP address and subnet mask. This setting is valid only when automatic setting of the Sensor's IP address is OFF.	---	---	---
	Auto sensor detection	The Touch Finder can detect Sensors and automatically connect to them in the order that it detects them.	ON (default), OFF		p. 204
	Logging setting	You must enable file logging before you can execute it.	ON (default), OFF		p. 212
	Language	Changes the language to display on the Touch Finder.	English, German, French, Italian, Spanish, Traditional Chinese, Simplified Chinese, Korean, or Japanese (The default language is selected at startup.)	System	p. 229
	Time settings	Used to set the current date and time.	Default: Selected at startup.	System	p. 229
	Touch screen calib	Used when there is an offset between the touch screen positions and pointers.	---	---	p. 230
Initialize	Initializes the Touch Finder settings.	---	---	p. 229	
Restart	Restarts the Touch Finder.	---	---	p. 229	
Update	Updates the Touch Finder system to the most recent data.	---	---	p. 491	

## Run Mode

Menu command		Description	Setting range	Data	Reference	
Select display	Graphic	Displays the input image.	---	---	p. 182	
	Graphics + Details	Displays the inspection item individual judgement results and measurement values.		---		
	Statistical data	Displays the total number of measurements and the total number of NG overall judgements and the NG ratio from when the power supply was turned ON.		---		
	All results/Region	Displays the inspection item individual judgement results for all inspection items.		---		
	Trend Monitor	Displays the individual judgement results saved in the Sensor in a trend monitor.		---		p. 184
	Histogram	Displays the individual judgement results saved in the Sensor in a histogram.		---		p. 185
	Model region	Changes to Setup Mode and changes the output form for measurement values.		---		
	Insp. region	Changes to Setup Mode and changes the parameters for judgement conditions.		---		
	 Adjust judgement (Except for statistical data)	Adjusts judgement parameters without stopping measurements.	---	---	p. 187	
	Auto display (trend monitor and histogram only)	Automatically sets the display range according to the measurement results.	OFF or ON (default)	---	p. 184, p. 185	
Display range (trend monitor and histogram only)	Changes the display range of measurement values.	-999,999,999 to 999,999,999	---	p. 184, p. 185		
Number of data (trend monitor only)	Changes the number of displayed measurement values.	200, 400, or 1,000 (default: 200)	---	p. 184		
Number of data (histogram only)	Changes the number of displayed measurement values (i.e., the vertical display range of the histogram).	5 to 1,000	---	p. 185		
Clear results (graphic or graphic + details list)	Clears the measurement results of the inspection items.	---	---	---		
Clear results	Clears the total results of the inspection items.	---	---	---		
Delete stats (total data)	Clears the Statistical data.	---	---	---		
Logging	Image logging	Starts and stops logging in external memory.	ON: Start or OFF: Stop	---	p. 213	
	Data logging		ON: Start or OFF: Stop	---		
TF settings		The same as for Setup Mode. (This does not apply to the PC Tool.) The resolution of the measurement image can be set on the PC Tool.			p. 229	
Sensor setting		Switches to Setup Mode.	---	---	p. 180	
Sensor monitor	Multi sensor	Simultaneously displays the images for multiple connected Sensors.	---	---	p. 183	
	NG sensor	From multiple connected Sensors, displays the image of only the Sensors with NG results.	---	---		

Menu command		Description	Setting range	Data	Reference
Switch sensor	Select	Switches to the selected Sensor.	---	---	p. 58
	Connections	Displays the name of the Sensor detected by the Touch Finder and the connection status.		---	
	 Auto connect	Automatically detects and connects the Sensors that are connected.		---	

## Common Menu Commands

Menu command		Description	Setting range	Data	Reference
	Only-image Button	Hides text and displays only the image.	---	---	p. 202
Display Button	 Zoom-in Button	Enlarges the image display.	---	---	p. 200
	 Zoom-out Button	Reduces the image display.			
	 FIT Button	Fits the image to the display size.			
	 Display Button	Changes the image display method.	Setup Mode: Camera (Live, Freeze) Log, Logging image file or Camera image file Run Mode: Latest image or Last NG image	---	
	 Log Image Button	You can save the Camera image that is displayed on the Touch Finder or computer.	---	---	p. 201
	Capture Button	Used to capture the current display and save it in external memory, e.g., an SD card.	---	---	p. 224

# 12-2 External Reference Parameters

## Color Gray Filter

External reference number	Category	Data name	Setting/Acquisition	Data range	Default	Expression text string	Logged data/Judgement parameter
0	Measurement result	Judgement	Acquisition only	-2: No judgement (not measured), 0: Judgement is OK, -1: Judgement is NG, -13: Teaching not performed error, -14: Figure not registered error, -15: Out of range error	-2	JG	---
120	Measurement conditions	Source image	Setting/Acquisition	0: Camera image, 1: Previous image	1	---	---
121		Setting method	Setting/Acquisition	0: Filtering OFF, 1: Filtering ON	1	---	---
122		Filter type	Setting/Acquisition	Filter type 0: RGB 1: HSV	0	---	---
123		Color filter type	Setting/Acquisition	Color Filter Type 0: Red filter, 1: Green filter, 2: Blue filter, 3: Cyan filter, 4: Magenta filter, 5: Yellow filter, 6: Gray filter (R+G+B), 7: Gray filter (R+2G+B), 8: Gray filter (user-set),	0	---	---
124		Color gray filter type	Setting/Acquisition	Color Gray Filter Type 0: High speed, 1: High precision	1	---	---
125		RGB gain R	Setting/Acquisition	0.0001 to 9.9999	0.3	---	---
126		RGB gain G	Setting/Acquisition	0.0001 to 9.9999	0.59	---	---
127		RGB gain B	Setting/Acquisition	0.0001 to 9.9999	0.11	---	---
128		Standard hue	Setting/Acquisition	0 to 359	0	---	---
129		Hue range	Setting/Acquisition	10 to 180	90	---	---
130	Chroma upper limit	Setting/Acquisition	0 to 255	255	---	---	
131	Chroma lower limit	Setting/Acquisition	0 to 255	0	---	---	

## Weak Smoothing

External reference number	Category	Data name	Setting/Acquisition	Data range	Default	Expression text string	Logged data/Judgement parameter
0	Measurement result	Judgement	Acquisition only	-2: No judgement (not measured), 0: Judgement is OK, -1: Judgement is NG, -13: Teaching not performed error, -14: Figure not registered error, -15: Out of range error	-2	JG	---
120	Measurement conditions	Source image	Setting/Acquisition	0: Camera image, 1: Previous image	1	---	---
121	Measurement conditions	Setting method	Setting/Acquisition	0: Filtering OFF, 1: Filtering ON	1	---	---

## Strong Smoothing

External reference number	Category	Data name	Setting/Acquisition	Data range	Default	Expression text string	Logged data/Judgement parameter
0	Measurement result	Judgement	Acquisition only	-2: No judgement (not measured), 0: Judgement is OK, -1: Judgement is NG, -13: Teaching not performed error, -14: Figure not registered error, -15: Out of range error	-2	JG	---
120	Measurement conditions	Source image	Setting/Acquisition	0: Camera image, 1: Previous image	1	---	---
121	Measurement conditions	Setting method	Setting/Acquisition	0: Filtering OFF, 1: Filtering ON	1	---	---

## Dilate

External reference number	Category	Data name	Setting/Acquisition	Data range	Default	Expression text string	Logged data/Judgement parameter
0	Measurement result	Judgement	Acquisition only	-2: No judgement (not measured), 0: Judgement is OK, -1: Judgement is NG, -13: Teaching not performed error, -14: Figure not registered error, -15: Out of range error	-2	JG	---
120	Measurement conditions	Source image	Setting/Acquisition	0: Camera image, 1: Previous image	1	---	---
121	Measurement conditions	Setting method	Setting/Acquisition	0: Filtering OFF, 1: Filtering ON	1	---	---

## Erosion, Median, Extract Edges, Extract Horizontal Edges, Extract

### Vertical Edges, Enhance edges

External reference number	Category	Data name	Setting/Acquisition	Data range	Default	Expression text string	Logged data/Judgement parameter
0	Measurement result	Judgement	Acquisition only	-2: No judgement (not measured), 0: Judgement is OK, -1: Judgement is NG, -13: Teaching not performed error, -14: Figure not registered error, -15: Out of range error	-2	JG	---
120	Measurement	Source image	Setting/Acquisition	0: Camera image, 1: Previous image	1	---	---
121	Measurement conditions	Setting method	Setting/Acquisition	0: Filtering OFF, 1: Filtering ON	1	---	---

### Background Suppression

External reference number	Category	Data name	Setting/Acquisition	Data range	Default	Expression text string	Logged data/Judgement parameter
0	Measurement result	Judgement	Acquisition only	-2: No judgement (not measured), 0: Judgement is OK, -1: Judgement is NG, -13: Teaching not performed error, -14: Figure not registered error, -15: Out of range error	-2	JG	---

External reference number	Category	Data name	Setting/Acquisition	Data range	Default	Expression text string	Logged data/Judgement parameter
120	Measurement conditions	Source image	Setting/Acquisition	0: Camera image, 1: Previous image	1	---	---
121		Setting method	Setting/Acquisition	0: Filtering OFF, 1: Filtering ON	1	---	---
122		Image format	Setting/Acquisition	0: Binary image, 1: Monochrome image, 2: Color image	0	---	---
123		Color setting mode	Setting/Acquisition	0: RGB common, 1: RGB individual	0	---	---
124		Common color lower limit	Setting/Acquisition	0 to 255	0	---	---
125		Common color upper limit	Setting/Acquisition	0 to 255	255	---	---
126		R lower limit	Setting/Acquisition	0 to 255	0	---	---
127		R upper limit	Setting/Acquisition	0 to 255	255	---	---
128		G lower limit	Setting/Acquisition	0 to 255	0	---	---
129		G upper limit	Setting/Acquisition	0 to 255	255	---	---
130		B lower limit	Setting/Acquisition	0 to 255	0	---	---
131		B upper limit	Setting/Acquisition	0 to 255	255	---	---
132		Grayscale lower limit	Setting/Acquisition	0 to 255	0	---	---
133		Grayscale upper limit	Setting/Acquisition	0 to 255	255	---	---

## Shape Search II Position Compensation

External reference number	Category	Data name	Setting/Acquisition	Data range	Default	Expression text string	Logged data/Judgement parameter	
0	Measurement result	Judgement	Acquisition only	-2: No judgement (not measured), 0: Judgement is OK, -1: Judgement is NG, -13: Teaching not performed error, -14: Figure not registered error, -15: Out of range error	-2	JG	Logged data	
5		Scroll X	Acquisition only	X compensation amount	0	DX	Logged data	
6		Scroll Y	Acquisition only	Y compensation amount	0	DY	Logged data	
7		Scroll $\theta$	Acquisition only	Rotational compensation amount	0	DT	Logged data	
8		Position X	Acquisition only	Measurement value X coordinate	0	X	Logged data	
9		Position Y	Acquisition only	Measurement value Y coordinate	0	Y	Logged data	
10		Angle	Acquisition only	Measurement angle	0	TH	Logged data	
11		Reference X	Acquisition only	0 to 9,999	0	SX	Logged data	
12		Reference Y	Acquisition only	0 to 9,999	0	SY	Logged data	
13		Reference angle	Acquisition only	-180 to 180	0	ST	Logged data	
14		Correlation	Acquisition only	0 to 100	0	CR	Logged data	
120		Measurement conditions	Position compensation precision	Setting/Acquisition	0: None, 1: Bilinear	0	---	---
121			Setting method	Setting/Acquisition	0: Cancel position compensation, 1: Position compensation based on internal search	1	---	---
122			Position compensation image	Setting/Acquisition	0: Camera image, 1: Previous image	1	---	---
123	Model region	Rotation	Setting/Acquisition	0: No rotation 1: Rotation	1	---	---	
124		Reference X	Setting/Acquisition	0 to 9,999	0	---	---	
125		Reference Y	Setting/Acquisition	0 to 9,999	0	---	---	
126		Reference angle	Setting/Acquisition	-180 to 180	0	---	---	
140		Rotation angle upper limit	Setting/Acquisition	-180 to 180	180	---	---	
141		Rotation angle lower limit	Setting/Acquisition	-180 to 180	-180	---	---	
149	Measurement condition	Candidate level	Setting/Acquisition	0 to 100	60	---	---	



External reference number	Category	Data name	Setting/Acquisition	Data range	Default	Expression text string	Logged data/Judgement parameter
150	Detection point coordinate	Detection point X	Setting/Acquisition	0 to 9,999	0	---	---
151		Detection point Y	Setting/Acquisition	0 to 9,999	0	---	---
156	Measurement condition	Model mode	Setting/Acquisition	0: Stable, 1: High-speed	0	---	---
160	Judgement conditions	Judgement upper limit for search coordinate X	Setting/Acquisition	-99,999.9999 to 99,999.9999	99,999.9999	---	Adjust judgement
161		Judgement lower limit for search coordinate X	Setting/Acquisition	-99,999.9999 to 99,999.9999	-99,999.9999	---	Adjust judgement
162		Judgement upper limit for search coordinate Y	Setting/Acquisition	-99,999.9999 to 99,999.9999	99,999.9999	---	Adjust judgement
163		Judgement lower limit for search coordinate Y	Setting/Acquisition	-99,999.9999 to 99,999.9999	-99,999.9999	---	Adjust judgement
164		Judgement upper limit for search angle	Setting/Acquisition	-180 to 180	180	---	Adjust judgement
165		Judgement lower limit for search angle	Setting/Acquisition	-180 to 180	-180	---	Adjust judgement
166		Judgement upper limit for correlation	Setting/Acquisition	0 to 100	100	---	Adjust judgement
167		Judgement lower limit for correlation	Setting/Acquisition	0 to 100	60	---	Adjust judgement
168		Position compensation X upper limit	Setting/Acquisition	-99,999.9999 to 99,999.9999	99,999.9999	---	Adjust judgement
169		Position compensation X lower limit	Setting/Acquisition	-99,999.9999 to 99,999.9999	-99,999.9999	---	Adjust judgement
170	Position compensation Y upper limit	Setting/Acquisition	-99,999.9999 to 99,999.9999	99,999.9999	---	Adjust judgement	
171	Position compensation Y lower limit	Setting/Acquisition	-99,999.9999 to 99,999.9999	-99,999.9999	---	Adjust judgement	
172	Theta position compensation upper limit	Setting/Acquisition	-180 to 180	180	---	Adjust judgement	
173	Theta position compensation lower limit	Setting/Acquisition	-180 to 180	-180	---	Adjust judgement	
310	Logging conditions	Data logging switch for entire unit	Setting/Acquisition	0: Data logging OFF, 1: Data logging ON	0	---	---
311		Data logging switch for judgement	Setting/Acquisition	0: Data logging OFF, 1: Data logging ON	0	---	---
312		Data logging switch for scroll X	Setting/Acquisition	0: Data logging OFF, 1: Data logging ON	0	---	---
313		Data logging switch for scroll Y	Setting/Acquisition	0: Data logging OFF, 1: Data logging ON	0	---	---
315		Data logging switch for position X	Setting/Acquisition	0: Data logging OFF, 1: Data logging ON	0	---	---
316		Data logging switch for position Y	Setting/Acquisition	0: Data logging OFF, 1: Data logging ON	0	---	---
321		Data logging switch for correlation	Setting/Acquisition	0: Data logging OFF, 1: Data logging ON	0	---	---

External reference number	Category	Data name	Setting/Acquisition	Data range	Default	Expression text string	Logged data/Judgement parameter
700	Display settings	Position compensation X display	Setting/Acquisition	0: Display, 1: Do not display	0	---	---
701		Position compensation Y display	Setting/Acquisition	0: Display, 1: Do not display	0	---	---
702		Theta position compensation display	Setting/Acquisition	0: Display, 1: Do not display	0	---	---
703		Correlation display	Setting/Acquisition	0: Display, 1: Do not display	0	---	---
704		Position X display	Setting/Acquisition	0: Display, 1: Do not display	0	---	---
705		Position Y display	Setting/Acquisition	0: Display, 1: Do not display	0	---	---
706		Measurement angle display	Setting/Acquisition	0: Display, 1: Do not display	0	---	---

## Search Position Compensation

External reference number	Category	Data name	Setting/Acquisition	Data range	Default	Expression text string	Logged data/Judgement parameter
0	Measurement result	Judgement	Acquisition only	-2: No judgement (not measured), 0: Judgement is OK, -1: Judgement is NG, -13: Teaching not performed error, -14: Figure not registered error, -15: Out of range error	-2	JG	Logged data
5		Scroll X	Acquisition only	-99,999.9999 to 99,999.9999	0	DX	Logged data
6		Scroll Y	Acquisition only	-99,999.9999 to 99,999.9999	0	DY	Logged data
8		Position X	Acquisition only	-99,999.9999 to 99,999.9999	0	X	Logged data
9		Position Y	Acquisition only	-99,999.9999 to 99,999.9999	0	Y	Logged data
11		Reference X	Acquisition only	-99,999.9999 to 99,999.9999	0	SX	Logged data
12		Reference Y	Acquisition only	-99,999.9999 to 99,999.9999	0	SY	Logged data
14		Correlation	Acquisition only	0 to 100	0	CR	Logged data
103	Output parameter	Reflect	Setting/Acquisition	0: Yes, 1: No	0	---	---
120	Measurement conditions	Position compensation precision	Setting/Acquisition	0: None, 1: Bilinear	0	---	---
122		Position compensation image	Setting/Acquisition	0: Camera image, 1: Previous image	0	---	---

External reference number	Category	Data name	Setting/Acquisition	Data range	Default	Expression text string	Logged data/Judgement parameter
124	Model region	Reference X	Setting/Acquisition	0 to 99,999.9999	0	---	---
125		Reference Y	Setting/Acquisition	0 to 99,999.9999	0	---	---
145	Detection coordinate	Detection point X	Setting/Acquisition	0 to 9,999	0	---	---
146		Detection point Y	Setting/Acquisition	0 to 9,999	0	---	---
147	Measurement conditions	Sub-pixel	Setting/Acquisition	0: No, 1: Yes	0	---	---
148		Candidate level	Setting/Acquisition	0 to 100	70	---	---
166	Judgement conditions	Judgement upper limit for correlation	Setting/Acquisition	0 to 100	100	---	Adjust judgement
167		Judgement lower limit for correlation	Setting/Acquisition	0 to 100	60		
310	Logging conditions	Data logging switch for entire unit	Setting/Acquisition	0: Data logging OFF, 1: Data logging ON	0	---	---
311		Data logging switch for judgement	Setting/Acquisition	0: Data logging OFF, 1: Data logging ON	0	---	---
312		Data logging switch for scroll X	Setting/Acquisition	0: Data logging OFF, 1: Data logging ON	0	---	---
313		Data logging switch for scroll Y	Setting/Acquisition	0: Data logging OFF, 1: Data logging ON	0	---	---
315		Data logging switch for position X	Setting/Acquisition	0: Data logging OFF, 1: Data logging ON	0	---	---
316		Data logging switch for position Y	Setting/Acquisition	0: Data logging OFF, 1: Data logging ON	0	---	---
321		Data logging switch for correlation	Setting/Acquisition	0: Data logging OFF, 1: Data logging ON	0	---	---
700	Display settings	Position compensation X display	Setting/Acquisition	0: Display, 1: Do not display	0	---	---
701		Position compensation Y display	Setting/Acquisition	0: Display, 1: Do not display	0	---	---
702		Correlation display	Setting/Acquisition	0: Display, 1: Do not display	0	---	---
703		Position X display	Setting/Acquisition	0: Display, 1: Do not display	0	---	---
704		Position Y display	Setting/Acquisition	0: Display, 1: Do not display	0	---	---

## Edge Position Compensation

External reference number	Category	Data name	Setting/Acquisition	Data range	Default	Expression text string	Logged data/Judgement parameter
0	Measurement result	Judgement	Acquisition only	-2: No judgement (not measured), 0: Judgement is OK, -1: Judgement is NG, -13: Teaching not performed error, -14: Figure not registered error, -15: Out of range error	-2	JG	Logged data
5		Scroll X	Acquisition only	-99,999.9999 to 99,999.9999	0	DX	Logged data
6		Scroll Y	Acquisition only	-99,999.9999 to 99,999.9999	0	DY	Logged data
7		Edge position X	Acquisition only	-99,999.9999 to 99,999.9999	0	X	Logged data
8		Edge position Y	Acquisition only	-99,999.9999 to 99,999.9999	0	Y	Logged data
9		Standard position X	Acquisition only	-99,999.9999 to 99,999.9999	0	SX	Logged data
10		Standard position Y	Acquisition only	-99,999.9999 to 99,999.9999	0	SY	Logged data
103	Output parameter	Reflect	Setting/Acquisition	0: Yes, 1: No	0	---	---

External reference number	Category	Data name	Setting/Acquisition	Data range	Default	Expression text string	Logged data/Judgement parameter
120	Measurement conditions	Position compensation precision	Setting/Acquisition	0: None, 1: Bilinear	0	---	---
121		Setting method	Setting/Acquisition	0: Cancel position compensation, 1: Position compensation based on internal edge position measurement	1	---	---
122		Position compensation image	Setting/Acquisition	0: Camera image, 1: Previous image	0	---	---
140		Set color	Setting/Acquisition	0: No edge color specification, 1: Edge color specification	0	---	---
141		Edge color red	Setting/Acquisition	0 to 255	255	---	---
142		Edge color green	Setting/Acquisition	0 to 255	255	---	---
143		Edge color blue	Setting/Acquisition	0 to 255	255	---	---
147		Detection mode	Setting/Acquisition	0: Color IN, 1: Color OUT	0	---	---
149		Edge level	Setting/Acquisition	0 to 100	50	---	---
150		Noise level	Setting/Acquisition	0 to 442	5	---	---
153		Monochrome density change	Setting/Acquisition	(Monochrome Cameras) 0: Light to Dark, 1: Dark to Light	0	---	---
157		Measurement method	Setting/Acquisition	(Monochrome Cameras) 0: Projection, 1: Differentiation	0	---	---
180		Judgement conditions	Edge position X upper limit	Setting/Acquisition	-99,999.9999 to 99,999.9999	99,999.9999	---
181	Edge position X lower limit		Setting/Acquisition	-99,999.9999 to 99,999.9999	-99,999.9999	---	Adjust judgement
182	Edge position Y upper limit		Setting/Acquisition	-99,999.9999 to 99,999.9999	99,999.9999	---	Adjust judgement
183	Edge position Y lower limit		Setting/Acquisition	-99,999.9999 to 99,999.9999	-99,999.9999	---	Adjust judgement
184	Position compensation X upper limit		Setting/Acquisition	-99,999.9999 to 99,999.9999	99,999.9999	---	Adjust judgement
185	Position compensation X lower limit		Setting/Acquisition	-99,999.9999 to 99,999.9999	-99,999.9999	---	Adjust judgement
186	Position compensation Y upper limit		Setting/Acquisition	-99,999.9999 to 99,999.9999	99,999.9999	---	Adjust judgement
187	Position compensation Y lower limit		Setting/Acquisition	-99,999.9999 to 99,999.9999	-99,999.9999	---	Adjust judgement

External reference number	Category	Data name	Setting/Acquisition	Data range	Default	Expression text string	Logged data/Judgement parameter
310	Logging conditions	Data logging switch for entire unit	Setting/Acquisition	0: Data logging OFF, 1: Data logging ON	0	---	---
311		Data logging switch for judgement	Setting/Acquisition	0: Data logging OFF, 1: Data logging ON	0	---	---
312		Data logging switch for scroll X	Setting/Acquisition	0: Data logging OFF, 1: Data logging ON	0	---	---
313		Data logging switch for scroll Y	Setting/Acquisition	0: Data logging OFF, 1: Data logging ON	0	---	---
314		Data logging switch for detected edge position X	Setting/Acquisition	0: Data logging OFF, 1: Data logging ON	0	---	---
315		Data logging switch for detected edge position Y	Setting/Acquisition	0: Data logging OFF, 1: Data logging ON	0	---	---
700	Display settings	Position compensation X display	Setting/Acquisition	Position compensation X display 0: ON, 1: OFF	0	---	---
701		Position compensation Y display	Setting/Acquisition	Position compensation Y display 0: ON, 1: OFF	0	---	---
702		Detected edge position X display	Setting/Acquisition	Detected edge position X display 0: ON, 1: OFF	0	---	---
703		Detected edge position Y display	Setting/Acquisition	Detected edge position Y display 0: ON, 1: OFF	0	---	---

## Two-edge Position Compensation

External reference number	Category	Data name	Setting/Acquisition	Data range	Default	Expression text string	Logged data/Judgement parameter
0	Measurement result	Judgement	Acquisition only	-2: No judgement (not measured), 0: Judgement is OK, -1: Judgement is NG, -13: Teaching not performed error, -14: Figure not registered error, -15: Out of range error	-2	JG	Logged data
5		Scroll X	Acquisition only	-99,999.9999 to 99,999.9999	0	DX	Logged data
6		Scroll Y	Acquisition only	-99,999.9999 to 99,999.9999	0	DY	Logged data
7		Detected edge position X0	Acquisition only	-99,999.9999 to 99,999.9999	0	X0	Logged data
8		Detected edge position Y0	Acquisition only	-99,999.9999 to 99,999.9999	0	Y0	Logged data
9		Detected edge position X1	Acquisition only	-99,999.9999 to 99,999.9999	0	X1	Logged data
10		Detected edge position Y1	Acquisition only	-99,999.9999 to 99,999.9999	0	Y1	Logged data
11		Standard position X0	Acquisition only	-99,999.9999 to 99,999.9999	0	SX0	Logged data
12		Standard position Y0	Acquisition only	-99,999.9999 to 99,999.9999	0	SY0	Logged data
13		Standard position X1	Acquisition only	-99,999.9999 to 99,999.9999	0	SX1	Logged data
14	Standard position Y1	Acquisition only	-99,999.9999 to 99,999.9999	0	SY1	Logged data	
103	Output parameter	Reflect	Setting/Acquisition	0: Yes, 1: No	0	---	---

External reference number	Category	Data name	Setting/Acquisition	Data range	Default	Expression text string	Logged data/Judgement parameter
120	Measurement conditions	Position compensation precision	Setting/Acquisition	0: None, 1: Bilinear	0	---	---
121		Setting method	Setting/Acquisition	0: Cancel position compensation, 1: Position compensation based on internal edge position measurement	1	---	---
122		Position compensation image	Setting/Acquisition	0: Camera image, 1: Previous image	0	---	---
140		Edge color specification 0	Setting/Acquisition	0: No edge color specification, 1: Edge color specification	0	---	---
141		Edge color R0	Setting/Acquisition	0 to 255	255	---	---
142		Edge color G0	Setting/Acquisition	0 to 255	255	---	---
143		Edge color B0	Setting/Acquisition	0 to 255	255	---	---
147		Density change 0	Setting/Acquisition	0: Color IN, 1: Color OUT	0	---	---
149		Edge level 0	Setting/Acquisition	0 to 100	50	---	---
150		Noise level 0	Setting/Acquisition	0 to 442	5	---	---
153		Monochrome density change 0	Setting/Acquisition	(Monochrome Cameras) 0: Light to Dark, 1: Dark to Light	0	---	---
157		Measurement method 0	Setting/Acquisition	(Monochrome Cameras) 0: Projection, 1: Differentiation	0	---	---
160		Edge color specification 1	Setting/Acquisition	0: No edge color specification, 1: Edge color specification	0	---	---
161		Edge color R1	Setting/Acquisition	0 to 255	255	---	---
162		Edge color G1	Setting/Acquisition	0 to 255	255	---	---
163		Edge color B1	Setting/Acquisition	0 to 255	255	---	---
167		Density change 1	Setting/Acquisition	0: Color IN, 1: Color OUT	0	---	---
169		Edge level 1	Setting/Acquisition	0 to 100	50	---	---
170		Noise level 1	Setting/Acquisition	0 to 442	5	---	---
173		Monochrome density change 1	Setting/Acquisition	(Monochrome Cameras) 0: Light to Dark, 1: Dark to Light	0	---	---
177	Measurement method 1	Setting/Acquisition	(Monochrome Cameras) 0: Projection, 1: Differentiation	0	---	---	



External reference number	Category	Data name	Setting/Acquisition	Data range	Default	Expression text string	Logged data/Judgement parameter	
180	Judgement conditions	Edge position X upper limit 0	Setting/Acquisition	-99,999.9999 to 99,999.9999	99,999.9999	---	Adjust judgement	
181		Edge position X lower limit 0	Setting/Acquisition	-99,999.9999 to 99,999.9999	-99,999.9999	---	Adjust judgement	
182		Edge position Y upper limit 0	Setting/Acquisition	-99,999.9999 to 99,999.9999	99,999.9999	---	Adjust judgement	
183		Edge position Y lower limit 0	Setting/Acquisition	-99,999.9999 to 99,999.9999	-99,999.9999	---	Adjust judgement	
185		Edge position X upper limit 1	Setting/Acquisition	-99,999.9999 to 99,999.9999	99,999.9999	---	Adjust judgement	
186		Edge position X lower limit 1	Setting/Acquisition	-99,999.9999 to 99,999.9999	-99,999.9999	---	Adjust judgement	
187		Edge position Y upper limit 1	Setting/Acquisition	-99,999.9999 to 99,999.9999	99,999.9999	---	Adjust judgement	
188		Edge position Y lower limit 1	Setting/Acquisition	-99,999.9999 to 99,999.9999	-99,999.9999	---	Adjust judgement	
190		Position compensation X upper limit	Setting/Acquisition	-99,999.9999 to 99,999.9999	99,999.9999	---	Adjust judgement	
191		Position compensation X lower limit	Setting/Acquisition	-99,999.9999 to 99,999.9999	-99,999.9999	---	Adjust judgement	
192		Position compensation Y upper limit	Setting/Acquisition	-99,999.9999 to 99,999.9999	99,999.9999	---	Adjust judgement	
193		Position compensation Y lower limit	Setting/Acquisition	-99,999.9999 to 99,999.9999	-99,999.9999	---	Adjust judgement	
310		Logging conditions	Data logging switch for entire unit	Setting/Acquisition	0: Data logging OFF, 1: Data logging ON	0	---	---
311			Data logging switch for judgement	Setting/Acquisition	0: Data logging OFF, 1: Data logging ON	0	---	---
312	Data logging switch for scroll X		Setting/Acquisition	0: Data logging OFF, 1: Data logging ON	0	---	---	
313	Data logging switch for scroll Y		Setting/Acquisition	0: Data logging OFF, 1: Data logging ON	0	---	---	
314	Data logging switch for detected edge position X0		Setting/Acquisition	0: Data logging OFF, 1: Data logging ON	0	---	---	
315	Data logging switch for detected edge position Y0		Setting/Acquisition	0: Data logging OFF, 1: Data logging ON	0	---	---	
316	Data logging switch for detected edge position X1		Setting/Acquisition	0: Data logging OFF, 1: Data logging ON	0	---	---	
317	Data logging switch for detected edge position Y1		Setting/Acquisition	0: Data logging OFF, 1: Data logging ON	0	---	---	

External reference number	Category	Data name	Setting/Acquisition	Data range	Default	Expression text string	Logged data/Judgement parameter
700	Display settings	Position compensation X display	Setting/Acquisition	0: ON, 1: OFF	0	---	---
701		Position compensation Y display	Setting/Acquisition	0: ON, 1: OFF	0	---	---
702		Detected edge position X0 display	Setting/Acquisition	0: ON, 1: OFF	0	---	---
703		Detected edge position Y0 display	Setting/Acquisition	0: ON, 1: OFF	0	---	---
704		Detected edge position X1 display	Setting/Acquisition	0: ON, 1: OFF	0	---	---
705		Detected edge position Y1 display	Setting/Acquisition	0: ON, 1: OFF	0	---	---

## Two-edge Midpoint Compensation

External reference number	Category	Data name	Setting/Acquisition	Data range	Default	Expression text string	Logged data/Judgement parameter
0	Measurement result	Judgement	Acquisition only	-2: No judgement (not measured), 0: Judgement is OK, -1: Judgement is NG, -13: Teaching not performed error, -14: Figure not registered error, -15: Out of range error	-2	JG	Logged data
5		Scroll X	Acquisition only	-99,999.9999 to 99,999.9999	0	DX	Logged data
6		Scroll Y	Acquisition only	-99,999.9999 to 99,999.9999	0	DY	Logged data
7		Detected edge position X0	Acquisition only	-99,999.9999 to 99,999.9999	0	X0	Logged data
8		Detected edge position Y0	Acquisition only	-99,999.9999 to 99,999.9999	0	Y0	Logged data
9		Detected edge position X1	Acquisition only	-99,999.9999 to 99,999.9999	0	X1	Logged data
10		Detected edge position Y1	Acquisition only	-99,999.9999 to 99,999.9999	0	Y1	Logged data
11		Detected edge midpoint position X	Acquisition only	-99,999.9999 to 99,999.9999	0	MX	Logged data
12		Detected edge midpoint position Y	Acquisition only	-99,999.9999 to 99,999.9999	0	MY	Logged data
13		Standard position X0	Acquisition only	-99,999.9999 to 99,999.9999	0	SX0	Logged data
14		Standard position Y0	Acquisition only	-99,999.9999 to 99,999.9999	0	SY0	Logged data

External reference number	Category	Data name	Setting/Acquisition	Data range	Default	Expression text string	Logged data/Judgement parameter
15	Measurement result	Standard position X1	Acquisition only	-99,999.9999 to 99,999.9999	0	SX1	Logged data
16		Standard position Y1	Acquisition only	-99,999.9999 to 99,999.9999	0	SY1	Logged data
17		Standard midpoint position X	Acquisition only	-99,999.9999 to 99,999.9999	0	SMX	Logged data
18		Standard midpoint position Y	Acquisition only	-99,999.9999 to 99,999.9999	0	SMY	Logged data
103	Output parameter	Reflect	Setting/Acquisition	0: Yes, 1: No	0	---	---
120	Measurement conditions	Position compensation precision	Setting/Acquisition	0: None, 1: Bilinear	0	---	---
121		Setting method	Setting/Acquisition	0: Cancel position compensation, 1: Position compensation based on internal edge position measurement	1	---	---
122		Position compensation image	Setting/Acquisition	0: Camera image, 1: Previous image	0	---	---
140		Edge color specification 0	Setting/Acquisition	0: No edge color specification, 1: Edge color specification	0	---	---
141		Edge color R0	Setting/Acquisition	0 to 255	255	---	---
142		Edge color G0	Setting/Acquisition	0 to 255	255	---	---
143		Edge color B0	Setting/Acquisition	0 to 255	255	---	---
147		Density change 0	Setting/Acquisition	0: Color IN, 1: Color OUT	0	---	---
149		Edge level 0	Setting/Acquisition	0 to 100(Monochrome Cameras)	50	---	---
150		Noise level 0	Setting/Acquisition	0 to 442	5	---	---
153		Monochrome density change 0	Setting/Acquisition	(Monochrome Cameras) 0: Light to Dark, 1: Dark to Light	0	---	---
157		Measurement method 0	Setting/Acquisition	(Monochrome Cameras) 0: Projection, 1: Differentiation	0	---	---
160		Edge color specification 1	Setting/Acquisition	0: No edge color specification, 1: Edge color specification	0	---	---
161		Edge color R1	Setting/Acquisition	0 to 255	255	---	---
162	Edge color G1	Setting/Acquisition	0 to 255	255	---	---	
163	Edge color B1	Setting/Acquisition	0 to 255	255	---	---	
167	Density change 1	Setting/Acquisition	0: Color IN, 1: Color OUT	0	---	---	
169	Edge level 1	Setting/Acquisition	0 to 100	50	---	---	

External reference number	Category	Data name	Setting/Acquisition	Data range	Default	Expression text string	Logged data/Judgement parameter
170	Measurement conditions	Noise level 1	Setting/Acquisition	0 to 442	5	---	---
173		Monochrome density change 1	Setting/Acquisition	(Monochrome Cameras) 0: Light to Dark, 1: Dark to Light	0	---	---
177		Measurement method 1	Setting/Acquisition	(Monochrome Cameras) 0: Projection, 1: Differentiation	0	---	---
180	Judgement conditions	Edge position X upper limit 0	Setting/Acquisition	-99,999.9999 to 99,999.9999	99,999.9999	---	Adjust judgement
181		Edge position X lower limit 0	Setting/Acquisition	-99,999.9999 to 99,999.9999	-99,999.9999	---	Adjust judgement
182		Edge position Y upper limit 0	Setting/Acquisition	-99,999.9999 to 99,999.9999	99,999.9999	---	Adjust judgement
183		Edge position Y lower limit 0	Setting/Acquisition	-99,999.9999 to 99,999.9999	-99,999.9999	---	Adjust judgement
185		Edge position X upper limit 1	Setting/Acquisition	-99,999.9999 to 99,999.9999	99,999.9999	---	Adjust judgement
186		Edge position X lower limit 1	Setting/Acquisition	-99,999.9999 to 99,999.9999	-99,999.9999	---	Adjust judgement
187		Edge position Y upper limit 1	Setting/Acquisition	-99,999.9999 to 99,999.9999	99,999.9999	---	Adjust judgement
188		Edge position Y lower limit 1	Setting/Acquisition	-99,999.9999 to 99,999.9999	-99,999.9999	---	Adjust judgement
190		Edge midpoint position X upper limit	Setting/Acquisition	-99,999.9999 to 99,999.9999	99,999.9999	---	Adjust judgement
191		Edge midpoint position X lower limit	Setting/Acquisition	-99,999.9999 to 99,999.9999	-99,999.9999	---	Adjust judgement
192		Edge midpoint position Y upper limit	Setting/Acquisition	-99,999.9999 to 99,999.9999	99,999.9999	---	Adjust judgement
193		Edge midpoint position Y lower limit	Setting/Acquisition	-99,999.9999 to 99,999.9999	-99,999.9999	---	Adjust judgement
194		Position compensation X upper limit	Setting/Acquisition	-99,999.9999 to 99,999.9999	99,999.9999	---	Adjust judgement
195		Position compensation X lower limit	Setting/Acquisition	-99,999.9999 to 99,999.9999	-99,999.9999	---	Adjust judgement
196		Position compensation Y upper limit	Setting/Acquisition	-99,999.9999 to 99,999.9999	99,999.9999	---	Adjust judgement
197	Position compensation Y lower limit	Setting/Acquisition	-99,999.9999 to 99,999.9999	-99,999.9999	---	Adjust judgement	

External reference number	Category	Data name	Setting/Acquisition	Data range	Default	Expression text string	Logged data/Judgement parameter
310	Logging conditions	Data logging switch for entire unit	Setting/Acquisition	0: Data logging OFF, 1: Data logging ON	0	---	---
311		Data logging switch for judgement	Setting/Acquisition	0: Data logging OFF, 1: Data logging ON	0	---	---
312		Data logging switch for scroll X	Setting/Acquisition	0: Data logging OFF, 1: Data logging ON	0	---	---
313		Data logging switch for scroll Y	Setting/Acquisition	0: Data logging OFF, 1: Data logging ON	0	---	---
314		Data logging switch for detected edge position X0	Setting/Acquisition	0: Data logging OFF, 1: Data logging ON	0	---	---
315		Data logging switch for detected edge position Y0	Setting/Acquisition	0: Data logging OFF, 1: Data logging ON	0	---	---
316		Data logging switch for detected edge position X1	Setting/Acquisition	0: Data logging OFF, 1: Data logging ON	0	---	---
317		Data logging switch for detected edge position Y1	Setting/Acquisition	0: Data logging OFF, 1: Data logging ON	0	---	---
318		Data logging switch for detected edge midpoint position X	Setting/Acquisition	0: Data logging OFF, 1: Data logging ON	0	---	---
319		Data logging switch for detected edge midpoint position Y	Setting/Acquisition	0: Data logging OFF, 1: Data logging ON	0	---	---
700	Display settings	Position compensation X display	Setting/Acquisition	0: ON, 1: OFF	0	---	---
701		Position compensation Y display	Setting/Acquisition	0: ON, 1: OFF	0	---	---
702		Detected edge midpoint position X display	Setting/Acquisition	0: ON, 1: OFF	0	---	---
703		Detected edge midpoint position Y display	Setting/Acquisition	0: ON, 1: OFF	0	---	---
704		Detected edge position X0 display	Setting/Acquisition	0: ON, 1: OFF	0	---	---
705		Detected edge position Y0 display	Setting/Acquisition	0: ON, 1: OFF	0	---	---
706		Detected edge position X1 display	Setting/Acquisition	0: ON, 1: OFF	0	---	---
707		Detected edge position Y1 display	Setting/Acquisition	0: ON, 1: OFF	0	---	---

## Edge Rotation Position Compensation

External reference number	Category	Data name	Setting/Acquisition	Data range	Default	Expression text string	Logged data/Judgement parameter	
0	Measurement result	Judgement	Acquisition only	-2: No judgement (not measured), 0: Judgement is OK, -1: Judgement is NG, -13: Teaching not performed error, -14: Figure not registered error, -15: Out of range error	-2	JG	Logged data	
5		Position compensation TH	Acquisition only	-99,999.9999 to 99,999.9999	0	DT	Logged data	
6		Detected edge position X0	Acquisition only	-99,999.9999 to 99,999.9999	0	X0	Logged data	
7		Detected edge position Y0	Acquisition only	-99,999.9999 to 99,999.9999	0	Y0	Logged data	
8		Detected edge position X1	Acquisition only	-99,999.9999 to 99,999.9999	0	X1	Logged data	
9		Detected edge position Y1	Acquisition only	-99,999.9999 to 99,999.9999	0	Y1	Logged data	
10		Detected edge angle	Acquisition only	-180 to 180	0	TH	Logged data	
11		Standard position X0	Acquisition only	-99,999.9999 to 99,999.9999	0	SX0	Logged data	
12		Standard position Y0	Acquisition only	-99,999.9999 to 99,999.9999	0	SY0	Logged data	
13		Standard position X1	Acquisition only	-99,999.9999 to 99,999.9999	0	SX1	Logged data	
14		Standard position Y1	Acquisition only	-99,999.9999 to 99,999.9999	0	SY1	Logged data	
15		Standard edge angle	Acquisition only	-180 to 180	0	STH	Logged data	
103		Output parameter	Reflect	Setting/Acquisition	0: Yes, 1: No	0	---	---
120		Measurement conditions	Position compensation precision	Setting/Acquisition	0: None, 1: Bilinear	0	---	---
121			Setting method	Setting/Acquisition	0: Cancel position compensation, 1: Position compensation based on internal edge position measurement	1	---	---
122	Position compensation image		Setting/Acquisition	0: Camera image, 1: Previous image	0	---	---	

External reference number	Category	Data name	Setting/Acquisition	Data range	Default	Expression text string	Logged data/Judgement parameter
140	Measurement conditions	Edge color specification 0	Setting/Acquisition	0: No edge color specification, 1: Edge color specification	0	---	---
141		Edge color R0	Setting/Acquisition	0 to 255	255	---	---
142		Edge color G0	Setting/Acquisition	0 to 255	255	---	---
143		Edge color B0	Setting/Acquisition	0 to 255	255	---	---
147		Density change 0	Setting/Acquisition	0: Color IN, 1: Color OUT	0	---	---
149		Edge level 0	Setting/Acquisition	0 to 100	50	---	---
150		Noise level 0	Setting/Acquisition	0 to 442	5	---	---
153		Monochrome density change 0	Setting/Acquisition	(Monochrome Cameras) 0: Light to Dark, 1: Dark to Light	0	---	---
157		Measurement method 0	Setting/Acquisition	(Monochrome Cameras) 0: Projection, 1: Differentiation	0	---	---
160		Edge color specification 0	Setting/Acquisition	0: No edge color specification, 1: Edge color specification	0	---	---
161		Edge color R1	Setting/Acquisition	0 to 255	255	---	---
162		Edge color G1	Setting/Acquisition	0 to 255	255	---	---
163		Edge color B1	Setting/Acquisition	0 to 255	255	---	---
167		Density change 1	Setting/Acquisition	0: Color IN, 1: Color OUT	0	---	---
169		Edge level 1	Setting/Acquisition	0 to 100	50	---	---
170		Noise level 1	Setting/Acquisition	0 to 442	5	---	---
173		Monochrome density change 1	Setting/Acquisition	(Monochrome Cameras) 0: Light to Dark, 1: Dark to Light	0	---	---
177		Measurement method 1	Setting/Acquisition	(Monochrome Cameras) 0: Projection, 1: Differentiation	0	---	---

External reference number	Category	Data name	Setting/Acquisition	Data range	Default	Expression text string	Logged data/Judgement parameter	
180	Judgement conditions	Edge position X upper limit 0	Setting/Acquisition	-99,999.9999 to 99,999.9999	99,999.9999	---	Adjust judgement	
181		Edge position X lower limit 0	Setting/Acquisition	-99,999.9999 to 99,999.9999	-99,999.9999	---	Adjust judgement	
182		Edge position Y upper limit 0	Setting/Acquisition	-99,999.9999 to 99,999.9999	99,999.9999	---	Adjust judgement	
183		Edge position Y lower limit 0	Setting/Acquisition	-99,999.9999 to 99,999.9999	-99,999.9999	---	Adjust judgement	
185		Edge position X upper limit 1	Setting/Acquisition	-99,999.9999 to 99,999.9999	99,999.9999	---	Adjust judgement	
186		Edge position X lower limit 1	Setting/Acquisition	-99,999.9999 to 99,999.9999	-99,999.9999	---	Adjust judgement	
187		Edge position Y upper limit 1	Setting/Acquisition	-99,999.9999 to 99,999.9999	99,999.9999	---	Adjust judgement	
188		Edge position Y lower limit 1	Setting/Acquisition	-99,999.9999 to 99,999.9999	-99,999.9999	---	Adjust judgement	
190		Edge angle upper limit	Setting/Acquisition	-180 to 180	180	---	Adjust judgement	
191		Edge angle lower limit	Setting/Acquisition	-180 to 180	-180	---	Adjust judgement	
192		Theta position compensation upper limit	Setting/Acquisition	-360 to 360	360	---	Adjust judgement	
193		Theta position compensation lower limit	Setting/Acquisition	-360 to 360	-360	---	Adjust judgement	
310		Logging conditions	Data logging switch for entire unit	Setting/Acquisition	0: Data logging OFF, 1: Data logging ON	0	---	---
311			Data logging switch for judgement	Setting/Acquisition	0: Data logging OFF, 1: Data logging ON	0	---	---
312	Data logging switch for position compensation TH		Setting/Acquisition	0: Data logging OFF, 1: Data logging ON	0	---	---	
313	Data logging switch for detected edge position X0		Setting/Acquisition	0: Data logging OFF, 1: Data logging ON	0	---	---	
314	Data logging switch for detected edge position Y0		Setting/Acquisition	0: Data logging OFF, 1: Data logging ON	0	---	---	
315	Data logging switch for detected edge position X1		Setting/Acquisition	0: Data logging OFF, 1: Data logging ON	0	---	---	
316	Data logging switch for detected edge position Y1		Setting/Acquisition	0: Data logging OFF, 1: Data logging ON	0	---	---	
317	Data logging switch for detected edge angle		Setting/Acquisition	0: Data logging OFF, 1: Data logging ON	0	---	---	



External reference number	Category	Data name	Setting/Acquisition	Data range	Default	Expression text string	Logged data/Judgement parameter
700	Display settings	Position compensation theta display	Setting/Acquisition	0: ON, 1: OFF	0	---	---
701		Detected edge angle display	Setting/Acquisition	0: ON, 1: OFF	0	---	---
702		Detected edge position X0 display	Setting/Acquisition	0: ON, 1: OFF	0	---	---
703		Detected edge position Y0 display	Setting/Acquisition	0: ON, 1: OFF	0	---	---
704		Detected edge position X1 display	Setting/Acquisition	0: ON, 1: OFF	0	---	---
705		Detected edge position Y1 display	Setting/Acquisition	0: ON, 1: OFF	0	---	---

## Search

External reference number	Category	Data name	Setting/Acquisition	Data range	Default	Expression text string	Logged data/Judgement parameter	
0	Measurement result	Judgement	Acquisition only	-2: No judgement (not measured), 0: Judgement is OK, -1: Judgement is NG, -13: Teaching not performed error, -14: Figure not registered error, -15: Out of range error	-2	JG	Logged data	
5		Correlation	Acquisition only	0 to 100	0	CR[0] to CR[31]	Logged data	
6		Position X	Acquisition only	-99,999.9999 to 99,999.9999	0	X[0] to X[31]	Logged data	
7		Position Y	Acquisition only	-99,999.9999 to 99,999.9999	0	Y[0] to Y[31]	Logged data	
8		Angle	Acquisition only	-180 to 180	0	TH[0] to TH[31]	Logged data	
9		Reference X	Acquisition only	-99,999.9999 to 99,999.9999	0	SX	---	
10		Reference Y	Acquisition only	-99,999.9999 to 99,999.9999	0	SY	---	
11		Reference angle	Acquisition only	-180 to 180	0	ST	---	
12		Detection coordinate X	Acquisition only	-99,999.9999 to 99,999.9999	0	RX	---	
13		Detection coordinate Y	Acquisition only	-99,999.9999 to 99,999.9999	0	RY	---	
14		Count	Acquisition only	0 to 32	0	C	Logged data	
103		Output parameter	Reflect	Setting/Acquisition	0: Yes, 1: No	0	---	---

External reference number	Category	Data name	Setting/Acquisition	Data range	Default	Expression text string	Logged data/Judgement parameter
121	Model region	Rotation	Setting/Acquisition	0: No, 1: Yes	0	---	---
122		Rotation angle upper limit	Setting/Acquisition	-180 to 180	180	---	---
123		Rotation angle lower limit	Setting/Acquisition	-180 to 180	-180	---	---
132	Detection coordinate	Detection point X	Setting/Acquisition	-99,999.9999 to 99,999.9999	0	---	---
133		Detection point Y	Setting/Acquisition	-99,999.9999 to 99,999.9999	0	---	---
134	Measurement condition	Sub-pixel	Setting/Acquisition	0: No, 1: Yes	0	---	---
136	Judgement conditions	Judgement upper limit for search coordinate X	Setting/Acquisition	-99,999.9999 to 99,999.9999	99,999.9999	---	Adjust judgement
137		Judgement lower limit for search coordinate X	Setting/Acquisition	-99,999.9999 to 99,999.9999	-99,999.9999	---	Adjust judgement
138		Judgement upper limit for search coordinate Y	Setting/Acquisition	-99,999.9999 to 99,999.9999	99,999.9999	---	Adjust judgement
139		Judgement lower limit for search coordinate Y	Setting/Acquisition	-99,999.9999 to 99,999.9999	-99,999.9999	---	Adjust judgement
140		Judgement upper limit for search angle	Setting/Acquisition	-180 to 180	180	---	Adjust judgement
141		Judgement lower limit for search angle	Setting/Acquisition	-180 to 180	-180	---	Adjust judgement
142		Judgement upper limit for correlation	Setting/Acquisition	0 to 100	100	---	Adjust judgement
143		Judgement lower limit for correlation	Setting/Acquisition	0 to 100	60	---	Adjust judgement
146	Measurement conditions	Sort condition	Setting/Acquisition	For Multiple Searches 0: Ascending order of correlation value, 1: Descending order of correlation value, 2: Ascending order of position X, 3: Descending order of position X, 4: Ascending order of position Y, 5: Descending order of position Y	1	---	---
148	Judgement conditions	Judgement upper limit for detection count	Setting/Acquisition	0 to 32	32	---	Adjust judgement
149		Judgement lower limit for detection count	Setting/Acquisition	0 to 32	0	---	Adjust judgement

External reference number	Category	Data name	Setting/Acquisition	Data range	Default	Expression text string	Logged data/Judgement parameter
150	Measurement conditions	Multiple output	Setting/Acquisition	0: No, 1: Yes	0	---	---
152		Extraction condition, X upper limit	Setting/Acquisition	-99,999.9999 to 99,999.9999	99,999.9999	---	---
153		Extraction condition, X lower limit	Setting/Acquisition	-99,999.9999 to 99,999.9999	-99,999.9999	---	---
154		Extraction condition, Y upper limit	Setting/Acquisition	-99,999.9999 to 99,999.9999	99,999.9999	---	---
155		Extraction condition, Y lower limit	Setting/Acquisition	-99,999.9999 to 99,999.9999	-99,999.9999	---	---
160		Detection count	Setting/Acquisition	1 to 32	32	---	---
300	Logging conditions	Number of data log records	Setting/Acquisition	1 to 32	32	---	---
310		Data logging switch for entire unit	Setting/Acquisition	0: Data logging OFF, 1: Data logging ON	1	---	---
311		Data logging switch for judgement	Setting/Acquisition	0: Data logging OFF, 1: Data logging ON	1	---	---
312		Data logging switch for correlation	Setting/Acquisition	0: Data logging OFF, 1: Data logging ON	1	---	---
313		Data logging switch for position X	Setting/Acquisition	0: Data logging OFF, 1: Data logging ON	1	---	---
314		Data logging switch for position Y	Setting/Acquisition	0: Data logging OFF, 1: Data logging ON	1	---	---
315		Data logging switch for measurement angle	Setting/Acquisition	0: Data logging OFF, 1: Data logging ON	1	---	---
321		Data logging switch for detection count	Setting/Acquisition	0: Data logging OFF, 1: Data logging ON	1	---	---
700	Display settings	Correlation display	Setting/Acquisition	0: Display, 1: Do not display	0	---	---
701		Position X display	Setting/Acquisition	0: Display, 1: Do not display	0	---	---
702		Position Y display	Setting/Acquisition	0: Display, 1: Do not display	0	---	---
703		Measurement angle display	Setting/Acquisition	0: Display, 1: Do not display	0	---	---
704		Count display	Setting/Acquisition	0: Display, 1: Do not display	0	---	---
800		Position X display pattern	Setting/Acquisition	0: Absolute value, 1: Relative value	0	---	---
801		Position Y display pattern	Setting/Acquisition	0: Absolute value, 1: Relative value	0	---	---
802		Measured angle display pattern	Setting/Acquisition	0: Absolute value, 1: Relative value	0	---	---

## Sensitive Search

External reference number	Category	Data name	Setting/Acquisition	Data range	Default	Expression text string	Logged data/Judgement parameter	
0	Measurement result	Judgement	Acquisition only	-2: No judgement (not measured), 0: Judgement is OK, -1: Judgement is NG, -13: Teaching not performed error, -14: Figure not registered error, -15: Out of range error	-2	JG	Logged data	
5		Correlation	Acquisition only	0 to 100	0	CR	Logged data	
6		Deviation	Acquisition only	Color Camera: 0.000 to 219.9705 Monochrome Camera: 0.000 to 127.000	0	DV	Logged data	
7		Measurement position X (search center position)	Acquisition only	-99,999.9999 to 99,999.9999	0	X	Logged data	
8		Measurement position Y (search center position)	Acquisition only	-99,999.9999 to 99,999.9999	0	Y	Logged data	
9		Angle	Acquisition only	-180 to 180	0	TH	Logged data	
10		Detection X	Acquisition only	-99,999.9999 to 99,999.9999	0	RX	Logged data	
11		Detection Y	Acquisition only	-99,999.9999 to 99,999.9999	0	RY	Logged data	
12		Reference position X	Acquisition only	-99,999.9999 to 99,999.9999	0	SX	Logged data	
13		Reference position Y	Acquisition only	-99,999.9999 to 99,999.9999	0	SY	Logged data	
14		Reference angle	Acquisition only	-180 to 180	0	ST	Logged data	
15		NG sub-region	Acquisition only	0 to 100	0	CT	Logged data	
16		Sub-region number	Acquisition only	0 to 99	0	AN	Logged data	
17		Sub-region number (X)	Acquisition only	0 to 9	0	ANX	Logged data	
18		Sub-region number (Y)	Acquisition only	0 to 9	0	ANY	Logged data	
19		Measurement position X (sub-region)	Acquisition only	-99,999.9999 to 99,999.9999	0	DX	Logged data	
20		Measurement position Y (sub-region)	Acquisition only	-99,999.9999 to 99,999.9999	0	DY	Logged data	
103		Output parameter	Reflect	Setting/Acquisition	0: Yes, 1: No	0	---	---

External reference number	Category	Data name	Setting/Acquisition	Data range	Default	Expression text string	Logged data/Judgement parameter
121	Model region	Rotation	Setting/Acquisition	0: No rotation 1: Rotation	0	---	---
122		Rotation angle upper limit	Setting/Acquisition	-180 to 180	180	---	---
123		Rotation angle lower limit	Setting/Acquisition	-180 to 180	-180	---	---
134	Measurement conditions	Sub-pixel	Setting/Acquisition	0: No, 1: Yes	0	---	---
135		Candidate level	Setting/Acquisition	0 to 100	70	---	---
136	Judgement conditions	Judgement upper limit for search coordinate X	Setting/Acquisition	-99,999.9999 to 99,999.9999	99,999.9999	---	Adjust judgement
137		Judgement lower limit for search coordinate X	Setting/Acquisition	-99,999.9999 to 99,999.9999	-99,999.9999	---	Adjust judgement
138		Judgement upper limit for search coordinate Y	Setting/Acquisition	-99,999.9999 to 99,999.9999	99,999.9999	---	Adjust judgement
139		Judgement lower limit for search coordinate Y	Setting/Acquisition	-99,999.9999 to 99,999.9999	-99,999.9999	---	Adjust judgement
140		Judgement upper limit for search angle	Setting/Acquisition	-180 to 180	180	---	Adjust judgement
141		Judgement lower limit for search angle	Setting/Acquisition	-180 to 180	-180	---	Adjust judgement
142		Judgement upper limit for correlation	Setting/Acquisition	0 to 100	100	---	Adjust judgement
143		Judgement lower limit for correlation	Setting/Acquisition	0 to 100	60	---	Adjust judgement
145		Density deviation upper limit	Setting/Acquisition	Color Cameras: 0 to 221 Monochrome Cameras: 0 to 127	Color Camera: 221 Monochrome Camera: 127	---	Adjust judgement
146		Density deviation lower limit	Setting/Acquisition	Color Cameras: 0 to 221 Monochrome Cameras: 0 to 127	0	---	Adjust judgement
147	NG sub-region upper limit	Setting/Acquisition	0 to 100	100	---	---	
148	NG sub-region lower limit	Setting/Acquisition	0 to 100	0	---	---	
153	Measurement conditions	Plain inspection	Setting/Acquisition	0: No, 1: Yes	0	---	---
169		Gain setting	Setting/Acquisition	0: 3×3 sub-divisions, 1: 5×5 sub-divisions, 2: 9×9 sub-divisions	1	---	---
310	Logging conditions	Data logging switch for entire unit	Setting/Acquisition	0: Data logging OFF, 1: Data logging ON	1	---	---
311		Data logging switch for judgement	Setting/Acquisition	0: Data logging OFF, 1: Data logging ON	1	---	---
312		Data logging switch for correlation	Setting/Acquisition	0: Data logging OFF, 1: Data logging ON	1	---	---
313		Data logging switch for density deviation	Setting/Acquisition	0: Data logging OFF, 1: Data logging ON	1	---	---

External reference number	Category	Data name	Setting/Acquisition	Data range	Default	Expression text string	Logged data/Judgement parameter
314	Logging conditions	Data logging switch for position X	Setting/Acquisition	0: Data logging OFF, 1: Data logging ON	1	---	---
315		Data logging switch for position Y	Setting/Acquisition	0: Data logging OFF, 1: Data logging ON	1	---	---
316		Data logging switch for measurement angle	Setting/Acquisition	0: Data logging OFF, 1: Data logging ON	1	---	---
317		Data logging switch for reference position X	Setting/Acquisition	0: Data logging OFF, 1: Data logging ON	1	---	---
318		Data logging switch for reference position Y	Setting/Acquisition	0: Data logging OFF, 1: Data logging ON	1	---	---
319		Data logging switch for reference angle	Setting/Acquisition	0: Data logging OFF, 1: Data logging ON	1	---	---
320		Data logging switch for NG sub-region	Setting/Acquisition	0: Data logging OFF, 1: Data logging ON	1	---	---
321		Data logging switch for sub-region correlation	Setting/Acquisition	0: Data logging OFF, 1: Data logging ON	1	---	---
322		Data logging switch for sub-region density deviation	Setting/Acquisition	0: Data logging OFF, 1: Data logging ON	1	---	---
323		Data logging switch for sub-region number	Setting/Acquisition	0: Data logging OFF, 1: Data logging ON	1	---	---
324		Data logging switch for sub-region number (X)	Setting/Acquisition	0: Data logging OFF, 1: Data logging ON	1	---	---
325		Data logging switch for sub-region number (Y)	Setting/Acquisition	0: Data logging OFF, 1: Data logging ON	1	---	---
326		Data logging switch for measurement position X (sub-region)	Setting/Acquisition	0: Data logging OFF, 1: Data logging ON	1	---	---
327		Data logging switch for measurement position Y (sub-region)	Setting/Acquisition	0: Data logging OFF, 1: Data logging ON	1	---	---
700	Display settings	Correlation display	Setting/Acquisition	0: Display, 1: Do not display	0	---	---
701		Position X display	Setting/Acquisition	0: Display, 1: Do not display	0	---	---
702		Position Y display	Setting/Acquisition	0: Display, 1: Do not display	0	---	---
703		Measurement angle display	Setting/Acquisition	0: Display, 1: Do not display	0	---	---
704		Density deviation display	Setting/Acquisition	0: Display, 1: Do not display	0	---	---
705		NG sub-region display	Setting/Acquisition	0: Display, 1: Do not display	1	---	---
800	Measurement result display	Position X display pattern	Setting/Acquisition	0: Absolute value, 1: Relative value	0	---	---
801		Position Y display pattern	Setting/Acquisition	0: Absolute value, 1: Relative value	0	---	---
802		Measured angle display pattern	Setting/Acquisition	0: Absolute value, 1: Relative value	0	---	---

External reference number	Category	Data name	Setting/Acquisition	Data range	Default	Expression text string	Logged data/Judgement parameter
1000+N (N=0 to 99)	Measurement result	Sub-region correlation N	Acquisition only	0 to 100	0	CRN	---
1100+N (N=0 to 99)		Sub-region density deviation N	Acquisition only	Sub-region density deviation N	0	DVN	---

## Shape Search II

External reference number	Category	Data name	Setting/Acquisition	Data range	Default	Expression text string	Logged data/Judgement parameter	
0	Measurement result	Judgement	Acquisition only	-2: No judgement (not measured), 0: Judgement is OK, -1: Judgement is NG, -13: Teaching not performed error, -14: Figure not registered error, -15: Out of range error	-2	JG	Logged data	
5		Correlation	Acquisition only	0 to 100	0	CR[0] to CR[31]	Logged data	
6		Position X	Acquisition only	-99,999.9999 to 99,999.9999	0	X[0] to X[31]	Logged data	
7		Position Y	Acquisition only	-99,999.9999 to 99,999.9999	0	Y[0] to Y[31]	Logged data	
8		Angle	Acquisition only	-180 to 180	0	TH[0] to TH[31]	Logged data	
9		Reference X	Acquisition only	-99,999.9999 to 99,999.9999	0	SX	---	
10		Reference Y	Acquisition only	-99,999.9999 to 99,999.9999	0	SY	---	
11		Reference angle	Acquisition only	-180 to 180	0	ST	---	
12		Detection coordinate X	Acquisition only	-99,999.9999 to 99,999.9999	0	RX	---	
13		Detection coordinate Y	Acquisition only	-99,999.9999 to 99,999.9999	0	RY	---	
14		Count	Acquisition only	0 to 32	0	C	Logged data	
103		Output parameter	Reflect	Setting/Acquisition	0: Yes, 1: No	0	---	---
120		Model region	Rotation	Setting/Acquisition	0: No, 1: Yes	0	---	---
121			Rotation angle upper limit	Setting/Acquisition	-180 to 180	180	---	---
122	Rotation angle lower limit		Setting/Acquisition	-180 to 180	-180	---	---	

External reference number	Category	Data name	Setting/Acquisition	Data range	Default	Expression text string	Logged data/Judgement parameter
127	Measurement conditions	Previous conversion mode	Setting/Acquisition	0: Previous conversion mode OFF, 1: Previous conversion mode ON	0	---	---
133		Candidate level	Setting/Acquisition	0 to 100	60	---	---
134	Detection point coordinate	Detection point X	Setting/Acquisition	-99,999.9999 to 99,999.9999	0	---	---
135		Detection point Y	Setting/Acquisition	-99,999.9999 to 99,999.9999	0	---	---
136	Measurement condition	Sort condition	Setting/Acquisition	0: Ascending order of correlation value, 1: Descending order of correlation value, 2: Ascending order of position X, 3: Descending order of position X, 4: Ascending order of position Y, 5: Descending order of position Y	1	---	---
138	Judgement conditions	Judgement upper limit for correlation	Setting/Acquisition	0 to 100	100	---	Adjust judgement
139		Judgement lower limit for correlation	Setting/Acquisition	0 to 100	60	---	Adjust judgement
140		Judgement upper limit for detection count	Setting/Acquisition	0 to 32	32	---	Adjust judgement
141		Judgement lower limit for detection count	Setting/Acquisition	0 to 32	0	---	Adjust judgement
142		Judgement upper limit for search coordinate X	Setting/Acquisition	-99,999.9999 to 99,999.9999	99,999.9999	---	Adjust judgement
143		Judgement lower limit for search coordinate X	Setting/Acquisition	-99,999.9999 to 99,999.9999	-99,999.9999	---	Adjust judgement
144		Judgement upper limit for search coordinate Y	Setting/Acquisition	-99,999.9999 to 99,999.9999	99,999.9999	---	Adjust judgement
145		Judgement lower limit for search coordinate Y	Setting/Acquisition	-99,999.9999 to 99,999.9999	-99,999.9999	---	Adjust judgement
146		Judgement upper limit for search angle	Setting/Acquisition	-180 to 180	180	---	Adjust judgement
147		Judgement lower limit for search angle	Setting/Acquisition	-180 to 180	-180	---	Adjust judgement
152	Measurement conditions	Extraction condition, X upper limit	Setting/Acquisition	-99,999.9999 to 99,999.9999	99,999.9999	---	Adjust judgement
153		Extraction condition, X lower limit	Setting/Acquisition	-99,999.9999 to 99,999.9999	-99,999.9999	---	Adjust judgement
154		Extraction condition, Y upper limit	Setting/Acquisition	-99,999.9999 to 99,999.9999	99,999.9999	---	Adjust judgement
155		Extraction condition, Y lower limit	Setting/Acquisition	-99,999.9999 to 99,999.9999	-99,999.9999	---	Adjust judgement
161		Detection count	Setting/Acquisition	1 to 32	32	---	---
170		Model mode	Setting/Acquisition	0: Fast, 1: Stable	0	---	---



External reference number	Category	Data name	Setting/Acquisition	Data range	Default	Expression text string	Logged data/Judgement parameter
300	Logging conditions	Number of data log records upper limit	Setting/Acquisition	1 to 32	32	---	---
310		Data logging switch for entire unit	Setting/Acquisition	0: Data logging OFF, 1: Data logging ON	1	---	---
311		Data logging switch for judgement	Setting/Acquisition	0: Data logging OFF, 1: Data logging ON	1	---	---
312		Data logging switch for correlation	Setting/Acquisition	0: Data logging OFF, 1: Data logging ON	1	---	---
313		Data logging switch for position X	Setting/Acquisition	0: Data logging OFF, 1: Data logging ON	1	---	---
314		Data logging switch for position Y	Setting/Acquisition	0: Data logging OFF, 1: Data logging ON	1	---	---
315		Data logging switch for measurement angle	Setting/Acquisition	0: Data logging OFF, 1: Data logging ON	1	---	---
321		Data logging switch for detection count	Setting/Acquisition	0: Data logging OFF, 1: Data logging ON	1	---	---
700	Display settings	Correlation display	Setting/Acquisition	0: Display, 1: Do not display	0	---	---
701		Position X display	Setting/Acquisition	0: Display, 1: Do not display	0	---	---
702		Position Y display	Setting/Acquisition	0: Display, 1: Do not display	0	---	---
703		Measurement angle display	Setting/Acquisition	0: Display, 1: Do not display	0	---	---
704		Count display	Setting/Acquisition	0: Display, 1: Do not display	0	---	---
800		Position X display pattern	Setting/Acquisition	0: Absolute value, 1: Relative value	0	---	---
801		Position Y display pattern	Setting/Acquisition	0: Absolute value, 1: Relative value	0	---	---
802		Measurement angle display pattern	Setting/Acquisition	0: Absolute value, 1: Relative value	0	---	---

## Edge Position

External reference number	Category	Data name	Setting/Acquisition	Data range	Default	Expression text string	Logged data/Judgement parameter
0	Measurement result	Judgement	Acquisition only	-2: No judgement (not measured), 0: Judgement is OK, -1: Judgement is NG, -13: Teaching not performed error, -14: Figure not registered error, -15: Out of range error	-2	JG	Logged data
5		Edge position X	Acquisition only	-99,999.9999 to 99,999.9999	0	X	Logged data
6		Edge position Y	Acquisition only	-99,999.9999 to 99,999.9999	0	Y	Logged data
7		Standard position X	Acquisition only	-99,999.9999 to 99,999.9999	0	SX	---
8		Standard position Y	Acquisition only	-99,999.9999 to 99,999.9999	0	SY	---
9		Difference in position	Acquisition only	-99,999.9999 to 99,999.9999	0	DF	Logged data
120	Set color	Set color	Setting/Acquisition	0: No edge color specification, 1: Edge color specification	0	---	---
132	Measurement conditions	Edge level	Setting/Acquisition	0 to 100	50	---	---
133		Noise level	Setting/Acquisition	0 to 442	5	---	---
136	Judgement conditions	Edge position X upper limit	Setting/Acquisition	-99,999.9999 to 99,999.9999	99,999.9999	---	Adjust judgement
137		Edge position X lower limit	Setting/Acquisition	-99,999.9999 to 99,999.9999	-99,999.9999	---	Adjust judgement
138		Edge position Y upper limit	Setting/Acquisition	-99,999.9999 to 99,999.9999	99,999.9999	---	Adjust judgement
139		Edge position Y lower limit	Setting/Acquisition	-99,999.9999 to 99,999.9999	-99,999.9999	---	Adjust judgement
140	Measurement condition	Detection mode for Monochrome Sensor	Setting/Acquisition	0: Light to Dark, 1: Dark to Light	0	---	---
145	Judgement conditions	Edge position offset upper limit	Setting/Acquisition	-99,999.9999 to 99,999.9999	99,999.9999	---	Adjust judgement
146		Edge position offset lower limit	Setting/Acquisition	-99,999.9999 to 99,999.9999	-99,999.9999	---	Adjust judgement

External reference number	Category	Data name	Setting/Acquisition	Data range	Default	Expression text string	Logged data/Judgement parameter
310	Logging conditions	Data logging switch for entire unit	Setting/Acquisition	0: Data logging OFF, 1: Data logging ON	1	---	---
311		Data logging switch for judgement	Setting/Acquisition	0: Data logging OFF, 1: Data logging ON	1	---	---
312		Data logging switch for detected edge position X	Setting/Acquisition	0: Data logging OFF, 1: Data logging ON	1	---	---
313		Data logging switch for detected edge position Y	Setting/Acquisition	0: Data logging OFF, 1: Data logging ON	1	---	---
314		Data logging switch for standard position X	Setting/Acquisition	0: Data logging OFF, 1: Data logging ON	1	---	---
315		Data logging switch for standard position Y	Setting/Acquisition	0: Data logging OFF, 1: Data logging ON	1	---	---
700	Display settings	Edge position offset display	Setting/Acquisition	0: Display, 1: Do not display	1	---	---
701		Detected edge position X display	Setting/Acquisition	0: Display, 1: Do not display	1	---	---
702		Detected edge position Y display	Setting/Acquisition	0: Display, 1: Do not display	1	---	---
800		Detected edge position X display pattern	Setting/Acquisition	0: Display, 1: Do not display	1	---	---
801		Detected edge position Y display pattern	Setting/Acquisition	0: Display, 1: Do not display	1	---	---

## Edge Width

External reference number	Category	Data name	Setting/Acquisition	Data range	Default	Expression text string	Logged data/Judgement parameter
0	Measurement result	Judgement	Acquisition only	-2: No judgement (not measured), 0: Judgement is OK, -1: Judgement is NG, -13: Teaching not performed error, -14: Figure not registered error, -15: Out of range error	-2	JG	---
7		Difference in edge width	Acquisition only	0 to 99,999.9999	0	DF	Logged data
121	Set color	Set color	Setting/Acquisition	Edge color specification 0: Not specified, 1: Specified	0	---	---
131	Measurement conditions	Edge color red	Setting/Acquisition	0 to 255	255	---	---
132		Edge color green	Setting/Acquisition	0 to 255	255	---	---
133		Edge color blue	Setting/Acquisition	0 to 255	255	---	---
137		Edge level	Setting/Acquisition	0 to 100	50	---	---
139		Noise level	Setting/Acquisition	5 to 442	5	---	---

External reference number	Category	Data name	Setting/Acquisition	Data range	Default	Expression text string	Logged data/Judgement parameter
190	Judgement conditions	Edge width upper limit	Setting/Acquisition	-99,999.9999 to 99,999.9999	99,999.9999	---	Adjust judgement
191		Edge width lower limit	Setting/Acquisition	-99,999.9999 to 99,999.9999	0	---	
310	Logging conditions	Data logging switch for entire unit	Setting/Acquisition	0: Data logging OFF, 1: Data logging ON	1	---	---
311		Data logging switch for judgement	Setting/Acquisition	0: Data logging OFF, 1: Data logging ON	1	---	---
312		Data logging switch for edge width	Setting/Acquisition	0: Data logging OFF, 1: Data logging ON	1	---	---
700	Display settings	Edge width display	Setting/Acquisition	0: Display, 1: Do not display	0	---	---
800		Wedge width display pattern	Setting/Acquisition	0: Absolute value, 1: Relative value, 2: Percentage	0	---	---

## Edge Pitch

External reference number	Category	Data name	Setting/Acquisition	Data range	Default	Expression text string	Logged data/Judgement parameter
0	Measurement result	Judgement	Acquisition only	-2: No judgement (not measured), 0: Judgement is OK, -1: Judgement is NG, -13: Teaching not performed error, -14: Figure not registered error, -15: Out of range error	-2	JG	Logged data
5		Edge pitch	Acquisition only	0 to 999	0	N	Logged data
6		Average pitch	Acquisition only	0 to 99,999.9999	0	P	Logged data
7		Maximum pitch	Acquisition only	0 to 99,999.9999	0	PH	Logged data
8		Minimum pitch	Acquisition only	0 to 99,999.9999	0	PL	Logged data
9		Average width	Acquisition only	0 to 99,999.9999	0	W	Logged data
10		Maximum pitch	Acquisition only	0 to 99,999.9999	0	WH	Logged data
11		Minimum pitch	Acquisition only	0 to 99,999.9999	0	WL	Logged data
103	Output parameter	Reflect	Setting/Acquisition	0: Yes, 1: No	0	---	---

External reference number	Category	Data name	Setting/Acquisition	Data range	Default	Expression text string	Logged data/Judgement parameter
120	Measurement conditions	Edge color red	Setting/Acquisition	0 to 255	255	---	---
121		Edge color green	Setting/Acquisition	0 to 255	255	---	---
122		Edge color blue	Setting/Acquisition	0 to 255	255	---	---
127		Edge level	Setting/Acquisition	0 to 100	50	---	---
128		Noise level	Setting/Acquisition	0 to 442	5	---	---
130	Judgement conditions	Edge pitch upper limit	Setting/Acquisition	0 to 1,000	1,000	---	Adjust judgement
131		Edge pitch lower limit	Setting/Acquisition	0 to 1,000	0	---	Adjust judgement
132		Average pitch upper limit	Setting/Acquisition	0 to 99,999.9999	99,999.9999	---	Adjust judgement
133		Average pitch lower limit	Setting/Acquisition	0 to 99,999.9999	0	---	Adjust judgement
134		Pitch upper limit	Setting/Acquisition	0 to 99,999.9999	99,999.9999	---	Adjust judgement
135		Pitch lower limit	Setting/Acquisition	0 to 99,999.9999	0	---	Adjust judgement
136		Average width upper limit	Setting/Acquisition	0 to 99,999.9999	99,999.9999	---	Adjust judgement
137		Average width lower limit	Setting/Acquisition	0 to 99,999.9999	0	---	Adjust judgement
138		Width upper limit	Setting/Acquisition	0 to 99,999.9999	99,999.9999	---	Adjust judgement
139		Width lower limit	Setting/Acquisition	0 to 99,999.9999	0	---	Adjust judgement
140	Measurement conditions	Edge enhancement level	Setting/Acquisition	0 to 442	100	---	---
141		Color to count	Setting/Acquisition	(Monochrome Cameras) 0: White, 1: Black	0	---	---
142		Mode	Setting/Acquisition	(Monochrome Cameras) 0: Standard, 1: Precise	0	---	---

External reference number	Category	Data name	Setting/Acquisition	Data range	Default	Expression text string	Logged data/Judgement parameter
310	Logging conditions	Data logging switch for entire unit	Setting/Acquisition	0: Data logging OFF, 1: Data logging ON	1	---	---
311		Data logging switch for judgement	Setting/Acquisition	0: Data logging OFF, 1: Data logging ON	1	---	---
312		Data logging switch for edge pitch	Setting/Acquisition	0: Data logging OFF, 1: Data logging ON	1	---	---
313		Data logging switch for average pitch	Setting/Acquisition	0: Data logging OFF, 1: Data logging ON	1	---	---
314		Data logging switch for maximum pitch	Setting/Acquisition	0: Data logging OFF, 1: Data logging ON	1	---	---
315		Data logging switch for minimum pitch	Setting/Acquisition	0: Data logging OFF, 1: Data logging ON	1	---	---
316		Data logging switch for average width	Setting/Acquisition	0: Data logging OFF, 1: Data logging ON	1	---	---
317		Data logging switch for maximum width	Setting/Acquisition	0: Data logging OFF, 1: Data logging ON	1	---	---
318		Data logging switch for minimum width	Setting/Acquisition	0: Data logging OFF, 1: Data logging ON	1	---	---
700	Display settings	Edge pitch display	Setting/Acquisition	0: Display, 1: Do not display	0	---	---
701		Average pitch display	Setting/Acquisition	0: Display, 1: Do not display	0	---	---
702		Pitch display	Setting/Acquisition	0: Display, 1: Do not display	0	---	---
703		Average width display	Setting/Acquisition	0: Display, 1: Do not display	0	---	---
704		Width display	Setting/Acquisition	0: Display, 1: Do not display	0	---	---

## Area

External reference number	Category	Data name	Setting/Acquisition	Data range	Default	Expression text string	Logged data/Judgement parameter
0	Measurement result	Judgement	Acquisition only	-2: No judgement (not measured), 0: Judgement is OK, -1: Judgement is NG, -13: Teaching not performed error, -14: Figure not registered error, -15: Out of range error	-2	JG	---
5		Area	Acquisition only	0 to 999,999,999.9999	0	AR	---
11		Area deviation	Acquisition only	-999,999,999.9999 to 999,999,999.9999	0	DF	Logged data

External reference number	Category	Data name	Setting/Acquisition	Data range	Default	Expression text string	Logged data/Judgement parameter
127	Measurement conditions	Background color	Setting/Acquisition	0: Black, 1: White, 2: Red, 3: Green, or 4: Blue	0	---	---
128		Fill profile	Setting/Acquisition	0: No, 1: Fill outline, 2: Filling up holes	0	---	---
129		Area color inversion	Setting/Acquisition	0: None or 1: Enabled The binary inversion is displayed for a Monochrome Camera.	0	---	---
135	Judgement	Judgement upper limit for area	Setting/Acquisition	0 to 999,999,999.9999	999,999,999.9999	---	---
136		Judgement lower limit for area	Setting/Acquisition	0 to 999,999,999.9999	0	---	---
137		Judgement upper limit for gravity X	Setting/Acquisition	-99,999.9999 to 99,999.9999	99,999.9999	---	---
138		Judgement lower limit for gravity X	Setting/Acquisition	-99,999.9999 to 99,999.9999	-99,999.9999	---	---
139		Judgement upper limit for gravity Y	Setting/Acquisition	-99,999.9999 to 99,999.9999	99,999.9999	---	---
140		Judgement lower limit for gravity Y	Setting/Acquisition	-99,999.9999 to 99,999.9999	-99,999.9999	---	---
141		Judgement upper limit for binary threshold	Setting/Acquisition	0 to 255	255	---	---
142		Judgement lower limit for binary threshold	Setting/Acquisition	0 to 255	0	---	---
143	Measurement conditions	Binary image display	Setting/Acquisition	(Monochrome Cameras) 0: No binary image display, 1: Binary image display	1	---	---
144		Image type	Setting/Acquisition	0: Measurement image, 1: Color extraction image, 2: Selected color image, 3: Binary image after extraction	1	---	---
145		Enable/disable multiple selection	Setting/Acquisition	0: Enabled, 1: Disabled	1	---	---
160+N×10 (N=0 to 3)	Set color	Registered color usage flag N	Setting/Acquisition	0: Not used, 1: Used	1(N=0), 0(N=1 to 3)	---	---
161+N×10 (N=0 to 3)	Set color	Registered color OR/NOT flag N	Setting/Acquisition	0: OR, 1: NOT	0	---	---
162+N×10 (N=0 to 3)		Registered color maximum hue N	Setting/Acquisition	0 to 359	359	---	---
163+N×10 (N=0 to 3)		Registered color minimum hue N	Setting/Acquisition	0 to 359	0	---	---
164+N×10 (N=0 to 3)		Registered color maximum saturation N	Setting/Acquisition	0 to 255	255	---	---
165+N×10 (N=0 to 3)		Registered color minimum saturation N	Setting/Acquisition	0 to 255	0	---	---
166+N×10 (N=0 to 3)		Registered color maximum brightness N	Setting/Acquisition	0 to 255	255	---	---
167+N×10 (N=0 to 3)		Registered color minimum brightness N	Setting/Acquisition	0 to 255	0	---	---

External reference number	Category	Data name	Setting/Acquisition	Data range	Default	Expression text string	Logged data/Judgement parameter
310	Logging conditions	Data logging switch for entire unit	Setting/Acquisition	0: Data logging OFF, 1: Data logging ON	1	---	---
311		Data logging switch for judgement	Setting/Acquisition	0: Data logging OFF, 1: Data logging ON	1	---	---
312		Data logging switch for area	Setting/Acquisition	0: Data logging OFF, 1: Data logging ON	1	---	---
700	Display settings	Area display	Setting/Acquisition	0: Display area, 1: Do not display area	0	---	---
701		Gravity X display	Setting/Acquisition	0: Display gravity X, 1: Do not display gravity X	0	---	---
702		Gravity Y display	Setting/Acquisition	0: Display gravity Y, 1: Do not display gravity Y	0	---	---
800		Area display pattern	Setting/Acquisition	0: Absolute value, 1: Relative value, 2: Percentage	0	---	---
801		Gravity X display pattern	Setting/Acquisition	0: Absolute value, 1: Relative value	0	---	---
802		Gravity Y display pattern	Setting/Acquisition	0: Absolute value, 1: Relative value	0	---	---

## Color Data

External reference number	Category	Data name	Setting/Acquisition	Data range	Default	Expression text string	Logged data/Judgement parameter
0	Measurement result	Judgement	Acquisition only	-2: No judgement (not measured), 0: Judgement is OK, -1: Judgement is NG, -13: Teaching not performed error, -14: Figure not registered error, -15: Out of range error	-2	JG	---
5		R average	Acquisition only	0 to 255	0	AR	---
6		G average	Acquisition only	0 to 255	0	AG	---
7		B average	Acquisition only	0 to 255	0	AB	---
8		Color difference	Acquisition only	0 to 442 The density average is displayed for a Monochrome Camera.	0	AD	Logged data
9		Color deviation	Acquisition only	0 to 221 The standard deviation of the density is displayed for a Monochrome Camera.	0	DV	---
103	Output parameter	Reflect	Setting/Acquisition	0: Yes, 1: No		---	---
124	Judgement conditions	Color difference upper limit	Setting/Acquisition	0 to 442	442	---	Adjust judgement
125		Color difference lower limit	Setting/Acquisition	0 to 442	0		



External reference number	Category	Data name	Setting/Acquisition	Data range	Default	Expression text string	Logged data/Judgement parameter
126	Measurement conditions	Color deviation upper limit	Setting/Acquisition	0 to 221	221	---	---
127		Color deviation lower limit	Setting/Acquisition	0 to 221	0	---	---
130		Density average upper limit	Setting/Acquisition	0 to 255	255	---	---
131		Density average lower limit	Setting/Acquisition	0 to 255	0	---	---
132		Density deviation upper limit	Setting/Acquisition	0 to 127	127	---	---
133		Density deviation lower limit	Setting/Acquisition	0 to 127	0	---	---
134		R average upper limit	Setting/Acquisition	0 to 255	255	---	---
135		R average lower limit	Setting/Acquisition	0 to 255	0	---	---
136		G average upper limit	Setting/Acquisition	0 to 255	255	---	---
137		G average lower limit	Setting/Acquisition	0 to 255	0	---	---
138		B average upper limit	Setting/Acquisition	0 to 255	255	---	---
139		B average lower limit	Setting/Acquisition	0 to 255	0	---	---
310		Logging conditions	Entire Unit logging switch	Setting/Acquisition	0: Data logging OFF, 1: Data logging ON	1	---
311	Judgement logging switch		Setting/Acquisition	0: Data logging OFF, 1: Data logging ON	1	---	---
312	Average deviation/density average logging switch		Setting/Acquisition	0: Data logging OFF, 1: Data logging ON	1	---	---
313	Color deviation/density deviation logging switch		Setting/Acquisition	0: Data logging OFF, 1: Data logging ON	1	---	---
314	R average logging switch		Setting/Acquisition	0: Data logging OFF, 1: Data logging ON	1	---	---
315	G average logging switch		Setting/Acquisition	0: Data logging OFF, 1: Data logging ON	1	---	---
316	B average logging switch		Setting/Acquisition	0: Data logging OFF, 1: Data logging ON	1	---	---
318	Standard deviation logging switch		Setting/Acquisition	0: Data logging OFF, 1: Data logging ON	1	---	---
319	Density average difference logging switch		Setting/Acquisition	0: Data logging OFF, 1: Data logging ON	1	---	---
320	Density deviation difference logging switch		Setting/Acquisition	0: Data logging OFF, 1: Data logging ON	1	---	---

External reference number	Category	Data name	Setting/Acquisition	Data range	Default	Expression text string	Logged data/Judgement parameter
700	Display settings	Average color display	Setting/Acquisition	0: Display, 1: Do not display	0	---	---
701		Color deviation display	Setting/Acquisition	0: Display, 1: Do not display	0	---	---
702		R average display	Setting/Acquisition	0: Display, 1: Do not display	0	---	---
703		G average display	Setting/Acquisition	0: Display, 1: Do not display	0	---	---
704		B average display	Setting/Acquisition	0: Display, 1: Do not display	0	---	---
705		Density average display	Setting/Acquisition	0: Display, 1: Do not display	0	---	---
706		Density deviation display	Setting/Acquisition	0: Display, 1: Do not display	0	---	---

## Labeling

External reference number	Category	Data name	Setting/Acquisition	Data range	Default	Expression text string	Logged data/Judgement parameter
0	Measurement result	Judgement	Acquisition only	-2: No judgement (not measured), 0: Judgement is OK, -1: Judgement is NG, -13: Teaching not performed error, -14: Figure not registered error, -15: Out of range error	-2	JG	Logged data
5		Number of labels	Acquisition only	0 to 100	0	L	Logged data
6		Area	Acquisition only	0 to 999,999,999.9999	0	AR[0] to AR[99]	Logged data
7		Gravity center X	Acquisition only	-99,999.9999 to 99,999.9999	0	X[0] to X[99]	Logged data
8		Gravity center Y	Acquisition only	-99,999.9999 to 99,999.9999	0	Y[0] to Y[99]	Logged data
9		Reference area	Acquisition only	0 to 999,999,999.9999	0	SA	---
10		Reference position X	Acquisition only	-99,999.9999 to 99,999.9999	0	SX	---
11		Reference position Y	Acquisition only	-99,999.9999 to 99,999.9999	0	SY	---
15		Total label area	Acquisition only	0 to 999,999,999.9999	0	TAR	Logged data
55		Master angle	Acquisition only	-180 to 180	0	ATH[0] to ATH[99]	Logged data
103	Output parameter	Reflect	Setting/Acquisition	0: Yes, 1: No	0	---	---
127	Extracted image display condition	Background color	Setting/Acquisition	0: Black, 1: White, 2: Red, 3: Green, or 4: Blue	0	---	---

External reference number	Category	Data name	Setting/Acquisition	Data range	Default	Expression text string	Logged data/Judgement parameter
131	Set color	Area color inversion	Setting/Acquisition	0: None or 1: Enabled The binary value is displayed for a Monochrome Camera.	0	---	---
	Binary						
132	Measurement conditions	Filling up holes	Setting/Acquisition	0: No, 1: Yes	0	---	---
133		Outside trimming	Setting/Acquisition	0: No, 1: Yes	0	---	---
136		Label sort condition	Setting/Acquisition	0: Ascending order of area, 1: Descending order of area, 2: Ascending order of gravity X, 3: Descending order of gravity X, 4: Ascending order of gravity Y, 5: Descending order of gravity Y	1	---	---
146	Binary level	Binary level upper limit	Setting/Acquisition	0 to 255	255	---	---
147		Binary level lower limit	Setting/Acquisition	0 to 255	128	---	---
148	Extracted image display condition	Binary image display	Setting/Acquisition	0: No binary image display, 1: Binary image display	1	---	---
149		Image type	Setting/Acquisition	0: Measurement image, 1: Color extraction image, 2: Selected color image 3: Binary image after extraction	1	---	---
152	Measurement conditions	External reference label number	Setting/Acquisition	0 to 100	0	---	---
156		Extraction condition, detection count	Setting/Acquisition	0 to 100	100	---	---
160+N×10 (N=0 to 3)	Set color	Registered color usage flag N	Setting/Acquisition	0: Not used, 1: Used	1	---	---
161+N×10 (N=0 to 3)		Registered color exclusion flag N	Setting/Acquisition	0: OR, 1: NOT	0	---	---
162+N×10 (N=0 to 3)		Registered color maximum hue N	Setting/Acquisition	0 to 359	359	---	---
163+N×10 (N=0 to 3)		Registered color minimum hue N	Setting/Acquisition	0 to 359	0	---	---
164+N×10 (N=0 to 3)		Registered color maximum saturation N	Setting/Acquisition	0 to 255	255	---	---
165+N×10 (N=0 to 3)		Registered color minimum saturation N	Setting/Acquisition	0 to 255	0	---	---
166+N×10 (N=0 to 3)		Registered color maximum brightness N	Setting/Acquisition	0 to 255	255	---	---
167+N×10 (N=0 to 3)		Registered color minimum brightness N	Setting/Acquisition	0 to 255	0	---	---

External reference number	Category	Data name	Setting/Acquisition	Data range	Default	Expression text string	Logged data/Judgement parameter
300	Logging conditions	Number of data log records	Setting/Acquisition	1 to 100	100	---	---
310		Data logging switch for entire unit	Setting/Acquisition	0: Data logging OFF, 1: Data logging ON	1	---	---
311		Data logging switch for judgement	Setting/Acquisition	0: Data logging OFF, 1: Data logging ON	1	---	---
312		Data logging switch for number of labels	Setting/Acquisition	0: Data logging OFF, 1: Data logging ON	1	---	---
313		Data logging switch for area	Setting/Acquisition	0: Data logging OFF, 1: Data logging ON	1	---	---
314		Data logging switch for gravity X	Setting/Acquisition	0: Data logging OFF, 1: Data logging ON	1	---	---
315		Data logging switch for gravity Y	Setting/Acquisition	0: Data logging OFF, 1: Data logging ON	1	---	---
319		Data logging switch for total label area	Setting/Acquisition	0: Data logging OFF, 1: Data logging ON	1	---	---
326		Data logging switch for master angle	Setting/Acquisition	0: Data logging OFF, 1: Data logging ON	1	---	---
602		Judgement	Judgement upper limit for number of labels	Setting/Acquisition	1 to 100	100	---
603	Judgement lower limit for number of labels		Setting/Acquisition	1 to 100	0	---	---
612	Judgement upper limit for label area		Setting/Acquisition	0 to 999,999,999.9999	999,999,999.9999	---	---
613	Judgement lower limit for label area		Setting/Acquisition	0 to 999,999,999.9999	0	---	---
622	Judgement upper limit for area		Setting/Acquisition	0 to 999,999,999.9999	999,999,999.9999	---	---
623	Judgement lower limit for area		Setting/Acquisition	0 to 999,999,999.9999	0	---	---
632	Judgement upper limit for gravity X		Setting/Acquisition	-99,999.9999 to 99,999.9999	99,999.9999	---	---
633	Judgement lower limit for gravity X		Setting/Acquisition	-99,999.9999 to 99,999.9999	-99,999.9999	---	---
642	Judgement upper limit for gravity Y		Setting/Acquisition	-99,999.9999 to 99,999.9999	99,999.9999	---	---
643	Judgement lower limit for gravity Y		Setting/Acquisition	-99,999.9999 to 99,999.9999	-99,999.9999	---	---
652	Judgement upper limit for master angle		Setting/Acquisition	-180 to 180	180	---	---
653	Judgement lower limit for master angle		Setting/Acquisition	-180 to 180	-180	---	---

External reference number	Category	Data name	Setting/Acquisition	Data range	Default	Expression text string	Logged data/Judgement parameter
700	Display settings	Number of labels display	Setting/Acquisition	0: ON, 1: OFF	0	---	---
701		Total label area display	Setting/Acquisition	0: ON, 1: OFF	0	---	---
702		Area display	Setting/Acquisition	0: ON, 1: OFF	0	---	---
703		Gravity X display	Setting/Acquisition	0: ON, 1: OFF	0	---	---
704		Gravity Y display	Setting/Acquisition	0: ON, 1: OFF	0	---	---
705		Master angle display	Setting/Acquisition	0: ON, 1: OFF	0	---	---

# 12-3 Specifications and Dimensions

## Sensor

### Specifications

Item		Single-function models	Standard models	High-resolution models				
Model	NPN	FQ2-S10□□□□	FQ2-S20□□□□	FQ2-S30□□□□-08	FQ2-S30□□□□-08M	FQ2-S30-13	FQ2-S30-13M	
	PNP	FQ2-S15□□□□	FQ2-S25□□□□	FQ2-S35□□□□-08	FQ2-S35□□□□-08M	FQ2-S35-13	FQ2-S35-13M	
Field of view		Refer to Table 1.					Lens is select according to the field of vision and installation distance. Refer to the Optical Chart page.	
Installation distance		Refer to Table 1.						
Main functions	Inspection items	Search, shape search II, sensitive search, area, color data, edge position, edge pitch, edge width, and labeling						
	Number of simultaneous measurements	1	32					
	Position compensation	Supported (360° Model position compensation, Edge position compensation)						
	Number of registered scenes	8	32					
	Calibration	Supported						
Image input	Image processing method	Real color			Monochrome	Real color	Monochrome	
	Image filter	High dynamic range (HDR), image adjustment, polarizing filter (attachment), and white balance (Sensors with Color Cameras only)						
	Image elements	1/3-inch color CMOS		1/2-inch color CMOS	1/2-inch Monochrome CMOS	1/2-inch color CMOS	1/2-inch Monochrome CMOS	
	Shutter	Built-in lighting lit: 1/250 to 1/50,000 Built-in lighting not lit: 1/1 to 1/50,000		Built-in lighting lit: 1/250 to 1/60,000 Built-in lighting not lit: 1/1 to 1/60,000		1/1 to 1/60,000		
	Processing resolution	752×480		928×828		1280×1024		
	Partial input function	Supported horizontally only.		Supported horizontally and vertically				
	Lens mounts	---				C-mounts		
Lighting	Lighting method	Pulse				---		
	Lighting color	White				---		
Data logging	Measurement data	In Sensor: 1,000 items (If a Touch Finder is used, results can be saved up to the capacity of an SD card.)						
	Images	In Sensor: 20 images (If a Touch Finder is used, images can be saved up to the capacity of an SD card.)						
Auxiliary function		Math (arithmetic, calculation functions, trigonometric functions, and logic functions)						
Measurement trigger		External trigger (single or continuous) Communications trigger (Ethernet TCP no-protocol, Ethernet FINS/TCP no-protocol, EtherNet/IP, or PLC Link)						

Item		Single-function models	Standard models	High-resolution models				
Model	NPN	FQ2-S10□□□□	FQ2-S20□□□□	FQ2-S30□□□□-08	FQ2-S30□□□□-08M	FQ2-S30-13	FQ2-S30-13M	
	PNP	FQ2-S15□□□□	FQ2-S25□□□□	FQ2-S35□□□□-08	FQ2-S35□□□□-08M	FQ2-S35-13	FQ2-S35-13M	
I/O specifications	Input signals	7 signals <ul style="list-style-type: none"> <li>• Single measurement input (TRIG)</li> <li>• Control command input (IN0 to IN5)</li> </ul>						
	Output signals	3 signals <ul style="list-style-type: none"> <li>• Control output (BUSY)</li> <li>• Overall judgement output (OR)</li> <li>• Error output (ERROR)</li> </ul> Note: The assignments of the three output signals (OUT0 to OUT2) can be changed to the individual judgements of the inspection items, the image input ready output (READY), or the external lighting timing output (STGOUT).						
	Ethernet specifications	100Base-TX/10Base-T						
	Communications	Ethernet TCP no-protocol, Ethernet FINS/TCP no-protocol, EtherNet/IP, or PLC Link						
	I/O expansion	---	---	Possible by connecting FQ-SDU1□ Sensor Data Unit. 11 inputs and 24 outputs				
	RS-232C	---	---	Possible by connecting FQ-SDU2□ Sensor Data Unit.				
	Input specifications	Refer to Table 2.						
	Output specifications							
Connection method	Special connector cables Power supply and I/O: 1 cable (FQ-WD□□□□) Touch Finder and computer: 1 cable (FQ-WN□□□□)			Special connector cables Power supply I/O and Sensor data units: 1 cable (FQ-WD□□□□ and FQ-WU□□□□) Touch Finder and computer: 1 cable (FQ-WN□□□□)				
Indications	BUSY indicator (BUSY, green), Judgement result indicator (OR, orange), error indicator (ERROR, red), Ethernet communications indicator (ETN, orange) Note: The assignment of the BUSY indicator can be changed to a RUN indicator (display color: green).							
Ratings	Power supply voltage	21.6 to 26.4 VDC (including ripple)						
	Insulation resistance	Between all lead wires and case: 0.5 MΩ (at 250 V)						
	Current consumption	2.4 A max.				0.3 A max.		
Environmental immunity	Ambient temperature range	Operating: 0 to 50°C Storage: -25 to 65°C (with no icing or condensation)			Operating: 0 to 40°C, Storage: -25 to 65°C (with no icing or condensation)			
	Ambient humidity range	Operating and storage: 35% to 85% (with no condensation)						
	Ambient atmosphere	No corrosive gas						
	Vibration resistance (destruction)	10 to 150 Hz, single amplitude: 0.35 mm, X/Y/Z directions 8 min each, 10 times						
	Shock resistance (destruction)	150 m/s <sup>2</sup> 3 times each in 6 direction (up, down, right, left, forward, and backward)						
	Degree of protection	IEC 60529 IP67 (Except when Polarizing Filter Attachment is mounted or connector cap is removed.)				IEC 60529 IP40		

Item		Single-function models	Standard models	High-resolution models			
Model	NPN	FQ2-S10□□□□	FQ2-S20□□□□	FQ2-S30□□□□-08	FQ2-S30□□□□-08M	FQ2-S30-13	FQ2-S30-13M
	PNP	FQ2-S15□□□□	FQ2-S25□□□□	FQ2-S35□□□□-08	FQ2-S35□□□□-08M	FQ2-S35-13	FQ2-S35-13M
Materials		Sensor: PBT, PC, SUS Mounting Bracket: PBT Polarizing Filter Attachment: PBT, PC Ethernet connector: Oil-resistance vinyl compound I/O connector: Lead-free heat-resistant PVC				Cover: Zinc-plated steel, Thickness: 0.6 mm Case: Aluminum diecast alloy (ADC-12) Mounting base: Polycarbonate ABS	
Weight		Depends on field of view and installation distance. Refer to Table 1.				Approx. 160 g without base, Approx. 185 g with base	
Accessories		Mounting Bracket (FQ-XL) (1) Polarizing Filter Attachment (FQ-XF1) (1) Instruction Manual Quick Startup Guide Member Registration Sheet Warning Label				Mounting Base (FQ-XLC) (1) Four Mounting Screws (FQ-XLC) (M3×8 mm)(4) Instruction Manual Quick Startup Guide Member Registration Sheet	
LED class <sup>*2</sup>		Class 2				---	
Applicable standards		EN standard EN 61326 and EC Directive No.2004/104/EC				EN 61326-1:2006 and IEC 61010-1	

Table 1

Single-function models		Standard models		Field of view (H×V) *1	Installation distance	Number of LEDs	Weight
NPN	PNP	NPN	PNP				
FQ2-S10010F	FQ2-S15010F	FQ2-S20010F	FQ2-S25010F	7.5 × 4.7 to 13 × 8.2 mm	38 to 57 mm	4	Approx. 160 g
FQ2-S10050F	FQ2-S15050F	FQ2-S20050F	FQ2-S25050F	13 × 8.2 to 53 × 33 mm	56 to 215 mm	4	
FQ2-S10100F	FQ2-S15100F	FQ2-S20100F	FQ2-S25100F	53 × 33 to 240 × 153 mm	220 to 970 mm	8	Approx. 150 g
FQ2-S10100N	FQ2-S15100N	FQ2-S20100N	FQ2-S25100N	29 × 18 to 300 × 191 mm	32 to 380 mm	8	

High-resolution models		Field of view (H×V) *1	Installation distance	Number of LEDs	Weight
NPN	PNP				
FQ2-S30010F-□□□	FQ2-S35010F-□□□	7.5×6.7 to 13×11.6 mm	38 to 57 mm	4	Approx. 160 g
FQ2-S30050F-□□□	FQ2-S35050F-□□□	13×11.6 to 53×47.3 mm	56 to 215 mm	4	
FQ2-S30100F-□□□	FQ2-S35100F-□□□	53×47.3 to 240×214 mm	220 to 970 mm	8	Approx. 150 g
FQ2-S30100N-□□□	FQ2-S35100N-□□□	29×25.9 to 300×268 mm	32 to 380 mm	8	

\*1: Tolerance: ±10% max.

\*2: Applicable standards: IEC 60825-1:1993 +A1:1997 +A2:2001, EN 60825-1:1994 +A1:2002 +A2:2001, and JIS C 6802:2005

Table 2

Item	NPN	PNP
Input specifications	ON: Shorted to 0 V, or 1.5 V max. OFF: Open (leakage current: 0.1 mA max.)	ON: Shorted to power supply voltage, or power supply voltage -1.5 V max. OFF: Open (leakage current: 0.1 mA max.)
Output specifications <sup>*3</sup>	NPN open collector 30 VDC, 50 mA max., residual voltage: 2.0 V max.	PNP open collector 30 VDC, 50 mA max., residual voltage: 2.0 V max.

\*3: Do not allow the load current to exceed 50 mA. The output circuit may be damaged if the load current exceeds 50 mA.



## Dimensions

FQ2-S10010F/-S10050F

FQ2-S20010F/-S20050F

(Unit: mm)

FQ2-S15010F/-S15050F

FQ2-S25010F/-S25050F

FQ2-S30010F-08/-S35010F-08/-S30010F-08M/-S35010F-08M

FQ2-S30050F-08/-S35050F-08/-S30050F-08M/-S35050F-08M

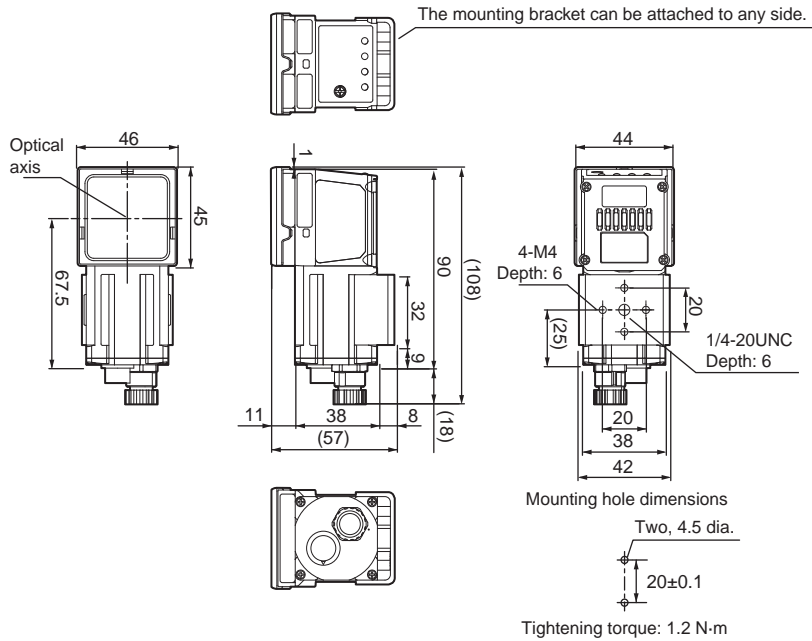

FQ2-S10100F/-S10100N/-S20100N

FQ2-S20100F

(Unit: mm)

FQ2-S15100F/-S15100N/-S25100N

FQ2-S25100F

FQ2-S30100F-08/-S35100F-08/-S30100F-08M/-S35100F-08M

FQ2-S30100N-08/-S35100N-08/-S30100N-08M/-S35100N-08M

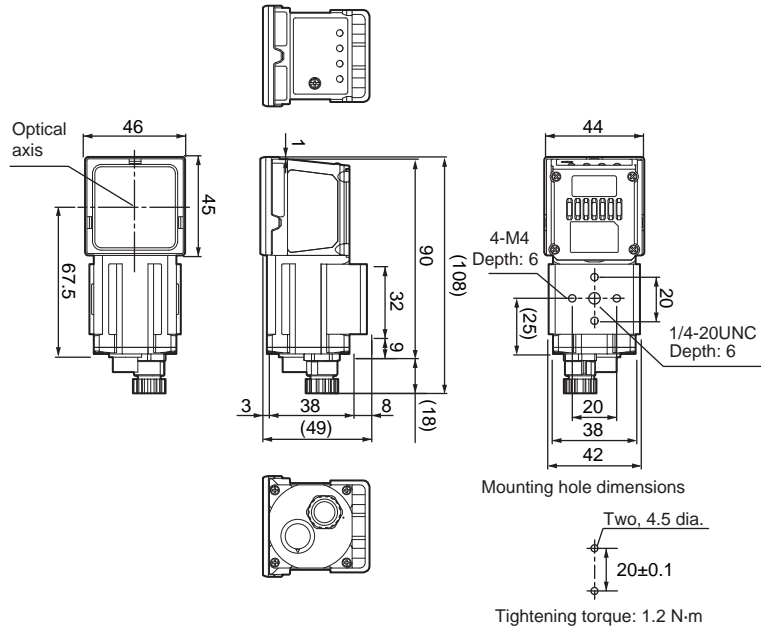

See the diagram below when mounting bracket FQ-XL2 is attached.

(Unit: mm)

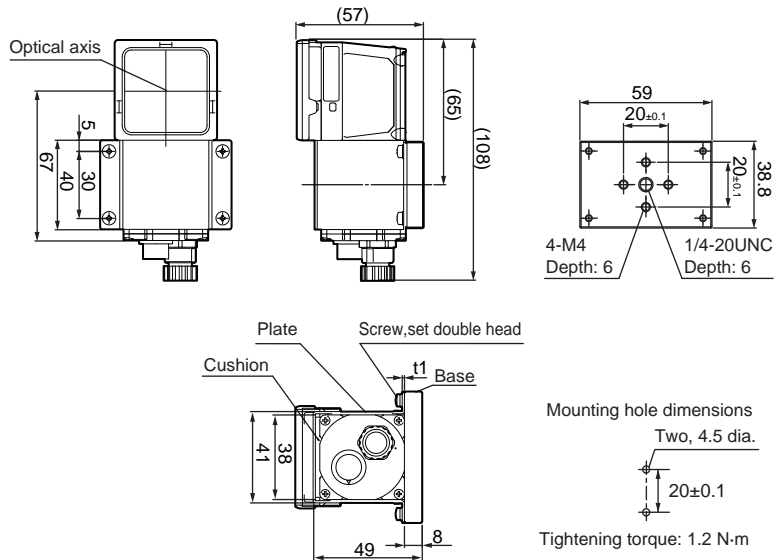

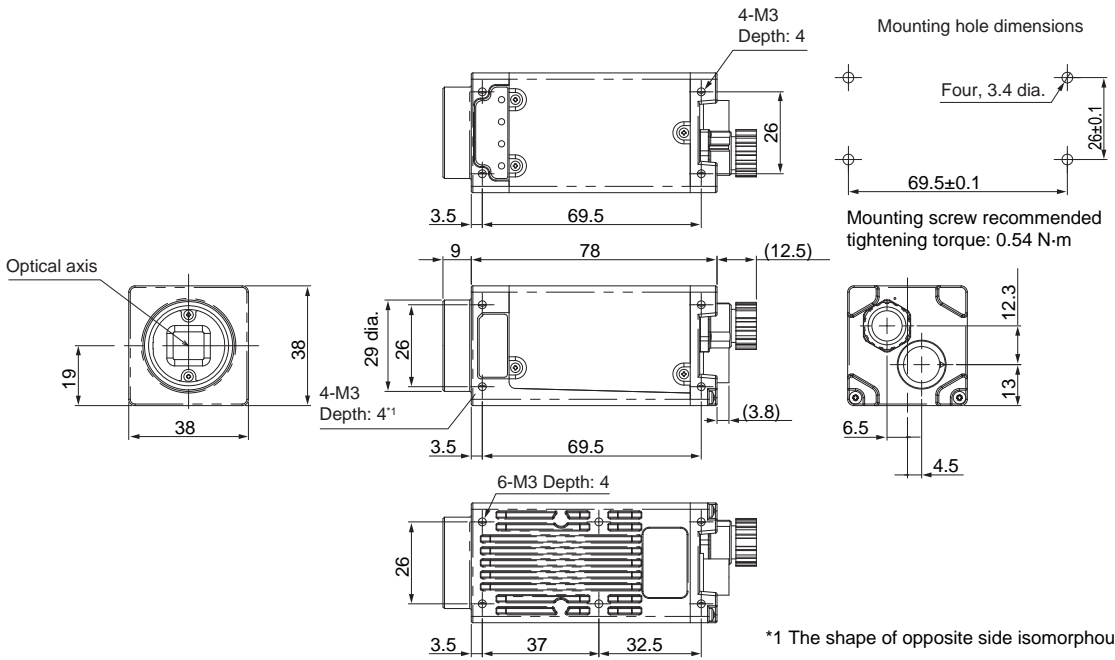

Mounting Base

(Unit: mm)

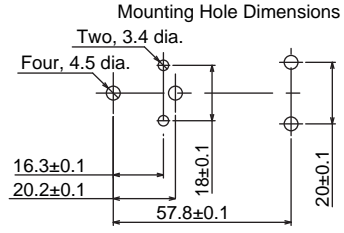
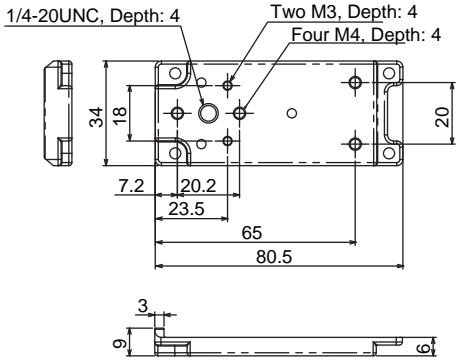

Mounting screw recommended tightening torque: 0.54 N·m

# Touch Finder

## Specifications

Item		Model with DC power supply		Model with AC/DC/battery power supply	
		FQ2-D30		FQ2-D31	
Number of connectable Sensors		Number of sensors that can be recognized (switched): 32, number of sensor that can displayed on monitor: 8			
Main functions	Types of measurement displays	Last result display, last NG display, trend monitor, histograms			
	Types of display images	Through, frozen, zoom-in, and zoom-out images			
	Data logging	Measurement results, measured images			
	Menu language	English, German, French, Italian, Spanish, Traditional Chinese, Simplified Chinese, Korean, or Japanese			
Indications	LCD	Display device	3.5-inch TFT color LCD		
		Pixels	320 × 240		
		Display colors	16,777,216		
	Backlight	Life expectancy <sup>1</sup>	50,000 hours at 25°C		
		Brightness adjustment	Provided		
		Screen saver	Provided (The time setting can be changed.)		
	Indicators	Power indicator (color: green): POWER Error indicator (color: red): ERROR SD card access indicator (color: yellow): SD ACCESS		Power indicator (color: green): POWER Error indicator (color: red): ERROR SD card access indicator (color: yellow): SD ACCESS Charge indicator (color: orange): CHARGE	
Operation interface	Touch screen	Method	Resistance film		
		Life expectancy <sup>2</sup>	1,000,000 operations		
External interface	Ethernet	100BASE-TX/10BASE-T			
	SD card	SDHC-compliant, Class 4 or higher recommended			
Ratings	Power supply voltage	DC power connection: 21.6 to 26.4 VDC (including ripple)		DC power connection: 21.6 to 26.4 VDC (including ripple) AC adapter (manufactured by Sino-American Japan Co., Ltd) connection: 100 to 240 VAC, 50/60 Hz Battery connection: FQ-BAT1 Battery (1 cell, 3.7 V)	
	Continuous operation on Battery <sup>3</sup>	---		1.5 h	
	Current consumption	DC power connection: 0.2 A max.		DC power connection: 0.2 A max., Charging battery: 0.4 A max.	
	Insulation resistance	Between all lead wires and case: 0.5 MΩ (at 250 V)			

Item		Model with DC power supply	Model with AC/DC/battery power supply
		FQ2-D30	FQ2-D31
Environmental immunity	Ambient temperature range	Operating: 0 to 50°C Storage: -25 to 65°C (with no icing or condensation)	Operating: 0 to 50°C when mounted to DIN Track or panel 0 to 40°C when operated on a Battery Storage: -25 to 65°C (with no icing or condensation)
	Ambient humidity range	Operating and storage: 35% to 85% (with no condensation)	
	Ambient atmosphere	No corrosive gas	
	Vibration resistance (destruction)	10 to 150 Hz, single amplitude: 0.35 mm, X/Y/Z directions 8 min each, 10 times	
	Shock resistance (destruction)	150 m/s <sup>2</sup> 3 times each in 6 direction (up, down, right, left, forward, and backward)	
	Degree of protection	IEC 60529 IP20	
Weight		Approx. 270 g (without Battery and hand strap)	
Dimensions		95 × 85 × 32.5 mm	
Materials		Case: ABS	
Accessories		Touch Pen (FQ-XT), Instruction Manual	

\*1 This is a guideline for the time required for the brightness to diminish to half the initial brightness at room temperature and humidity. No guarantee is implied. The life of the backlight is greatly affected by the ambient temperature and humidity. It will be shorter at lower or higher temperatures.

\*2 This value is only a guideline. No guarantee is implied. The value will be affected by operating conditions.

\*3 This value is only a guideline. No guarantee is implied. The value will be affected by the operating environment and operating conditions.

## • Battery Specifications

Item	FQ-BAT1
Battery type	Secondary lithium ion battery
Nominal capacity	1,800 mAh
Rated voltage	3.7 V
Dimensions	35.3 × 53.1 × 11.4 mm
Ambient temperature range	Operating: 0 to 40°C Storage: -25 to 65°C (with no icing or condensation)
Ambient humidity range	Operating and storage: 35% to 85% (with no condensation)
Charging method	Charged in Touch Finder (FQ-D31).
Charging time <sup>*1</sup>	2 h
Usage time <sup>*1</sup>	1.5 h
Battery backup life <sup>*2</sup>	300 charging cycles
Weight	50 g max.

\*1 This value is only a guideline. No guarantee is implied. The value will be affected by operating conditions

\*2 This is a guideline for the time required for the capacity of the Battery to be reduced to 60% of the initial capacity. No guarantee is implied. The value will be affected by the operating environment and operating conditions.

## Dimensions

### FQ2-D30/-D31

(Unit: mm)

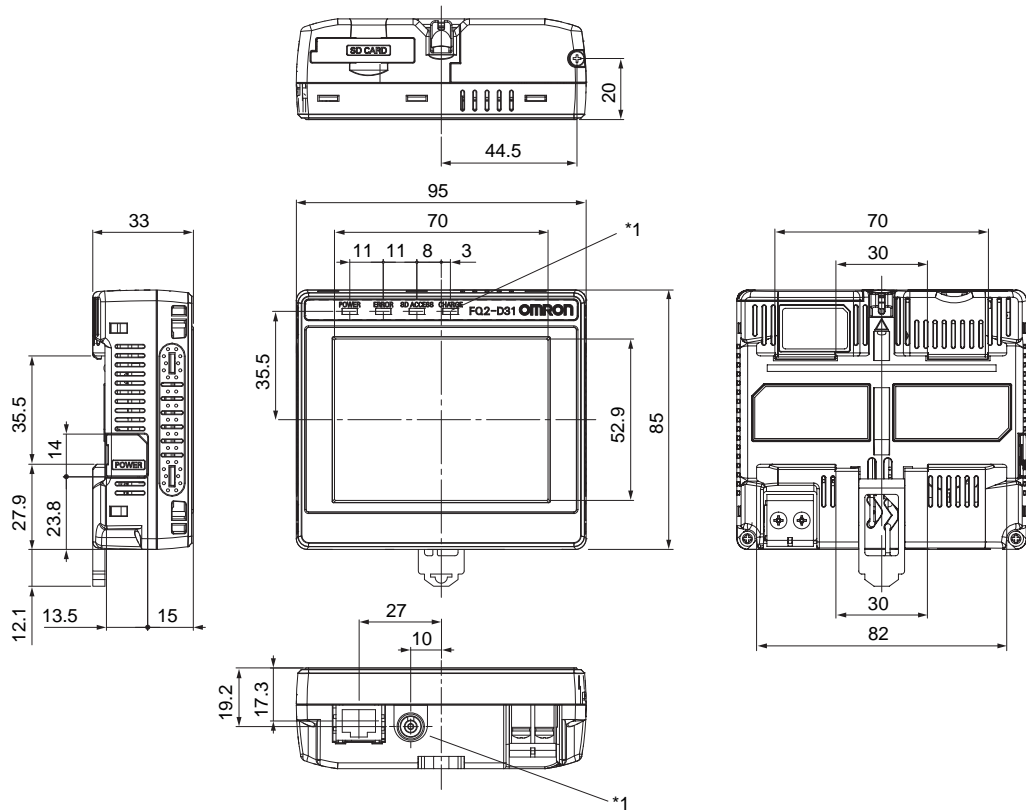

\*1: Provided on the FQ2-D31 only.

## Panel Mounting Adapter (FQ-XPM)

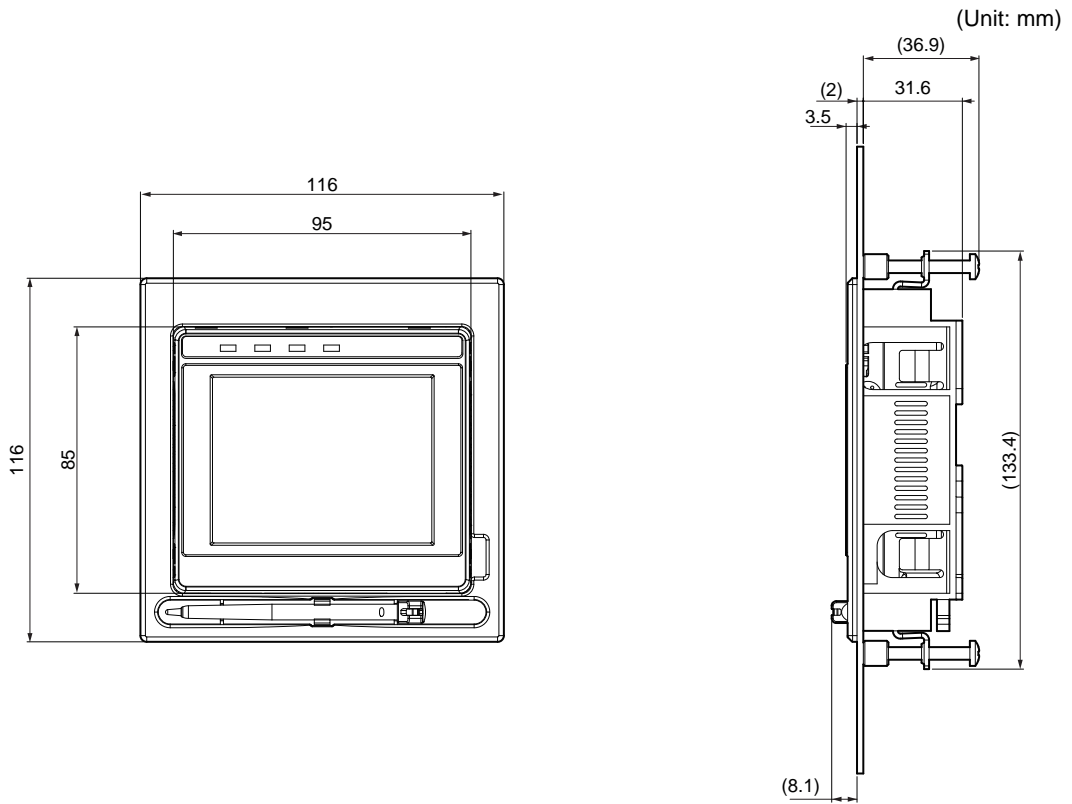

## Panel cutout dimensions

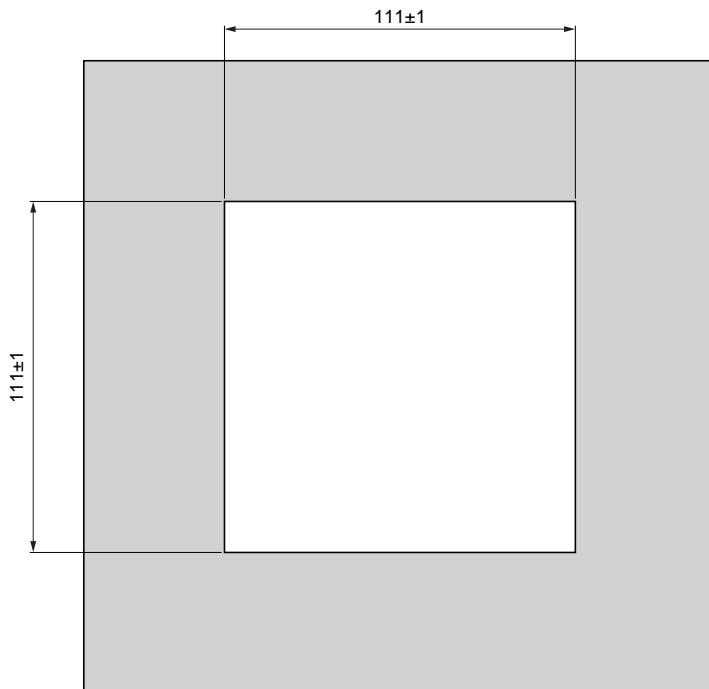



# Sensor Data Units

## Specifications

Item			Sensor Data Units
			FQ-SDU1□ Parallel Interface Sensor Data Unit (SDU10: NPN, SDU15: PNP) FQ-SDU2□ RS-232C Interface Sensor Data Unit (SDU20: NPN, SDU25: PNP)
I/O specifications	Parallel I/O	SDU1□	11 inputs (TRIG, RESET, IN0 to IN7, and DSA) 24 outputs (GATE, D0 to D15, ACK, RUN, BUSY, OR, ERROR, STGOUT, and SHTOUT)
		SDU2□	8 inputs (IN0 to IN5, TRIG, and RESET) 7 outputs (ACK, RUN, BUSY, OR, ERROR, STGOUT, SHTOUT)
	RS-232C		1 channel, 115,200 bps max. *FQ-SDU2□ only.
	Sensor interface		FQ2-S3 connected with FQ-WU□□□□: OMRON interface *Number of connected Sensors: 1
	Input specifications		Refer to Table 2.
	Output specifications		
Ratings	Power supply voltage		21.6 to 26.4 VDC (including ripple)
	Insulation resistance		Between all DC external terminals and case: 0.5 MΩ min. (at 250 VDC)
	Current consumption		2.5 A max. (FQ2-S□□□□□□□□-□□□□ + FQ-SDU□□) 0.4 A max. (FQ2-S3□-□□□□ + FQ-SDU□□) 0.1 A max. (for FQ-SDU□□)
Environmental immunity	Ambient temperature range		Operating: 0 to 50°C, Storage: -20 to 65°C (with no icing or condensation)
	Ambient humidity range		Operating and storage: 35% to 85% (with no condensation)
	Ambient atmosphere		No corrosive gas
	Vibration resistance (destruction)		10 to 150 Hz, single amplitude: 0.35 mm, X/Y/Z directions, 8 min each, 10 times
	Shock resistance (destruction)		150 m/s <sup>2</sup> 3 times each in 6 directions (up, down, right, left, forward, and backward)
	Degree of protection		IEC 60529 IP20
Materials			Case: PC + ABS, PC
Size			62 × 90 × 65 (W×H×D) (Excluding connectors, DIN Track, and protrusions.)
Weight			Approx. 150 g
Accessories			Instruction Manual

Table 1

Item	NPN	PNP
Input specifications	ON: Shorted to 0 V, or 1.5 V max. OFF: Open (leakage current: 0.1 mA max.)	ON: Shorted to power supply voltage, or power supply voltage -1.5 V max. OFF: Open (leakage current: 0.1 mA max.)
Output specifications <sup>1</sup>	NPN open collector 30 VDC, 50 mA max., residual voltage: 1.2 V max.	PNP open collector 30 VDC, 50 mA max., residual voltage: 1.2 V max.

\*1: Do not allow the load current to exceed 50 mA. The output circuit may be damaged if the load current exceeds 50 mA.

## Dimensions

FQ-SDU10/-SDU15

(Unit: mm)

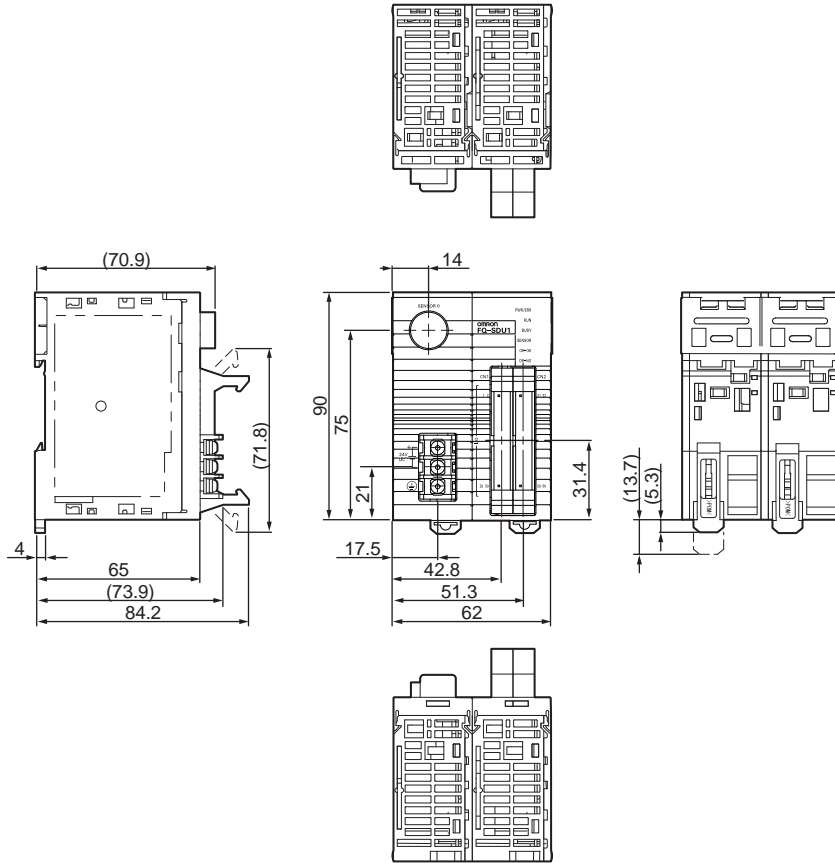

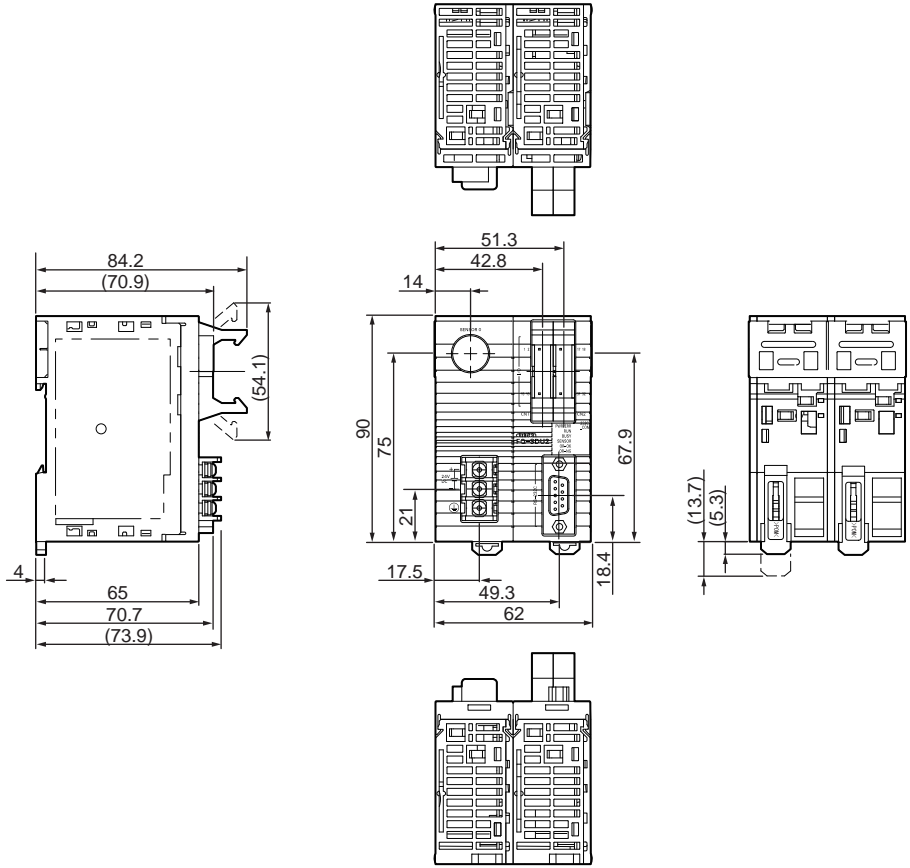

## System Requirements for PC Tool for FQ

The system requirements for the PC Tool are given in the following table.

Item	Requirement
OS	<ul style="list-style-type: none"> <li>Microsoft Windows XP Home Edition/Professional SP2 or higher (32-bit edition)</li> <li>Microsoft Windows 7 Home Premium or higher (32-bit edition or 64-bit edition)</li> </ul>
Hardware	<ul style="list-style-type: none"> <li>CPU: Core 2 Duo 1.06 GHz or the equivalent or higher</li> <li>RAM: 1 GB min.</li> <li>HDD: 500 MB min. available space<sup>*1</sup></li> <li>Monitor: 1,024 x 768 dots min.</li> </ul>

\*1. Available space is also required separately for data logging.

## Options

### Specifications

#### • I/O Cables

Item	Model	FQ-WD002	FQ-WD010	FQ-WD020
Cable length		2 m	10 m	20 m
Cable type		Robot cable		
Wire gauge	Power line	AWG24	AWG24 to AWG20	
	Other lines	AWG28		
Cable diameter		6.4	6.4 to 6.7	
Minimum bending radius		41.4 mm		
Weight		100 g	500 g	1500 g

#### • FQ Ethernet Cable

Item	Model	FQ-WN002	FQ-WN010	FQ-WN020
Cable length		2 m	10 m	20 m
Cable type		Robot cable		
Minimum bending radius		40 mm		
Weight		125 g	620 g	1780 g

#### • Parallel Cable for FQ-SDU1

Item	Model	FQ-VP1002	FQ-VP1005	FQ-VP1010
Applicable Units		FQ-SDU1□		
Cable length		2 m	5 m	10 m
Cable type		Flat cable		
Minimum bending radius		5.5 mm		
Weight		150 g	380 g	750 g

#### Important

Do not bend any Cable beyond the specified minimum bending radius. Doing so may damage the Cable.

• **Parallel Cable for FQ-SDU2**

Item	Model	FQ-VP2002	FQ-VP2005	FQ-VP2010
Applicable Units		FQ-SDU2□		
Cable length		2 m	5 m	10 m
Cable type		Flat cable		
Minimum bending radius		5.5 mm		
Weight		80 g	200 g	400 g

• **Sensor Data Unit Cable**

Item	Model	FQ-WU002	FQ-WU005	FQ-WU010	FQ-WU020
Cable length		2 m	5 m	10 m	20 m
Cable type		Robot cable			
Cable diameter		7			
Minimum bending radius		35 mm			
Weight		200 g	400 g	800 g	1500 g

**Important**

Do not bend any Cable beyond the specified minimum bending radius. Doing so may damage the Cable.

• **AC Adapter**

Item	Model	FQ-AC1	FQ-AC2	FQ-AC3	FQ-AC4	FQ-AC5	FQ-AC6
Plug type		A	A	A	C	BF	O
Certified standards		PSE	UL/CSA	CCC mark	---	---	---
Input voltage		100 to 240 VAC (90 to 264 VAC)					
Input current		0.4 A max., 100 VAC, 50 Hz when connected to maximum load					
Input frequency		47 to 63 Hz					
Output voltage		15 VDC±5%					
Output current		1 A max.					
Ambient temperature range		Operating: 0 to 40°C Storage: -20 to 65°C (with no icing or condensation)					
Ambient humidity range		Operating and storage: 35% to 80% (with no condensation)					
Material		Case: PPE					
Cable length		1.5 m					
Dimensions		78 × 50 × 30 mm (without power cable)					
Weight		Approx. 270 g					
Contents of label on AC Adapter							

## Dimensions

### I/O Cables

FQ-WD002

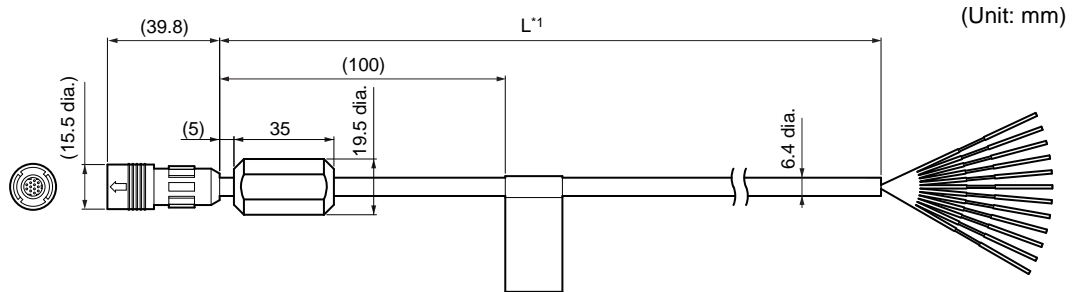

\*1: The cable length is given in the following table.

Model	L
FQ-WD002	2 m

FQ-WD010/WD020

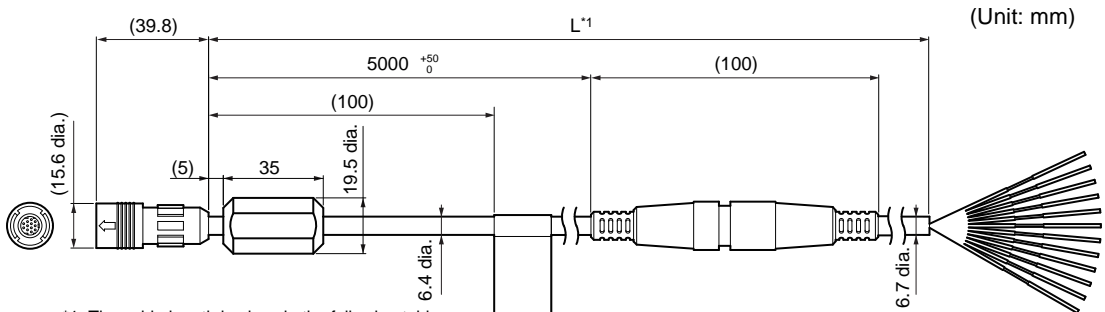

\*1: The cable length is given in the following table.

Model	L
FQ-WD010	10 m
FQ-WD020	20 m

### FQ Ethernet Cable

FQ-WN002/WN010/WN020

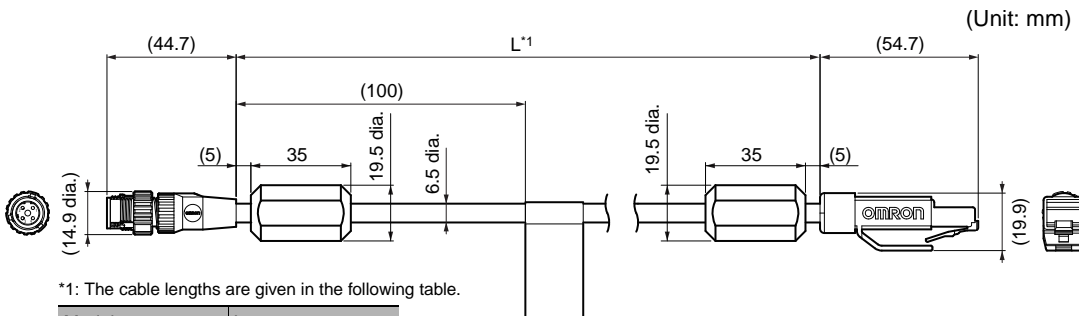

\*1: The cable lengths are given in the following table.

Model	L
FQ-WN002	2 m
FQ-WN010	10 m
FQ-WN020	20 m

• **Sensor Data Unit Cable**

FQ-WU002/WU005/WU010/WU020

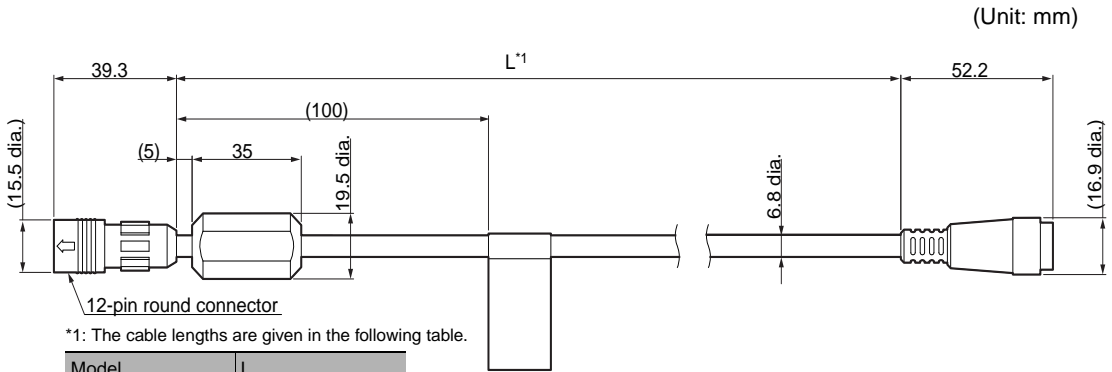

Model	L
FQ-WU002	2 m
FQ-WU005	5 m
FQ-WU010	10 m
FQ-WU020	20 m

• **Parallel Cable for FQ-SDU1**

FQ-VP1002/VP1005/VP1010

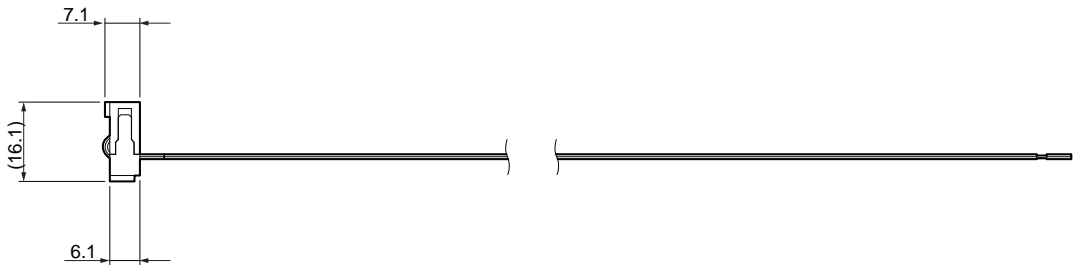
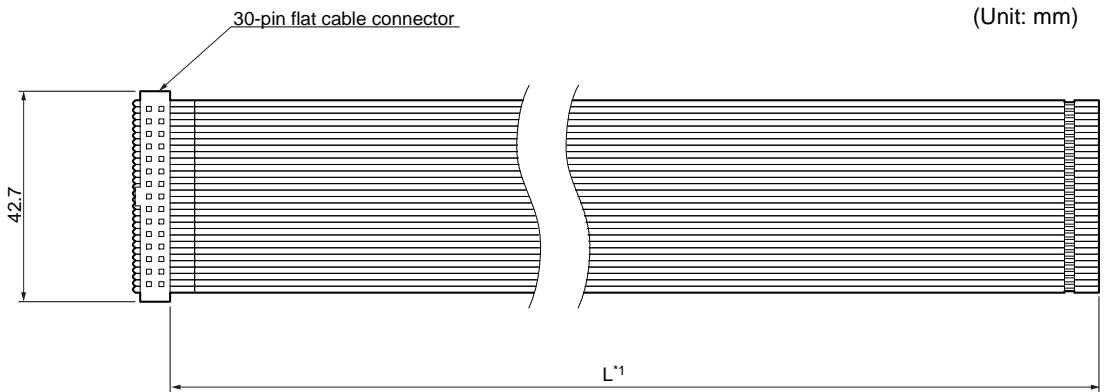

\*1: The cable lengths are given in the following table.

Model	L
FQ-VP1002	2 m
FQ-VP1005	5 m
FQ-VP1010	10 m

• **Parallel Cable for FQ-SDU2**

FQ-VP2002/VP2005/VP2010

(Unit: mm)

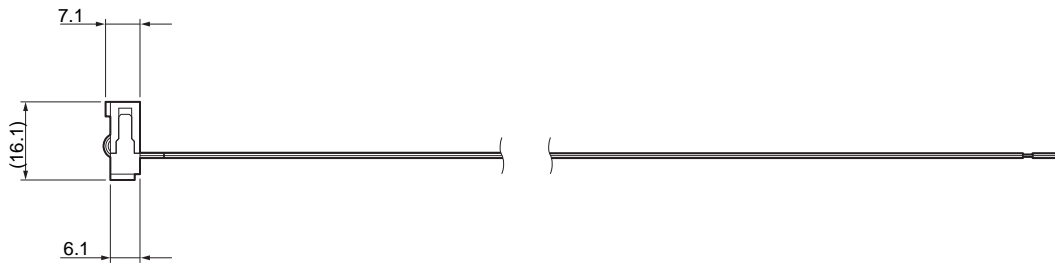
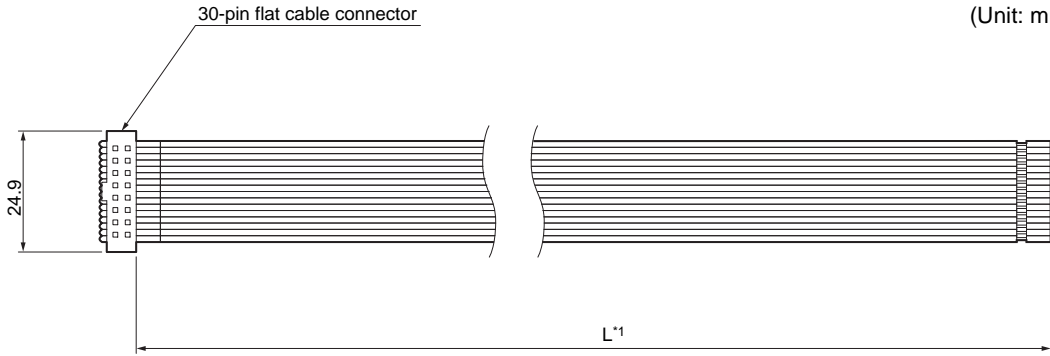

\*1: The cable lengths are given in the following table.

Model	L
FQ-VP2002	2 m
FQ-VP2005	5 m
FQ-VP2010	10 m

• **AC Adapter**

FQ-AC1

(Unit: mm)

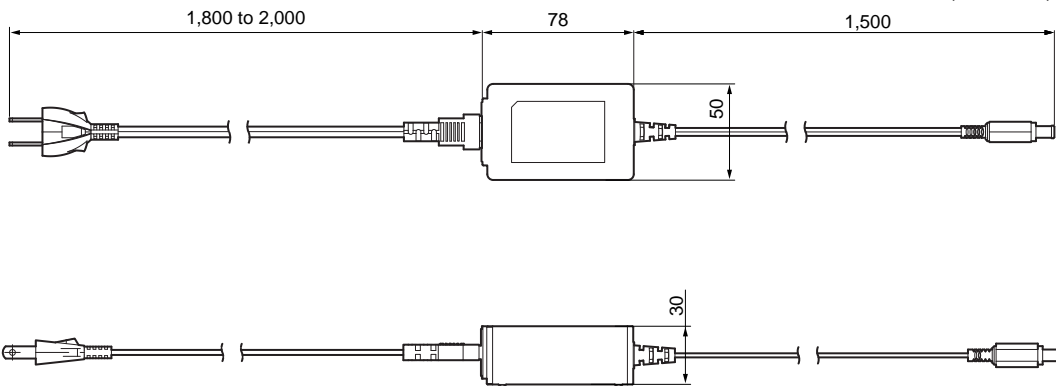



# 12-4 Updating the Software

The most recent version of the software and PC Tool can be downloaded from the following website for OMRON members. Refer to the *Member Registration Sheet* that is enclosed with the Sensor.

[http://www.omron-cxone.com/vision\\_sys](http://www.omron-cxone.com/vision_sys)

After you download the software, use the following procedure to update.

When you update the software, always update the software for the Touch Finder or PC Tool first, and then update the software for the Sensor.

## Step 1 Update the software for the PC Tool or Touch Finder.

- Update the PC Tool

Install the PC Tool that was downloaded.

- Update the software for the Touch Finder

- 1** Place the update file that you obtained directly in the root folder of an SD card.
- 2** Insert the SD card into the Touch Finder.
- 3** Press  (Setup Mode) - [TF settings] - [Update].

## Step 2 Update the software for the Sensor.

- Updating from the PC Tool

- 1** Store the update file you obtained in the following directory.  
\\...\My Documents\OMRON FQ\SDCard\UPDATE\SENSOR
- 2** To update the software in the Sensor, press  (Setup Mode) - [Sensor settings] - [Update].

- Updating from the Touch Finder

- 1** Place the update file that you obtained directly in the root folder of the SD card.
- 2** Insert an SD card into the Touch Finder.
- 3** To update the software in the Sensor, press  (Setup Mode) - [Sensor settings] - [Update].

The software will be updated automatically.

### Important

Do not turn OFF the power supply until updating the software has been completed.

The Sensor or Touch Finder may not start normally if power is turned OFF during the update.

## 12-5 Connecting a Previous Touch Finder (FQ-D30/D31) to the FQ2-S Sensor

If you update the previous FQ-D30/D31 Touch Finder to version 1.6 or higher, you can connect it to an FQ2-S Sensor. However, the memory size that is required to use all of the filter items, position compensation items, and inspection items exceeds the memory capacity of the previous FQ-D30/D31 Touch Finder, so you will not be able to use all of the filter items, position compensation items, and inspection items that are provided in the FQ2-S Sensor.

Therefore, it is necessary to select only the filter items, position compensation items, and inspection items that you need to use and register them in the Sensor.

If you connect the Touch Finder without doing this, the Touch Finder may freeze as soon as it is connected or during operation.

Apart from the filter items, position compensation items, and inspection items, you can use all of the functions of the Sensor.

Download the update file for the Touch Finder (version 1.6 or higher) and the FQ Item Selector from the member website, and then use the following procedures to update the Touch Finder and register the filter items, position compensation items, and inspection items in the Sensor.

[http://www.omron-cxone.com/vision\\_sys](http://www.omron-cxone.com/vision_sys)

### • Updating the Touch Finder

- 1 Place the update file directly in the root folder of an SD card.**
- 2 Insert the SD card into the Touch Finder.**
- 3 Press  (Setup Mode) - [TF settings] - [Update].**

The Touch Finder will be updated automatically.

### Important

Do not turn OFF the power supply until updating the Touch Finder has been completed. The Touch Finder may not start normally if power is turned OFF during the update.

- Re-registering Inspection Items, Filter Items, and Position Compensation Items in the Sensor

Re-register the inspection items, filter items, and position compensation items in the Sensor using the FQ Item Selector. Unpack the FQ Item Selector file that you downloaded, execute the setup.exe file, and install the FQ Item Selector.

### Important

Perform the following procedure without starting the PC Tool for FQ. If you start the PC Tool, Sensor detection and overwriting the file will not be performed normally.

- 1 Connect the Sensor to the PC.
- 2 Select [All Programs] - [OMRON] - [FQ] - [Tool] - [FQ Item Selector] from the Windows Start Menu to start the FQ Item Selector.
- 3 Select the language to display.
- 4 Select the model of Touch Finder to use.

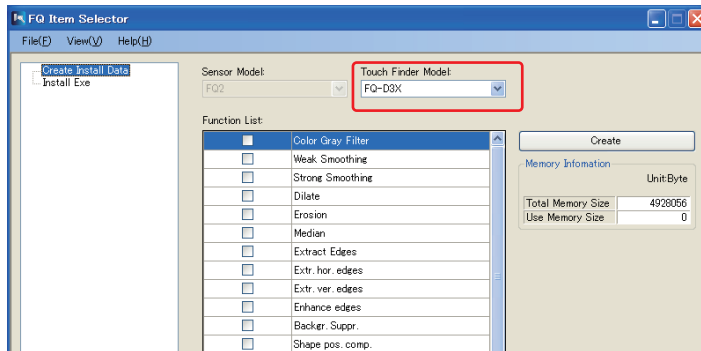

- 5 Select the inspection items to use.

The memory size that is required to use the selected inspection items will be displayed. You must select inspection items so that the total memory size of the Touch Finder is not exceeded.

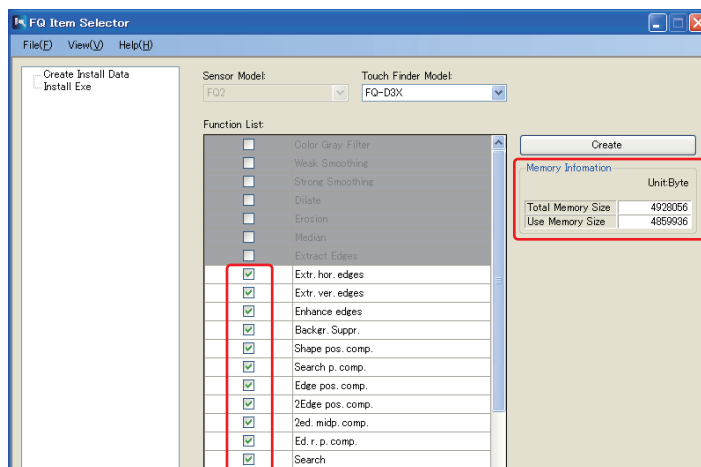

**Note**

**Grayed-out Inspection Items**

If selecting an inspection item would cause the total memory size to be exceeded, that inspection item will be grayed-out on the display. Select the inspection items with the highest priority first. The Touch Finder will be updated automatically.

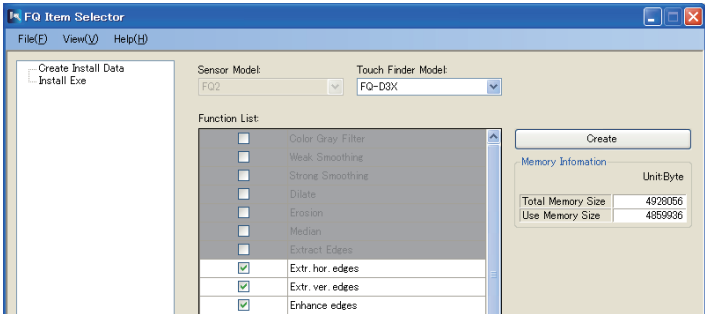

**6 Click the [Create] Button to save the installation data.**

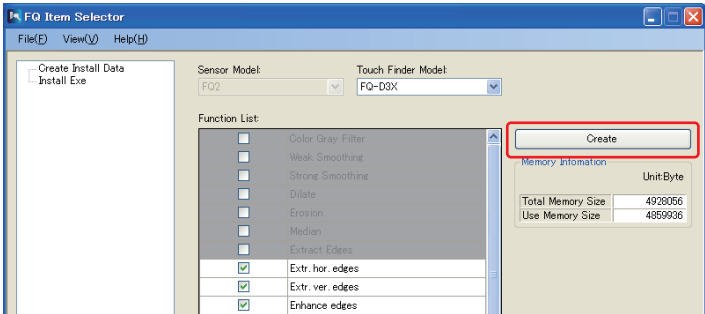

**7 Click [Install Exe].**

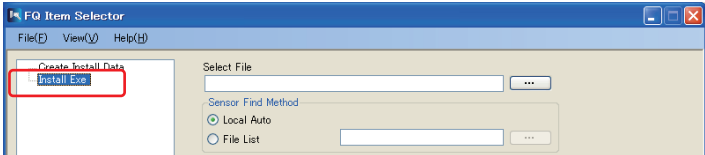

- 8 Select the Browse Button (...) and select the file that was saved in step 6, above.

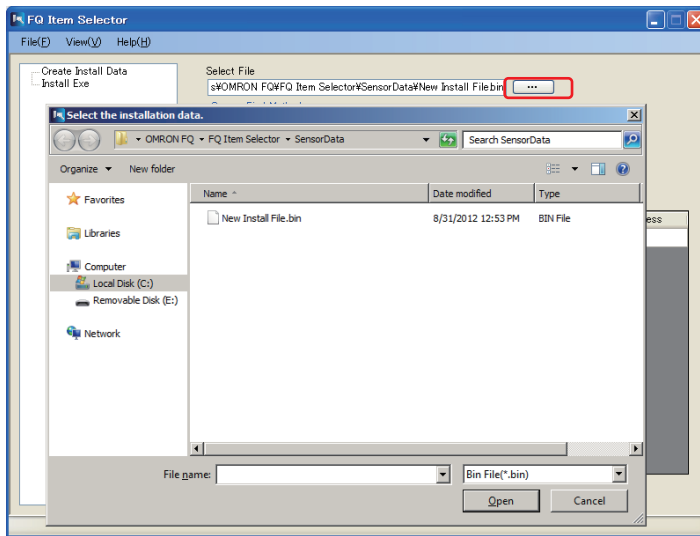

- 9 Set the Sensor Find Method parameter to [Local Auto].

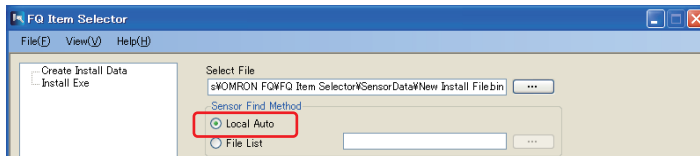

- 10 If there is more than one network card (NIC) installed in the PC, select the NIC that is connected to the Sensor.  
More than one NIC will be displayed for a PC with a wireless LAN.

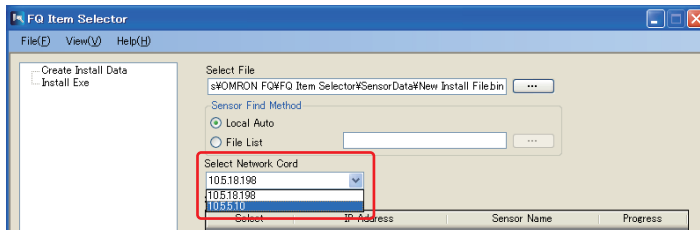

## 11 Click the [Update Sensor List] Button.

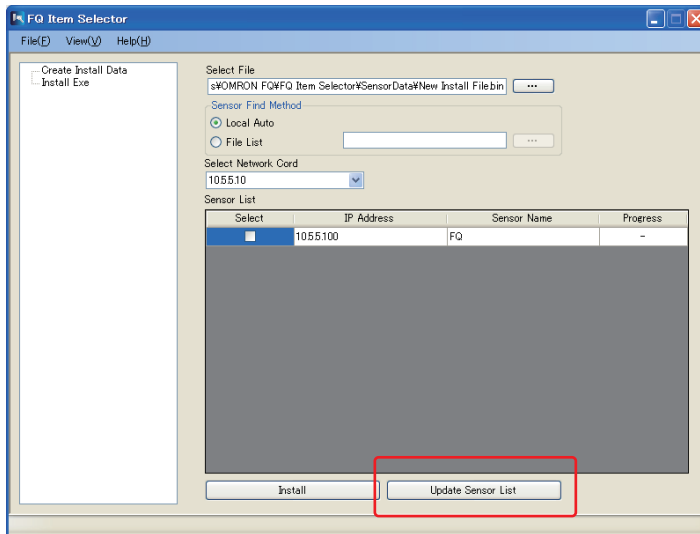

## 12 Select the Sensor from the list and click the [Install] Button.

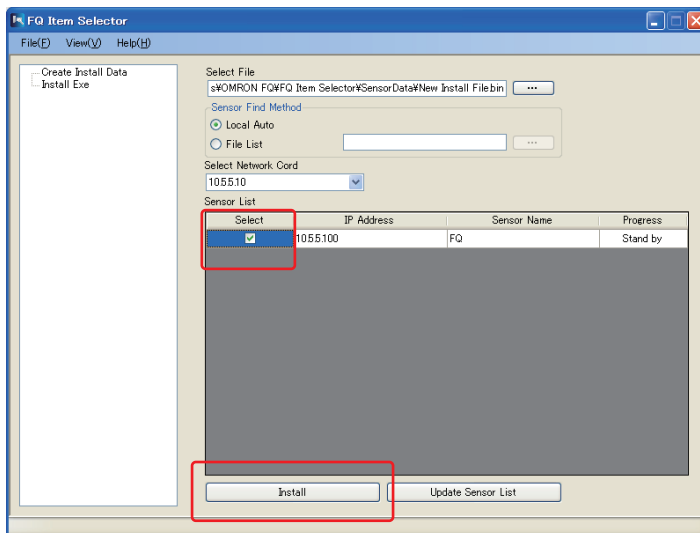

If *Installation completed normally* is displayed in the dialog box, the data has been overwritten normally.

## 13 Reset the Sensor.

### • Restoring Inspection Items to the Sensor

It is not necessary to delete any inspection items to connect the FQ2-D30/D31 Touch Finder. To connect the FQ2-D30/D31 Touch Finder after performing the above operation, repeat the above operation, but select all of the inspection items in step 5 to re-register all of the inspection items in the original state.

# 12-6 LED Safety

For LED devices, class classification to indicate dangerous level and safety standards are stipulated in respective countries. Take necessary safety preventive measures according to the standards.

## Warning Label

Warning labels are supplied as accessories with products that comply with the Class 2 Laser Product Classification. Attach them to appropriate positions near the Sensor where they can be easily noticed.

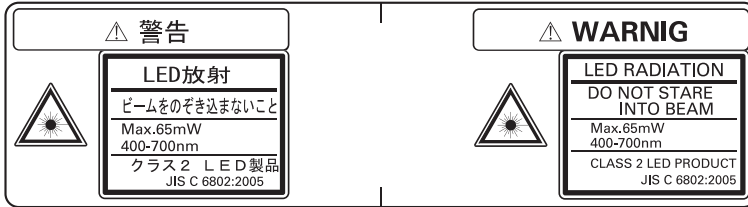

# 12-7 Requirements from Regulations and Standards

## Summary of Requirements to Manufactures

### For Europe

EN 60825-1 "Safety of Laser Products, Equipment Classification, Requirements and User's Guide"  
Summary of Manufacturer's Requirements

Requirements subclause	Classification						
	Class 1	Class 1M	Class 2	Class 2M	Class 3R	Class 3B	Class 4
Description of hazard class	Safe under reasonably foreseeable conditions	As for Class 1 except may be hazardous if user employs optics	Low power; eye protection normally afforded by aversion responses	As for Class 2 except may be more hazardous if user employs optics	Direct intra-beam viewing may be hazardous	Direct intra-beam viewing normally hazardous	High power; diffuse reflections may be hazardous
Protective housing	Required for each laser product; limits access necessary for performance of functions of the products						
Safety interlock in protective housing	Designed to prevent removal of the panel until accessible emission values are below that for Class 3R				Designed to prevent removal of the panel until accessible emission values are below that for Class 3B		
Remote control	Not required					Permits easy addition of external interlock in laser installation	
Key control	Not required					Laser inoperative when key is removed	
Emission warning device	Not required				Give audible or visible warning when laser is switched on or if capacitor bank of pulsed laser is being charged. For Class 3R only, applies invisible radiation is emitted		
Attenuator	Not required					Give means beside the On/Off switch to temporarily block beam	
Location controls	Not required				Controls so located that there is no danger of exposure to AEL above Classes 1 or 2 when adjustments are made		
Viewing optics	Not required	Emission from all viewing systems must be below Class 1M AEL					
Scanning	Scan failure shall not cause product to exceed its classification						
Class label	Required wording		Figures A required wording				
Aperture label	Not required				Specified wording required		
Service entry label	Required as appropriate to the class of accessible radiation						
Override interlock label	Required under certain conditions as appropriate to the class of laser used						
Wavelength range label	Required for certain wavelength ranges						
LED label	Make required word substitutions for LED products						
User information	Operation manuals must contain instructions for safe use. Additional requirement apply for Class 1M and Class 2M						
Purchasing and service information	Promotion brochures must specify product classification; service manuals must contain safety information						

**Note:** 1. This table is intended to provide a convenient summary of requirements. See text of this standard for complete requirements.

2. For the safety medical laser products, IEC 60601-2-22 applies.

3. AEL: Accessible Emission Limit



The maximum accessible emission level permitted within a particular class. For your reference, see ANSI Z136.1-1993, Section 2.

Symbol and border: black  
Background: yellow

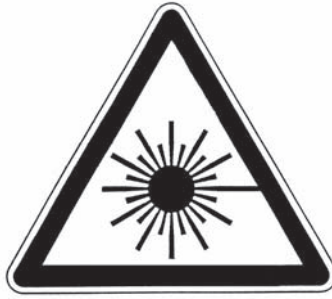

**Figure A Warning label - Hazard symbol**

# Summary of Requirements to User

## For Europe

### EN 60825-1

Requirements sub-clause	Classification						
	Class 1	Class 1M	Class 2	Class 2M	Class 3R	Class 3B	Class 4
Laser safety officer	Not required but recommended for applications that involve direct viewing of the laser beam				Not required for visible emission Required for non-visible emission	Required	
Remote interlock	Not required					Connect to room or door circuits	
Key control	Not required					Remove key when not in use	
Beam attenuator	Not required					When in use prevents inadvertent exposure	
Emission indicator device	Not required				Indicates laser is energized for non-visible wavelengths	Indicates laser is energized	
Warning signs	Not required					Follow precautions on warning signs	
Beam path	Not required	Class 1M as for Class 3B (see note 2)	Not required	Class 2M as for Class 3B (see note 3)	Terminate beam at end of useful length		
Specular reflection	No requirements	Class 1M as for Class 3B (see note 2)	No requirements	Class 2M as for Class 3B (see note 3)	Prevent unintentional reflections		
Eye protection	No requirements				Not required for visible emission Required for non-visible emission	Required if engineering and administrative procedures not practicable and MPE exceeded	
Protective clothing	No requirements					Sometimes required	Specific requirements
Training	No requirements	Class 1M as for Class 3R (see note 2)	No requirements	Class 2M as for Class 3R (see note 3)	Required for all operator and maintenance personnel		

**Note:** 1. This table is intended to provide a convenient summary of requirements. See text of this standard for complete precautions.

2. Class 1M laser products that failed condition 1 of table 10 of the standard. Not required for Class 1M laser products that failed condition 2 of table 10 of the standard. See the text for details.

3. Class 2M laser products that failed condition 1 of table 10 of the standard. Not required for Class 2M laser products that failed condition 2 of table 10 of the standard. See the text for details.

# Definitions of Laser Classification

## For Europe

### Laser Product Classifications

#### EN

Class	Description
Class 1	Laser that are safe under reasonably foreseeable conditions of operation, including the use of optical instruments for intrabeam viewing.
Class 1M	Laser emitting in the wavelength range from 302.5 nm to 4000 nm which are safe under reasonably foreseeable conditions of operation, but may be hazardous if the user employs optics within the beam.
Class 2	Laser that emit visible radiation in the wavelength range from 400 nm to 700 nm where eye protection is normally afforded by aversion responses, including the blink reflex. This reaction may be expected to provide adequate protection under reasonably foreseeable conditions of operation including the use of optical instruments for intrabeam viewing.
Class 2M	Laser that emit visible radiation in the wavelength range from 400 nm to 700 nm where eye protection is normally afforded by aversion responses, including the blink reflex. However, viewing of the output may be more hazardous if the user employs optics within the beam.
Class 3R	Laser that emit in the wavelength range from 302.5 nm to 10 <sup>6</sup> nm where direct intrabeam viewing is potentially hazardous but the risk is lower than for Class 3B lasers, and fewer manufacturing requirements and control measures for the user apply than for Class 3B lasers. The accessible emission limit is within five times the AEL of Class 2 in the wavelength range from 400 nm to 700 nm and within five times the AEL of Class 1 for other wavelengths.
Class 3B	Lasers that are normally hazardous when direct intrabeam exposure occurs (i.e. within the NOHD). Viewing diffuse reflections is normally safe (see also note).
Class 4	Lasers which are also capable of producing hazardous diffuse reflections. They may cause skin injuries and could also constitute a fire hazard. Their use requires extreme caution.

**Note:** Conditions for safe viewing of diffuse reflections for Class 3B visible lasers are: minimum viewing distance of 13 cm between screen and cornea and a maximum viewing time of 10 s. Other viewing conditions require a comparison of the diffuse reflection exposure with the MPE.

# 12-8 Detailed EtherNet/IP Communications Specifications

This section lists the objects that are mounted in the Sensor.

## 1-1 01h Identity Object

### Class Attributes

ID	Access	Name	Data type	Description	Attribute value
1	Get	Revision	UINT	Revision of the object	1
2	Get	Max Instance	UINT	Maximum instance number	1
3	Get	Number of Instances	UINT	Number of object instances	1
4	Get	Revision	Structure	Revision of Identity object	1.1
		Major Revision	UINT	Major revision	1
		Minor Revision	UINT	Minor revision	1
7	Get	Maximum ID Number Instance Attributes	UINT	Attribute ID of instance attributes	7

### Instance Attributes

ID	Access	Name	Data type	Description	Attribute value
1	Get	Vendor ID	UINT	Vendor ID	47
2	Get	Device Type	UINT	General device type	43
3	Get	Product Code	UINT	Product code	1645
4	Get	Revision	Structure	Revision of Identity object	1.1
		Major Revision	UINT	Major revision	1
		Minor Revision	UINT	Minor revision	1
5	Get	Status	WORD	Current status of device	
6	Get	Serial Number	UDINT	Serial number	Lower 4 bytes of MAC address
7	Get	Product Name	SHORT- STRING	Product name	"FQ Series"

### Services

Code	Service name	Class	Instances	Remarks
01 hex	Get_Attribute_All	Yes	Yes	
05 hex	Reset	No	Yes	Parameter: 0, 1
0E hex	Get_Attribute_Single	Yes	Yes	

## 1-2 02h Message Router Object

Class Attributes

None

Instance Attributes

None

Services

None

## 1-3 06h Connection Manager

Class Attributes

None

Instance Attributes

None

Services

Code	Service name	Class	Instances	Remarks
54 hex	Forward Open	No	Yes	
4E hex	Forward Close	No	Yes	

## 1-4 F5h TCP/IP Interface

Class Attributes

ID	Access	Name	Data type	Description	Attribute value
1	Get	Revision	UINT	Revision of the object	1
2	Get	Max Instance	UINT	Maximum instance number	1
3	Get	Num Instance	UINT	Number of object instances	1

Instance Attributes

ID	Access	Name	Data type	Description	Attribute value
1	Get	Status	DWORD	Interface status	0x0002 (Depends on the device.)
2	Get	Configuration Capability	DWORD	Interface Function Flag	0x0002 (Depends on the device.)
3	Get/Set	Configuration Control	DWORD	Interface Control Flag	0x0000
4	Get	Physical Link Object	STRUCT of:	Path to the link object in the physical layer	---
		Path size	UINT	Path size	2
		Path	Padded EPATH	Segment to identify physical-layer linked object	20 F6 24 01

ID	Access	Name	Data type	Description	Attribute value
5	Get	Interface Configuration	STRUCT of:	TCP/IP network interface settings	
		IP Address	UDINT	IP address of the device	
		Network Mask	UDINT	Network mask of the device	
		Gateway Address	UDINT	Default gateway address	
		Name Server	UDINT	Primary name server	
		Name Server 2	UDINT	Secondary name server	
		Domain Name	STRING	Default domain name	
6	Get	Host Name	STRING	Host name	

#### Services

Code	Service name	Class	Instances	Remarks
01 hex	Get_Attribute_All	No	Yes	
02 hex	Set_Attribute_All	No	Yes	
0E hex	Get_Attribute_Single	No	Yes	
10 hex	Set_Attribute_Single	No	Yes	

### 1-5 F6h Ethernet Link

#### Class Attributes

ID	Access	Name	Data type	Description	Attribute value
1	Get	Revision	UINT	Revision of the object	1
2	Get	Max Instance	UINT	Maximum instance number	1
3	Get	Num Instance	UINT	Number of ports for which instances are created	1

#### Instance Attributes

ID	Access	Name	Data type	Description	Attribute value
1	Get	Interface Speed	UDINT	Interface baud rate	
2	Get	Interface Flags	DWORD	Interface Status Flag	
3	Get	Physical Address	ARRAY of 6 USINTs	MAC-layer address	

#### Services

Code	Service name	Class	Instances	Remarks
01 hex	Get_Attribute_All	No	Yes	
0E hex	Get_Attribute_Single	Yes	Yes	

## 1-6 04h Assembly Object

### Class Attributes

ID	Access	Name	Data type	Description	Attribute value
1	Get	Revision	UINT	Revision of the object	2

### Instance Attributes (O to T), Instance ID: 100

ID	Access	Name	Data type	Description	Attribute value
3	Get/Set	Data	BYTE array	Byte data (Data format is defined by application.)	Refer to <i>Memory Assignments</i> (input connection to Sensor).
4	Get	Size	UINT	Number of bytes	O to T data size (Set before going online.)

### Instance Attributes (T to O), Instance ID: 101

ID	Access	Name	Data type	Description	Attribute value
3	Get	Data	BYTE array	Byte data (Data format is defined by application.)	Refer to <i>Memory Assignments</i> (input connection to Sensor).
4	Get	Size	UINT	Number of bytes	O to T data size (Set before going online.)

### Services

Code	Service name	Class	Instances	Remarks
0E hex	Get_Attribute_Single	Yes	Yes	
10 hex	Set_Attribute_Single	No	Yes	

# Index

<b>A</b>	
AC Adapter	487
AC power supply connector	
Touch Finder	31
ACK	45, 47
ACK signal ON period	270
adjusting parameters	
adjustment in Run Mode	187
adjustment during operation	187
all color images	143, 149
All Region	183
All Sensor data	218
Angle	96, 106, 114
Angle range	99, 109, 116
Area	142, 148
area	140
auto connect	22
Average pitch	133
Average width	133
<b>B</b>	
B average	138
Background Suppression	70
backing up data	218
backlight	202
basic troubleshooting	401
Battery	51
specifications	480
battery level	230
binary images	143, 149
brightness	63, 137
brightness correction mode	61
BUSY	45, 47
BUSY Indicator	231
BUSY signal	234
BUSY signal output polarity	244
<b>C</b>	
calibration	193
calibration data	
saving	218
calibration group data	
saving	218
calibration pattern	194, 199
camera image	224
camera image file	201
Camera input	183
camera setup	60
capturing image	224
changing from BUSY indicator	231
changing line process using scenes	190
checking the error histories	399
clearing the error histories	399
C-mount cover	30
C-mount lens mounting surface	30
color	
setting	124, 142, 148
color data	136
Color deviation	138
color difference	138
Color Gray Filter	69
Color ON/OFF	124
color palette	124, 143, 149
COMIN0	45, 47
COMIN1	45, 47
COMOUT	45
COMOUT0	47
COMOUT1	45
configuration	93
connecting to more than one Sensor	204
connection	
automatic	22
connector cover	30
console	101
Correlation	96, 106, 114
correlation	95
Count	96, 106, 114
CSV	212
<b>D</b>	
D. Area	142
D0 to D15	45
data	
saving	218
saving to file	218
DC power supply connector	
Touch Finder	31
decimal symbol	212
Definitions of Laser Classification	501
deleting log	216
Density average	138
Density deviat. (density deviation)	138
detailed EtherNet/IP communications	
specifications	502
deviation area	142
DHCP	53
Dilate	69
DIN Track mounting section	32
display elements	23
display language	229
display patterns	225
All color image	143, 149
Binary image	143, 149
Measurement image	143, 149
Selected color image	143, 149
display settings	143, 149
display types	182
displaying image data	228
DSA	45
<b>E</b>	
ECO mode	202
edge level	122
Edge pitch	133
edge pitch	131
edge position	120



Edge position comp. (edge position compensation)	74
edge position compensation	80
edge rotation position compensation	85
edge width	127
Edge width (edge in width)	128
Enhance edges	69
Erosion	69
ERROR	45, 47
error histories	398
error history	
deleting	399
errors in error history	398
viewing	399
error messages	400
ERROR signal	251
errors	
clearing	246
errors in teaching	
labeling	154
errors stored in the error history	398
Ethernet	53
Ethernet cable	486
connector	29
Ethernet no-protocol commands	357
Ethernet port	
Touch Finder	31
external lighting	61, 67
external trigger	236
Extract Edges	69
Extract Horiz. Edges	69
Extract vertical edges	69

<b>F</b>	
field separator	212
file format	212
files	
logging	209
filter items	69
FINS commands	378
FINS/TCP no-protocol commands	376
focus	60
adjustment screw	60
formatting an SD Card	222
FQ Ethernet Cable	488
frame ground	44, 46
frozen images	200

<b>G</b>	
G average	138
Gain	63
GATE	45
Graphics	182
Graphics + Details	182
Gravity center X	148
Gravity center Y	148
Gravity X	142
Gravity Y	142
GUI	
language	229

<b>H</b>	
handshaking	266
HDR function	64
hiding the menu	202
high dynamic range	64
histograms	185
auto display	185
class	185
display range	185
hue	137

<b>I</b>	
I/O Cable	42
connector	29, 30
I/O Cables	486
I/O indicators	32
232C_COM	32
BUSY	32
OR-NG	32
OR-OK	32
POWER/ERROR	32
RUN	32
SENSOR	32
I/O monitor	203
image adjustment	68
image data	
logging	209
image input	
increasing speed	173
partial input	173
image input mode	174
images	
displaying last NG image	201
displaying saved images	201
frozen	200
live	200
updating	201
zooming in	200
zooming out	200
zooming to fit display	200
IN0 to IN5	47
IN0 to IN7	45
individual judgements	241
initializing	229
Sensor and Touch Finder	229
Input mode	416
inputs	
IN0 to IN5	42
TRIG	42
inspection items	90
Area	140
color palette	143, 149
teaching errors	145
Color Data	136
copying	94
deleting	94
Edge Pitch	131
Edge Position	120
color palette	124
teaching errors	126
Edge Width	127

teaching errors	130, 134
labeling	146
renaming	94
Search	95, 105, 113
teaching errors	104, 112
searching	95, 105, 113
installation	33
IP address	53, 55

## L

Labeling	146
language	229
LCD Backlight	202
lens models	36
Lens selection	35
Lighting control	271
live images	200
Log	201
logging	
deleting log	216
recent results	214
selecting data to be logged	210
settings	209
starting and stopping	213
Logging image file	201

## M

MAC address	422, 426
macro rings	38
masking	101
Master angle	148
Max. pitch (maximum pitch)	133
Max. width (maximum pitch)	133
measurement data	
logging	208
measurement images	143, 149
measurement region	102, 110, 117
measurement time	172
measurements	
continuous	237, 246
Median	69
Memory state	230
menus	
hiding	202
Min. pitch (minimum pitch)	133
Min. width (minimum pitch)	133
Model (model position compensation)	74
models	95
mounting	
control panel	39
DIN Track	39, 41
mounting base	30, 34
Mounting Bracket	29
mounting holes	30
Multi-point output	97
mutual interference	
prevention	67

## N

Negative	245, 270
noise level	123
no-protocol command	395

NPN	43, 49
Number of labels	148

## O

One-shot output	243
operation	179
operation indicators	30
BUSY	29, 30
CHARGE	31
ERROR	29, 30, 31
ETN	29, 30
OR	29, 30
POWER	31
SD ACCESS	31
Touch Finder	31
Vision Sensor	29
optical charts	33
optical diagrams	35
OR	45, 47
OR output	244
OR signal	234
OR/NOT	101
OUT0 to OUT3 output polarity	245
OUT1 Polarity	244
Output delay	243
Output mode	244
Output polarity	270
Output time	243
outputs	
BUSY	42
ERROR	42
OR	42
OUT0	42
OUT1	42
OUT2	42
overall judgement	240

## P

Panel Mounting Adapter	39, 482
Parallel Cable for FQ-SDU1	489
Parallel Cable for FQ-SDU2	490
parallel data output	259
parallel I/O connector	32
Parallel Interface Sensor Data Unit	256
parallel judgement outputs	258
password	223
PC Tool	27, 486
PNP	43, 49
Polarizing Filter	
using	65
Position compensation	183
position compensation items	74
Position X	96, 106, 114, 121
Position Y	96, 106, 114, 121
Positive	245, 270
power supply and ground terminal block	32
power supply switch	
Touch Finder	31
preventing mutual interference of	
multiple Sensors	67

<b>R</b>	
R average	138
Record separator	212
reference color	
re-registering	246
RESET	45, 47
restarting	
Sensor and Touch Finder	229
Rotation	77
RS-232C connections	392
RS-232C connector	32
RS-232C no-protocol commands	395
RS-232C no-protocol communications	393
RUN	45, 47
Run Mode	23
<b>S</b>	
saturation	137
saved images	
displaying	201
saving data	178, 218
saving image data	227
scene data	
saving	218
scene group data	
saving	218
scenes	
changing	190
changing names	191
copying	191
deleting	191
switching	246
SD card	
available space	222
formatting	222
information	222
operations	221
slot	31
SD card formatting	222
search position compensation	78
searching	
inspection items	95, 105, 113
selected color images	143, 149
sensitive search	113
Sensor connector	32
Sensor data	
saving all Sensor data	218
Sensor Data Unit Cable	44, 46, 489
Sensor Data Units	32, 483
Sensor information	230
sensor monitor	183
Sensor selection	225
Sensor system data	
saving	218
Sensors	
renaming	230
single-function models	472
specifications	472
standard models	472
switching	58
Sensors with Built-in Lighting	29
Sensors with C-mounts	30
Set color	124, 142, 148
setting data communications specifications	
Parallel Sensor Data Unit	262
setting the data to output automatically	
after measurements	395
EtherNet/IP	295
no-protocol (RS-232C)	395
no-protocol (TCP)	351
PLC Link	329
setting up communications specifications	
EtherNet/IP	289
no-protocol (RS-232C)	394
no-protocol (TCP)	351
PLC Link	327
setting up Ethernet	53
setting up no-protocol communications	394
Setup Mode	23
Shape Search II	105
shape search position compensation	77
SHTOUT	45, 47
Shutter speed	62
slider	32
sorting method	107
source image	70
startup display	183
startup mode	192
startup scene	192
startup setting	192
Statistical data	182
statistical data	
logging	216
STGOUT	45, 47
straps	40
Strong Smoothing	69
subnet mask	55
Sub-pixel	97
Summary of Requirements	
to Manufactures	498
Summary of Requirements to User	500
Switch Sensor	58
Switching Hub	27
system configuration	26
<b>T</b>	
takt time	172
TCP no-protocol communications	350
teaching errors	
labeling	154
sensitive search	119
test measurements	
continuous test	170
performing	170
threshold	
average	176
maximum	176
minimum	176
time	
Touch Finder	229
Total label area	148
Touch Finder	479

information	230
model with AC/DC/battery	
power supply	479
model with DC power supply	479
time settings	229
Touch Finder data	
saving	218
trend monitor	
Auto display	184
Display range	184
Number of data	185
TRIG	45
TRIG0	47
trigger delay	66, 67
two Touch Finders connected	
at the same time	225
two-edge midpoint compensation	83
two-edge position compensation	81
<hr/>	
U	
updating	
software version	491
<hr/>	
V	
versions	230
<hr/>	
W	
Weak Smoothing	69
white balance	65
width amount	128
wiring	42
Sensor	42
Sensor Data Units	44
Touch Finder	50
<hr/>	
Z	
zooming	200



# Revision History

A manual revision code appears as a suffix to the catalog number at the bottom of the front and back covers of this manual.

Cat. No. Z326-E1-01A

↑  
Revision code

Revision code	Date	Revised contents
01	July 2012	Original production
01A	October 2012	Minor corrections



**OMRON INDUSTRIAL AUTOMATION • THE AMERICAS HEADQUARTERS**

Schaumburg, IL USA • 847.843.7900 • 800.556.6766 • [www.omron247.com](http://www.omron247.com)

---

**OMRON CANADA, INC. • HEAD OFFICE**

Toronto, ON, Canada • 416.286.6465 • 866.986.6766 • [www.omron247.com](http://www.omron247.com)

**OMRON ELECTRONICS DE MEXICO • HEAD OFFICE**

México DF • 52.55.59.01.43.00 • 001.800.556.6766 • [mela@omron.com](mailto:mela@omron.com)

**OMRON ELECTRONICS DE MEXICO • SALES OFFICE**

Apodaca, N.L. • 52.81.11.56.99.20 • 001.800.556.6766 • [mela@omron.com](mailto:mela@omron.com)

**OMRON ELETRÔNICA DO BRASIL LTDA • HEAD OFFICE**

São Paulo, SP, Brasil • 55.11.2101.6300 • [www.omron.com.br](http://www.omron.com.br)

**OMRON ARGENTINA • SALES OFFICE**

Cono Sur • 54.11.4783.5300

**OMRON CHILE • SALES OFFICE**

Santiago • 56.9.9917.3920

**OTHER OMRON LATIN AMERICA SALES**

54.11.4783.5300

---

**OMRON EUROPE B.V.** • Wegalaan 67-69, NL-2132 JD, Hoofddorp, The Netherlands. • Tel: +31 (0) 23 568 13 00

Fax: +31 (0) 23 568 13 88 • [www.industrial.omron.eu](http://www.industrial.omron.eu)