

RFID System

V680S Series

User's Manual

Reader/Writer

V680S-HMD64-ETN

V680S-HMD66-ETN

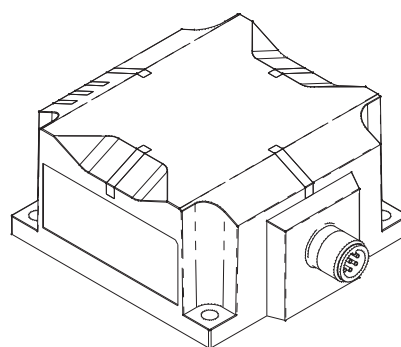
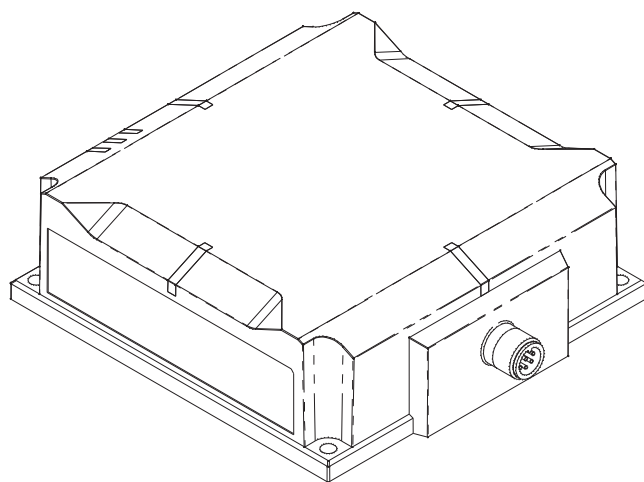

Introduction

Thank you for purchasing a V680S-series RFID System. This manual describes the functions, performance, and application methods needed for optimum use of the V680S-series RFID System.

Please observe the following items when using the V680S-series RFID System.

- Allow the V680S-series RFID System to be installed and operated only by qualified specialists with a sufficient knowledge of electrical systems.
- Read and understand this manual before attempting to use the RFID System and use the RFID System correctly.
- Keep this manual in a safe and accessible location so that it is available for reference when required.

Introduction	READ AND UNDERSTAND THIS DOCUMENT (Always Read This Information)	Introduction
Section 1	Product Overview	Section 1
Section 2	Names and Functions of Components	Section 2
Section 3	Installation and Connections	Section 3
Section 4	Preparations for Communications	Section 4
Section 5	Host Communications Specifications	Section 5
Section 6	Browser Interface	Section 6
Section 7	Troubleshooting	Section 7
Section 8	Appendices	Section 8

RFID System

V680S-HMD64-ETN
V680S-HMD66-ETN

Reader/Writer
Reader/Writer

User's Manual

READ AND UNDERSTAND THIS DOCUMENT

Please read and understand this document before using the products. Please consult your OMRON representative if you have any questions or comments.

WARRANTY

OMRON's exclusive warranty is that the products are free from defects in materials and workmanship for a period of one year (or other period if specified) from date of sale by OMRON.

OMRON MAKES NO WARRANTY OR REPRESENTATION, EXPRESS OR IMPLIED, REGARDING NON-INFRINGEMENT, MERCHANTABILITY, OR FITNESS FOR PARTICULAR PURPOSE OF THE PRODUCTS. ANY BUYER OR USER ACKNOWLEDGES THAT THE BUYER OR USER ALONE HAS DETERMINED THAT THE PRODUCTS WILL SUITABLY MEET THE REQUIREMENTS OF THEIR INTENDED USE. OMRON DISCLAIMS ALL OTHER WARRANTIES, EXPRESS OR IMPLIED.

LIMITATIONS OF LIABILITY

OMRON SHALL NOT BE RESPONSIBLE FOR SPECIAL, INDIRECT, OR CONSEQUENTIAL DAMAGES, LOSS OF PROFITS OR COMMERCIAL LOSS IN ANY WAY CONNECTED WITH THE PRODUCTS, WHETHER SUCH CLAIM IS BASED ON CONTRACT, WARRANTY, NEGLIGENCE, OR STRICT LIABILITY.

In no event shall responsibility of OMRON for any act exceed the individual price of the product on which liability is asserted.

IN NO EVENT SHALL OMRON BE RESPONSIBLE FOR WARRANTY, REPAIR, OR OTHER CLAIMS REGARDING THE PRODUCTS UNLESS OMRON'S ANALYSIS CONFIRMS THAT THE PRODUCTS WERE PROPERLY HANDLED, STORED, INSTALLED, AND MAINTAINED AND NOT SUBJECT TO CONTAMINATION, ABUSE, MISUSE, OR INAPPROPRIATE MODIFICATION OR REPAIR.

SUITABILITY FOR USE

THE PRODUCTS CONTAINED IN THIS DOCUMENT ARE NOT SAFETY RATED. THEY ARE NOT DESIGNED OR RATED FOR ENSURING SAFETY OF PERSONS, AND SHOULD NOT BE RELIED UPON AS A SAFETY COMPONENT OR PROTECTIVE DEVICE FOR SUCH PURPOSES. Please refer to separate catalogs for OMRON's safety rated products.

OMRON shall not be responsible for conformity with any standards, codes, or regulations that apply to the combination of products in the customer's application or use of the product.

At the customer's request, OMRON will provide applicable third party certification documents identifying ratings and limitations of use that apply to the products. This information by itself is not sufficient for a complete determination of the suitability of the products in combination with the end product, machine, system, or other application or use.

The following are some examples of applications for which particular attention must be given. This is not intended to be an exhaustive list of all possible uses of the products, nor is it intended to imply that the uses listed may be suitable for the products:

- Outdoor use, uses involving potential chemical contamination or electrical interference, or conditions or uses not described in this document.
- Nuclear energy control systems, combustion systems, railroad systems, aviation systems, medical equipment, amusement machines, vehicles, safety equipment, and installations subject to separate industry or government regulations.
- Systems, machines, and equipment that could present a risk to life or property.

Please know and observe all prohibitions of use applicable to the products.

NEVER USE THE PRODUCTS FOR AN APPLICATION INVOLVING SERIOUS RISK TO LIFE OR PROPERTY WITHOUT ENSURING THAT THE SYSTEM AS A WHOLE HAS BEEN DESIGNED TO ADDRESS THE RISKS, AND THAT THE OMRON PRODUCT IS PROPERLY RATED AND INSTALLED FOR THE INTENDED USE WITHIN THE OVERALL EQUIPMENT OR SYSTEM.

PERFORMANCE DATA

Performance data given in this document is provided as a guide for the user in determining suitability and does not constitute a warranty. It may represent the result of OMRON's test conditions, and the users must correlate it to actual application requirements. Actual performance is subject to the OMRON Warranty and Limitations of Liability.

CHANGE IN SPECIFICATIONS

Product specifications and accessories may be changed at any time based on improvements and other reasons.

It is our practice to change model numbers when published ratings or features are changed, or when significant construction changes are made. However, some specifications of the product may be changed without any notice. When in doubt, special model numbers may be assigned to fix or establish key specifications for your application on your request. Please consult with your OMRON representative at any time to confirm actual specifications of purchased products.

DIMENSIONS AND WEIGHTS

Dimensions and weights are nominal and are not to be used for manufacturing purposes, even when tolerances are shown.

ERRORS AND OMISSIONS

The information in this document has been carefully checked and is believed to be accurate; however, no responsibility is assumed for clerical, typographical, or proofreading errors, or omissions.

PROGRAMMABLE PRODUCTS

OMRON shall not be responsible for the user's programming of a programmable product, or any consequence thereof.

COPYRIGHT AND COPY PERMISSION

This document shall not be copied for sales or promotions without permission. This document is protected by copyright and is intended solely for use in conjunction with the product. Please notify us before copying or reproducing this document in any manner, for any other purpose. If copying or transmitting this document to another, please copy or transmit it in its entirety.

Safety Precautions

- Signal Words Used in This Manual

The following notation and alert symbols are used in this User's Manual to provide precautions required to ensure safe usage of the V680S-HMD64-ETN/-HMD66-ETN Reader/Writers and V680-series RF Tags. The precautions provided here contain important safety information. Be sure to observe these precautions.

The following signal words are used in this manual.



Indicates a potentially hazardous situation which, if not avoided, will result in minor or moderate injury, or may result in serious injury or death. Additionally there may be significant property damage.

- Meanings of Alert Symbols



Prohibition
Indicates general prohibitions for which there is no specific symbol.

- Warning



The Product is not designed or rated for ensuring the safety of persons.
Do not use it for such purposes.



Precautions for Safe Use

Observe the following precautions to ensure safe use of the Product.

1. Installation and Storage Environment

- Do not install the Product near any equipment that generates a large amount of heat (such as heaters, transformers, and large-capacity resistors).
- If multiple Reader/Writers are installed near each other, communications performance may decrease due to mutual interference. Refer to *Mutual Interference of Reader/Writers (for Reference Only)* in *RF Tag Installation Precautions* in *Section 8 Appendices* and check to make sure there is no mutual interference between Reader/Writers.

2. Installation and Removal

- Never use an AC power supply. Doing so may result in rupture.
- Wire the Product correctly. Incorrect wiring may result in rupture or burning.
- Please use a device supporting STP cables for the host device (such as an Ethernet switch or PLC) which is connected the specified Cables (V680S-A41 □M/-A42 □M). Ground the host device to a ground resistance of 100 Ω or less.
- Use one of the specified Cables (V680S-A40 □M/-A41 □M/-A42 □M). Using any other cable may cause malfunctions or failure.

3. Application Methods

- Do not bend the Cable to a bending radius of 40 mm or less. Doing so may break the wires.
- If an error is detected in the Product, immediately stop operation and turn OFF the power supply. Consult with an OMRON representative.

4. Cleaning

- Do not clean the Product with paint thinner, benzene, acetone, or kerosene.

5. Disposal

- Dispose of the Product as industrial waste.

Precautions for Correct Use

Always observe the following precautions to prevent operation failures, malfunctions, and adverse effects on performance and equipment.

1. Installation and Storage Environment

Do not use or store the Product in the following locations.

- Locations subject to combustible gases, explosive gases, corrosive gases, dust, dirt, metal powder, or salt
- Locations where the specified ambient temperature range or ambient humidity range is exceeded
- Locations subject to extreme temperature changes that may result in condensation
- Locations subject to direct vibration or shock outside the specified ranges

2. Installation

- This Product uses a frequency band of 13.56 MHz to communicate with RF Tags. Some transceivers, motors, inverters, switch-mode power supplies, and other devices generate electrical noise that will affect these communications. If any of these devices are located in the vicinity of the Product, they may affect communications with RF Tags, and may possibly damage the RF Tags. Prior to using the Product in the vicinity of any of these devices, perform a test to determine whether the Product can be used under the resulting influence.
- Connect the control signal to the positive and negative sides of the power supply. The control signal is used to change the operation mode of the Reader/Writer.



CHECK!

Refer to *Connecting the V680S-A41 □M Cable to the Host Device* in *Section 3 Installation and Connections* for the connector method.



p.47

- Do not exceed the rated voltage range. Doing so may result in Product destruction or burning.
- Tighten the mounting screws to a torque of 1.2 N·m.
- Tighten the Cable connector to a torque of 0.39 to 0.49 N·m.

3. Application Methods

- Do not drop the Product.
- Do not pull on the Cables with excessive force.
- Do not attempt to disassemble, repair, or modify the Product.

4. Maintenance

- Perform inspections both daily and periodically.



CHECK!

Refer to *Maintenance and Inspection* in *Section 7 Troubleshooting* for the items to inspect.



p.130

5. Others

- When using V680S-HMD66-ETN, Install the ferrite core of the attachment to the exclusive cable as modev V680S-A41 □M, or V680A-A42 □M.

Meanings of Symbols



Indicates particularly important points related to a function, including precautions and application advice.



Indicates page numbers containing relevant information.



Indicates reference to helpful information and explanations for difficult terminology.

Table of Contents

Introduction	1
READ AND UNDERSTAND THIS DOCUMENT	2
Safety Precautions	3
Precautions for Safe Use	4
Precautions for Correct Use	5
Meanings of Symbols	6
Table of Contents	7
<hr/>	
Section 1 Product Overview	9
Features	10
System Configuration	11
Application Flowchart	12
<hr/>	
Section 2 Names and Functions of Components	15
Component Names	16
Functions	20
<hr/>	
Section 3 Installation and Connections	35
Installation	36
Connections and Wiring	45
<hr/>	
Section 4 Preparations for Communications	51
Starting the Reader/Writer	52
Setting Communications Conditions	53
Communications Test	54
<hr/>	
Section 5 Host Communications Specifications	55
Modbus Communications Protocol	56
Message Details	68
Initializing All Settings	105

Section 6 Browser Interface	107
Browser Operation Window	108
Operation Interface	109
Section 7 Troubleshooting	123
Error Descriptions	124
Errors and Indicator Status	125
Errors and Countermeasures	127
Maintenance and Inspection	130
Troubleshooting Flowcharts	131
Safe Mode	136
Section 8 Appendices	137
Product Specifications	138
Data Characteristics	154
Reader/Writer Installation Precautions	164
RF Tag Installation Precautions	166
RF Tag Memory Capacities and Memory Types	186
RF Tag Memory Map	187
Chemical Resistance of the Reader/Writers and RF Tags	188
Degree of Protection	191
Revision History	194

Section 1

Product Overview

▣ Features	10
▣ System Configuration	11
▣ Application Flowchart	12

Features

The integrated V680S-series Reader/Writers (V680S-HMD64-ETN/-HMD66-ETN- perform communications with RF Tags according to queries from a host device or according to queries that are registered in advance.

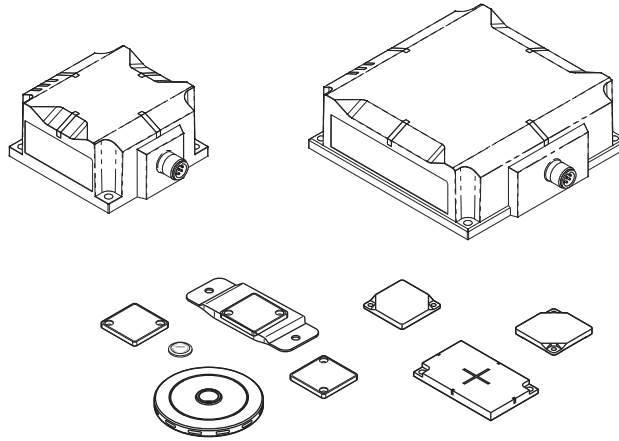

■ Integrated Structure

The controller, amplifier, and antenna are integrated into the Reader/Writer for a simple structure.

■ Simple Installation

The Reader/Writer is automatically set to the best parameters according to the RF Tags to achieve stable communications with more consistent communications and no omissions of RF Tags in the communications area.

■ Simple Connection

The highly generic Ethernet is used to connect to the host device to enable easy connection with Ethernet cable without any restrictions from the host PLC manufacturer. An Ethernet switch can be used to easily connect more than one RFID System.

■ Easy Operation

A Web server is provided so that you can easily perform setup and status monitoring by connecting to a computer, without the need for any special software.

System Configuration

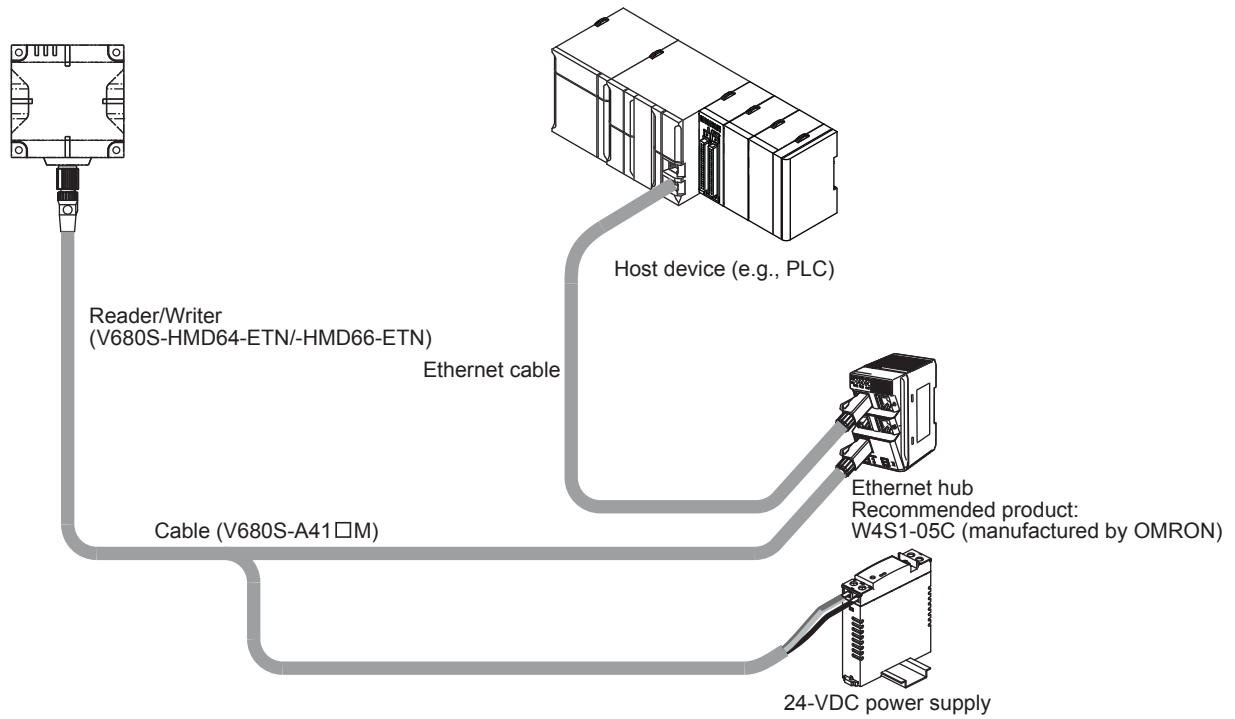

Please use a device supporting STP cables for the host device (such as an Ethernet switch or PLC) which is connected the specified Cables (V680S-A41 □M/-A42 □M). Ground the host device to a ground resistance of 100 Ω or less.

CHECK!



Use one of the specified Cables (V680S-A40 □M/-A41 □M/-A42 □M). Maximum extension length of the cable is 60m. It is not possible to connect the extension cable and extension cable (V680S-A40 □M).

CHECK!

Application Flowchart

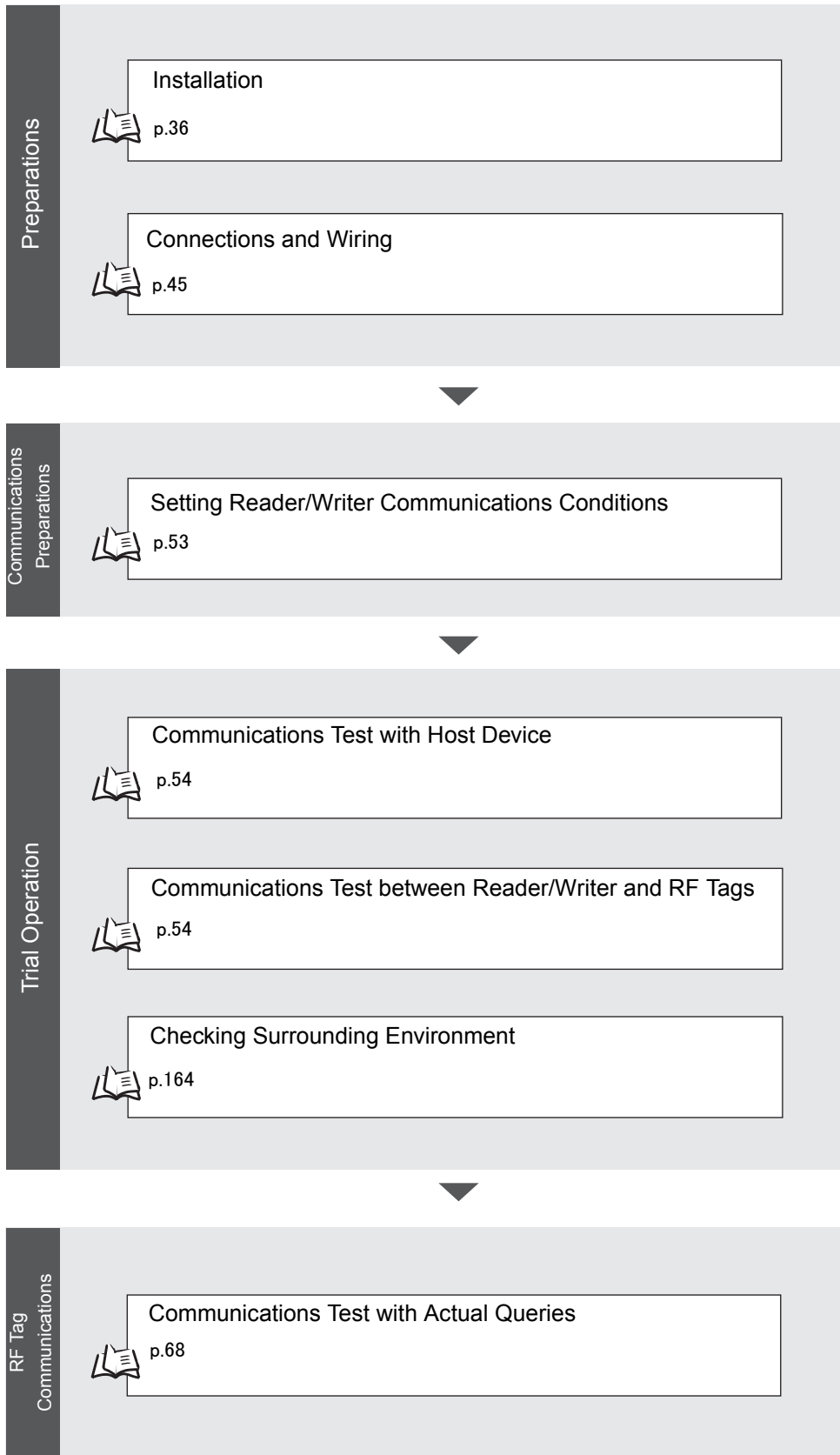



If you Encounter a Problem...

Troubleshooting



p.65 Exception Code Table



p.16 Exception Code Table



p.131 Troubleshooting Flowcharts

MEMO

Section 2

Names and Functions of Components

☒ Component Names	16
☒ Functions	20

Component Names

Reader/Writer

V680S-HMD64-ETN

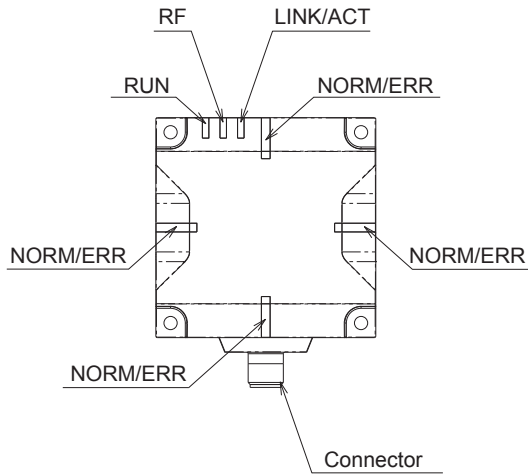

V680S-HMD66-ETN

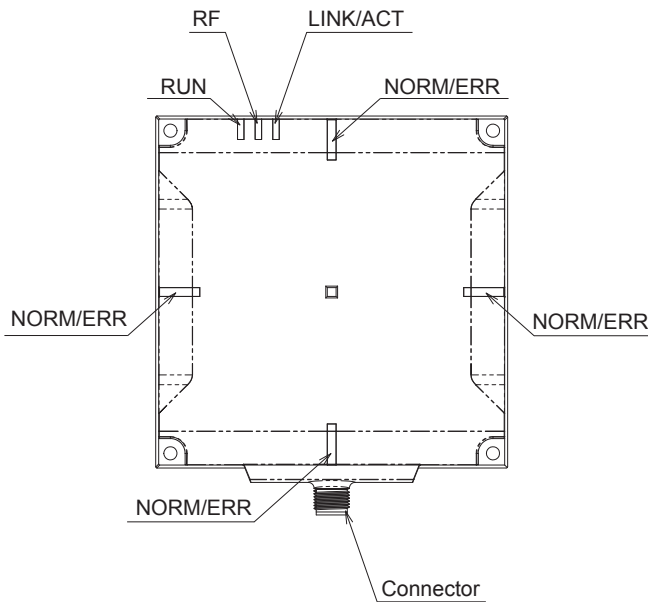

■ Operation Indicators

■ RUN

Status	Meaning
green	Lighting while the Reader/Writer is operating normally.
Flashing green	Flash while the Reader/Writer is operating in Safe mode.
Not lit	Turn off when power is not supplied.

■ RF

Status	Meaning
yellow	Lighting during communication for RF Tag.
Not lit	Turn off when not in communication with no error.

■ NORM/ERR

The NORM/ERR indicator shows the result of communications with an RF Tag.

Status	Meaning
green	Lighting when the communications finish with no error.
red	Lighting once when an error occurs during communications with the host device, or during communications with an RF Tag. Lighting when unrecoverable error occurs.
Flashing red	Flash when recoverable error occurs. (Configuration memory error, or Control signal wiring mistake, etc.)
Not lit	Turn off when the standby state.

■ LINK/ACT

Status	Meaning
green	Lighting during linking normally.
Flashing green	Flash during detects a carrier.
Not lit	Turn off when the ethernet cable is not connected.



Refer to *Errors and Indicator Status* in Section 7 *Troubleshooting* for information of Error content of the operation indicator

CHECK!



p.125

■ Connector

The connector is used to connect the exclusive cable as model V680S-40 □M, V680S-A41 □M, or V680S-A42 □M.

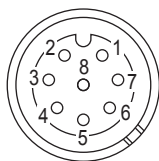

Pin No.	Name	Description	V680S-A41 wire color	V680S-A42 wire color	I/O
1	24P	+24V	Brown	Brown	---
2	FG	Frame ground	---	(Drain wire)	---
3	CONT	Control signal (Controls entering Safe Mode.)	Violet	Violet	Input
4	TD-	Ethernet send - signal	---	Orange	Output
5	RD+	Ethernet receive + signal	---	Green with white strip	Input
6	TD+	Ethernet send + signal	---	Orange with white strip	Output
7	24N	0V	Blue	Blue	---
8	RD-	Ethernet receive - signal	---	green	Input

Cables

■ V680S-A40 □M

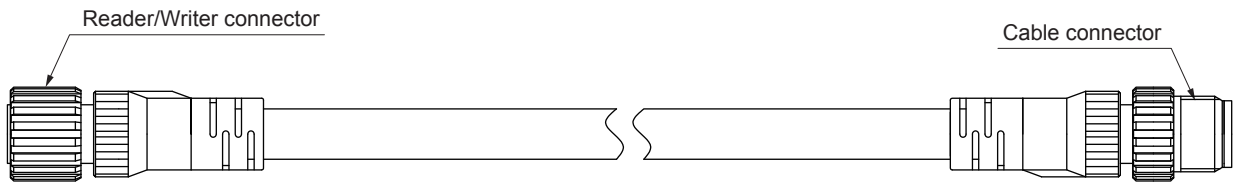

■ Reader/Writer connector

This connector connects to the connector on the Reader/Writer.

■ Cable Connector

This connector connects to the Reader/Writer connector on the V680S-A41□M / -A42□M Cable.

■ V680S-A41 □M

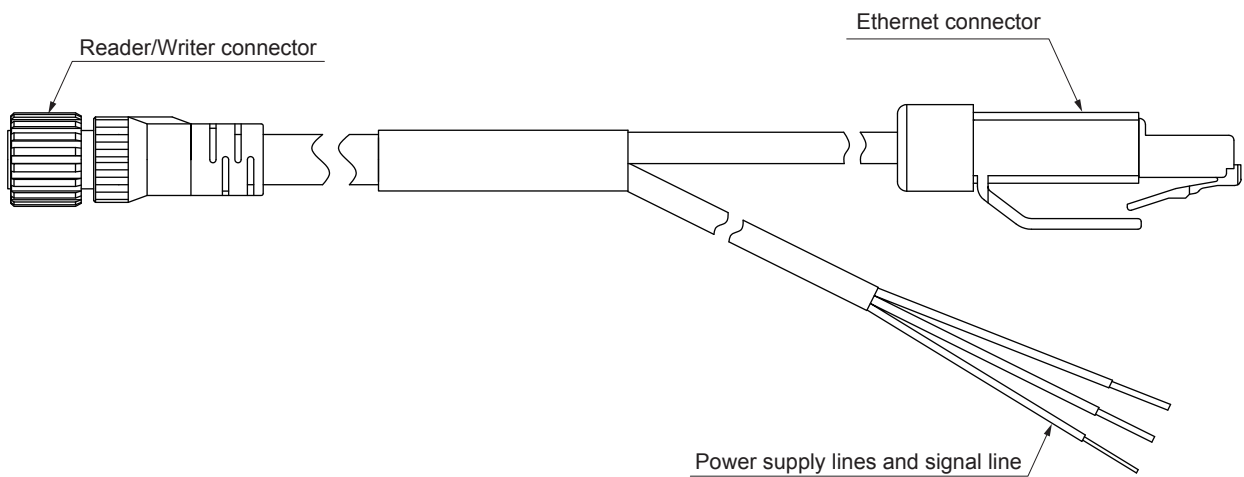

■ Reader/Writer connector

This connector connects to the connector on the Reader/Writer or to the V680S-A40 □M Extension Cable.

■ Ethernet Connector

This connector connects to the Ethernet switch.

■ Power Supply and Signal Lines

These lines supply power and the control signal to the Reader/Writer.

■ V680S-A42 □M

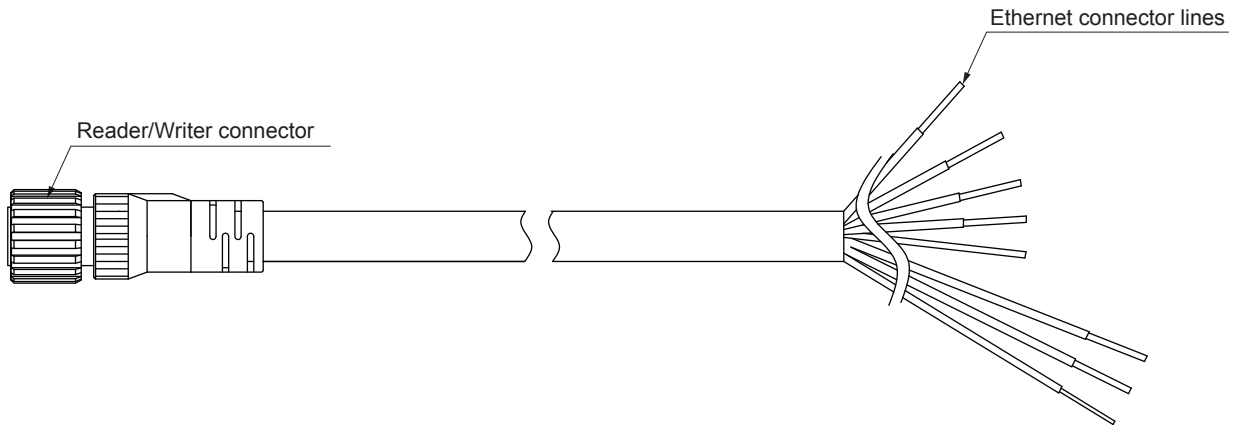

■ **Reader/Writer connector**

This connector connects to the connector on the Reader/Writer or to the V680S-A40 □M Extension Cable.

■ **Ethernet Connector Lines**

These lines are connected to an Ethernet connector to supply power and the control signal to the Reader/Writer. The Reader/Writer supports for Auto-MDIX, can communicate by both straight and cross ethernet lines.

RF Tag

■ V680-D1KP54T

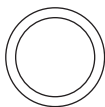

■ V680-D1KP66T/-D1KP66MT

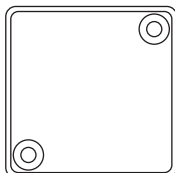

■ V680-D1KP66T-SP

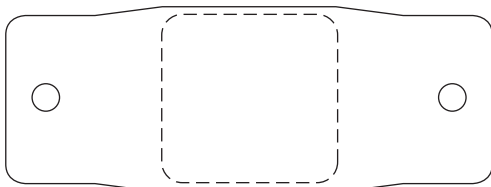

■ V680-D1KP58HTN

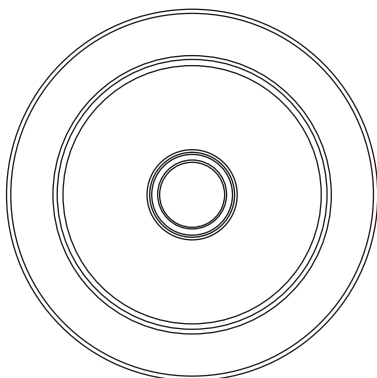

■ V680-D8KF67/-D8KF67M

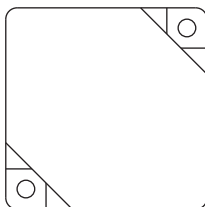

■ V680-D8KF68A

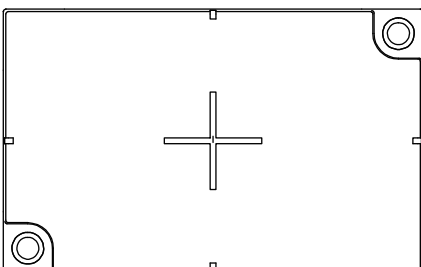

Functions

Operation Mode

The Reader/Writer has two operation modes: Run Mode and Safe Mode.

You can use the control signal to the Reader/Writer connector to change between these modes.

■ Run Mode

When you connect the control signal to the 24-VDC side of the power supply and turn ON the power supply, the Reader/Writer will start in Run Mode.

In Run Mode, operation is performed according to queries from the host device and the results are returned to the host device as responses.

■ Safe Mode

When you connect the control signal to the 0-VDC side of the power supply and turn ON the power supply, the Reader/Writer will start in Safe Mode. The Safe Mode is used when you do not remember the IP address that is set in the Reader/Writer. In Safe Mode, the Reader/Writer will start with the following IP settings.

IP address: 192.168.1.200

Subnet mask: 255.255.255.0

RF Tag Communications

Communications Options

Communications with the RF Tag are performed according to one of the communications options that are listed in the following table.

The setting of the communications option is effective immediately after it is changed. It is saved in internal memory in the Reader/Writer even after the power supply is turned OFF.

Name	Description
Once	When the Reader/Writer receives a query, it returns a response.
Auto	When the Reader/Writer receives a query, it waits until an RF Tag is detected within the communications area, and then returns a response.
FIFO Trigger	When the Reader/Writer receives a query, it returns a response. After communicating, all further operations with that RF Tag are prohibited. The Reader/Writer communicates with only one operable RF Tag in the communications area. If an RF Tag that has been communicated with for a Once specification is within the communications area, the Reader/Writer will not communicate with it a second time.

Once

Communications with the RF Tag are performed according to queries that are sent from the host device.

When the Reader/Writer has completed communicating with the RF Tag, it sends a response to the host device and then waits for another query.

If there is no RF Tag in the communications area when the Reader/Writer receives a query from the host device, the Reader/Writer returns an RF Tag missing error (error code: 2001 hex). Use a sensor or other means to confirm the presence of an RF Tag before sending the query.

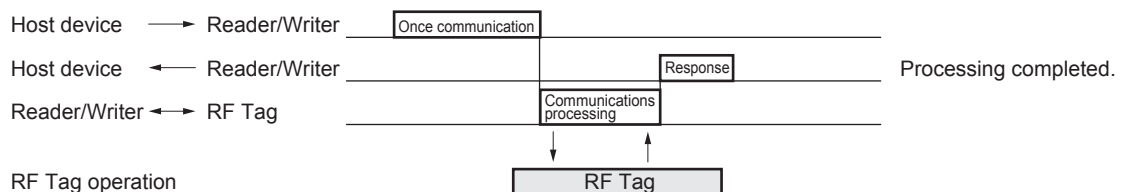
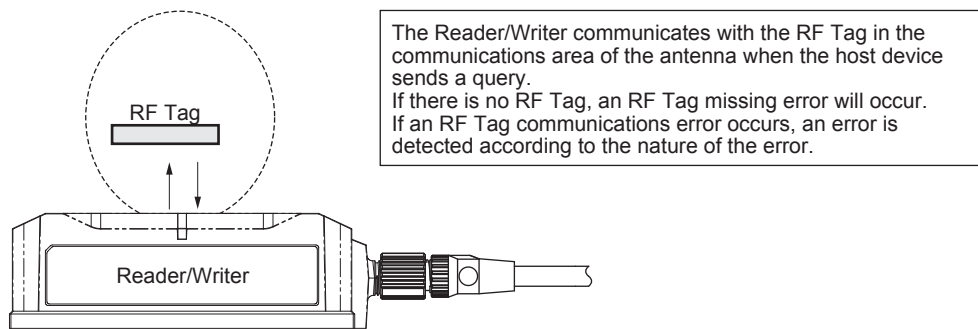

▪ **Auto**

The Reader/Writer automatically detects an RF Tag and communicates with it. After the host device sends the query, the Reader/Writer automatically detects an RF Tag that enters the communications area and communicates with it.

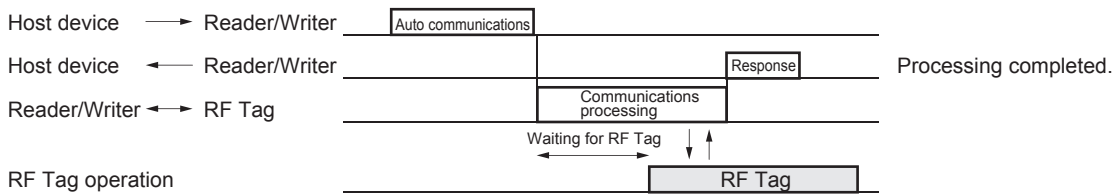
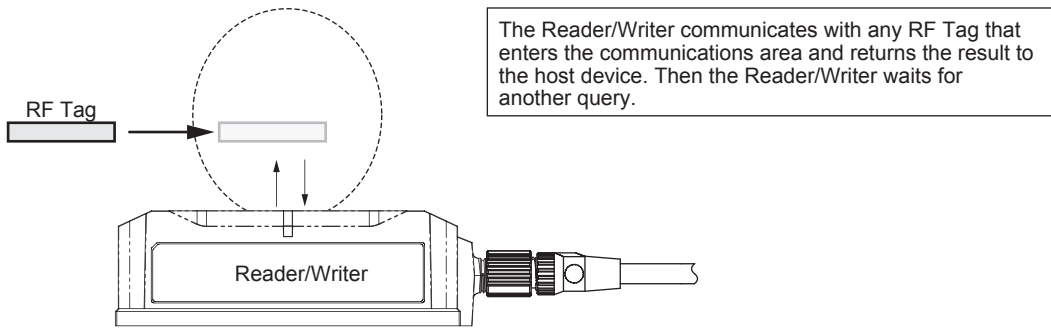

▪ **FIFO Trigger**

After communicating with an RF Tag, access to that RF Tag is prohibited. The Reader/Writer sends a response to the host device and then waits for another query.

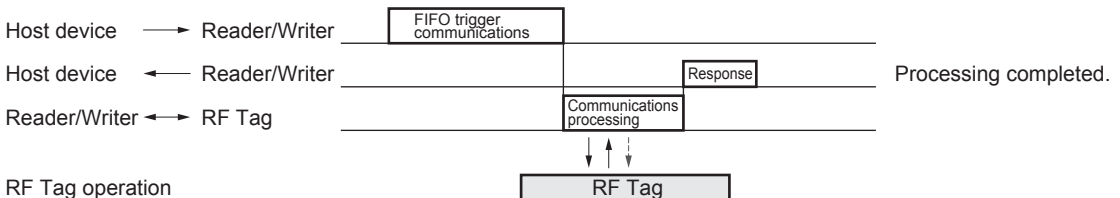
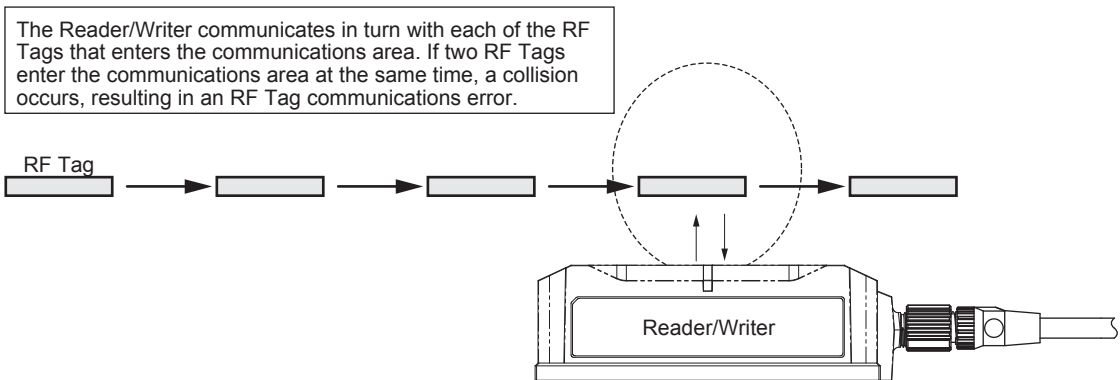

⋮ Indicates that access is prohibited.

■ Normal RF Tag Communications

Communications with the RF Tag are performed by using the queries that are listed in the following table.

Name	Description	Page
READ DATA	Reads data from an RF Tag.	p.68
WRITE DATA	Writes data to the memory of the RF Tag.	p.69
READ ID	Reads the RF Tag's ID code.	p.70
DATA FILL	Writes the specified data to the specified number of words beginning from the specified start address. The specifications are made in the query.	p.72
LOCK	Locks the specified memory block in the RF Tag. It will no longer be possible to write data to the locked memory block. The lock cannot be released.	p.73
DATA COPY	Reads data from the memory of an RF Tag using one Reader/Writer (A) and writes it to the memory of the RF Tag in the communications area of another Reader/Writer (B).	p.71

■ Tag Memory Management

■ RF TAG OVERWRITE COUNT CONTROL Query

This query can be used to determine whether the RF Tag overwrite limit has been exceeded.

- With the RF TAG OVERWRITE COUNT CONTROL query with a subtraction specification, the overwrite count is subtracted from the data in the user-specified overwrite count control area to determine whether the number of overwrites has been exceeded.
- With the RF TAG OVERWRITE COUNT CONTROL query with an addition specification, the overwrite count is added to the data in the user-specified overwrite count control area to determine whether the number of overwrites has exceeded 100,000.
- The RF TAG OVERWRITE COUNT CONTROL query with an addition specification is designed for use with an RF Tag write life of 100,000. The overwrite count control area must be set so that it is all within one block.

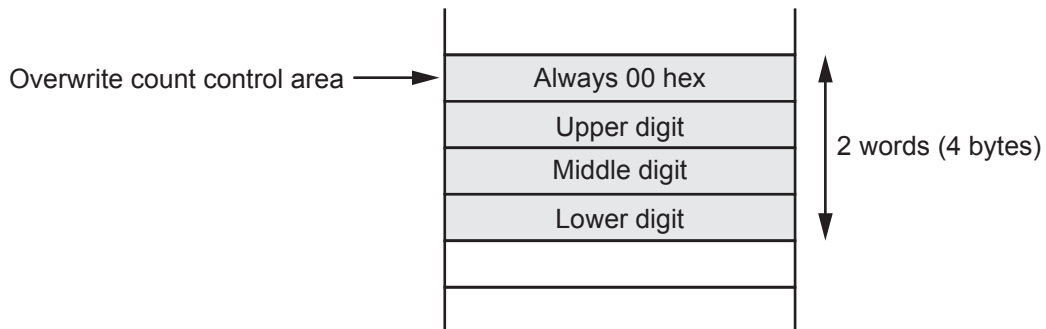

RF TAG OVERWRITE COUNT CONTROL Query with a Subtraction Specification

The overwrite count control area consists of 4 bytes from the specified start address. The decrement value is subtracted from the overwrite count and then written to this area. When the value reaches 0 (i.e., 00 hex), a warning code is returned. Therefore, to enable control of the number of overwrites, the maximum number of overwrites must be written to the overwrite count control area beforehand. You can set any number of overwrites up to 16,700,000.

You can read the overwrite count control area with a read query. If the control area data is already 0, the control area value will not be refreshed, and a warning code will be returned as a response.

When the refresh count is set to 0000 hex, the count will not be updated, and only an overwrite count check will be performed.

RF TAG OVERWRITE COUNT CONTROL Query with an Addition Specification

The overwrite count control area consists of 4 bytes from the specified start address. The increment value is added to the overwrite count and then written to this area. When the value reaches 100,000 (i.e., 0186A0 hex), a warning code is returned. You can read the overwrite count control area with a read query. If the control area data is already 100,000, the control area value will not be refreshed, and a warning code will be returned as a response. When the refresh count is set to 0000 hex, the count will not be updated, and only an overwrite count check will be performed.

Reader/Writer Controls

■ STOP Query

This query is used to cancel or abort auto communications operation and fifo communications operation.

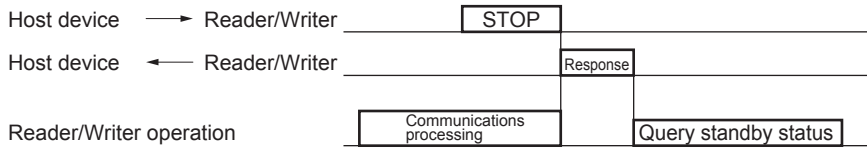

■ RESET Query

This query is used to make the Reader/Writer reset itself.

When the Reader/Writer receives this query, it returns a normal reception completed response and

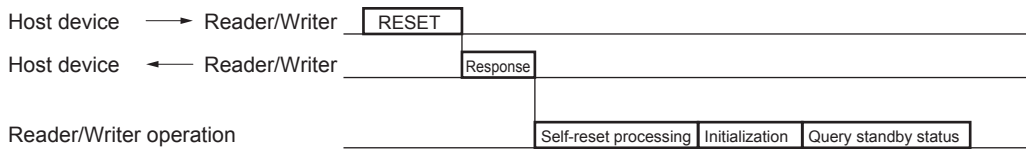

■ Maintenance

■ Noise monitor



Communication performance will be reduced when the RF tag or the Reader/Writer are influenced by ambient noise. The Reader/Writer responds the ambient noise level by using noise monitor function. The response data includes the following parameters. By checking the noise level, you can check the influence on the performance of communication with the RF tag in advance. You can also check the noise level when the trouble occurs.

Noise level (Average)	This represents the average value of the measured noise level. 00 to 99
Noise level (Maximum)	This represents the Maximum value of the measured noise level. 00 to 99
Noise level (Minimumu)	This represents the minimum value of the measured noise level. 00 to 99

The noise monitor can be performed by means of the following two.

Noise measurement query message from the host.



By sending a Noise measurement query to the Reader/Writer, you can check the noise level.

 Refer to *MEASURE NOISE* in *Section 5 Host Communications Specifications* for details on the Noise measurement query.
 p.89

Noise measurement using Web browser.

You can check the transition graph of the noise level using WEB browser.

By selecting the type of the RF tag, you are also able to visually confirm the stability of communication.

 Refer to *Noise Monitor View* in *Section 6 Browser Interface* for more information.
 p.116

If the noise level that was confirmed by WEB browser screen may affect the performance of communication, please do the following actions.

- If the other Reader/Writers are operating close to the Reader/Writer, please ensure the distance between the Reader/Writers.

 p.164, p.165

- If the equipment close to the Reader/Writer, become a source of noise transceivers, motors, inverters, and switching power supply is running, please ensure the distance until the amount of noise is sufficiently reduced. Please take action, such as enclosing the noise source by metal object.

■ GET LOG INFORMATION Query

The GET LOG INFORMATION query obtains the following log information.

Up to 8 records can be recorded in each log. The oldest records are deleted when the logs become full.

- Query log (query information and operating time for execution)
- Response log (response information and operating time for execution)
- Error log



Setting Queries

You can use setting queries to set the operating conditions of the Reader/Writer according to the application environment.

You can save the settings so that they are stored in internal memory in the Reader/Writer even after the power supply is turned OFF.

Only the settings that are made with the SET TAG COMMUNICATIONS CONDITIONS query are effective immediately after they are changed. For any changes to all other settings, you must first save them and then reset the Reader/Writer to enable using them.



Refer to *Reader/Writer Settings* in *Section 5 Host Communications Specifications* for details on the Setting query.
p.63



Refer to *Network Settings View and Communications Settings View* in *Section 6 Browser Interface* for details on the Setting query.
p.111, p.112

Setting Controls

Saving Settings

Set values are written to internal memory in the Reader/Writer.

If the Reader/Writer fails to save a setting, a memory write error (system error) will occur.

INITIALIZE SETTINGS Query

This query returns all of the set values in the Reader/Writer to their default values.

If the Reader/Writer fails to initialize the settings, a memory write error (system error) will occur.

GET DEVICE INFORMATION Query

This query is used to get the parameters that are listed in the following table from the Reader/Writer.

Model number	Model number information
Firmware versions	The firmware versions in the Reader/Writer
MAC address	MAC address
Reader/Writer operating status	Query standby status, communicating with RF Tag, or performing other processing
Operating time	The operating time (ms) from when the Reader/Writer started FFFF FFFF hex ms max.

■ SET TAG COMMUNICATIONS CONDITIONS Query

This query sets parameters that are related to the operation of communications with RF Tags. Any changes to the settings that are made with this query are effective immediately. (There is no need to reset the Reader/Writer to save the settings.)

■ RF Tag Communications Speed Setting

You can set the speed for communications between the Reader/Writer and RF Tags.

High speed (default)	This setting reduces the communications time by reading more than one block at the same time with an air interface. However, if errors are detected during communications due to ambient noise or other factors, processing is redone from the beginning, which can actually increase the communications time.
Normal speed	This setting provides more stable communications quality by reading one block at a time, in the same way as for the earlier V680. Although the normal communications time is longer, processing can be continued during communications if errors are detected due to ambient noise or other factors, which can actually reduce the communications time.

■ Write Verification

You can set whether to verify write processing.

Enabled (default)	After processing a write operation, the memory area that was written in the RF Tag is read and verified to confirm that the write operation was performed normally.
Disabled	Write processing is not verified.

■ Setting Host Device Communications Conditions

You can set parameters for communications between the Reader/Writer and host device. If you change any of these settings, you must first save them and then reset the Reader/Writer to enable using them.

■ Fixed IP Address Setting

Default setting: 192.168.1.200

■ Subnet Mask Setting

Default setting: 255.255.255.0

■ Gateway Address Setting

Default setting: 192.168.1.254

■ Setting the Web Password

You can set a password for logging in from a Web interface. The password can be up to 15 ASCII characters. No password is set by default.

If a Web password is set, a dialog box requesting entry of the password will be displayed when the initial Web server interface is displayed. If the correct password is entered, a normal Web interface can be used.

■ Setting Reader/Writer Operation

You can set parameters that control Reader/Writer operation. If you change any of these settings, you must first save them and then reset the Reader/Writer to enable using them.

Error Logs



The Reader/Writer manages errors that occur during operation in logs. The error logs are saved until the power supply to the Reader/Writer is turned OFF. You can read the error logs by sending queries from the host device or by using a browser.

The following logs are saved.

Category	Description
System error log	This log contains up to eight fatal errors that were detected by the Reader/Writer. They are given in chronological order. If more than eight system errors occur, the oldest records are deleted in order.
Communications error log	This log contains query information in chronological order for queries for which the Reader/Writer returned an error response (error codes other than 0000 hex). If more than eight system errors occur, the oldest records are deleted in order.
Recent error query log	The Reader/Writer always records all of the frame data for one query for which the Reader/Writer returned an error response.

System Error Log

Each record in the system error log consists of 16 bytes in the format that is shown in the following table. Up to eight records are recorded. To read the system error log, either send a GET SYSTEM ERROR LOG query or read it from a browser.

 Refer to *GET SYSTEM ERROR LOG* in *Section 5 Host Communications Specifications* for details on the GET SYSTEM ERROR LOG query.
CHECK!  p.99



Bytes 1 to 4	Bytes 5 to 8	Bytes 9 to 12	Bytes 13 to 16
Operating time	Error code	Attached information 1	Attached information 2
4 bytes	4 bytes	4 bytes	4 bytes

Operating Time

This is the operating time of the Reader/Writer when the error occurred.

Error Code

This code identifies the nature of the error.

 Refer to *Error Codes* in *Section 5 Host Communications Specifications* for the meanings of the error codes.
CHECK!  p.66

Attached Information 1

The Attached information 1, representing the erroneous classification settings.

00000001 hex: Network settings

00000002 hex: RF Tag communication settings

Attached Information 2

This field is always 00000000 hex.

■ Communications Error Log

Each record in the communications error log consists of 24 bytes in the format that is shown in the following table. Up to eight records are recorded. To read the communication error log, either send a GET COMMUNICATIONS ERROR LOG query or read it from a browser.



Refer to *GET COMMUNICATIONS ERROR LOG* in *Section 5 Host Communications Specifications* for details on the GET COMMUNICATIONS ERROR LOG query.

CHECK!  p.97

Bytes 1 to 4	Bytes 5 to 8	Bytes 9 to 10	Bytes 11 to 12
Operating time when error occurred	IP address of query source	Transaction identifier	Reserved.
4 bytes	4 bytes	2 bytes	2 bytes

Byte 13	Byte 14	Bytes 15 and 16	Byte 17	Bytes 18 to 20	Bytes 21 and 22	Bytes 23 and 24
Function code	Reserved.	Register address	Exception code	Reserved.	Error code	Error source device information
1 byte	1 byte	2 bytes	1 byte	3 bytes	2 bytes	2 bytes

■ Operating Time When Error Occurred

This is the operating time when the Reader/Writer returned the error response to the host device after the error occurred.

■ IP Address of Query Source

This is the IP address of the host device that sent the query.

■ Transaction Identifier

This is the transaction identifier of the query that was received by the Reader/Writer.

■ Function Code

This is the function code in the query that was received by the Reader/Writer.

■ Register Address

This is the register address in the query that was received by the Reader/Writer.

■ Exception Code

This is the exception code in the response that was returned by the Reader/Writer.

■ Error Code

This code identifies the nature of the error.



Refer to *Error Codes* in *Section 5 Host Communications Specifications* for the meanings of the error codes.

CHECK!  p.66

- **Error Source Device Information**

If the error occurs in the Reader/Writer after receiving a query from the host device, the error source device information is set to 0000 hex. If the COPY DATA query is sent and the error occurred at the copy destination Reader/Writer, the error source device information is set to 0001 hex.

- **Reserved**

Reserved fields are always 00 hex.

Recent Error Query Log

The record in the recent error query log consists of 250 bytes in the format that is shown in the following table. Only one record is ever recorded in the recent error query log. To read the recent error query log, either send a GET RECENT ERROR QUERY INFORMATION query or read it from a browser.



Refer to *GET RECENT ERROR QUERY INFORMATION* in *Section 5 Host Communications Specifications* for details on the GET RECENT ERROR QUERY INFORMATION query.

CHECK!  p.95

Bytes 1 to 4	Bytes 5 to 8	Bytes 9 to 10	Bytes 11 to 12
Operating time when error occurred	IP address of query source	Error code	Error source device information
4 bytes	4 bytes	2 bytes	2 bytes

Byte 13	Byte 14	Bytes 15 to 252
Exception code	Communications query information size	Communications query information
1 byte	1 byte	236 bytes

Range specified with the communications query information size.

Operating Time When Error Occurred

This is the operating time when the Reader/Writer returned the error response to the host device after the error occurred.

IP Address of Query Source

This is the IP address of the host device that sent the query.

Error Code

This code identifies the nature of the error.



Refer to *Error Codes* in *Section 5 Host Communications Specifications* for the meanings of the error codes.

CHECK!  p.66

Error Source Device Information

If the error occurs in the Reader/Writer after receiving a query from the host device, the error source device information is set to 0000 hex. If the COPY DATA query is sent and the error occurred at the copy destination Reader/Writer, the error source device information is set to 0001 hex.

Exception Code

This is the exception code in the response that was returned by the Reader/Writer.

Communications Query Information Size

This size gives the valid byte size of the communications query information field.

Communications Query Information

This is all of the frame data for the query that was received by the Reader/Writer.

Web Server

The following functions are provided in the Web server interface.

■ Status Monitoring, Setting, and Confirmation

■ Status Monitoring

You can monitor the status of the Reader/Writer. The Reader/Writer status includes the firmware versions, MAC address, network settings, operating status, and other status information.

■ Setting

You can set any of the settable parameters from the Web server interface. This includes the network settings, RF Tag communications settings, etc.

■ Importing and Exporting Settings

You can import and export the Reader/Writer setting information. You can store or view the configuration file on a computer. You can use importing to simplify setting up more than one Reader/Writer and you can use exporting to store and restore settings information as a countermeasure for problems.

■ Convenient Functions

■ Simple Operation Test

You can send queries from the Web server interface to operate the Reader/Writer without any special software.

■ Utilities

You can display the results of noise measurements or error log information.

MEMO

Section 3

Installation and Connections

☒ Installation	36
☒ Connections and Wiring	45

Installation

Reader/Writer

■ V680S-HMD64-ETN

Install the Reader/Writer with four M4 screws. Use both spring washers and flat washers.

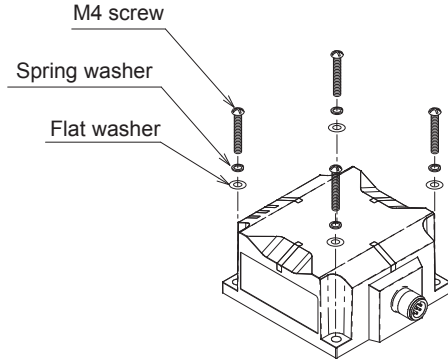

Mounting Hole Dimensions

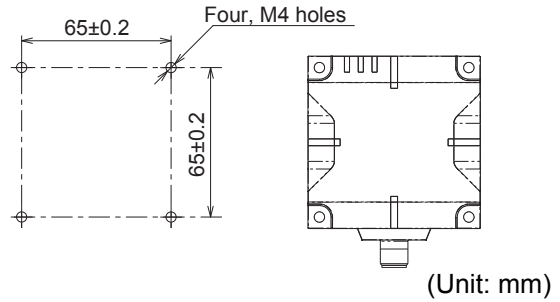

When you install the Reader/Writer, please have the bracket as shown in the figure below.

Material: Steel, SUS

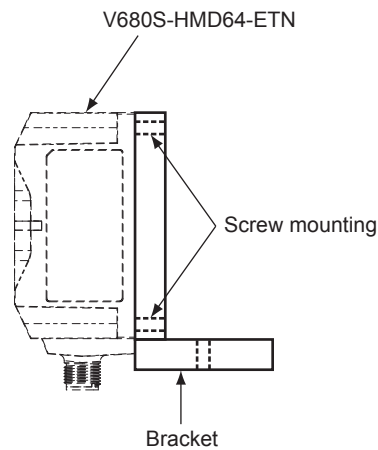
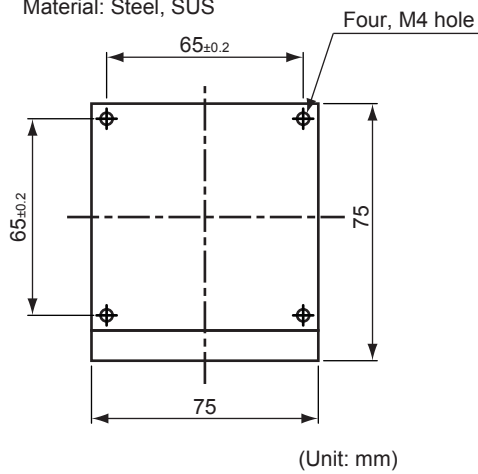

Although it is possible to use aluminum in addition to iron and copper as a mounting bracket, communication performance will change depending on the material. Please do not use resin as a mounting bracket.



The recommended tightening torque for M4 screws is 1.2 N·m.



Refer to *Reader/Writer Installation Precautions* in *Section 8 Appendices* for information of surrounding metal and Mutual Interference of Reader/Writers.

p.164

■ V680S-HMD66-ETN

Install the Reader/Writer with four M4 screws. Use both spring washers and flat washers.

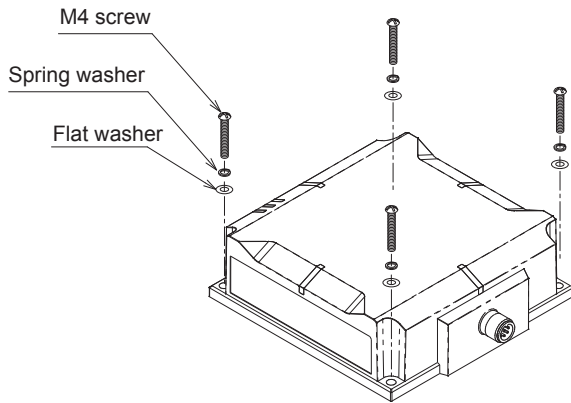

Mounting Hole Dimensions

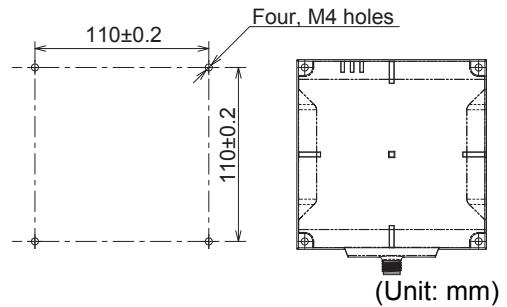

When you install the Reader/Writer, please have the bracket as shown in the figure below.

Material: Steel, SUS

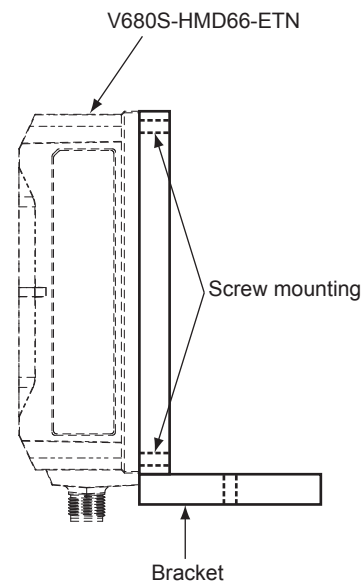
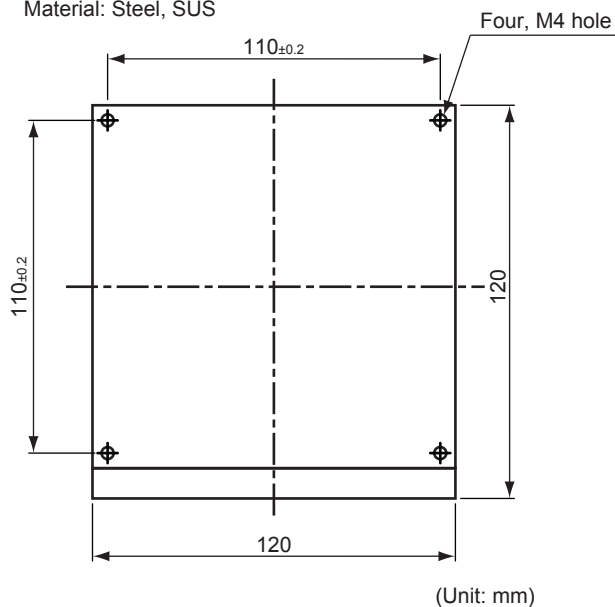

Although it is possible to use aluminum in addition to iron and copper as a mounting bracket, communication performance will change depending on the material. Please do not use resin as a mounting bracket.

CHECK!



The recommended tightening torque for M4 screws is 1.2 N·m.

CHECK!



Refer to *Reader/Writer Installation Precautions* in *Section 8 Appendices* for information of surrounding metal and Mutual Interference of Reader/Writers.

CHECK!

p.164

RF Tag

■ V680-D1KP54T

Either use the V700-A80 Attachment to mount the RF Tags with screws or permanently attach the RF Tags with adhesive.

Installation with the V700-A80 Attachment

1. Place the coin-shaped RF Tag in the Attachment.

The RF Tag can be placed in the Attachment in either direction. The direction does not affect operation.

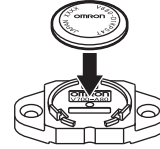

Do not repeatedly place the RF Tag in the Attachment and remove it from the Attachment. If you do so, the RF Tag will become loose or the Attachment will be damaged.

If you must remove an RF Tag from the Attachment, insert a flat-blade screwdriver in the gap under the RF Tag. Do not try to remove it with your bare hands. Doing so may result in injury.

2. Mount the Attachment with M3 screws.

Tighten the screws to a suitable torque.

Tightening torque: 0.3 to 0.5 N·m

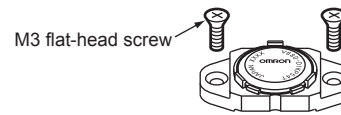

Mounting Hole Dimensions

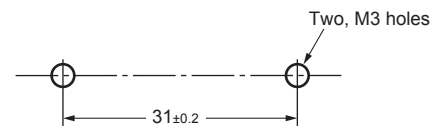

■ Installation with Adhesive

Select an adhesive that is suitable for the materials. Use the correct application method and amount. Always confirm that the RF Tag is securely attached before you use it.

The RF Tags are made from PPS resin. We recommend epoxy adhesives to mount them on metal or hard plastic.

The epoxy adhesives that are listed in the following table are recommended for the given temperature ranges.

Ambient operating temperature	Product name	Manufacturer
-40 to 70°C	Two-part Epoxy Adhesive: TB2001 (main agent)/TB2105C (curing agent)	ThreeBond Co., Ltd.
	One-part Moisture-curing Elastic Adhesive: TB1530	ThreeBond Co., Ltd.
-40 to 110°C	Two-part Epoxy Adhesive: EP001	Cemedine Co. Ltd.
-40 to 150°C	One-part Epoxy Adhesive: TB2285	ThreeBond Co., Ltd.
	Two-part Epoxy Adhesive: TB2087	ThreeBond Co., Ltd.



The above adhesives may not provide sufficient strength when attaching RF Tags to polyethylene, polypropylene, fluororesins, or silicon-based resins. Check applicability carefully in advance. Consult with the manufacturer for detailed information on adhesives.

■ **V680-D1KP66T**

■ **Mounting on Non-metallic Material**

Mount the RF Tag using M3 flat-head screws from the marked side.

Tighten the screws to a torque of 0.3 to 0.5 N·m.

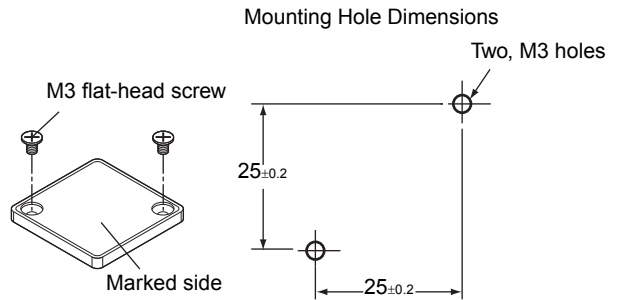



■ **Mounting on Metallic Material**

The communications distance will decrease if there is metal at the back of the V680-D1KP66T RF Tag.

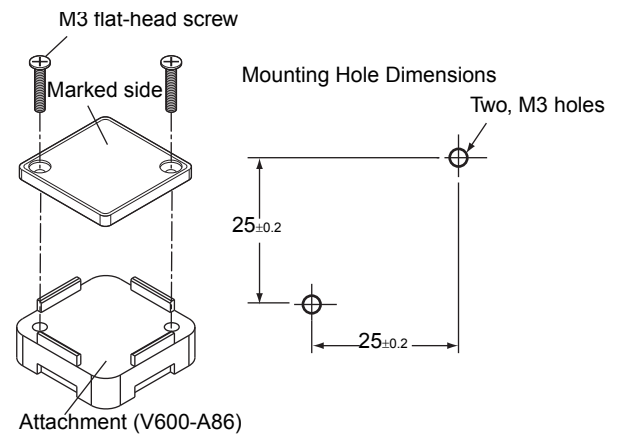
If the RF Tag is mounted on metallic material, use the V600-A86 Attachment (sold separately) or a non-metallic spacer (e.g., plastic or resin).



 Refer to *Influence of Metal at Back Surface* in *Section 8 Appendices* for information on the effect of metal at the back surface of the V680-D1KP66T.

CHECK!  p. 168

■ **V680-D1KP66MT**

Mount the RF Tag using M3 flat-head screws from the marked side.

Tighten the screws to a torque of 0.3 to 0.5 N·m.

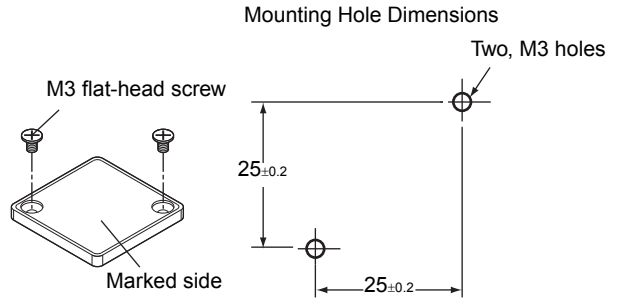

When you install the RF tag, please have the bracket as shown in the figure below.

Material: Steel, SUS

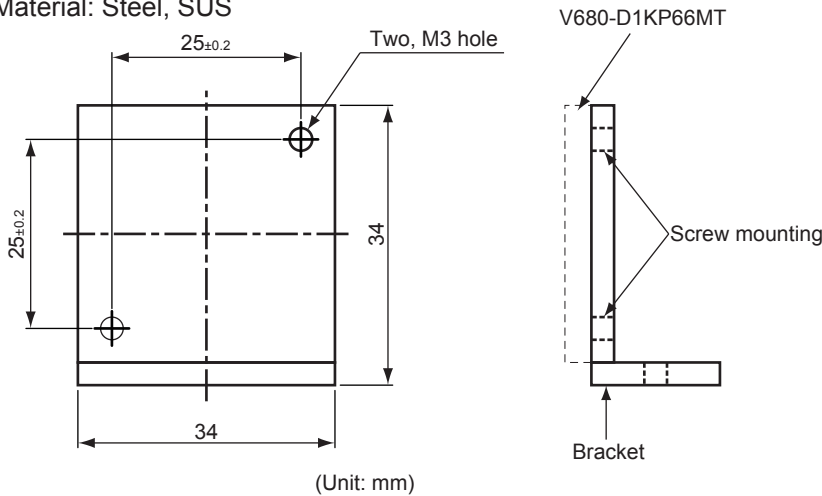

Although it is possible to use aluminum in addition to iron and copper as a mounting bracket, communication performance will change depending on the material. Please do not use resin as a mounting bracket.

CHECK!



Refer to *Influence of Surrounding Metal* in *Section 8 Appendices* for information on the effect of metal at the back surface of the V680-D1KP66MT.

CHECK!

p.170

■ V680-D1KP66T-SP

Mount the RF Tag using M5 screws and washers. The tightening torque is 1.2 N·m.

There are no restrictions on the mounting direction for the RF Tag or the direction of RF Tag travel in respect to the Reader/Writer.

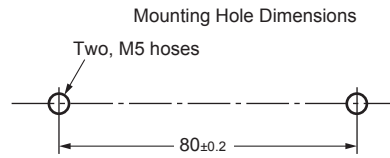
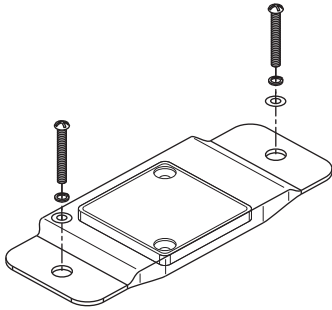

Refer to *Influence of Metal at Back Surface* in *Section 8 Appendices* for information on the effect of metal at the back surface of the V680-D1KP66T-SP.

CHECK!



p.172

■ V680-D1KP58HTN

Use the following procedure to install an RF Tag with the V680-A80 Attachment.

1. Attach the Attachment to the workpiece.

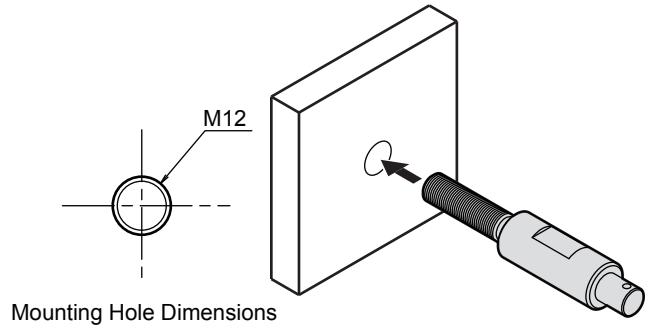

2. Tighten the lock nut.



Use a tightening torque of 21 to 42 N·m.

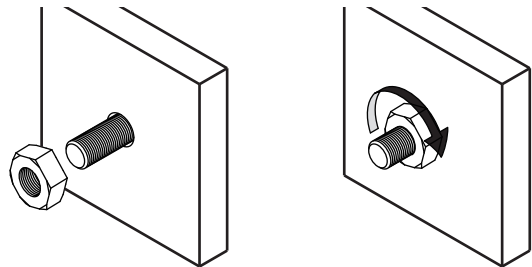

3. Place the RF Tag in the Attachment.



The RF Tag can be attached in either direction. The direction does not affect operation.

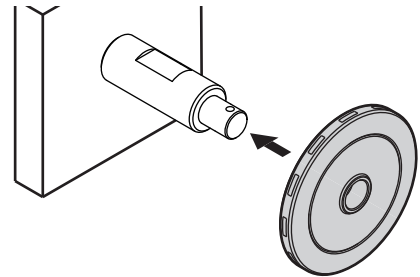

4. Insert the split pin into the 3.2-diameter hole and spread open the end of the pin to prevent it from coming out.

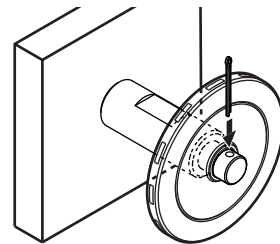

Two nuts and one split pin are provided with the V680-A80 Attachment. You must provide any replacement split pins.

Split pin	Nominal dimensions: 3.2-mm dia. × 20-mm length
-----------	--

■ V680-D8KF67

Mount the RF Tag with M3 screws.
Tighten the screws to a torque of 0.6 N·m.

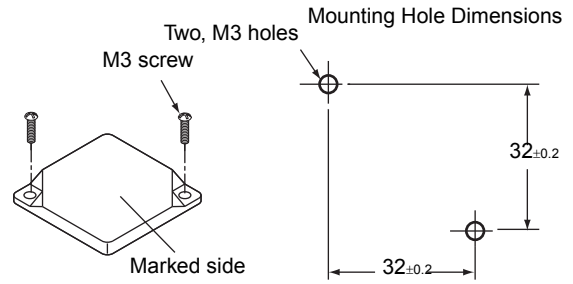

Refer to *Influence of Metal at Back Surface of RF Tags* in *Section 8 Appendices* for information on the effect of metal at the back surface of the V680-D8KF67.



■ V680-D8KF67M

Mount the V680-D8KF67M to a metal surface.
Mount the RF Tag with M3 screws.
Tighten the screws to a torque of 0.6 N·m.

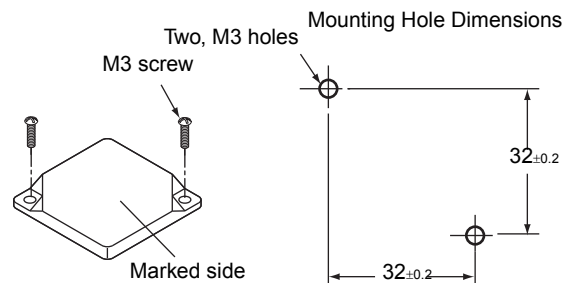

When you install the RF tag, please have the bracket as shown in the figure below.

Material: Steel, SUS

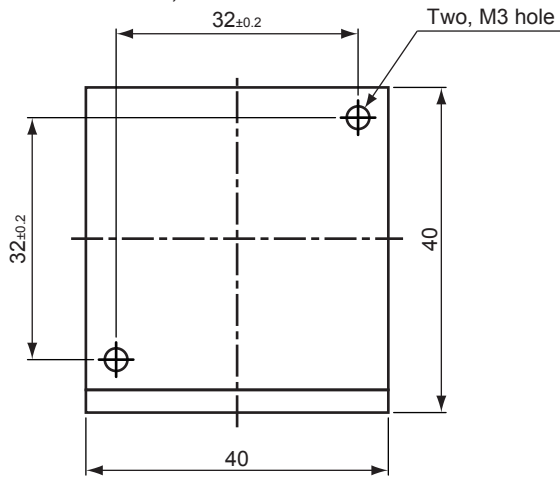

(Unit: mm)

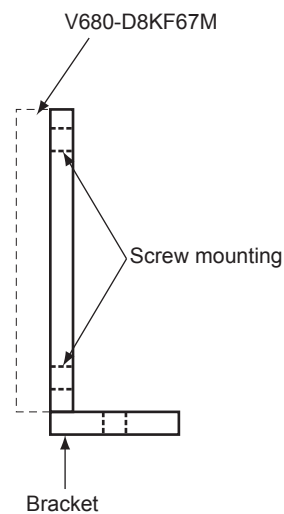

Although it is possible to use aluminum in addition to iron and copper as a mounting bracket, communication performance will change depending on the material. Please do not use resin as a mounting bracket.



Refer to *Influence of Surrounding Metal* in *Section 8 Appendices* for information on the effect of metal at the back surface of the V680-D8KF67M.



■ V680-D8KF68A

Mount the RF Tag with M4 screws.

Tighten the screws to a torque of 0.7 to 1.2 N-m.

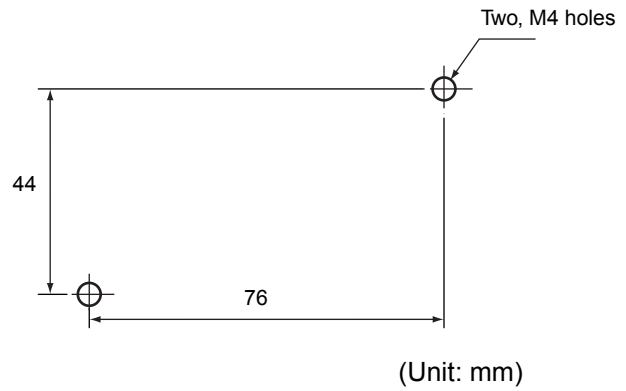
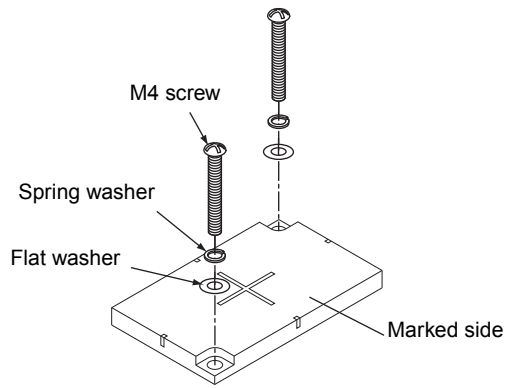

Refer to *Influence of Metal at Back Surface of RF Tags* in *Section 8 Appendices* for information on the effect of metal at the back surface of the V680-D8KF68A.

CHECK!



p.182

Connections and Wiring

Connecting and Removing the Reader/Writer Cable

■ Connecting Method

1. Hold the connector on the Cable and insert it into the connector on the Reader/Writer.

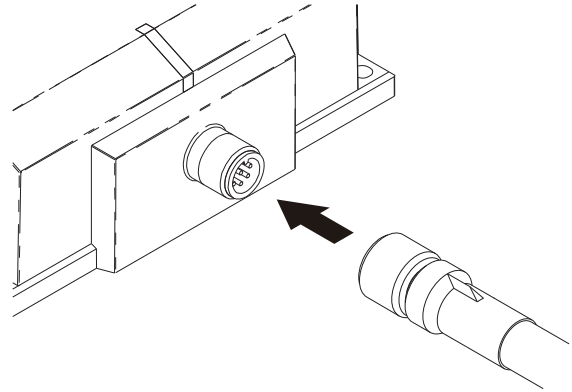

2. Turn the Cable connector clockwise to lock it in place.

Recommended tightening torque: 0.39 to 0.49 N·m

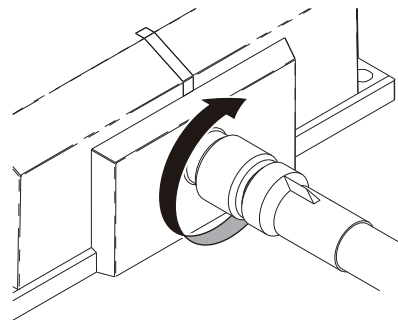

■ Removal Method

1. Turn the Cable connector counterclockwise to release the lock.

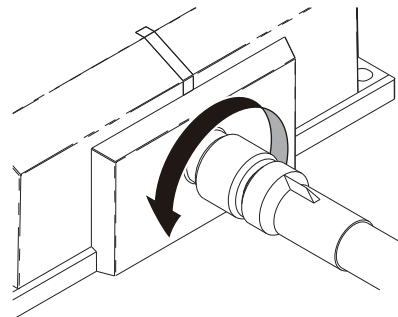

2. Hold the base of the Cable connector and pull it straight out.



CHECK!

If the connector is difficult to remove, press on the Reader/Writer and pull on the connector. Never pull on the Cable with excessive force. Doing so may break the wires and cause malfunction.

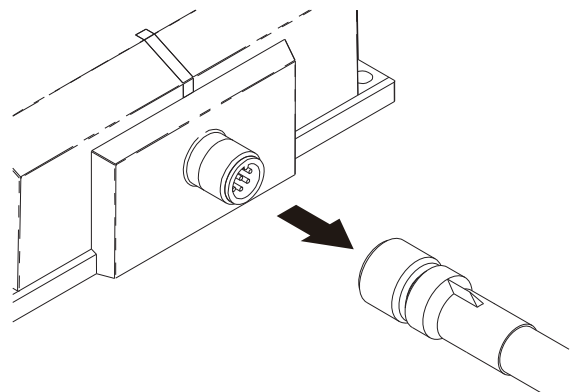

Attaching Ferrite core

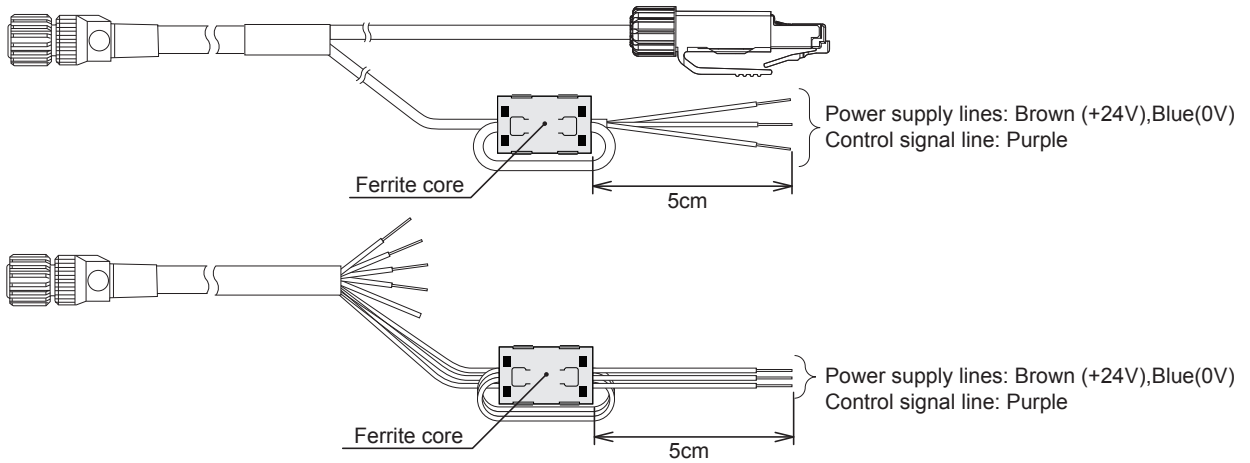

1. Wrap the power supply lines and Control signal line together around the ferrite core once. The ferrite core should be within 5cm from the tip of the cable.

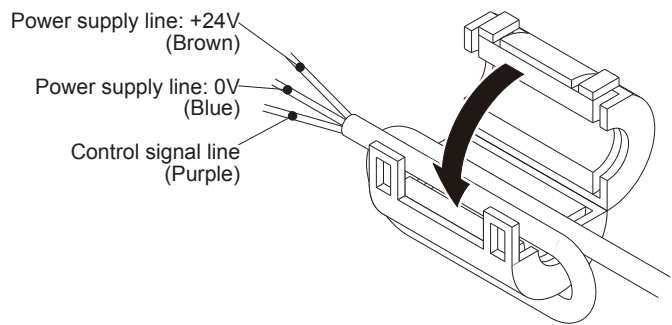

2. Close the ferrite core until you hear it click into place.

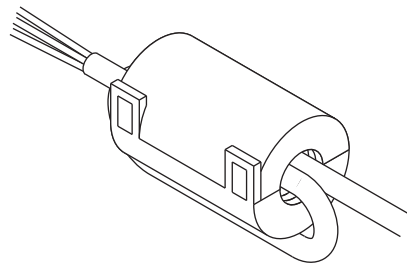



Connecting the V680S-A41□M Cable to the Host Device

Power Supply and Operation Mode Signal

You must connect the power supply lines (24 VDC and 0 VDC) and the operation mode signal line in the V680S-A41□M Cable.

Wire color	Meaning	Connected to	Applicable wire
Brown	24 VDC	+V DC output terminal	AWG20
Blue	0 VDC	-V DC output terminal	
Violet	Control signal	Run Mode: +V DC output terminal Safe Mode: -V DC output terminal*	AWG24

Note: If you start the Reader/Writer with the control signal connected to the -VDC side of the power supply, the Reader/Writer will start in Safe Mode.

 Refer to *Safe Mode* in *Section 7 Troubleshooting* for information on Safe Mode.
 p.136
 CHECK!

 Connect the three terminals correctly. Otherwise, the Reader/Writer may be damaged.
 CHECK!

Power Supply

Use a power source that meets the following conditions.

Conditions

Power supply voltage	Output current	Safety directive
24 VDC +10%, -15%	500 mA DC or higher	UL Class 2

Connecting the Host Device

Connect the RJ45 connector on the V680S-A41□M Cable to an Ethernet port on the host device.

 Press in the connector until it locks into place.
 CHECK!

 Please use a device supporting STP cables for the host device (such as an Ethernet switch or PLC) which is connected the specified Cables (V680S-A41□M). Ground the host device to a ground resistance of 100 Ω or less.

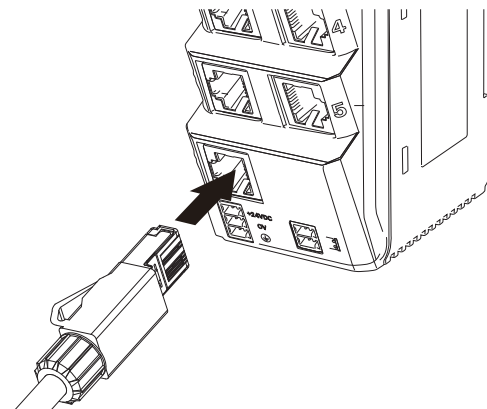

Extending the Cable

■ Connecting Method

1. Insert the connector on the V680S-A41□M Cable into the connector on the V680S-A40□M Extension Cable.

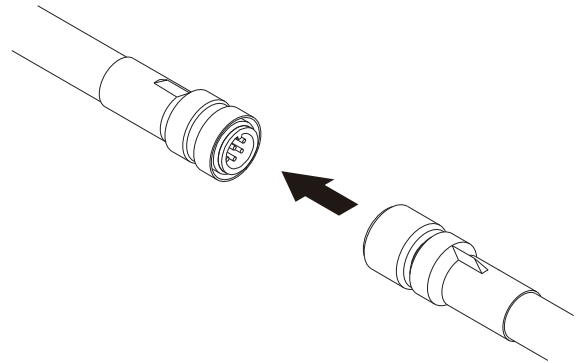

2. Turn the connector on the V680S-A41□M Cable clockwise to lock it in place.
Recommended tightening torque: 0.39 to 0.49 N·m

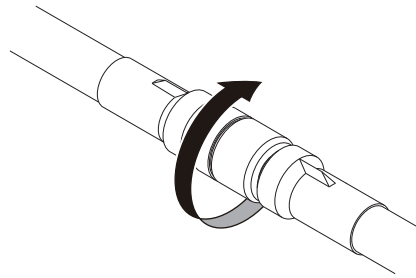

Assembling and Connecting the V680S-A42 □M Cable and Connector

■ Assembly Method

Follow the table below, please assemble the connector.

Please prepare the shielded-connectors according to the application.

Wire color	Name	Function	Applicable wire
Brown	24P	+24V	AWG20
(Drain wire)	FG	Frame ground	---
Purple	CONT	Control signal	AWG24
Orange	TD-	Ethernet send data -	AWG24
Green/White(stripe)	RD+	Ethernet receive data +	AWG24
Orange/White(stripe)	TD+	Ethernet send data +	AWG24
Blue	24N	0V	AWG20
Green	RD-	Ethernet receive data -	AWG24

■ Example Connection

V680S-A42 □M

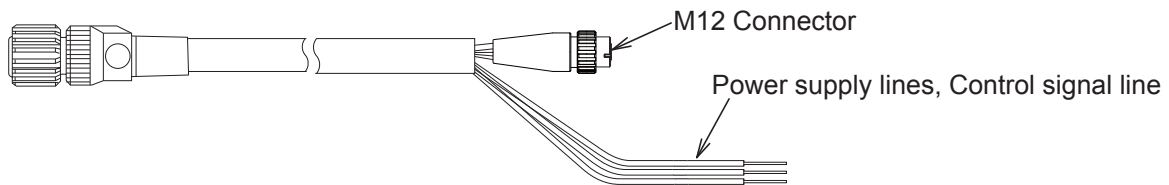

V680S-A42 □M

Wire color	Name	Function
Orange/White	TD+	Ethernet send data +
Orange	TD-	Ethernet send data -
Green/White	RD+	Ethernet receive data +
Green	RD-	Ethernet receive data -

M12 Connector

Name	Function
TXP	Transmitted data (+)
TXN	Transmitted data (-)
RXP	Received data (+)
RXN	Received (-)



Following the instructions of the manufacturer of the connector, please ground connecting the FG with the connector side.

■ Connecting the Host Device

Connect the connector on the V680S-A42 □M Cable to an Ethernet port on the host device.



The Reader/Writer supports for Auto-MDIX, can communicate by both straight and cross ethernet lines.



Please use a device supporting STP cables for the host device (such as an Ethernet switch or PLC) which is connected the specified Cables (V680S-A42 □M). Ground the host device to a ground resistance of 100 Ω or less.

MEMO

Section 4

Preparations for Communications

▣ Starting the Reader/Writer	52
▣ Setting Communications Conditions	53
▣ Communications Test	54

Starting the Reader/Writer

Reader/Writer Starting Procedure

1. Connect the Cable to the Reader/Writer.



CHECK!

Refer to *Connecting and Removing the Reader/Writer Cable* in *Section 3 Installation and Connections* for the connector method.



2. Connect the power supply lines and the operation mode signal line in the Cable to the power source and connect the RJ45 connector to an Ethernet port on the host device.



CHECK!

Refer to *Connecting the V680S-A41□M Cable to the Host Device* in *Section 3 Installation and Connections* for the connector method.



3. Turn ON the power supply to start the Reader/Writer.
If the Reader/Writer starts normally, the RUN indicator will light green.

Setting Communications Conditions

Initial Setting Procedure

Default TCP/IP Network Settings in the Reader/Writer

The default network settings for the Reader/Writer are listed in the following table. Change the network settings of the host device to match those of the Reader/Writer.

IP address	192.168.1.200
Subnet mask	255.255.255.0
Default gateway	192.168.1.254
Port number	502
Port number for Web browser	7090

Host Device Setting Example

IP address: 192.168.1.100
Subnet mask: 255.255.255.0



CHECK!

Refer to *Configuration* in *Section 6 Browser Interface* for Initial Setting method for the Reader/Writer.



p.118

List of Settings

Setting Procedure for Web Server

Enter the settings on the Network Settings display and then click the **Set** Button.



CHECK!

Refer to *Network Settings View* in *Section 6 Browser Interface* for Initial Setting method.



p.111

Setting Procedure for Modbus Queries from the Host Device

You can set the following items with a SET TCP/IP COMMUNICATIONS CONDITIONS query.

- IP address
- Subnet mask
- Gateway address



CHECK!

Refer to *SET TCP/IP COMMUNICATIONS CONDITIONS* in *Section 5 Host Communications Specifications* for Initial Setting Procedure for Modbus Queries from the Host Device.



p.80

If you change the network settings, please restart the Reader/Writer. Settings will be effective after a restart of the Reader/Writer.



CHECK!

Communications Test

Communications Test with Host Device

A communications test is performed to confirm that the host device and Reader/Writer are connected correctly.

Communications Test between Reader/Writer and RF Tags

Send queries from the host device to test communications between the Reader/Writer and the RF Tags.

Section 5

Host Communications Specifications

☒ Modbus Communications Protocol	56
☒ Message Details	68
READ DATA	68
WRITE DATA	69
READ ID	70
COPY DATA	71
DATA FILL	72
LOCK	73
RF TAG OVERWRITE COUNT CONTROL	74
RESTORE DATA	75
SET TAG COMMUNICATIONS OPTION	76
GET TAG COMMUNICATIONS OPTION	77
SET TAG COMMUNICATIONS CONDITIONS	78
GET TAG COMMUNICATIONS CONDITIONS	79
SET TCP/IP COMMUNICATIONS CONDITIONS	80
GET TCP/IP COMMUNICATIONS CONDITIONS	81
SET DEVICE NAME	82
GET DEVICE NAME	83
SET WEB COMMUNICATIONS CONDITIONS	84
GET WEB COMMUNICATIONS CONDITIONS	85
SET WEB PASSWORD	86
GET WEB PASSWORD	87
INITIALIZE SETTINGS	88
GET Model INFORMATION	90
GET FIRMWARE VERSION	91
GET MAC ADDRESS	92
GET Reader/Writer OPERATING STATUS	93
GET OPERATING TIME	94
GET RECENT ERROR QUERY INFORMATION	95
GET COMMUNICATIONS ERROR LOG	97
GET SYSTEM ERROR LOG	99
GET RESTORE INFORMATION	100
STOP	101
RESET	104
☒ Initializing All Settings	105

Modbus Communications Protocol

Communications between the host device and the Reader/Writer are performed on a client-server basis. The computer, PLC, or other host device is the client and the Reader/Writer is the server. Although you can change the setting of the IP address of the Reader/Writer as required, port number 502 is always used for Modbus/TCP communications.

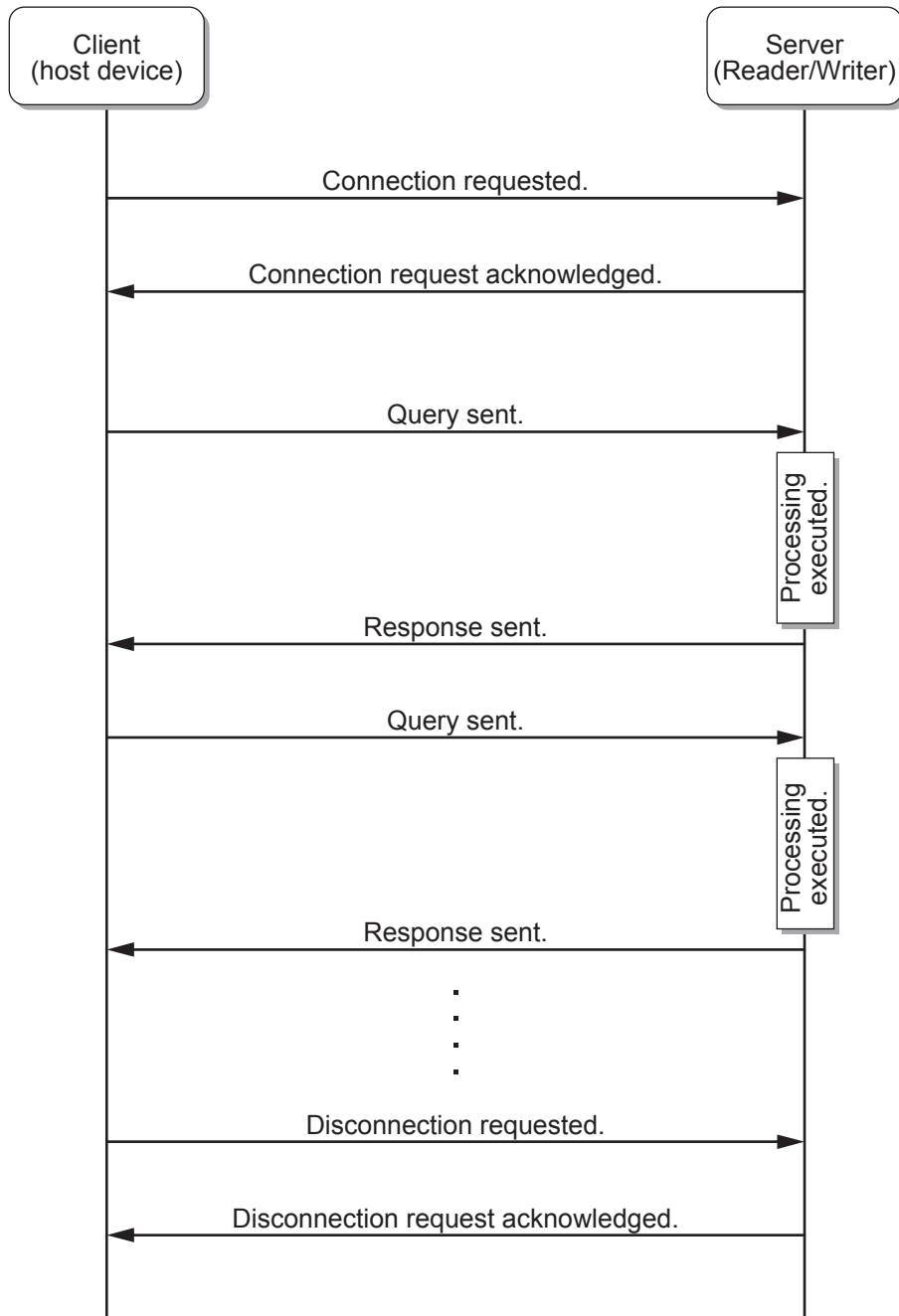

Only one host can be connected to the Reader/Writer. If the Reader/Writer accept the request of connection from host-B while host-A is connected to the Reader/Writer, the connection between the Reader/Writer and host-A will automatically disconnect and the new connection with host-B will be established.

Message Formats

The host device communications protocol that is used by the V680S is based on Modbus/TCP. The command message that the host device sends to the Reader/Writer is called a query. The response message that the Reader/Writer returns is called the response. The communications formats for queries and responses are given below.

■ Query format

Byte 0	Byte 1	Byte 2	Byte 3	Byte 4	Byte 5	Byte 6	Byte 7	Byte 8	Byte 9	...	Byte n
Transaction identifier		Protocol identifier		Field length		Unit identifier	Function code	Data			
X	X	Always 0000 hex		Always 00 hex	No. of bytes	Always FF hex	03 or 10 hex				

X: Any value

Range specified with the field length

Transaction Identifier

You can set any desired value. The transaction identifier in the response from the Reader/Writer will be a copy of the value that is specified here.

Protocol Identifier

This field is always 0000 hex.

Field Length

Specify the number of bytes inclusively from the unit identifier through the end of the data.

Byte 4 will always be 00 hex.

Unit Identifier

This field is always FF hex.

Function code

Specify the function code of the function for the Reader/Writer to execute.

The applicable function codes are listed below.

Function code	Function
03 hex	Read Holding Register
10 hex	Write Holding Register

Data

Send the data for the function code.

The format of the data depends on the function code.

Of the data types that are supported by Modbus communications, the Reader/Writer supports the following data type.

Data name	Description
Holding register	Read/write 16-bit data

Response Format

Normal End

Byte 0	Byte 1	Byte 2	Byte 3	Byte 4	Byte 5	Byte 6	Byte 7	Byte 8	Byte 9	...	Byte n
Transaction identifier		Protocol identifier		Field length		Unit identifier	Function code	Data			
Copy of the transaction identifier that was specified in the query		Always 0000 hex		Always 00 hex	No. of bytes	Always FF hex					

Range specified with the field length

Transaction Identifier

A copy of the value that was specified in the query is returned.

Protocol Identifier

This field is always 0000 hex.

Field Length

The number of bytes inclusively from the unit identifier through the end of the data is specified.

Byte 4 will always be 00 hex.

Unit Identifier

This field is always FF hex.

Function code

The value that was specified in the query (Read: 03 hex or Write: 10 hex) is set.

Function code	Function
03 hex	Read Holding Register
10 hex	Write Holding Register

Data

The data for the function code is sent.

The format of the data depends on the function code.

The Reader/Writer supports the following data type.

Data name	Description
Holding register	Read/write 16-bit data

▪ **Error End**

Byte 0	Byte 1	Byte 2	Byte 3	Byte 4	Byte 5	Byte 6	Byte 7	Byte 8
Transaction identifier		Protocol identifier		Field length		Unit identifier	Function code	Exception code
Copy of the transaction identifier that was specified in the query		Always 0000 hex		Always 00 hex	No. of bytes	Always FF hex		

Range specified with the field length

Transaction Identifier

A copy of the value that was specified in the query is returned.

Protocol Identifier

This field is always 0000 hex.

Field Length

The number of bytes inclusively from the unit identifier through the end of the data is specified. Byte 4 will always be 00 hex.

Unit Identifier

This field is always FF hex.

Function Code

A value of 80 hex is added to the value that was specified in the query and set.

Exception Code

A code that provides information on the error is attached.

Exception code	Meaning
01 hex	Illegal function
02 hex	Illegal data address
03 hex	Illegal data value
04 hex	Failure in slave device
06 hex	Slave device busy

Function Code Descriptions

■ Read Holding Register (03 Hex)

This function code is used to read the contents of the specified number of continuous holding registers starting from the specified address.

■ Example: Reading Four Words of Data Starting from Address 1234 Hex in the RF Tag

Query

No.	Field name	Example (hex)
1	Transaction identifier upper byte	00
2	Transaction identifier lower byte	00
3	Protocol identifier upper byte	00
4	Protocol identifier lower byte	00
5	Field length upper byte	00
6	Field length lower byte	06
7	Unit identifier	FF
8	Function code	03
9	Register address upper byte (See note 1.)	12
10	Register address lower byte (See note 1.)	34
11	Word count upper byte	00
12	Word count lower byte	04

} RF Tag address = Register address



The address in the RF Tag is the same as the register address.

CHECK!

Response

No.	Field name	Example (hex)
1	Transaction identifier upper byte	00
2	Transaction identifier lower byte	00
3	Protocol identifier upper byte	00
4	Protocol identifier lower byte	00
5	Field length upper byte	00
6	Field length lower byte	0B
7	Unit identifier	FF
8	Function code	03
9	Byte count	08
10	Read data 1 upper byte	11
11	Read data 1 lower byte	11
12	Read data 2 upper byte	22
13	Read data 2 lower byte	22
14	Read data 3 upper byte	33
15	Read data 3 lower byte	33
16	Read data 4 upper byte	44
17	Read data 4 lower byte	44

■ Write Holding Register (10 Hex)

This function code is used to write continuous holding registers.

■ Example: Writing “1111222233334444” to Four Words Starting from Address 1234 Hex in the RF Tag

Query

No.	Field name	Example (hex)
1	Transaction identifier upper byte	00
2	Transaction identifier lower byte	00
3	Protocol identifier upper byte	00
4	Protocol identifier lower byte	00
5	Field length upper byte	00
6	Field length lower byte	0F
7	Unit identifier	FF
8	Function code	10
9	Register address upper byte (See note 1.)	12
10	Register address lower byte (See note 1.)	34
11	Word count upper byte	00
12	Word count lower byte	04
13	Byte count	08
14	Write data 1 upper byte	11
15	Write data 1 lower byte	11
16	Write data 2 upper byte	22
17	Write data 2 lower byte	22
18	Write data 3 upper byte	33
19	Write data 3 lower byte	33
20	Write data 4 upper byte	44
21	Write data 4 lower byte	44

} RF Tag address = Register address



The address in the RF Tag is the same as the register address.

CHECK!

Response

No.	Field name	Example (hex)
1	Transaction identifier upper byte	00
2	Transaction identifier lower byte	00
3	Protocol identifier upper byte	00
4	Protocol identifier lower byte	00
5	Field length upper byte	00
6	Field length lower byte	06
7	Unit identifier	FF
8	Function code	10
9	Register address upper byte (See note 1.)	12
10	Register address lower byte (See note 1.)	34
11	Word count upper byte	00
12	Word count lower byte	04

} RF Tag address = Register address

Error Handling

If an error occurs, you can check the error logs in the Reader/Writer to get details on the nature of the error. An error has occurred if the function code in the response that was returned from the Reader/Writer is 80 hex higher than the function code in the query. You can read the error logs by sending a query to get the error log information from the host device or you can read the error logs from a Web browser using the Web server.



Refer to *Error Logs* in *Section 2 Names and Functions of Components* for information on the error logs

 p.29

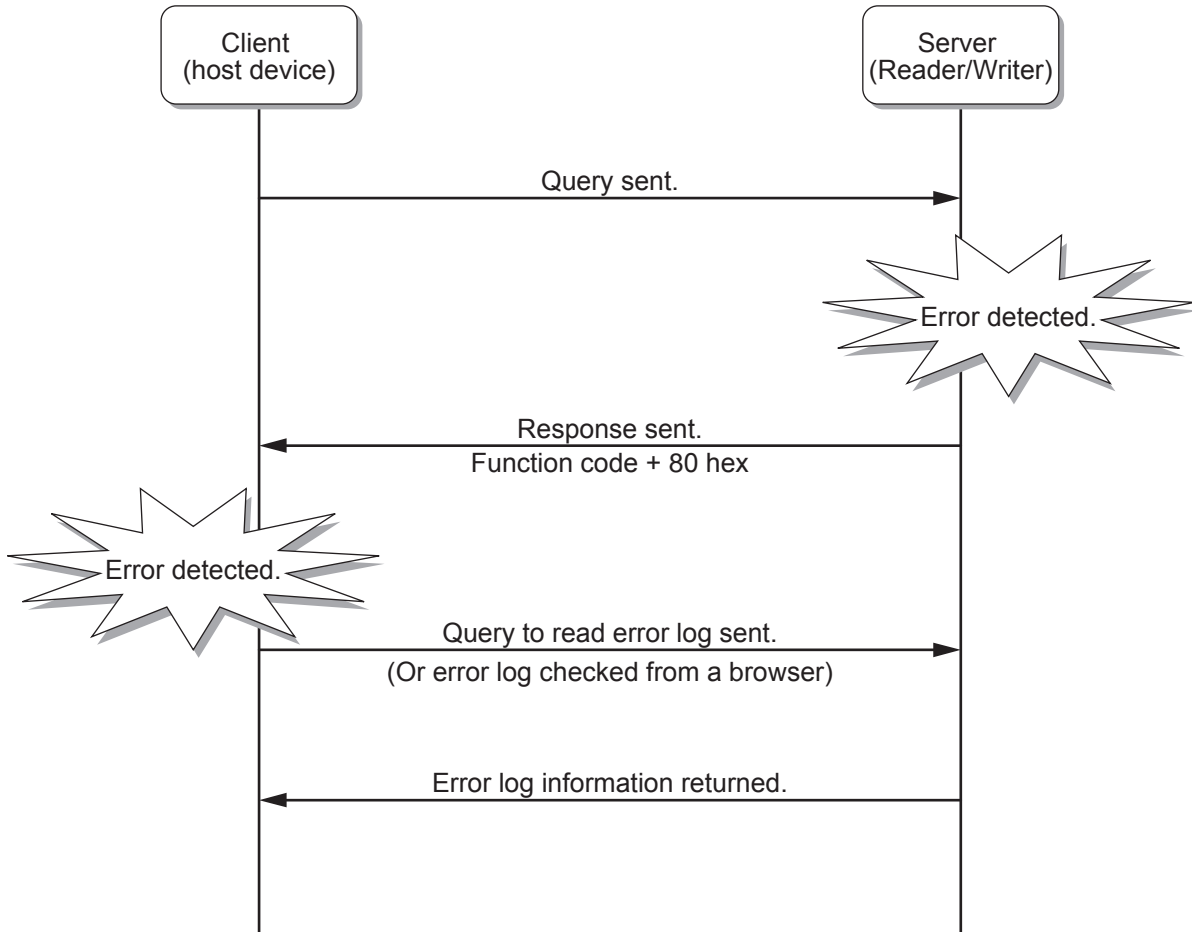

Query Tables

RF Tag Communications

Name	Description	Page
READ DATA	Reads data from an RF Tag in the communications area.	p.68
WRITE DATA	Writes data to an RF Tag in the communications area.	p.69
READ ID	Reads the ID code from an RF Tag in the communications area.	p.70
COPY DATA	Uses two Reader/Writers to copy data from the memory of an RF Tag in the communications area of one Reader/Writer (A) to the memory of the RF Tag in the communications area of another Reader/Writer (B).	p.71
DATA FILL	Writes the specified data to the specified number of words beginning from the specified start address. The specifications are made in the query.	p.72
LOCK	This query locks the specified memory in the RF Tag. It will no longer be possible to write data to the locked memory. The lock cannot be released.	p.73
RF TAG OVERWRITE COUNT CONTROL	Used to manage the number of times data is written to an RF Tag. You can use this query for RF Tags with EEPROM memory.	p.74
RESTORE DATA	This query reads the restore information from the Reader/Writer.	p.75

Reader/Writer Settings

Name	Description	Page
SET TAG COMMUNICATIONS OPTION	Sets the communications option of the Reader/Writer to Once, Auto, or FIFO Trigger.	p.76
GET TAG COMMUNICATIONS OPTION	Reads the communications option of the Reader/Writer (Once, Auto, or FIFO Trigger).	p.77
SET TAG COMMUNICATIONS CONDITIONS	Sets the conditions for Reader/Writer communications with RF Tags (high speed/normal speed and write verification).	p.78
GET TAG COMMUNICATIONS CONDITIONS	Reads the conditions that are set in the Reader/Writer for communications with RF Tags (high speed/normal speed and write verification).	p.79
SET TCP/IP COMMUNICATIONS CONDITIONS	Sets TCP/IP communications.	p.80
GET TCP/IP COMMUNICATIONS CONDITIONS	Reads the TCP/IP information that is set in the Reader/Writer.	p.81
SET DEVICE NAME	Sets a name for the Reader/Writer.	p.82
GET DEVICE NAME	Reads the name that is set in the Reader/Writer.	p.83
SET WEB COMMUNICATIONS CONDITIONS	This query sets the TCP/IP communications conditions of the Reader/Writer.	p.84
GET WEB COMMUNICATIONS CONDITIONS	This query reads the WEB information that is set in the Reader/Writer.	p.85
SET WEB PASSWORD	Sets a password for accessing the Reader/Writer from a Web browser.	p.86
GET WEB PASSWORD	Reads the Web server password that is set in the Reader/Writer.	p.87
INITIALIZE SETTINGS	Returns all of the setting information in the Reader/Writer to the default status.	p.88

■ **Checking Reader/Writer Information**

Name	Description	Page
MEASURE NOISE	Measures the noise level around the Reader/Writer.	p.89
GET DEVICE INFORMATION	Reads the model number from the Reader/Writer.	p.90
GET FIRMWARE VERSION	Reads the firmware version from the Reader/Writer.	p.91
GET MAC ADDRESS	Reads the MAC address from the Reader/Writer.	p.92
GET Reader/Writer OPERATING STATUS	Reads the operating status from the Reader/Writer.	p.93
GET OPERATING TIME	Reads the operating time from when the power supply to the Reader/Writer was turned ON.	p.94
GET RECENT ERROR QUERY INFORMATION	Reads the recent error information from the Reader/Writer.	p.95
GET COMMUNICATIONS ERROR LOG	Reads the log of communications errors that have occurred in the Reader/Writer.	p.97
GET SYSTEM ERROR LOG	Reads the log of system errors (fatal errors) that have occurred in the Reader/Writer.	p.99
GET RESTORE INFORMATION	This query reads the restore information from the Reader/Writer.	p.100

■ **Controlling Reader/Writer Operation**

Name	Description	Page
STOP	Stops Reader/Writer operation.	p.101
RESET	Resets the Reader/Writer.	p.104

Exception Code Table

Exception code	Meaning
00 hex	Normal end
01 hex	Illegal function <ul style="list-style-type: none"> • Frame header values are incorrect. • The function code is incorrect. • The frame length is incorrect.
02 hex	Illegal data address <ul style="list-style-type: none"> • The value in the address field is incorrect.
03 hex	Illegal data value <ul style="list-style-type: none"> • A parameter value is incorrect.
04 hex	Failure in slave device <ul style="list-style-type: none"> • The Reader/Writer detected an error (error in RF Tag communications, hardware fault, etc.).
06 hex	Slave device busy <ul style="list-style-type: none"> • The query cannot be executed.

■ End Codes

The end code consists of two words in the format that is shown in the following table.

Error code	Model number information	(Reserved)
		Always 00 hex
2 bytes	1 byte	1 byte

■ Error Codes

The error code consists of two bytes that give the result of Reader/Writer processing.



For details on the error codes, refer to *Error Codes* in this section.

CHECK!  p.66

■ Model Number Information

Information on the device where the error occurred is given in one byte.

Model number information	Meaning
00 hex	An error occurred in the local device.
01 hex	An error occurred in the other Reader/Writer. If the COPY DATA query is sent and the error occurred at the copy destination Reader/Writer, the error source model number information is set to 01 hex.

■ **Error Codes**

If an exception code other than 00 hex (normal operation) is returned in the response from the Reader/Writer, you can use a GET COMMUNICATIONS ERROR LOG query to get details on the nature of the error.

The following tables list the error codes that indicate the response results from the Reader/Writer. If an error response is returned (i.e., an error code other than 0000 hex), a record is recorded in the communications error log in the Reader/Writer. Records are not recorded for errors for which responses are not returned to the host device. Reader/Writer operating errors and system errors are recorded in the system error log in the Reader/Writer.

■ **Normal Code**

Error code name	Error code	Description
Normal end	0000 hex	Processing ended normally.

■ **Interrupted Processing**

Error code name	Error code	Description
Communications canceled	0001 hex	Processing was canceled when a STOP query was received before an RF Tag was detected. (The contents of the RF Tag was not changed, even for a WRITE DATA query.)
Communications aborted	0002 hex	Processing was aborted when a STOP query was received during communications with an RF Tag. (For a WRITE DATA query, the contents of the RF Tag may have been changed.)

■ **Query Errors**

Error code name	Error code	Description
Frame length error	1001 hex	A frame with a length that exceeded the protocol specification was received.
Frame header error	1002 hex	The frame header did not agree with the protocol specifications.
Illegal query error	1003 hex	A query that is not supported by the Reader/Writer was received.
Query format error	1004 hex	There was an error in the format of the received query data.
Query parameter error	1005 hex	There was an error in the parameters in the received query data.
Execution status error	1006 hex	The Reader/Writer could not execute the query that was received.
Query response error*1	1010 hex	A response could not be returned for a query that was received by the Reader/Writer. (An example would be a TCP/IP socket communications send failure.)

*1. If a query response error occurs, the response from the Reader/Writer may not be received by the host device. Reconnect to the Reader/Writer and check the cause of the error with a GET COMMUNICATIONS ERROR LOG query.

▪ **RF Tag Communications Errors**

Error code name	Error code	Description
RF Tag missing error	2001 hex	There is no RF Tag in the communications area.
RF Tag communications error	2002 hex	Communications with the RF Tag did not end normally.
UID mismatch error	2003 hex	An RF Tag with the specified ID was not in the communications area.
RF Tag address error	2004 hex	The access address for the RF Tag is outside of the area supported by the target RF Tag.
RF Tag lock error	2005 hex	An attempt was made to write data to a locked area.
RF Tag verification error	2006 hex	Processing to write data to the RF Tag did not end normally.
RF Tag data lost error	2007 hex	Processing to write data to the RF Tag did not end normally. (Data may have been lost and must be restored.)
RF Tag system error	2008 hex	The RF Tag returned an error response.
RF Tag overwriting error	2009 hex	The overwrite limit was exceeded for overwrite count control processing.
Reader/Writer connection error	200A hex	When copying data, communications could not be established with the copy destination Reader/Writer.

▪ **Reader/Writer Operation Errors**

Error code name	Error code	Description
Unfixed operation mode error	8001 hex	The control signal was not stable when the Reader/Writer was started. A record is recorded only in the system error log.
User setting error	8002 hex	An error was detected in user configuration memory when the Reader/Writer was started. A record is recorded only in the system error log. The Attached information1, representing the erroneous classification settings. 00000001 hex: Network settings 00000002 hex: RF Tag communication settings

▪ **System Errors**

Error code name	Error code	Description
System startup errors		
System memory error	F001 hex	An error was detected in system memory. A record is recorded only in the system error log.
Profile error	F002 hex	An error was detected in the profile data. A record is recorded only in the system error log.
Hardware fault		
IC error	F011 hex	An error was detected in an IC in the Reader/Writer.
Configuration memory error	F012 hex	An error was detected when accessing configuration memory.

Message Details

RF Tag Communications

■ READ DATA

This query reads data from an RF Tag in the communications area.

■ Query Format

Byte 0	Byte 1	Byte 2	Byte 3	Byte 4	Byte 5	Byte 6	Byte 7	Byte 8	Byte 9	Byte 10	Byte 11
Transaction identifier		Protocol identifier		Field length		Unit identifier	Function code	Register address		Word count	
X	X	0000 hex		0006 hex		FF hex	03 hex				

Parameter	Description
Register address	Specify in 4-digit hexadecimal the start address for reading data. Setting range: 0000 to 9FFF hex (Specify a word address.)
Word count	Specify in 4-digit hexadecimal the number of words of data to read. Setting range: 0001 to 007D hex

■ Response Format

Normal Response

Byte 0	Byte 1	Byte 2	Byte 3	Byte 4	Byte 5	Byte 6	Byte 7	Byte 8	Byte 9	...	Byte n
Transaction identifier		Protocol identifier		Field length		Unit identifier	Function code	Byte count	Read data		
X	X	0000 hex		00 hex		FF hex	03 hex				

Parameter	Description
Byte count	Contains the number of bytes of data that was read from the RF Tag in 2-digit hexadecimal. (02 to FA hex)
Read data	The data that was read from the RF Tag is attached.

Error Response

Byte 0	Byte 1	Byte 2	Byte 3	Byte 4	Byte 5	Byte 6	Byte 7	Byte 8
Transaction identifier		Protocol identifier		Field length		Unit identifier	Function code	Exception code
X	X	0000 hex		0003 hex		FF hex	83 hex	

Parameter	Description
Exception code	For details, refer to <i>Exception Code Table</i> in this section.  p.65

■ Execution Example

Reading Eight Words of Data Starting from Word Address 1234 Hex in the RF Tag

TX: 000000000006FF0312340008

RX: 00000000013FF03101111222333344445555666677778888

■ WRITE DATA

This query writes data to an RF Tag in the communications area.

■ Query Format

Byte 0	Byte 1	Byte 2	Byte 3	Byte 4	Byte 5	Byte 6	Byte 7	Byte 8	Byte 9	Byte 10	Byte 11	Byte 12	Byte 13	...	Byte n
Transaction identifier		Protocol identifier		Field length		Unit identifier	Function code	Register address		Word count		Byte count	Write data		
X	X	0000 hex		0006 hex		FF hex	10 hex								

Parameter	Description
Register address	Specify in 4-digit hexadecimal the start address for writing data to the RF Tag. Setting range: 0000 to 9FFF hex (Specify a word address.)
Word count	Specify in 4-digit hexadecimal the number of words of data to write. Setting range: 0001 to 0071 hex
Byte count	Specify in 4-digit hexadecimal the number of bytes of data to write. Setting range: 02 to E2 hex
Write data	Specify the data to write to the RF Tag. Between 1 and 113 words of data can be written with one query.

■ Response Format

Normal Response

Byte 0	Byte 1	Byte 2	Byte 3	Byte 4	Byte 5	Byte 6	Byte 7	Byte 8	Byte 9	Byte 10	Byte 11
Transaction identifier		Protocol identifier		Field length		Unit identifier	Function code	Register address		Word count	
X	X	0000 hex		0006 hex		FF hex	10 hex				

Parameter	Description
Register address	Contains the register address that was specified in the query.
Word count	Contains the word count that was specified in the query.

Error Response

Byte 0	Byte 1	Byte 2	Byte 3	Byte 4	Byte 5	Byte 6	Byte 7	Byte 8
Transaction identifier		Protocol identifier		Field length		Unit identifier	Function code	Exception code
X	X	0000 hex		0003 hex		FF hex	90 hex	

Parameter	Description
Exception code	For details, refer to <i>Exception Code Table</i> in this section.  p.65

■ Execution Example

Writing "1111222233334444" to Four Words Starting from Word Address 1234 Hex in the RF Tag

TX: 000000000000FFF1012340004081111222233334444

RX: 000000000006FF1012340004

■ READ ID

This query reads the ID code from an RF Tag in the communications area.

■ Query Format

Byte 0	Byte 1	Byte 2	Byte 3	Byte 4	Byte 5	Byte 6	Byte 7	Byte 8	Byte 9	Byte 10	Byte 11
Transaction identifier		Protocol identifier		Field length		Unit identifier	Function code	Register address		Word count	
X	X	0000 hex		0006 hex		FF hex	03 hex	A000 hex		0004 hex	

Parameter	Description
Register address	The register address (A000 hex) that specifies reading the ID.
Word count	The number of words of data to read (0004 hex)

■ Response Format

Normal Response

Byte 0	Byte 1	Byte 2	Byte 3	Byte 4	Byte 5	Byte 6	Byte 7	Byte 8	Byte 9	...	Byte 16
Transaction identifier		Protocol identifier		Field length		Unit identifier	Function code	Byte count	Read data		
X	X	0000 hex		000B hex		FF hex	03 hex	08 hex			

Parameter	Description
Byte count	The number of bytes in the UID data that was read from the RF Tag (08 hex)
Read data	The UID data that was read from the RF Tag is attached.

Error Response

Byte 0	Byte 1	Byte 2	Byte 3	Byte 4	Byte 5	Byte 6	Byte 7	Byte 8
Transaction identifier		Protocol identifier		Field length		Unit identifier	Function code	Exception code
X	X	0000 hex		0003 hex		FF hex	83 hex	

Parameter	Description
Exception code	For details, refer to <i>Exception Code Table</i> in this section.  p.65

■ Execution Example

Reading the UID Data (1122334455667788 hex) from an RF Tag

TX: 000000000006FF03A0000004

RX: 0000000000BFF03081122334455667788

■ COPY DATA

This query uses two Reader/Writers to copy data from the memory of an RF Tag in the communications area of one Reader/Writer (A) to the memory of the RF Tag in the communications area of another Reader/Writer (B).

■ Query Format

Byte 0	Byte 1	Byte 2	Byte 3	Byte 4	Byte 5	Byte 6	Byte 7	Byte 8	Byte 9	Byte 10	Byte 11	Byte 12
Transaction identifier		Protocol identifier		Field length		Unit identifier	Function code	Register address		Word count		Byte count
X	X	0000 hex		000F hex		FF hex	10 hex	A800 hex		0004 hex		08 hex

Byte 13	Byte 14	Byte 15	Byte 16	Byte 17	Byte 18	Byte 19	Byte 20
Copy address		Copy word count		IP address			

Parameter	Description
Register address	The register address (A800 hex) that specifies the copying query.
Word count	The number of words of data to read (0004 hex)
Byte count	The number of bytes of data to read (08 hex)
Copy address	Specify in 4-digit hexadecimal the start address for writing the copied data in the RF Tag. Setting range: 0000 to 9FFF hex (Specify a word address.)
Copy word count	Specify in 4-digit hexadecimal the number of words of data to copy. Setting range: 0001 to 0066 hex (1 to 102)
IP address	The IP address of the copy destination Reader/Writer in 32 bits Example: C0A801C8 hex (192.168.1.200)

■ Response Format

Normal Response

Byte 0	Byte 1	Byte 2	Byte 3	Byte 4	Byte 5	Byte 6	Byte 7	Byte 8	Byte 9	Byte 10	Byte 11
Transaction identifier		Protocol identifier		Field length		Unit identifier	Function code	Register address		Word count	
X	X	0000 hex		0006 hex		FF hex	10 hex	A800 hex		0004 hex	

Parameter	Description
Register address	Contains the register address that was specified in the query.
Word count	Contains the word count that was specified in the query.

Error Response

Byte 0	Byte 1	Byte 2	Byte 3	Byte 4	Byte 5	Byte 6	Byte 7	Byte 8
Transaction identifier		Protocol identifier		Field length		Unit identifier	Function code	Exception code
X	X	0000 hex		0003 hex		FF hex	90 hex	

Parameter	Description
Exception code	For details, refer to <i>Exception Code Table</i> in this section.  p.65

■ Execution Example

Copying Four Words of Data Starting from Word Address 1234 Hex in the RF Tag to the RF Tag in the Communications Area of the Reader/Writer at IP Address 192.168.1.201

TX: 0000000000FFF10A80000040812340004C0A801C9

RX: 000000000006FF10A8000004

■ DATA FILL

This query writes the specified data to the specified number of words beginning from the specified start address. The specifications are made in the query.

■ Query Format

Byte 0	Byte 1	Byte 2	Byte 3	Byte 4	Byte 5	Byte 6	Byte 7	Byte 8	Byte 9	Byte 10	Byte 11	Byte 12	Byte 13	...	Byte 18
Transaction identifier		Protocol identifier		Field length		Unit identifier	Function code	Register address		Word count		Byte count		Fill information	
X	X	0000 hex		000D hex		FF hex	10 hex	A100 hex		0003 hex		06 hex			

Byte 13	Byte 14	Byte 15	Byte 16	Byte 17	Byte 18
Fill address		Number of fill words		Fill data	

Parameter	Description	
Register address	The register address (A100 hex) that specifies filling data.	
Word count	Number of words of fill information (0003 hex)	
Byte count	Number of bytes of fill information (06 hex)	
Fill information	Fill address	Specify in 4-digit hexadecimal the start address for writing data in the RF Tag. Setting range: 0000 to 9FFF hex (Specify a word address.)
	Number of fill words	Specify in 4-digit hexadecimal the number of words of data to fill. Setting range: 0001 to FFFF hex (Specify 0000 hex to fill the entire area.)
	Fill data	Specify in 4-digit hexadecimal the data to write to the RF Tag.

■ Response Format

Normal Response

Byte 0	Byte 1	Byte 2	Byte 3	Byte 4	Byte 5	Byte 6	Byte 7	Byte 8	Byte 9	Byte 10	Byte 11
Transaction identifier		Protocol identifier		Field length		Unit identifier	Function code	Register address		Word count	
X	X	0000 hex		0006 hex		FF hex	10 hex	A100 hex		0003 hex	

Parameter	Description
Register address	Contains the register address that was specified in the query.
Word count	Contains the word count that was specified in the query.

Error Response

Byte 0	Byte 1	Byte 2	Byte 3	Byte 4	Byte 5	Byte 6	Byte 7	Byte 8
Transaction identifier		Protocol identifier		Field length		Unit identifier	Function code	Exception code
X	X	0000 hex		0003 hex		FF hex	90 hex	

Parameter	Description
Exception code	For details, refer to <i>Exception Code Table</i> in this section.  p.65

■ Execution Example

Filling 5A5A Hex to Four Words Starting from Word Address 1234 Hex in the RF Tag

TX: 0000000000DFF10A100000306123400045A5A

RX: 000000000006FF10A1000003

LOCK

This query locks the specified memory in the RF Tag.

It will no longer be possible to write data to the locked memory. The lock cannot be released.

Query Format

Byte 0	Byte 1	Byte 2	Byte 3	Byte 4	Byte 5	Byte 6	Byte 7	Byte 8	Byte 9	Byte 10	Byte 11	Byte 12	Byte 13	...	Byte 16
Transaction identifier		Protocol identifier		Field length		Unit identifier	Function code	Register address		Word count		Byte count	Lock information		
X	X	0000 hex		000B hex		FF hex	10 hex	A200 hex		0002 hex		04 hex			

Byte 13	Byte 14	Byte 15	Byte 16
Lock number		Lock count	

Parameter	Description	
Register address	The register address (A200 hex) that specifies locking memory.	
Word count	Number of words of lock information (0002 hex)	
Byte count	Number of bytes of lock information (04 hex)	
Lock information	Lock number	Specify in 4-digit hexadecimal the first sector number to lock.
	Lock count	Specify in 4-digit hexadecimal the number of sectors to lock.

 Unit to lock depends on the RF tag.
For details, refer to *RF Tag Memory Map* in *Section 8 Appendices*.

CHECK!  p.186

Response Format

Normal Response

Byte 0	Byte 1	Byte 2	Byte 3	Byte 4	Byte 5	Byte 6	Byte 7	Byte 8	Byte 9	Byte 10	Byte 11
Transaction identifier		Protocol identifier		Field length		Unit identifier	Function code	Register address		Word count	
X	X	0000 hex		0006 hex		FF hex	10 hex	A200 hex		0002 hex	

Parameter	Description
Register address	Contains the register address that was specified in the query.
Word count	Contains the word count that was specified in the query.

Error Response

Byte 0	Byte 1	Byte 2	Byte 3	Byte 4	Byte 5	Byte 6	Byte 7	Byte 8
Transaction identifier		Protocol identifier		Field length		Unit identifier	Function code	Exception code
X	X	0000 hex		0003 hex		FF hex	90 hex	

Parameter	Description
Exception code	For details, refer to <i>Exception Code Table</i> in this section.  p.65

Execution Example

Locking Four Sectors Starting from Sector 2 in the RF Tag

TX: 0000000000BFF10A20000020400020004

RX: 000000000006FF10A02000002

RF TAG OVERWRITE COUNT CONTROL

This query is used to manage the number of times data is written to an RF Tag. You can use this query for RF Tags with EEPROM memory.

Query Format

Byte 0	Byte 1	Byte 2	Byte 3	Byte 4	Byte 5	Byte 6	Byte 7	Byte 8	Byte 9	Byte 10	Byte 11	Byte 12	Byte 13	...	Byte 20
Transaction identifier		Protocol identifier		Field length		Unit identifier	Function code	Register address		Word count		Byte count	Overwrite count information		
X	X	0000 hex		000F hex		FF hex	10 hex	A300 hex		0004 hex		08 hex			

Byte 13	Byte 14	Byte 15	Byte 16	Byte 17	Byte 18	Byte 19	Byte 20
Operation		Address		Count			

Parameter	Description	
Register address	The register address (A300 hex) that specifies overwrite count control.	
Word count	The number of words of overwrite count information (0004 hex)	
Byte count	The number of bytes of overwrite count information (08 hex)	
Overwrite count information	Operation	Initialize: 0000 hex, Subtract: 0001 hex, Add: 0002 hex
	Address	Specify in 4-digit hexadecimal the start address of the overwrite count control area in the RF Tag. Setting range: 0000 to 9FFF hex
	Count	Specify the count in 8-digit hexadecimal.

Response Format

Normal Response

Byte 0	Byte 1	Byte 2	Byte 3	Byte 4	Byte 5	Byte 6	Byte 7	Byte 8	Byte 9	Byte 10	Byte 11
Transaction identifier		Protocol identifier		Field length		Unit identifier	Function code	Register address		Number of words of overwrite count information	
X	X	0000 hex		0006 hex		FF hex	10 hex	A300 hex		0004 hex	

Parameter	Description
Register address	Contains the register address that was specified in the query.
Number of words of overwrite count information	Contains the word count that was specified in the query.

Error Response

Byte 0	Byte 1	Byte 2	Byte 3	Byte 4	Byte 5	Byte 6	Byte 7	Byte 8
Transaction identifier		Protocol identifier		Field length		Unit identifier	Function code	Exception code
X	X	0000 hex		0003 hex		FF hex	90 hex	

Parameter	Description
Exception code	For details, refer to <i>Exception Code Table</i> in this section.  p.65

Execution Example

Setting 5,000 (1388 Hex) as the Count in Overwrite Count Address 0080 Hex in the RF Tag with an Addition Specification

TX: 0000000000FFF10A3000004080000008000001388

RX: 00000000006FF10A3000004

■ RESTORE DATA

We will restore the data of RF tags that hold the Reader/Writer.

Restoring to a RF tag can be performed only if the RF tag that matches the UID that holds exists in the communication area.

■ Query Format

Byte 0	Byte 1	Byte 2	Byte 3	Byte 4	Byte 5	Byte 6	Byte 7	Byte 8	Byte 9	Byte 10	Byte 11	Byte 12	Byte 13	...	Byte n
Transaction identifier		Protocol identifier		Field length		Unit identifier	Function code	Register address		Word count		Byte count	Option		
X	X	0000 hex		0009 hex		FF hex	10 hex	A400 hex		0001 hex		02 hex	0000 hex		

Parameter	Description
Register address	The register address (A400 hex) that specifies restoration data.
Word count	The number of words for the option (0001 hex)
Byte count	The number of bytes for the option (02 hex)
Option	Always 0000 hex.

■ Response Format

Normal Response

Byte 0	Byte 1	Byte 2	Byte 3	Byte 4	Byte 5	Byte 6	Byte 7	Byte 8	Byte 9	Byte 10	Byte 11
Transaction identifier		Protocol identifier		Field length		Unit identifier	Function code	Register address		Word count	
X	X	0000 hex		0006 hex		FF hex	10 hex	A400 hex		0001 hex	

Parameter	Description
Register address	Contains the register address that was specified in the query.
Word count	Contains the word count that was specified in the query.

Error Response

Byte 0	Byte 1	Byte 2	Byte 3	Byte 4	Byte 5	Byte 6	Byte 7	Byte 8
Transaction identifier		Protocol identifier		Field length		Unit identifier	Function code	Exception code
X	X	0000 hex		0003 hex		FF hex	90 hex	

Parameter	Description
Exception code	For details, refer to <i>Exception Code Table</i> in this section.  p.65

■ Execution Example

Restore the data

TX: 000000000009FF10A4000001020000

RX: 000000000006FF10A4000001

Reader/Writer Settings

■ SET TAG COMMUNICATIONS OPTION

This query sets the communications option of the Reader/Writer to Once, Auto, or FIFO Trigger.

■ Query Format

Byte 0	Byte 1	Byte 2	Byte 3	Byte 4	Byte 5	Byte 6	Byte 7	Byte 8	Byte 9	Byte 10	Byte 11	Byte 12	Byte 13	Byte 14
Transaction identifier		Protocol identifier		Field length		Unit identifier	Function code	Register address		Word count		Byte count	Tag communications option setting	
X	X	0000 hex		0009 hex		FF hex	10 hex	B000 hex		0001 hex		02 hex		

Parameter	Description
Register address	The register address (B000 hex) that specifies the RF Tag communications option setting.
Word count	Number of words of data (0001 hex)
Byte count	Number of bytes of data (02 hex)
Tag communications option setting	Specify the RF Tag communications option in 4-digit hexadecimal. Once: 0000 hex (default), Auto: 0001 hex, FIFO trigger: 0002 hex

■ Response Format

Normal Response

Byte 0	Byte 1	Byte 2	Byte 3	Byte 4	Byte 5	Byte 6	Byte 7	Byte 8	Byte 9	Byte 10	Byte 11
Transaction identifier		Protocol identifier		Field length		Unit identifier	Function code	Register address		Word count	
X	X	0000 hex		0006 hex		FF hex	10 hex	B000 hex		0001 hex	

Parameter	Description
Register address	Contains the register address that was specified in the query.
Word count	Contains the word count that was specified in the query.

Error Response

Byte 0	Byte 1	Byte 2	Byte 3	Byte 4	Byte 5	Byte 6	Byte 7	Byte 8
Transaction identifier		Protocol identifier		Field length		Unit identifier	Function code	Exception code
X	X	0000 hex		0003 hex		FF hex	90 hex	

Parameter	Description
Exception code	For details, refer to <i>Exception Code Table</i> in this section.  p.65

■ Execution Example

Setting the Communications Option to Auto

TX: 000000000009FF10B0000001020001

RX: 000000000006FF10B0000001

■ GET TAG COMMUNICATIONS OPTION

This query leads the communications option of the Reader/Writer (Once, Auto, or FIFO Trigger).

■ Query Format

Byte 0	Byte 1	Byte 2	Byte 3	Byte 4	Byte 5	Byte 6	Byte 7	Byte 8	Byte 9	Byte 10	Byte 11
Transaction identifier		Protocol identifier		Field length		Unit identifier	Function code	Register address		Word count	
X	X	0000 hex		0006 hex		FF hex	03 hex	B000 hex		0001 hex	

Parameter	Description
Register address	The register address (B000 hex) that specifies the RF Tag communications option setting.
Word count	The number of words in the communications option setting to read (0001 hex)

■ Response Format

Normal Response

Byte 0	Byte 1	Byte 2	Byte 3	Byte 4	Byte 5	Byte 6	Byte 7	Byte 8	Byte 9	Byte 10
Transaction identifier		Protocol identifier		Field length		Unit identifier	Function code	Byte count	Tag communications option setting	
X	X	0000 hex		0005 hex		FF hex	03 hex	02 hex		

Parameter	Description
Byte count	The number of bytes in the communications option setting data that was read (02 hex)
Tag communications option setting	Once: 0000 hex, Auto: 0001 hex, FIFO trigger: 0002 hex

Error Response

Byte 0	Byte 1	Byte 2	Byte 3	Byte 4	Byte 5	Byte 6	Byte 7	Byte 8
Transaction identifier		Protocol identifier		Field length		Unit identifier	Function code	Exception code
X	X	0000 hex		0003 hex		FF hex	83 hex	

Parameter	Description
Exception code	For details, refer to <i>Exception Code Table</i> in this section.  p.65

■ Execution Example

Reading the Communications Option Setting When It Is Auto

TX: 000000000006FF03B0000001

RX: 000000000005FF03020001

■ SET TAG COMMUNICATIONS CONDITIONS

This query sets the conditions for Reader/Writer communications with RF Tags (high speed/normal speed and write verification).

■ Query Format

Byte 0	Byte 1	Byte 2	Byte 3	Byte 4	Byte 5	Byte 6	Byte 7	Byte 8	Byte 9	Byte 10	Byte 11	Byte 12	Byte 13	...	Byte 16
Transaction identifier		Protocol identifier		Field length		Unit identifier	Function code	Register address		Word count		Byte count	RF Tag communications conditions setting information		
X	X	0000 hex		000B hex		FF hex	10 hex	B100 hex		0002 hex		04 hex			

Byte 13	Byte 14	Byte 15	Byte 16
Communications speed		Write verification	

Parameter	Description	
Register address	The register address (B100 hex) that specifies the RF Tag communications conditions.	
Word count	The number of words in the RF Tag communications conditions setting information (0002 hex)	
Byte count	The number of bytes in the RF Tag communications conditions setting information (04 hex)	
Tag communications conditions setting information	Communications speed	Specify the communications speed in 4-digit hexadecimal. High speed: 0000 hex (default), Standard: 0001 hex
	Write verification	Specify in 4-digit hexadecimal whether to perform write verification. No: 0000 hex, Yes: 0001 hex (default)

■ Response Format

Normal Response

Byte 0	Byte 1	Byte 2	Byte 3	Byte 4	Byte 5	Byte 6	Byte 7	Byte 8	Byte 9	Byte 10	Byte 11
Transaction identifier		Protocol identifier		Field length		Unit identifier	Function code	Register address		Word count	
X	X	0000 hex		0006 hex		FF hex	10 hex	B100 hex		0002 hex	

Parameter	Description
Register address	Contains the register address that was specified in the query.
Word count	Contains the word count that was specified in the query.

Error Response

Byte 0	Byte 1	Byte 2	Byte 3	Byte 4	Byte 5	Byte 6	Byte 7	Byte 8
Transaction identifier		Protocol identifier		Field length		Unit identifier	Function code	Exception code
X	X	0000 hex		0003 hex		FF hex	90 hex	

Parameter	Description
Exception code	For details, refer to <i>Exception Code Table</i> in this section.  p.65

■ Execution Example

Setting the Standard Speed and Disabling Write Verification

TX: 0000000000BFF10B10000020400010000

RX: 000000000006FF10B1000002

■ GET TAG COMMUNICATIONS CONDITIONS

The query reads the conditions that are set in the Reader/Writer for communications with RF Tags (high speed/normal speed and write verification).

■ Query Format

Byte 0	Byte 1	Byte 2	Byte 3	Byte 4	Byte 5	Byte 6	Byte 7	Byte 8	Byte 9	Byte 10	Byte 11
Transaction identifier		Protocol identifier		Field length		Unit identifier	Function code	Register address		Word count	
X	X	0000 hex		0006 hex		FF hex	03 hex	B100 hex		0002 hex	

Parameter	Description
Register address	The register address (B100 hex) that specifies the RF Tag communications conditions.
Word count	The number of words in the RF Tag communications conditions information to read (0002 hex)

■ Response Format

Normal Response

Byte 0	Byte 1	Byte 2	Byte 3	Byte 4	Byte 5	Byte 6	Byte -7	Byte 8	Byte 13	...	Byte 16
Transaction identifier		Protocol identifier		Field length		Unit identifier	Function code	Byte count	RF Tag communications conditions information		
X	X	0000 hex		0007 hex		FF hex	03 hex	04 hex			

Byte 13	Byte 14	Byte 15	Byte 16
Communications speed		Write verification	

Parameter	Description	
Byte count	The number of bytes in the RF Tag communications conditions information (04 hex)	
Tag communications conditions information	Communications speed	High speed: 0000 hex, Standard: 0001 hex
	Write verification	No: 0000 hex, Yes: 0001 hex

Error Response

Byte 0	Byte 1	Byte 2	Byte 3	Byte 4	Byte 5	Byte 6	Byte 7	Byte 8
Transaction identifier		Protocol identifier		Field length		Unit identifier	Function code	Exception code
X	X	0000 hex		0003 hex		FF hex	83 hex	

Parameter	Description
Exception code	For details, refer to <i>Exception Code Table</i> in this section.  p.65

■ Execution Example

Reading the RF Tag Communications Conditions When the Tag Communications Is Set to High Speed and Write Verification Is Disabled

TX: 000000000006FF03B1000002

RX: 000000000007FF030400010000

■ SET TCP/IP COMMUNICATIONS CONDITIONS

This query sets the TCP/IP communications conditions of the Reader/Writer.

■ Query Format

Byte 0	Byte 1	Byte 2	Byte 3	Byte 4	Byte 5	Byte 6	Byte 7	Byte 8	Byte 9	Byte 10	Byte 11	Byte 12	Byte 13	...	Byte 24
Transaction identifier		Protocol identifier		Field length		Unit identifier	Function code	Register address		Word count		Byte count	TCP/IP communications conditions		
X	X	0000 hex		0013 hex		FF hex	10 hex	B800 hex		0006 hex		0C hex	12 bytes		

Byte 13	Byte 14	Byte 15	Byte 16	Byte 17	Byte 18	Byte 19	Byte 20	Byte 21	Byte 22	Byte 23	Byte 24
IP address				Subnet mask				Gateway address			

Parameter	Description	
Register address	The register address (B800 hex) that specifies the TCP/IP communications conditions.	
Word count	The number of words in the TCP/IP communications conditions (0006 hex)	
Byte count	The number of bytes in the TCP/IP communications conditions (0C hex)	
TCP/IP communications conditions	IP address	Specify in 8-digit hexadecimal the IP address to set. Setting range: 00000000 to FFFFFFFF hex Example: C0A801C8 hex (192.168.1.200)
	Subnet mask	Specify in 8-digit hexadecimal the subnet mask to set. Setting range: FF000000 to FFFFFFFF hex Example: FFFF FF00 hex (255.255.255.0)
	Gateway address	Specify in 8-digit hexadecimal the gateway address to set. Setting range: 00000000 to FFFFFFFF hex Example: C0A80101 hex (192.168.1.1)

■ Response Format

Normal Response

Byte 0	Byte 1	Byte 2	Byte 3	Byte 4	Byte 5	Byte 6	Byte 7	Byte 8	Byte 9	Byte 10	Byte 11
Transaction identifier		Protocol identifier		Field length		Unit identifier	Function code	Register address		Word count	
X	X	0000 hex		0006 hex		FF hex	10 hex	B800 hex		0006 hex	

Parameter	Description
Register address	Contains the register address that was specified in the query.
Word count	Contains the word count that was specified in the query.

Error Response

Byte 0	Byte 1	Byte 2	Byte 3	Byte 4	Byte 5	Byte 6	Byte 7	Byte 8
Transaction identifier		Protocol identifier		Field length		Unit identifier	Function code	Exception code
X	X	0000 hex		0003 hex		FF hex	90 hex	

Parameter	Description
Exception code	For details, refer to <i>Exception Code Table</i> in this section.  p.65

■ Execution Example

Setting the IP Address to 192.168.1.200, the Subnet Mask to 255.255.255.0, and the Gateway Address to 192.168.1.1

TX: 00000000013FF10B80000060CC0A801C8FFFFFF00C0A80101

RX: 000000000006FF10B8000006

■ GET TCP/IP COMMUNICATIONS CONDITIONS

This query reads the TCP/IP information that is set in the Reader/Writer.

■ Query Format

Byte 0	Byte 1	Byte 2	Byte 3	Byte 4	Byte 5	Byte 6	Byte 7	Byte 8	Byte 9	Byte 10	Byte 11
Transaction identifier		Protocol identifier		Field length		Unit identifier	Function code	Register address		Word count	
X	X	0000 hex		0006 hex		FF hex	03 hex	B800 hex		0006 hex	

Parameter	Description
Register address	The register address (B800 hex) that specifies the TCP/IP communications conditions.
Word count	The number of words in the TCP/IP communications conditions information to read (0006 hex)

■ Response Format

Normal Response

Byte 0	Byte 1	Byte 2	Byte 3	Byte 4	Byte 5	Byte 6	Byte 7	Byte 8	Byte 9	...	Byte 20
Transaction identifier		Protocol identifier		Field length		Unit identifier	Function code	Byte count	TCP/IP communications conditions		
X	X	0000 hex		0013 hex		FF hex	03 hex	0C hex	12 bytes		

Byte 9	Byte 10	Byte 11	Byte 12	Byte 13	Byte 14	Byte 15	Byte 16	Byte 17	Byte 18	Byte 19	Byte 20
IP address				Subnet mask				Gateway address			

Parameter	Description	
Byte count	The number of bytes in the TCP/IP communications conditions that was read (0C hex)	
TCP/IP communications conditions	IP address	Contains the IP address that was read in 8-digits hexadecimal. Example: C0A801C8 hex (192.168.1.200)
	Subnet mask	Contains the subnet mask that was read in 8-digits hexadecimal. Example: FFFF FF00 hex (255.255.255.0)
	Gateway address	Contains the gateway address that was read in 8-digits hexadecimal. Example: C0A80101 hex (192.168.1.1)

Error Response

Byte 0	Byte 1	Byte 2	Byte 3	Byte 4	Byte 5	Byte 6	Byte 7	Byte 8
Transaction identifier		Protocol identifier		Field length		Unit identifier	Function code	Exception code
X	X	0000 hex		0003 hex		FF hex	83 hex	

Parameter	Description
Exception code	For details, refer to <i>Exception Code Table</i> in this section.  p.65

■ Execution Example

Reading the TCP/IP Communications Conditions When the IP Address Is 192.168.1.200, the Subnet Mask Is 255.255.255.0, and the Gateway Address Is 192.168.1.1

TX: 000000000006FF03B8000006

RX: 00000000000FFF030CC0A801C8FFFFFF00C0A80101

■ SET DEVICE NAME

This query sets a name for the Reader/Writer.

■ Query Format

Byte 0	Byte 1	Byte 2	Byte 3	Byte 4	Byte 5	Byte 6	Byte 7	Byte 8	Byte 9	Byte 10	Byte 11	Byte 12	Byte 13	...	Byte 76
Transaction identifier		Protocol identifier		Field length		Unit identifier	Function code	Register address		Word count		Number of bytes in device name		Device name	
X	X	0000 hex		0047 hex		FF hex	10 hex	B900 hex		0020 hex		40 hex		64 bytes	

Parameter	Description
Register address	The register address (B900 hex) that specifies the device name.
Word count	The number of words in the device name (0020 hex)
Number of bytes in device name	The number of bytes in the device name (40 hex)
Device name	Specify the device name with up to 64 bytes of ASCII characters (up to 63 ASCII characters plus the end code (00 hex)). If there are fewer than 63 characters, fill the remaining bytes with 00 hex. You can specify ASCII characters 20 hex (space) to 7E hex (~).

■ Response Format

Normal Response

Byte 0	Byte 1	Byte 2	Byte 3	Byte 4	Byte 5	Byte 6	Byte 7	Byte 8	Byte 9	Byte 10	Byte 11
Transaction identifier		Protocol identifier		Field length		Unit identifier	Function code	Register address		Word count	
X	X	0000 hex		0006 hex		FF hex	10 hex	B900 hex		0020 hex	

Parameter	Description
Register address	Contains the register address that was specified in the query.
Word count	Contains the word count that was specified in the query.

Error Response

Byte 0	Byte 1	Byte 2	Byte 3	Byte 4	Byte 5	Byte 6	Byte 7	Byte 8
Transaction identifier		Protocol identifier		Field length		Unit identifier	Function code	Exception code
X	X	0000 hex		0003 hex		FF hex	90 hex	

Parameter	Description
Exception code	For details, refer to <i>Exception Code Table</i> in this section.  p.65

■ Execution Example

Setting the Device Name to V680S-A001

TX: 000000000047FF10B90000204056363830532A413030310000000000...00

RX: 000000000006FF10B9000020

■ GET DEVICE NAME

This query reads the name that is set in the Reader/Writer.

■ Query Format

Byte 0	Byte 1	Byte 2	Byte 3	Byte 4	Byte 5	Byte 6	Byte 7	Byte 8	Byte 9	Byte 10	Byte 11
Transaction identifier		Protocol identifier		Field length		Unit identifier	Function code	Register address		Word count	
X	X	0000 hex		0006 hex		FF hex	03 hex	B900 hex		0020 hex	

Parameter	Description
Register address	The register address (B900 hex) that specifies the device name.
Word count	The number of words in the device name to read (0020 hex)

■ Response Format

Normal Response

Byte 0	Byte 1	Byte 2	Byte 3	Byte 4	Byte 5	Byte 6	Byte 7	Byte 8	Byte 9	...	Byte 72
Transaction identifier		Protocol identifier		Field length		Unit identifier	Function code	Byte count	Device name		
X	X	0000 hex		0047 hex		FF hex	03 hex	40 hex	64 bytes		

Parameter	Description
Byte count	The number of words in the device name that was read (40 hex)
Device name	The device name that was read is given with up to 64 bytes of ASCII characters (up to 63 ASCII characters plus the end code (00 hex)) If there are fewer than 63 characters, the remaining bytes are filled with 00 hex. The device name is given with ASCII characters 20 hex (space) to 7E hex (~).

Error Response

Byte 0	Byte 1	Byte 2	Byte 3	Byte 4	Byte 5	Byte 6	Byte 7	Byte 8
Transaction identifier		Protocol identifier		Field length		Unit identifier	Function code	Exception code
X	X	0000 hex		0003 hex		FF hex	83 hex	

Parameter	Description
Exception code	For details, refer to <i>Exception Code Table</i> in this section.  p.65

■ Execution Example

Reading the Device Name When It Is Set to V680S-A001

TX:000000000006FF03B9000020

RX:000000000043FF034056363830532A413030310000000000...00

■ SET WEB COMMUNICATIONS CONDITIONS

This query sets the TCP/IP communications conditions of the Reader/Writer.

■ Query Format

Byte 0	Byte 1	Byte 2	Byte 3	Byte 4	Byte 5	Byte 6	Byte 7	Byte 8	Byte 9	Byte 10	Byte 11	Byte 12	Byte 13	Byte 14
Transaction identifier		Protocol identifier		Field length		Unit identifier	Function code	Register address		Word count		Byte count	WEB communications conditions	
X	X	0000 hex		0009 hex		FF hex	10 hex	BA00 hex		0001 hex		02 hex	2 bytes	

Parameter	Description
Register address	The register address (BA00 hex) that specifies the WEB communications conditions.
Word count	The number of words in the WEB communications conditions (0001 hex)
Byte count	The number of bytes in the WEB communications conditions (02 hex)
WEB communications conditions	Specify in 4-digit hexadecimal the Web Port to set. Setting range: 0400 to FFFF hex Example: 1BB2 hex (7090)

■ Response Format

Normal Response

Byte 0	Byte 1	Byte 2	Byte 3	Byte 4	Byte 5	Byte 6	Byte 7	Byte 8	Byte 9	Byte 10	Byte 11
Transaction identifier		Protocol identifier		Field length		Unit identifier	Function code	Register address		Word count	
X	X	0000 hex		0006 hex		FF hex	10 hex	BA00 hex		0002 hex	

Parameter	Description
Register address	Contains the register address that was specified in the query.
Word count	Contains the word count that was specified in the query.

Error Response

Byte 0	Byte 1	Byte 2	Byte 3	Byte 4	Byte 5	Byte 6	Byte 7	Byte 8
Transaction identifier		Protocol identifier		Field length		Unit identifier	Function code	Exception code
X	X	0000 hex		0003 hex		FF hex	90 hex	

Parameter	Description
Exception code	For details, refer to <i>Exception Code Table</i> in this section.  p.65

■ Execution Example

Setting the Web Port to 7090(1BB2 hex)

TX: 0000000009FF10BA000001021BB2

RX: 00000000006FF10BA000001

■ GET WEB COMMUNICATIONS CONDITIONS

This query reads the WEB information that is set in the Reader/Writer.

■ Query Format

Byte 0	Byte 1	Byte 2	Byte 3	Byte 4	Byte 5	Byte 6	Byte 7	Byte 8	Byte 9	Byte 10	Byte 11
Transaction identifier		Protocol identifier		Field length		Unit identifier	Function code	Register address		Word count	
X	X	0000 hex		0006 hex		FF hex	03 hex	BA00 hex		0001 hex	

Parameter	Description
Register address	The register address (B800 hex) that specifies the WEB communications conditions.
Word count	The number of words in the WEB communications conditions information to read (0001 hex)

■ Response Format

Normal Response

Byte 0	Byte 1	Byte 2	Byte 3	Byte 4	Byte 5	Byte 6	Byte 7	Byte 8	Byte 9	Byte 10
Transaction identifier		Protocol identifier		Field length		Unit identifier	Function code	Byte count	WEB communications conditions	
X	X	0000 hex		000F hex		FF hex	03 hex	02 hex	2 bytes	

Parameter	Description
Byte count	The number of bytes in the WEB communications conditions that was read (02 hex)
WEB communications conditions	Contains the Web Port that was read in 4-digits hexadecimal. Example: 1BB2 hex (7090)

Error Response

Byte 0	Byte 1	Byte 2	Byte 3	Byte 4	Byte 5	Byte 6	Byte 7	Byte 8
Transaction identifier		Protocol identifier		Field length		Unit identifier	Function code	Exception code
X	X	0000 hex		0003 hex		FF hex	83 hex	

Parameter	Description
Exception code	For details, refer to <i>Exception Code Table</i> in this section.  p.65

■ Execution Example

Reading the WEB Communications Conditions When the Web Port Is 7090(1BB2 hex)

TX: 000000000006FF03BA000001

RX: 000000000005FF03021BB2

■ SET WEB PASSWORD

This query sets or clears a password for accessing the Reader/Writer from a Web browser.

■ Query Format

Byte 0	Byte 1	Byte 2	Byte 3	Byte 4	Byte 5	Byte 6	Byte 7	Byte 8	Byte 9	Byte 10	Byte 11	Byte 12	Byte 13	...	Byte 76
Transaction identifier		Protocol identifier		Field length		Unit identifier	Function code	Register address		Word count		Byte count	Web Password		
X	X	0000 hex		0017 hex		FF hex	10 hex	BB00 hex		0008 hex		10 hex	16 bytes		

Parameter	Description
Register address	The register address (BB00 hex) that specifies the Web password
Word count	The number of words in the Web password (0008 hex)
Byte count	The number of bytes in the Web password (10 hex)
WEB password	Specify the Web password with up to 16 bytes of ASCII characters (up to 15 ASCII characters plus the end code (00 hex)). If there are fewer than 15 characters, fill the remaining bytes with 00 hex. You can specify ASCII characters 20 hex (space) to 7E hex (~).

■ Response Format

Normal Response

Byte 0	Byte 1	Byte 2	Byte 3	Byte 4	Byte 5	Byte 6	Byte 7	Byte 8	Byte 9	Byte 10	Byte 11
Transaction identifier		Protocol identifier		Field length		Unit identifier	Function code	Register address		Word count	
X	X	0000 hex		0006 hex		FF hex	10 hex	BB00 hex		0008 hex	

Parameter	Description
Register address	Contains the register address that was specified in the query.
Word count	Contains the word count that was specified in the query.

Error Response

Byte 0	Byte 1	Byte 2	Byte 3	Byte 4	Byte 5	Byte 6	Byte 7	Byte 8
Transaction identifier		Protocol identifier		Field length		Unit identifier	Function code	Exception code
X	X	0000 hex		0003 hex		FF hex	90 hex	

Parameter	Description
Exception code	For details, refer to <i>Exception Code Table</i> in this section.  p.65

■ Execution Example

Setting the Web Password to “password”

TX: 00000000017FF10BB0000081070617373776F72640000000000000000

RX: 000000000006FF10BB000008

■ GET WEB PASSWORD

This query reads the Web server password that is set in the Reader/Writer.

■ Query Format

Byte 0	Byte 1	Byte 2	Byte 3	Byte 4	Byte 5	Byte 6	Byte 7	Byte 8	Byte 9	Byte 10	Byte 11
Transaction identifier		Protocol identifier		Field length		Unit identifier	Function code	Register address		Word count	
X	X	0000 hex		0006 hex		FF hex	03 hex	BB00 hex		0008 hex	

Parameter	Description
Register address	The register address (BB00 hex) that specifies the Web password
Word count	The number of words in the Web password to read (0008 hex)

■ Response Format

Normal Response

Byte 0	Byte 1	Byte 2	Byte 3	Byte 4	Byte 5	Byte 6	Byte 7	Byte 8	Byte 9	...	Byte 24
Transaction identifier		Protocol identifier		Field length		Unit identifier	Function code	Byte count	Device name		
X	X	0000 hex		0013 hex		FF hex	03 hex	10 hex	16 bytes		

Parameter	Description
Byte count	The number of bytes in the Web password that was read (10 hex)
Device name	The Web password that was read is given with up to 16 bytes of ASCII characters (up to 15 ASCII characters plus the end code (00 hex)). If there are fewer than 15 characters, the remaining bytes are filled with 00 hex. The Web password is given with ASCII characters 20 hex (space) to 7E hex (~).

Error Response

Byte 0	Byte 1	Byte 2	Byte 3	Byte 4	Byte 5	Byte 6	Byte 7	Byte 8
Transaction identifier		Protocol identifier		Field length		Unit identifier	Function code	Exception code
X	X	0000 hex		0003 hex		FF hex	83 hex	

Parameter	Description
Exception code	For details, refer to <i>Exception Code Table</i> in this section.  p.65

■ Execution Example

Reading the Web Password When It Is Set to "password"

TX: 000000000006FF03BB000008

RX: 000000000013FF031070617373776F72640000000000000000

■ **INITIALIZE SETTINGS**

This query returns all of the setting information in the Reader/Writer to the default status.

■ **Query Format**

Byte 0	Byte 1	Byte 2	Byte 3	Byte 4	Byte 5	Byte 6	Byte 7	Byte 8	Byte 9	Byte 10	Byte 11	Byte 12	Byte 13	Byte 14
Transaction identifier		Protocol identifier		Field length		Unit identifier	Function code	Register address		Word count		Byte count	Option	
X	X	0000 hex		0009 hex		FF hex	10 hex	BF00 hex		0001 hex		02 hex	0000 hex	

Parameter	Description
Register address	The register address (BF00 hex) that specifies initializing settings.
Word count	The number of words for the option (0001 hex)
Byte count	The number of bytes for the option (02 hex)
Option	Always 0000 hex.

■ **Response Format**

Normal Response

Byte 0	Byte 1	Byte 2	Byte 3	Byte 4	Byte 5	Byte 6	Byte 7	Byte 8	Byte 9	Byte 10	Byte 11
Transaction identifier		Protocol identifier		Field length		Unit identifier	Function code	Register address		Word count	
X	X	0000 hex		0006 hex		FF hex	10 hex	BF00 hex		0001 hex	

Parameter	Description
Register address	Contains the register address that was specified in the query.
Word count	Contains the word count that was specified in the query.

Error Response

Byte 0	Byte 1	Byte 2	Byte 3	Byte 4	Byte 5	Byte 6	Byte 7	Byte 8
Transaction identifier		Protocol identifier		Field length		Unit identifier	Function code	Exception code
X	X	0000 hex		0003 hex		FF hex	83 hex	

Parameter	Description
Exception code	For details, refer to <i>Exception Code Table</i> in this section.  p.65

■ **Execution Example**

Initializing All Settings

TX: 000000000009FF10BF000001020000

RX: 000000000006FF10BF000001

Checking Reader/Writer Information

MEASURE NOISE

Measures the noise level around the Reader/Writer.

Query Format

Byte 0	Byte 1	Byte 2	Byte 3	Byte 4	Byte 5	Byte 6	Byte 7	Byte 8	Byte 9	Byte 10	Byte 11
Transaction identifier		Protocol identifier		Field length		Unit identifier	Function code	Register address		Word count	
X	X	0000 hex		0006 hex		FF hex	03 hex	D200 hex		0003 hex	

Parameter	Description
Register address	The register address for noise measurement (D200 hex)
Word count	The number of words in the noise information to read (0003 hex)

Response Format

Normal Response

Byte 0	Byte 1	Byte 2	Byte 3	Byte 4	Byte 5	Byte 6	Byte 7	Byte 8	Byte 9	...	Byte 14
Transaction identifier		Protocol identifier		Field length		Unit identifier	Function code	Byte count	Noise information		
X	X	0000 hex		0009 hex		FF hex	03 hex	06 hex			

Byte 9	Byte 10	Byte 11	Byte 12	Byte 13	Byte 14
Average		Maximum		Minimum	

Parameter	Description	
Byte count	The number of bytes in the Reader/Writer operating status that was read (04 hex)	
Noise information	Average	Contains the average noise that was read in 4-digits hexadecimal. 0000 to 0063 hex (0 to 99)
	Maximum	Contains the maximum noise that was read in 4-digits hexadecimal. 0000 to 0063 hex (0 to 99)
	Minimum	Contains the minimum noise that was read in 4-digits hexadecimal. 0000 to 0063 hex (0 to 99)

Error Response

Byte 0	Byte 1	Byte 2	Byte 3	Byte 4	Byte 5	Byte 6	Byte 7	Byte 8
Transaction identifier		Protocol identifier		Field length		Unit identifier	Function code	Exception code
X	X	0000 hex		0003 hex		FF hex	83 hex	

Parameter	Description
Exception code	For details, refer to <i>Exception Code Table</i> in this section.  p.65

Execution Example

Measuring the Noise When the Average Is 51, the Maximum Is 62, and the Minimum Is 43

TX:000000000006FF03D2000003

RX:000000000009FF03060033003E002B

■ GET Model INFORMATION

This query reads the model number from the Reader/Writer.

■ Query Format

Byte 0	Byte 1	Byte 2	Byte 3	Byte 4	Byte 5	Byte 6	Byte 7	Byte 8	Byte 9	Byte 10	Byte 11
Transaction identifier		Protocol identifier		Field length		Unit identifier	Function code	Register address		Word count	
X	X	0000 hex		0006 hex		FF hex	03 hex	C100 hex		0010 hex	

Parameter	Description
Register address	The register address (C100 hex) that specifies the model number information.
Word count	The number of words in the model number information to read (0010 hex)

■ Response Format

Normal Response

Byte 0	Byte 1	Byte 2	Byte 3	Byte 4	Byte 5	Byte 6	Byte 7	Byte 8	Byte 9	...	Byte 40
Transaction identifier		Protocol identifier		Field length		Unit identifier	Function code	Byte count	Model number information		
X	X	0000 hex		0023 hex		FF hex	03 hex	20 hex			

Parameter	Description
Byte count	The number of bytes in the model number information that was read (20 hex)
Model number information	The model number is returned as a 31-character ASCII text string. If there are fewer than 32 characters, the remaining bytes are filled with 00 hex.

Error Response

Byte 0	Byte 1	Byte 2	Byte 3	Byte 4	Byte 5	Byte 6	Byte 7	Byte 8
Transaction identifier		Protocol identifier		Field length		Unit identifier	Function code	Exception code
X	X	0000 hex		0003 hex		FF hex	83 hex	

Parameter	Description
Exception code	For details, refer to <i>Exception Code Table</i> in this section.  p.65

■ Execution Example

Reading the Model Information When the Model Number Is V680S-A001

TX: 000000000006FF03C1000010

RX: 000000000023FF032056363830532A41303031000

■ GET FIRMWARE VERSION

The query reads the firmware version from the Reader/Writer.

■ Query Format

Byte 0	Byte 1	Byte 2	Byte 3	Byte 4	Byte 5	Byte 6	Byte 7	Byte 8	Byte 9	Byte 10	Byte 11
Transaction identifier		Protocol identifier		Field length		Unit identifier	Function code	Register address		Word count	
X	X	0000 hex		0006 hex		FF hex	03 hex	C000 hex		0006 hex	

Parameter	Description
Register address	The register address (C000 hex) that specifies the firmware version.
Word count	The number of words in the firmware version information to read (0006 hex)

■ Response Format

Normal Response

Byte 0	Byte 1	Byte 2	Byte 3	Byte 4	Byte -5	Byte 6	Byte 7	Byte 8	Byte 9	...	Byte 20
Transaction identifier		Protocol identifier		Field length		Unit identifier	Function code	Byte count	Firmware version information		
X	X	0000 hex		000F hex		FF hex	03 hex	0C hex			

Byte 9	Byte 10	Byte 11	Byte 12	Byte 13	Byte 14	Byte 15	Byte 16	Byte 17	Byte 18	Byte 19	Byte 20
Major version of Run Mode program		Minor version of Run Mode program		Revision of Run Mode program		Major version of Safe Mode program		Minor version of Safe Mode program		Revision of Safe Mode program	

Parameter	Description	
Byte count	The number of bytes in the firmware version information (0C hex)	
Firmware version information	Major version of Run Mode program	0000 to 0099 hex (BCD)
	Minor version of Run Mode program	0000 to 0099 hex (BCD)
	Revision of Run Mode program	0000 to 9999 hex (BCD)
	Major version of Safe Mode program	0000 to 0099 hex (BCD)
	Minor version of Safe Mode program	0000 to 0099 hex (BCD)
	Revision of Safe Mode program	0000 to 9999 hex (BCD)

Error Response

Byte 0	Byte 1	Byte 2	Byte 3	Byte 4	Byte 5	Byte 6	Byte 7	Byte 8
Transaction identifier		Protocol identifier		Field length		Unit identifier	Function code	Exception code
X	X	0000 hex		0003 hex		FF hex	83 hex	

Parameter	Description
Exception code	For details, refer to <i>Exception Code Table</i> in this section.  p.65

■ Execution Example

Reading the Firmware Version Information when the Run Program Version Is 1.2.3 and the Safe Program Version Is 1.2.2

TX: 000000000006FF03C0000006

RX: 0000000000FFF030C000100020003000100020002

■ GET MAC ADDRESS

This query reads the MAC address from the Reader/Writer.

■ Query Format

Byte 0	Byte 1	Byte 2	Byte 3	Byte 4	Byte 5	Byte 6	Byte 7	Byte 8	Byte 9	Byte 10	Byte 11
Transaction identifier		Protocol identifier		Field length		Unit identifier	Function code	Register address		Word count	
X	X	0000 hex		0006 hex		FF hex	03 hex	C200 hex		0003 hex	

Parameter	Description
Register address	The register address (C200 hex) that specifies the MAC address.
Word count	The number of words in the MAC address to read (0003 hex)

■ Response Format

Normal Response

Byte 0	Byte 1	Byte 2	Byte 3	Byte 4	Byte 5	Byte 6	Byte 7	Byte 8	Byte 9	...	Byte 14
Transaction identifier		Protocol identifier		Field length		Unit identifier	Function code	Byte count	MAC address		
X	X	0000 hex		0009 hex		FF hex	03 hex	06 hex			

Parameter	Description
Byte count	The number of bytes in the MAC address that was read (06 hex)
MAC address	MAC address: 0000 0000 0000 to FFFF FFFF FFFF hex

Error Response

Byte 0	Byte 1	Byte 2	Byte 3	Byte 4	Byte 5	Byte 6	Byte 7	Byte 8
Transaction identifier		Protocol identifier		Field length		Unit identifier	Function code	Exception code
X	X	0000 hex		0003 hex		FF hex	83 hex	

Parameter	Description
Exception code	For details, refer to <i>Exception Code Table</i> in this section.  p.65

■ Execution Example

Reading the MAC Address When It Is 11-22-33-44-55-66

TX: 000000000006FF03C2000003

RX: 000000000009FF0306112233445566

■ GET Reader/Writer OPERATING STATUS

This query reads the operating status from the Reader/Writer.

■ Query Format

Byte 0	Byte 1	Byte 2	Byte 3	Byte 4	Byte 5	Byte 6	Byte 7	Byte 8	Byte 9	Byte 10	Byte 11
Transaction identifier		Protocol identifier		Field length		Unit identifier	Function code	Register address		Word count	
X	X	0000 hex		0006 hex		FF hex	03 hex	C300 hex		0002 hex	

Parameter	Description
Register address	The register address (C300 hex) that specifies the Reader/Writer operating status.
Word count	The number of words in the Reader/Writer operating status to read (0002 hex)

■ Response Format

Normal Response

Byte 0	Byte 1	Byte 2	Byte 3	Byte 4	Byte 5	Byte 6	Byte 7	Byte 8	Byte 9	...	Byte 12
Transaction identifier		Protocol identifier		Field length		Unit identifier	Function code	Byte count	Reader/Writer operating status		
X	X	0000 hex		0007 hex		FF hex	03 hex	04 hex			

Byte 9	Byte 10	Byte 11	Byte 12
Mode		Status information	

Parameter	Description	
Byte count	The number of bytes in the Reader/Writer operating status that was read (04 hex)	
Reader/Writer operating status	Mode	Contains the mode of the Reader/Writer that was read in 4-digits hexadecimal. 0000 hex: Safe Mode 0001 hex: Run Mode
	Status information	Contains the status of the Reader/Writer that was read in 4-digits hexadecimal. 0000 hex: Initializing 0001 hex: Idling 0002 hex: RF Tag communications in progress 0003 hex: Downloading 0004 hex: Error

Error Response

Byte 0	Byte 1	Byte 2	Byte 3	Byte 4	Byte 5	Byte 6	Byte 7	Byte 8
Transaction identifier		Protocol identifier		Field length		Unit identifier	Function code	Exception code
X	X	0000 hex		0003 hex		FF hex	83 hex	

Parameter	Description
Exception code	For details, refer to <i>Exception Code Table</i> in this section.  p.65

■ Execution Example

Reading Status When the Reader/Writer Is in Run Mode and Idling

TX: 000000000006FF03C3000002

RX: 000000000007FF030400010001

■ GET OPERATING TIME

This query reads the operating time from when the power supply to the Reader/Writer was turned ON.

■ Query Format

Byte 0	Byte 1	Byte 2	Byte 3	Byte 4	Byte 5	Byte 6	Byte 7	Byte 8	Byte 9	Byte 10	Byte 11
Transaction identifier		Protocol identifier		Field length		Unit identifier	Function code	Register address		Word count	
X	X	0000 hex		0006 hex		FF hex	03 hex	C400 hex		0002 hex	

Parameter	Description
Register address	The register address (C400 hex) that specifies the operating time.
Word count	The number of words in the operating time to read (0002 hex)

■ Response Format

Normal Response

Byte 0	Byte 1	Byte 2	Byte 3	Byte 4	Byte 5	Byte 6	Byte 7	Byte 8	Byte 9	Byte 10	Byte 11	Byte 12
Transaction identifier		Protocol identifier		Field length		Unit identifier	Function code	Byte count	Operating time			
X	X	0000 hex		0007 hex		FF hex	03 hex	04 hex	32 bits			

Parameter	Description
Byte count	The number of bytes in the operating time that was read (04 hex)
Operating time	The operating time from when the Reader/Writer was started in 8-digits hexadecimal (Unit: ms)

Error Response

Byte 0	Byte 1	Byte 2	Byte 3	Byte 4	Byte 5	Byte 6	Byte 7	Byte 8
Transaction identifier		Protocol identifier		Field length		Unit identifier	Function code	Exception code
X	X	0000 hex		0003 hex		FF hex	83 hex	

Parameter	Description
Exception code	For details, refer to <i>Exception Code Table</i> in this section.  p.65

■ Execution Example

Reading the Operating Time When It Is 1234567890

TX: 000000000006FF03C4000002

RX: 000000000007FF0304499602D2

■ GET RECENT ERROR QUERY INFORMATION

This query reads the recent error information from the Reader/Writer.

■ Query Format

Byte 0	Byte 1	Byte 2	Byte 3	Byte 4	Byte 5	Byte 6	Byte 7	Byte 8	Byte 9	Byte 10	Byte 11
Transaction identifier		Protocol identifier		Field length		Unit identifier	Function code	Register address		Word count	
X	X	0000 hex		0006 hex		FF hex	03 hex	C700 hex		007D hex	



Parameter	Description
Register address	The register address (C700 hex) that specifies the recent error query information.
Word count	The number of words in the recent error query information to read (007D hex)

■ Response Format

Normal Response

Byte 0	Byte 1	Byte 2	Byte 3	Byte 4	Byte 5	Byte 6	Byte 7	Byte 8	Byte 9	...	Byte 258
Transaction identifier		Protocol identifier		Field length		Unit identifier	Function code	Byte count	Recent error query information		
X	X	0000 hex		00FF hex		FF hex	03 hex	FA hex	250 bytes		

Byte 9	Byte 10	Byte 11	Byte 12	Byte 13	Byte 14	Byte 15	Byte 16	Byte 17	Byte 18	Byte 19	Byte 20	Byte 21	Byte 22	Byte 23	...	Byte 258
Operating time				IP address of remote node				Error code				Exception code	Communications query information size	Communications query information		
236 bytes																

Parameter	Description	
Byte count	The number of bytes in the recent error query information that was read (FA hex)	
Recent error query information	Operating time	The operating time from when the Reader/Writer was started in 8-digits hexadecimal (Unit: ms)
	IP address of remote node	Contains the IP address that was read in 8-digits hexadecimal. Example: C0A801C8 hex (192.168.1.200)
	Error code	For details, refer to <i>Error Codes</i> in this section.  p.66
	Exception code	For details, refer to <i>Exception Code Table</i> in this section.  p.65
	Communications query information size	Contains the number of bytes in the communications query information in 2-digit hexadecimal.
	Communications query information	Query that was invoked when an error occurred.

Error Response

Byte 0	Byte 1	Byte 2	Byte 3	Byte 4	Byte 5	Byte 6	Byte 7	Byte 8
Transaction identifier		Protocol identifier		Field length		Unit identifier	Function code	Exception code
X	X	0000 hex		0003 hex		FF hex	83 hex	

Parameter	Description
Exception code	For details, refer to <i>Exception Code Table</i> in this section.  p.65

▪ **Execution Example**

Reading the Recent Error Information When a Query from a Remote Node with an IP Address of 192.168.1.2 Resulted in an Error at an Operating Time of 1111111111

TX: 00000000006FF03C700007D

RX: 000000000FDFF03FA423A35C7C0A80102eeeeeeeexllccccccc...ccc

(eeeeeee: end code, xx: exception code, ll: communications query information size, ccccccc: communications query information)

■ GET COMMUNICATIONS ERROR LOG

This query reads the log of communications errors that have occurred in the Reader/Writer.

■ Query Format

Byte 0	Byte 1	Byte 2	Byte 3	Byte 4	Byte 5	Byte 6	Byte 7	Byte 8	Byte 9	Byte 10	Byte 11
Transaction identifier		Protocol identifier		Field length		Unit identifier	Function code	Register address		Word count	
X	X	0000 hex		0006 hex		FF hex	03 hex	C600 hex		0061 hex	



Parameter	Description
Register address	The register address (C600 hex) that specifies the communications error log information.
Word count	The number of words in the communications error log information to read (0061 hex)

■ Response Format

Normal Response

Byte 0	Byte 1	Byte 2	Byte 3	Byte 4	Byte 5	Byte 6	Byte 7	Byte 8	Byte 9	Byte 10	Byte 11	...	Byte 31	...	Byte 179	...	Byte 202
Transaction identifier		Protocol identifier		Field length		Unit identifier	Function code	Byte count	Number of records	Most recent communications error record		...	Most recent communications error record 7				
X	X	0000 hex		00C5 hex		FF hex	03 hex	C2 hex	1 word	10 words		...	10 words				

Byte 11	...	Byte 14	Byte 15	...	Byte 18	Byte 19	Byte 20	Byte 21	Byte 22	Byte 23	Byte 24	Byte 25	Byte 26	Byte 27	Byte 28	Byte 29	Byte 30	Byte 31	...	Byte 34
Operating time		IP address of remote node			Transaction identifier	Reserved 1		Function code	Reserved 2	Register address	Exception code	Reserved 3			End code					
4 bytes		4 bytes			2 bytes	2 bytes		1 byte	00 hex	2 bytes		3 bytes			4 bytes					

Parameter	Description	
Number of bytes in recent error query information	The number of bytes in the recent error query information that was read (FA hex)	
Number of record	The number of record in the recent error query information that was read.	
Most recent communications error record	Operating time	The operating time from when the Reader/Writer was started in 8-digits hexadecimal (Unit: ms)
	IP address of remote node	Contains the IP address where the error occurred in 4-digits hexadecimal. Example: C0A801C8 hex (192.168.1.200)
	Transaction identifier	Transaction identifier specified by the query when an error occurred.
	Reserved 1	This field is always 0000 hex.
	Function code	Function code specified by the query when an error occurred.
	Reserved 2	This field is always 00 hex.
	Register address	Register address specified by the query when an error occurred.
	Exception code	For details, refer to <i>Exception Code Table</i> in this section.  p.65
Reserved 3	Always 000000 hex.	
End code	For details, refer to <i>End Codes</i> in this section.  p.65	

Error Response

Byte 0	Byte 1	Byte 2	Byte 3	Byte 4	Byte 5	Byte 6	Byte 7	Byte 8
Transaction identifier		Protocol identifier		Field length		Unit identifier	Function code	Exception code
X	X	0000 hex		0003 hex		FF hex	83 hex	

Parameter	Description
Exception code	For details, refer to <i>Exception Code Table</i> in this section.  p.65

▪ **Execution Example**

Reading the Communications Error Log When a Communications Error Occurred at the Remote Node with IP Address 192.168.1.2 at an Operating Time of 1111111111 and a Communications Error Occurred at the Remote Node with IP Address 192.168.1.3 at an Operating Time of 2222222222

TX: 00000000006FF03C6000061

RX: 0000000000A5FF03A20002423A35C7C0A80102ccccccrrrrrr84746B8EC0A80103ccccccrrrrrr00000000...00
(ccccccc: communications query information, rrrrrrr: communications response information)

■ GET RESTORE INFORMATION

This query reads the restore information from the Reader/Writer.

■ Query Format

Byte 0	Byte 1	Byte 2	Byte 3	Byte 4	Byte 5	Byte 6	Byte 7	Byte 8	Byte 9	Byte 10	Byte 11
Transaction identifier		Protocol identifier		Field length		Unit identifier	Function code	Register address		Word count	
X	X	0000 hex		0006 hex		FF hex	03 hex	C800 hex		0061 hex	

Parameter	Description
Register address	The register address (C800 hex) that specifies the restore information.
Word count	The number of words in the restore information to read (0061 hex)

■ Response Format

Normal Response

Byte 0	Byte 1	Byte 2	Byte 3	Byte 4	Byte 5	Byte 6	Byte 7	Byte 8	Byte 9	...	Byte 34	...	Byte 179	...	Byte 202
Transaction identifier		Protocol identifier		Field length		Unit identifier	Function code	Byte count	Most restore information record		...	Most restore information record 7			
X	X	0000 hex		00C5 hex		FF hex	03 hex	C2 hex	12 words		...	12 words			

Byte 9	Byte 10	Byte 11	...	Byte 14	Byte 15	...	Byte 22	Byte 23	Byte 24	Byte 25	Byte 26	Byte 27	...	Byte 34
Number of records		Operating time			UID			User address		Data size		Data		
1 word		2 words			4 words			1 word		1 word		4 words		

Parameter	Description						
Byte count	The number of bytes in the restore information that was read (C2 hex)						
Number of records	The number of record in the restore information that was read.						
Most restore information record	<table border="1"> <tr> <td>Operating time</td> <td rowspan="5">If all restore information does not exist, it is 0000 hex.</td> </tr> <tr> <td>UID(8 bytes)</td> </tr> <tr> <td>User address</td> </tr> <tr> <td>Data size</td> </tr> <tr> <td>Data(8 bytes)</td> </tr> </table>	Operating time	If all restore information does not exist, it is 0000 hex.	UID(8 bytes)	User address	Data size	Data(8 bytes)
Operating time	If all restore information does not exist, it is 0000 hex.						
UID(8 bytes)							
User address							
Data size							
Data(8 bytes)							
Most restore information record 1	Same as above						
:	:						
Most restore information record 7	Same as above						

Error Response

Byte 0	Byte 1	Byte 2	Byte 3	Byte 4	Byte 5	Byte 6	Byte 7	Byte 8
Transaction identifier		Protocol identifier		Field length		Unit identifier	Function code	Exception code
X	X	0000 hex		0003 hex		FF hex	83 hex	

Parameter	Description
Exception code	For details, refer to <i>Exception Code Table</i> in this section.  p.65

■ Execution Example

If the operating time is writing data to the RF tag failure occurs while 1111111111 to restore it.
(In the case of failure of the block end partial write)

TX: 000000000006FF03C8000061

RX: 0000000000C5FF03C2*****

Controlling Reader/Writer Operation

■ STOP

This query stops Reader/Writer operation.

■ Query Format

Byte 0	Byte 1	Byte 2	Byte 3	Byte 4	Byte 5	Byte 6	Byte 7	Byte 8	Byte 9	Byte 10	Byte 11	Byte 12	Byte 13	Byte 14
Transaction identifier		Protocol identifier		Field length		Unit identifier	Function code	Register address		Word count		Byte count	Option	
X	X	0000 hex		0009 hex		FF hex	10 hex	D100 hex		0001 hex		02 hex	0000 hex	

Parameter	Description
Register address	The register address (D100 hex) that specifies the stop setting
Word count	The number of words for the option (0001 hex)
Byte count	The number of bytes for the option (02 hex)
Option	Always 0000 hex.

■ Response Format

Normal Response

Byte 0	Byte 1	Byte 2	Byte 3	Byte 4	Byte 5	Byte 6	Byte 7	Byte 8	Byte 9	Byte 10	Byte 11
Transaction identifier		Protocol identifier		Field length		Unit identifier	Function code	Register address		Word count	
X	X	0000 hex		0006 hex		FF hex	10 hex	D100 hex		0001 hex	

Parameter	Description
Register address	Contains the register address that was specified in the query.
Word count	Contains the word count that was specified in the query.

Error Response

Byte 0	Byte 1	Byte 2	Byte 3	Byte 4	Byte 5	Byte 6	Byte 7	Byte 8
Transaction identifier		Protocol identifier		Field length		Unit identifier	Function code	Exception code
X	X	0000 hex		0003 hex		FF hex	83 hex	

Parameter	Description
Exception code	For details, refer to <i>Exception Code Table</i> in this section.  p.65

■ Execution Example

Stopping Communications with RF Tags

TX: 0000000009FF10D1000001020000

RX: 0000000006FF10D1000001

The response for the STOP query depends on the timing of when the query was acknowledged. Examples are provided below.

Example: Processing was canceled when a STOP query was received before the Reader/Writer detected an RF Tag.

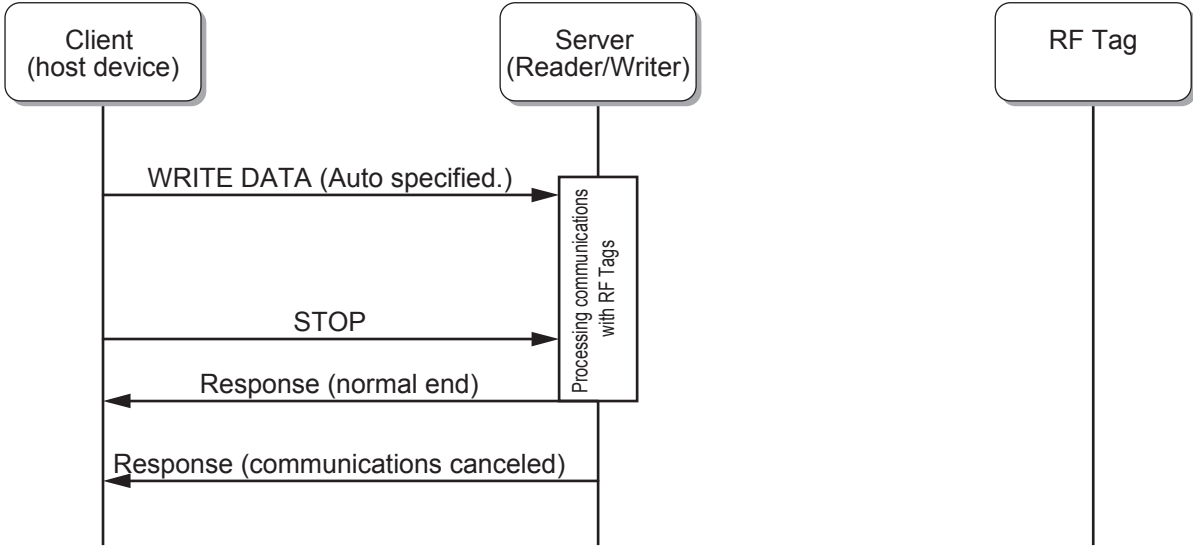

Example: Processing was aborted when a STOP query was received after the Reader/Writer detected an RF Tag but before it completed processing.

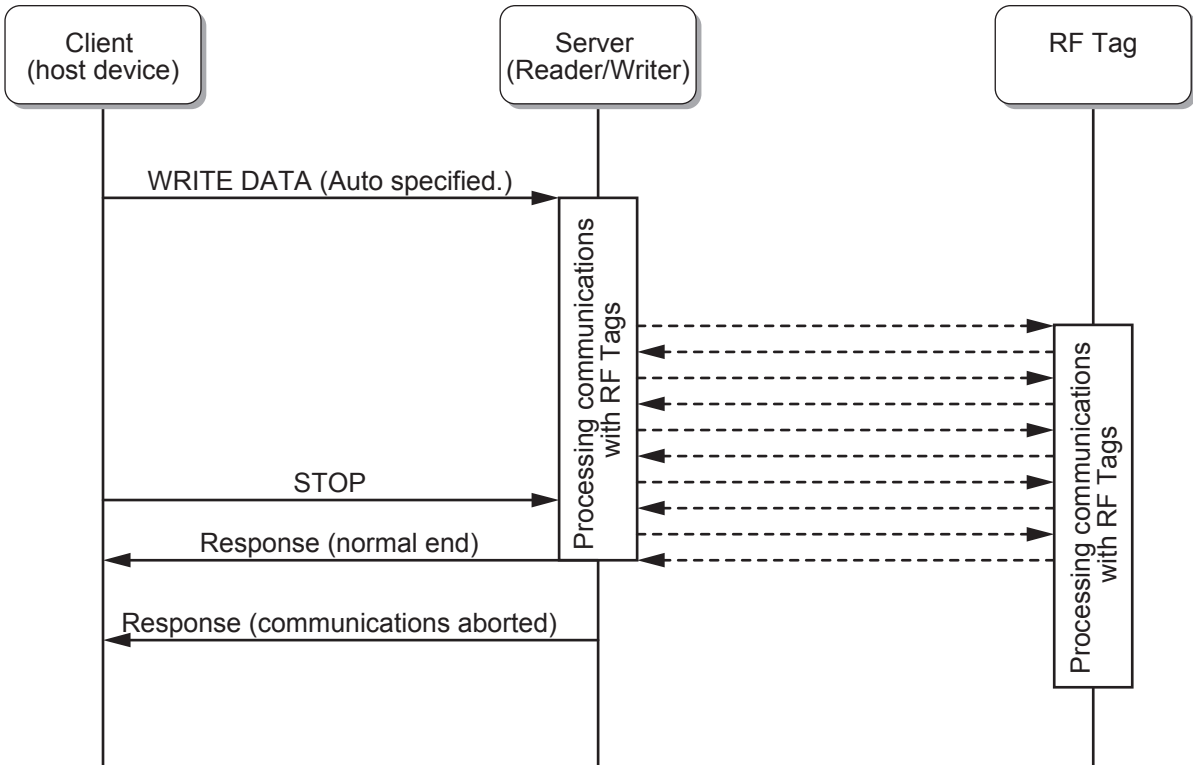

Example: Processing was aborted when a STOP query was received immediately after completing processing after the Reader/Writer detected an RF Tag.

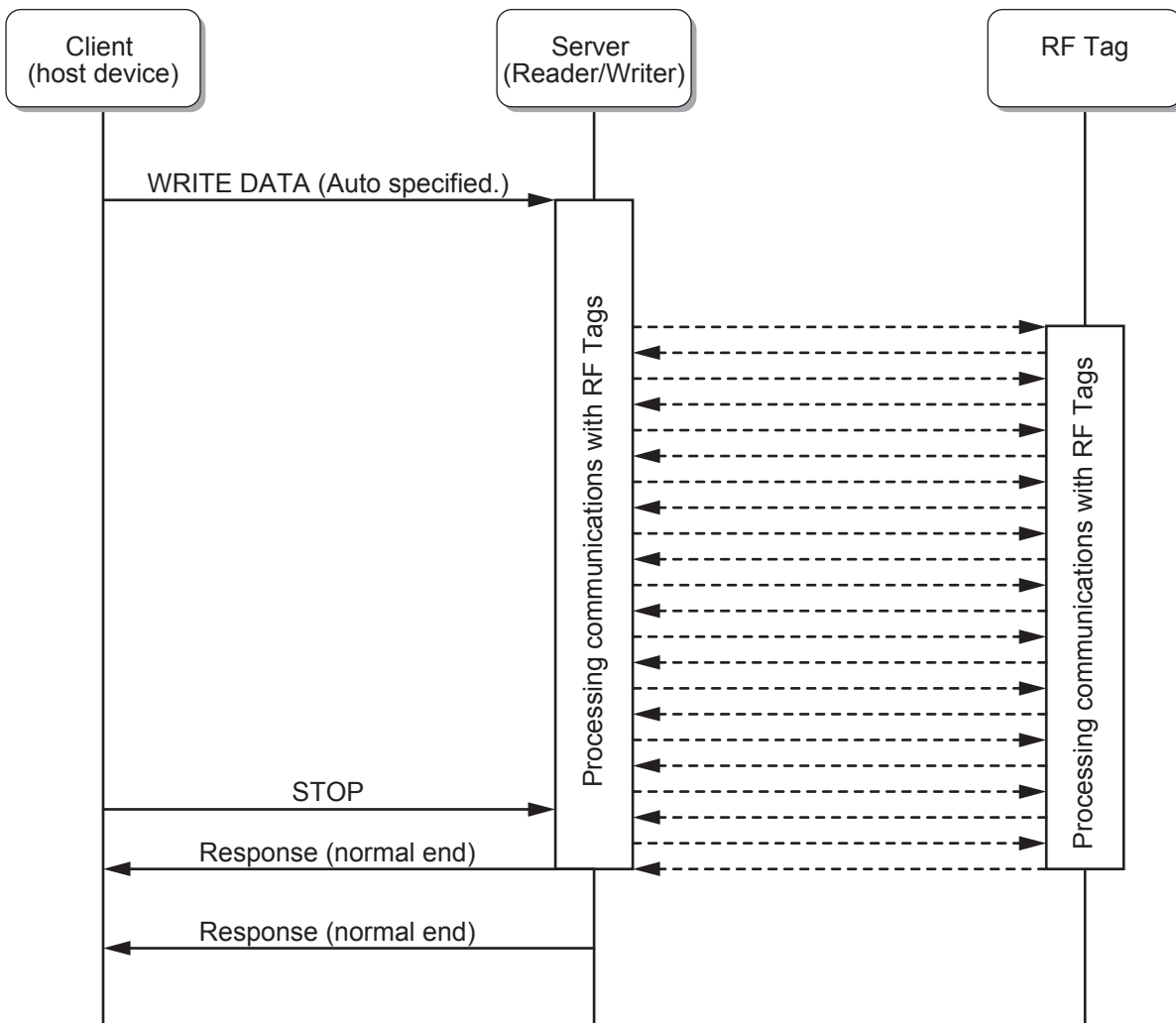

■ **RESET**

This query resets the Reader/Writer.

■ **Query Format**

Byte 0	Byte 1	Byte 2	Byte 3	Byte 4	Byte 5	Byte 6	Byte 7	Byte 8	Byte 9	Byte 10	Byte 11	Byte 12	Byte 13	Byte 14
Transaction identifier		Protocol identifier		Field length		Unit identifier	Function code	Register address		Word count		Number of bytes for option		Option
X	X	0000 hex		0009 hex		FF hex	10 hex	D000 hex		0001 hex		02 hex		

Parameter	Description
Register address	The register address (D000 hex) that specifies the reset setting
Word count	The number of words for the option (0001 hex)
Number of bytes for option	The number of bytes for the option (02 hex)
Option	0000 hex: Reboot FFFF hex: Forced reset

■ **Response Format**

Normal Response

Byte 0	Byte 1	Byte 2	Byte 3	Byte 4	Byte 5	Byte 6	Byte 7	Byte 8	Byte 9	Byte 10	Byte 11
Transaction identifier		Protocol identifier		Field length		Unit identifier	Function code	Register address		Word count	
X	X	0000 hex		0006 hex		FF hex	10 hex	D000 hex		0001 hex	

Parameter	Description
Register address	Contains the register address that was specified in the query.
Word count	Contains the word count that was specified in the query.

Note: When forced reset, the response will not be returned.

Error Response

Byte 0	Byte 1	Byte 2	Byte 3	Byte 4	Byte 5	Byte 6	Byte 7	Byte 8
Transaction identifier		Protocol identifier		Field length		Unit identifier	Function code	Exception code
X	X	0000 hex		0003 hex		FF hex	83 hex	

Parameter	Description
Exception code	For details, refer to <i>Exception Code Table</i> in this section.  p.65

■ **Execution Example**

Resetting the Reader/Writer

TX: 000000000009FF10D0000001020000

RX: 000000000006FF10D0000001

Initializing All Settings

Category	Register address	Query name	R/W
RF Tag access	0000 to 9FFF hex	DATA READ	R
	0000 to 9FFF hex	WRITE DATA	W
	A000 hex	READ ID	R
	A100 hex	DATA FILL	W
	A200 hex	LOCK	W
	A300 hex	RF TAG OVERWRITE COUNT CONTROL	W
	A400 to A700 hex	(Reserved)	---
	A800 hex	DATA COPY	W
Reader/Writer settings	B000 hex	GET TAG COMMUNICATIONS OPTION	R
	B000 hex	SET TAG COMMUNICATIONS OPTION	W
	B100 hex	GET TAG COMMUNICATIONS CONDITIONS	R
	B100 hex	SET TAG COMMUNICATIONS CONDITIONS	W
	B200 to B700 hex	(Reserved)	---
	B800 hex	GET TCP/IP COMMUNICATIONS CONDITIONS	R
	B800 hex	SET TCP/IP COMMUNICATIONS CONDITIONS	W
	B900 hex	GET DEVICE NAME	R
	B900 hex	SET DEVICE NAME	W
	BA00 hex	GET TCP/IP COMMUNICATIONS CONDITIONS	R
	BA00 hex	SET TCP/IP COMMUNICATIONS CONDITIONS	W
	BB00 hex	GET WEB PASSWORD	R
	BB00 hex	SET WEB PASSWORD	W
	BC00 to BE00 hex	(Reserved)	---
	BF00 hex	INITIALIZE SETTINGS	W
Getting Reader/Writer information	C000 hex	GET FIRMWARE VERSION	R
	C100 hex	GET DEVICE INFORMATION	R
	C200 hex	GET MAC ADDRESS	R
	C300 hex	GET Reader/Writer OPERATING STATUS	R
	C400 hex	GET OPERATING TIME	R
	C500 hex	GET SYSTEM ERROR LOG	R
	C600 hex	GET COMMUNICATIONS ERROR LOG	R
	C700 hex	GET RECENT ERROR QUERY INFORMATION	R
	C800 hex	(Reserved)	---
Controlling Reader/Writer operation	D000 hex	RESET	W
	D100 hex	STOP	W
	D200 hex	MEASURE NOISE	R

MEMO

Section 6

Browser Interface

❏ Browser Operation Window	108
❏ Operation Interface	109

Browser Operation Window

Connect the Ethernet cable and start a Web browser on the computer.

Enter the IP address of the Reader/Writer in the address field of the Web browser to display the browser operation window.

Enter `http://192.168.1.200` if you are using the default IP address.

If a Web password is not set in the Reader/Writer, the Status View will be displayed first.

To display another view, click the specified menu button.

Only one browser can connect to the Reader/Writer at one time. If another browser B connects to the Reader/Writer while browser A is displaying the Reader/Writer interface, browser A will be cut off and the Reader/Writer will communicate with browser B.

The system requirements to use the Web browser are as follows:

- Internet Explorer 7 or higher running on Windows XP or Windows 7
- JRE version 6.0 or higher

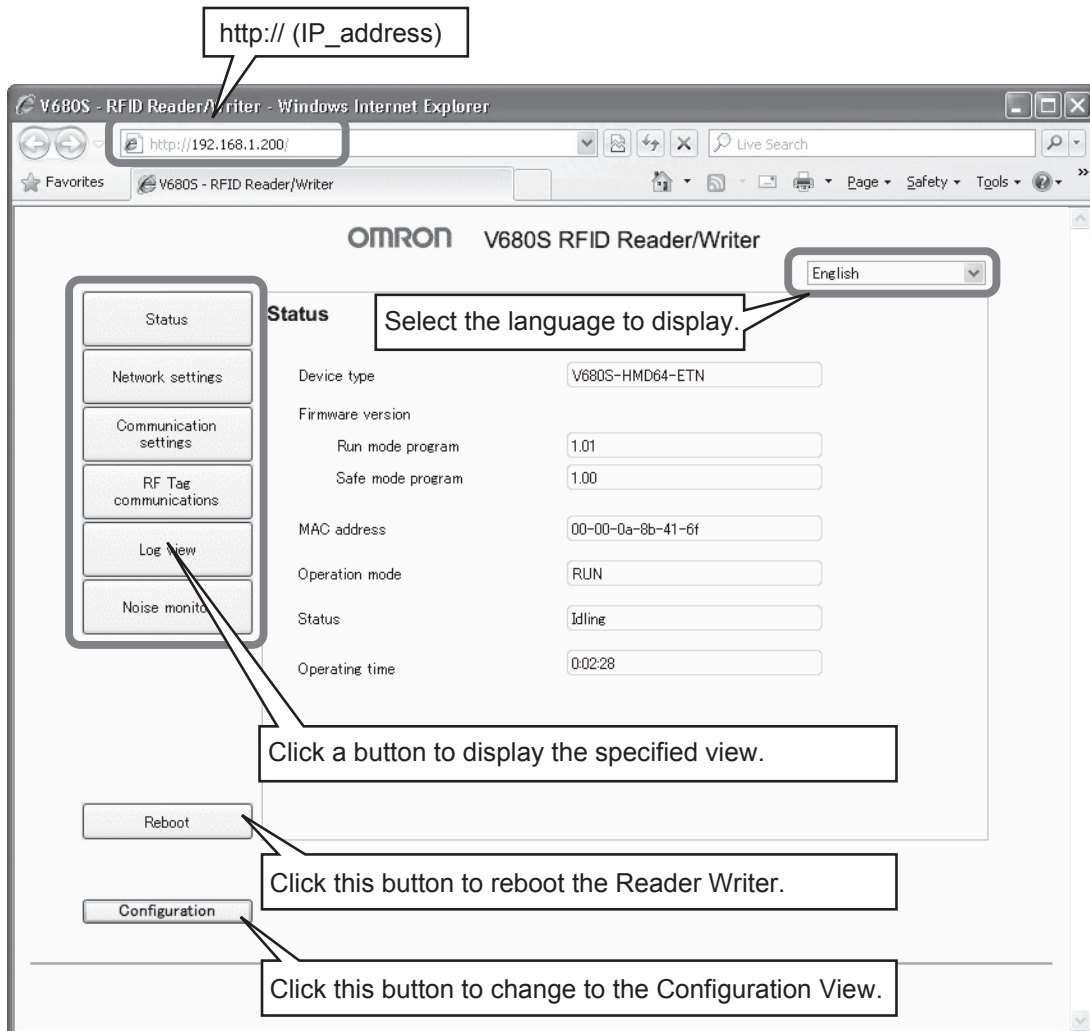

* Windows is a registered trademark of Microsoft Corporation in the USA and other countries. Screenshots are used with permission from Microsoft.

* Java software can be downloaded from the following.

URL: <http://www.java.com/en/>

Java and other trademarks that contain "Java" are the registered trademarks of Oracle Corporation or its related companies.

Operation Interface

Password Entry View

If a Web password is set in the Reader/Writer, the Password Entry View will be displayed first.

OMRON V680S RFID Reader/Writer

Password :

OK

Item name	Description
Password	If a Web password is set in the Reader/Writer, enter the password.



CHECK!

If an error message appears after pressing the OK button, please make sure the password.



CHECK!

If the Reader/Writer is running in Safe mode, the password entry screen does not appear even if you set the password.

Status View

Item name		Description
Device type		Displays the product model number.
Firmware version	Run mode program	Displays the Run Mode program versions.
	Safe mode program	Displays the Safe Mode program versions.
MAC address		Displays the MAC address from the Reader/Writer.
Operation mode		Displays the mode of the Reader/Writer. Run/Safe Mode
Status		Displays the status of the Reader/Writer. Idling/RF Tag communications in progress and Changing settings/Error
Operating time		Displays the time since the Reader/Writer was started. Example: 0:12:34

Network Settings View

Item name	Description	Setting range	Default
IP address	IP address	---	192.168.1.200
Subnet mask	Subnet mask address	---	255.255.255.0
Gateway address	Gateway address	---	192.168.1.254
Web Port	The port number used for browser communications	1024 to 65535	7090
Web password	15 ASCII characters max.	15 ASCII characters max.	None
Device name	63 ASCII characters max.	63 ASCII characters max.	None



If you change the network settings, please restart the Reader/Writer. The new settings will be effective after a restart of the Reader/Writer.



When you restart the Reader/Writer after you change the IP address, WEB browser can not reconnect to the Reader/Writer. If you re-specified the new IP address in the address field of the browser, the screen will be appeared.

Communications Settings View

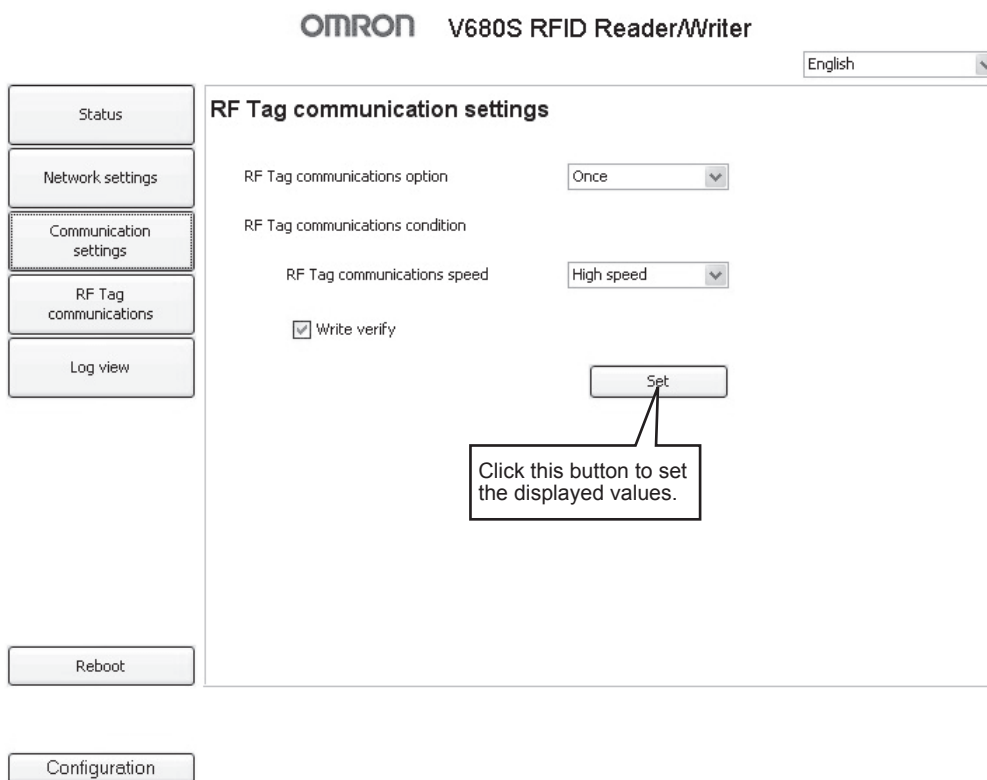

Item name	Description	Setting range	Default
RF Tag Communications option	Select the RF Tag communications option.	Once, Auto, or FIFO Trigger	Once
RF Tag Communications Speed	Specify the speed of communications with the RF Tags.	High speed or Normal speed	High speed
Write Verify	Select this check box to enable write verification.	Enabled/disabled	Enabled

 Refer to *Communications Options* in *Section 2 Names and Functions of Components* for information of RF Tag Communications option.

CHECK!  p.21

 Refer to *SET TAG COMMUNICATIONS CONDITIONS Query* in *Section 2 Names and Functions of Components* for information of RF Tag Communications option.

CHECK!  p.28

 The settings are immediately reflected when you click the "Set" button.

CHECK!

 When the Reader/Writer is running in safe mode, this screen can not be operated. Please run the Reader/Writer in RUN mode.

CHECK!

RF Tag Communications View

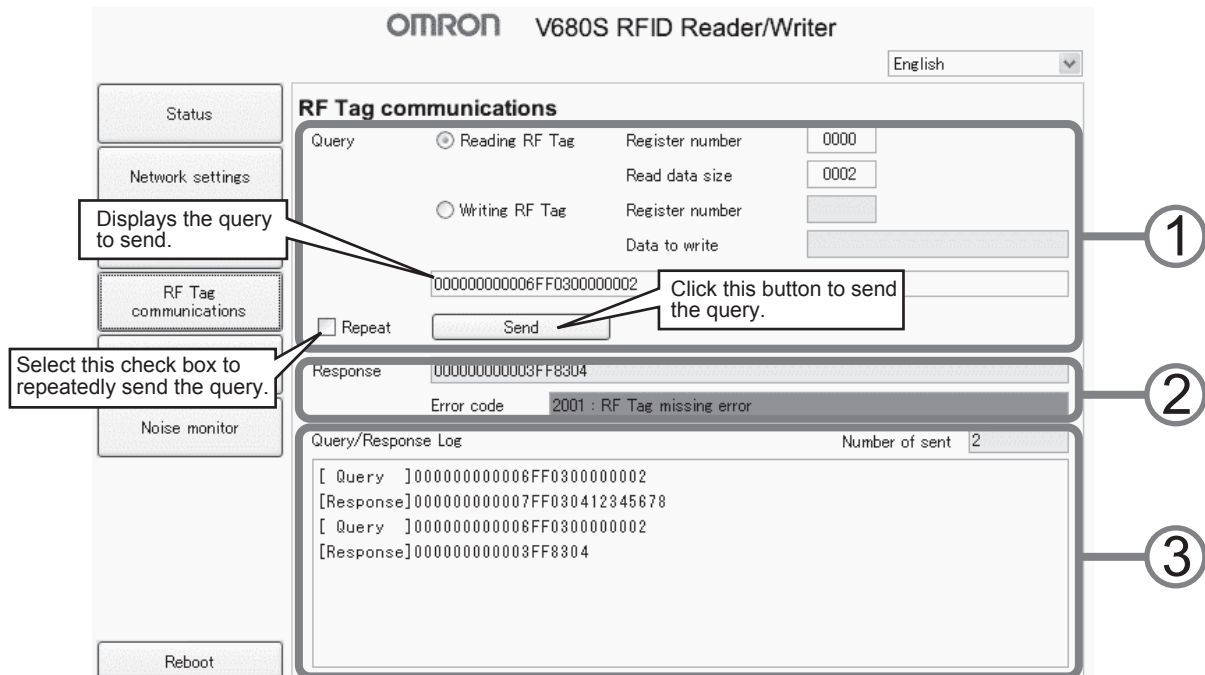

1. Query Area

Item name	Description	Setting range
Reading RF Tag	Register number	Specify in 4-digit hexadecimal the start address for reading data from the RF Tag.
	Read data size	Specify in 4-digit hexadecimal the number of words of data to read from the RF Tag.
Writing RF Tag	Register address	Specify in 4-digit hexadecimal the start address for writing data in the RF Tag.
	Data to write	Specify the data to write to the RF Tag.
Display of query to send	Displays the query to send if communications are performed with an RF Tag. Enter the query directly when you are not communicating with an RF Tag. If you enter the query directly, you cannot use a transaction identifier of FFFF hex.	---
Repeat	Select this check box to repeatedly and consecutively send the query. Clear the selection of this check box if the RF Tag communications option of the Reader/Writer is set to Auto. If a query is sent repeatedly and consecutively with the Auto option, an execution status error will occur.	---

2. Response

Item name	Description
Response	Displays the response that was returned from the Reader/Writer. The background color will be green when the operation will be done normally.
Error code	If the response from the Reader/Writer indicates an error end, the error code and a description will be displayed in red.

3. Query/Response Log

Query/Response Log Number of sent

```

[ Query ] 0000000000006FF0300000002
[Response] 0000000000007FF030412345678
[ Query ] 0000000000006FF0300000002
[Response] 0000000000003FF8304
    
```

Item name	Description
Query/Response Log	Displays up to 15 queries and responses from communications with the RF Tags. You can clear the log using right-click.
Number of sent	Displays the total number of queries send by the Reader/Writer.

Log View

OMRON V680S RFID Reader/Writer English

Log view

Recent error query information



Time	Error name	IP address	Error code	Exception code	Query size	Query
0:00:15	RF Tag missing error	192.168.1.236	20010000	04	0C	

Communications error log

Time	Error name	IP address	Transaction ID	Function code	Register address	Exception code	Error code
0:00:15	RF Tag missing error	192.168.1.236	0000	03			

System error log

Time	Error name	Error code	Information1	Information2

Item name	Description
Recent error query information	Displays the following recent error query information: Time, Error name, IP address, Error code, Exception code, Query size, and Query
Communications error log	Displays the following information from the communications error log: Time, Error name, IP address, Transaction ID, Function code, Register address, Exception code, and Error code
System error log	Displays the following information from the system error log: Time, Error name, Error code, Information 1, and Information 2  Refer to <i>Communications Error Log</i> in <i>Section 2 Names and Functions of Components</i> for information of system error log.  CHECK!  <i>p.29</i>

Noise Monitor View

You can check the graphed noise level (one second intervals) around the Reader/Writer.

Please select from the screen, the type of the RF tag you want to use, because the communication performance will be changed by the combination of the type of the RF tag to be used.

The "Normal area", "Caution area" and "Warning area" will be appeared on the screen according to the type of the RF tag to be used.

Normal area	Means the noise level that communication distance can be reduced to about less than 20%
Caution area	Means the noise level that communication distance can be reduced to about 20% to 50%.
Warning area	Means the noise level that communication distance can be reduced to about 50% or more.



About the relationship between the Reader/Writer communication performance and the noise level, please refer to *Noise monitor* in *Section 2 Names and Functions of Components*.

CHECK!



p.26



Because there is variation in the result of the noise measurement, please consider the result as a guideline.

CHECK!

OMRON V680S RFID Reader/Writer

English

Noise monitor

Peak: 86

RF Tag: V680-D1KP66T

Noise

100

75

50

25

0

Please select the type of the RF tag you want to use.

Warning area shown in white.

Caution area shown in light blue.

Normal area shown in blue.

Click this button to start monitoring noise.

Start

Stop

Click this button to stop monitoring noise.

Status

Network settings

Communication settings

RF Tag communications

Log view

Noise monitor

Reboot

Configuration

Item name	Description
Noise monitor	The display is updated every second. The maximum, average, and minimum noise levels since noise monitoring was started are displayed.

Reboot

If you click the **Reboot** Button on any of the operation views, a Confirm Reboot Dialog Box is displayed.

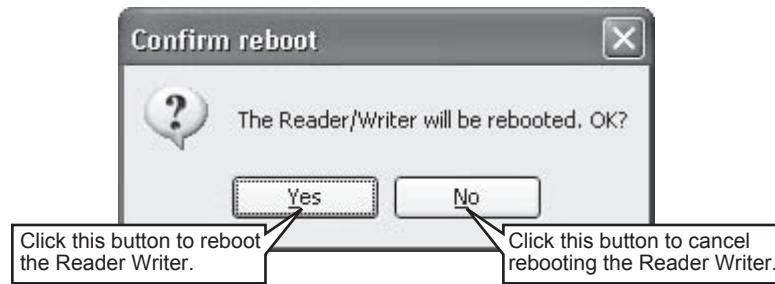

The following dialog box is displayed after the Reader/Writer has finished rebooting. Click the **Yes** Button to connect to the Reader/Writer.

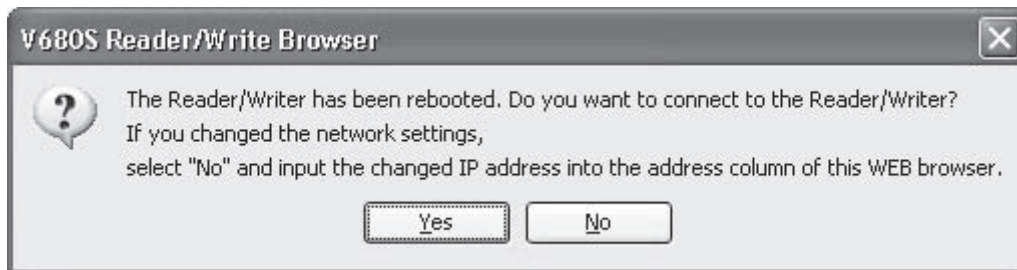

The following dialog box is displayed after reconnecting to the Reader/Writer. Click the **OK** Button.



When re-connection goes wrong and an error message is displayed, please check connection with the Reader/Writer and reboot a browser.

Configuration

You can save a configuration file (INI file) that contains the configuration information from the Reader/Writer in the computer. You can also send a configuration file to the Reader/Writer to change all of the configuration information in the Reader/Writer. Or, you can click the **Default** Button to return all of the configuration information in the Reader/Writer to the default settings.

To display the Configuration View, click the **Configuration** Button at the bottom of the browser operation window.

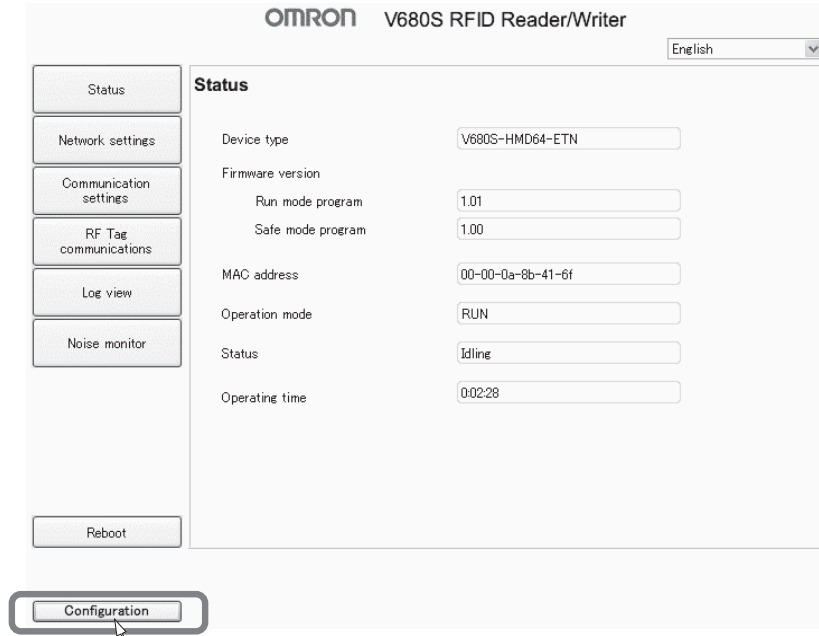

Click the **Configuration** Button at the bottom of the browser operation window to display the Configuration View.

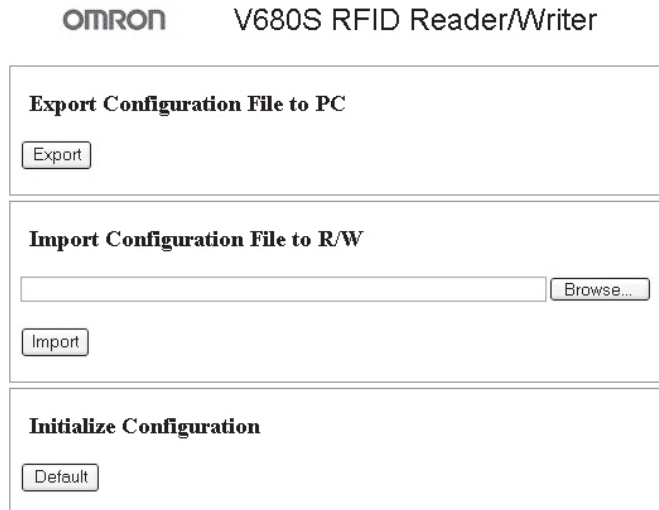

Status

Item name	Description
Export Configuration File to PC	Saves a configuration file that contains the Reader/Writer settings on the computer.
Import Configuration File to R/W	Updates the settings in the Reader/Writer with the settings in a configuration file that you select on the computer.
Initialize Configuration	Returns all of the settings in the Reader/Writer to the default settings.

■ Saving a Configuration File on the Computer

You can click the **Export** Button in the *Export Configuration File to PC* Area to save a configuration file (file name: conf.ini) that contains the configuration information from the Reader/Writer on the computer. The configuration file uses a normal INI file format.

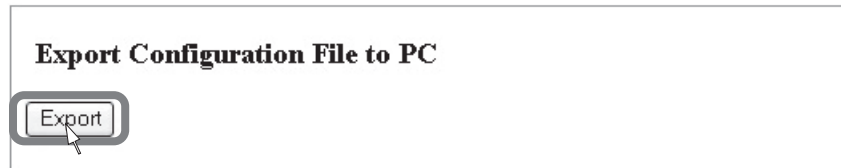

Click the **Export** Button. The following dialog box will be displayed. Click the **Save** Button.



Specify where to save the file and click the **Save** Button. The configuration information from the Reader/Writer will be saved in the configuration file.

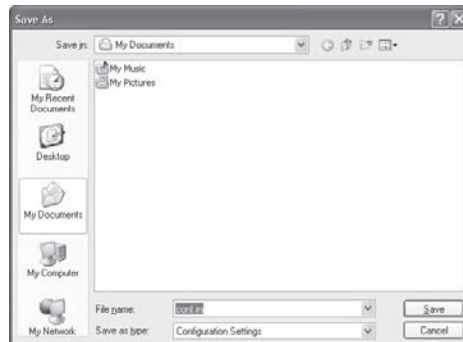

Configuration File Example

```
[NetworkSetting]
IPAddress=192.168.1.200
SubnetMask=255.255.255.0
GatewayAddress=192.168.1.254
DeviceName=
WebPassword=
WebPortNo=7090
[RFTagCommunicationSetting]
CommunicationSpeed=0
WriteVerify=1
CommunicationOption=0
```

■ Sending a Configuration File to the Reader/Writer

You can change all of the configuration information in the Reader/Writer with the following procedure: Click the **Browse** Button in the *Upload Configuration File Area*, select the configuration file to use to set up the Reader/Writer, and then click the **Import** Button.

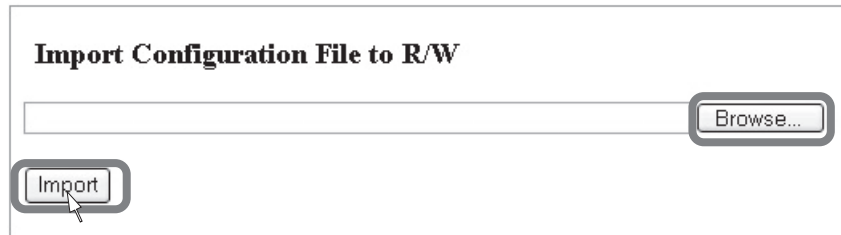

Click the **Browse** Button. A dialog box to select the configuration file will be displayed. Select the configuration file and then click the **Open** Button.

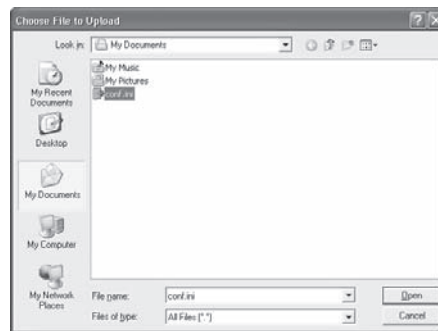

Click the **Import** Button. All of the configuration information in the Reader/Writer will be changed.

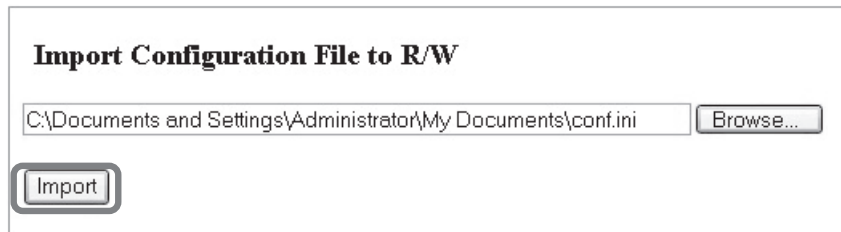

The following information is displayed after setting is completed.

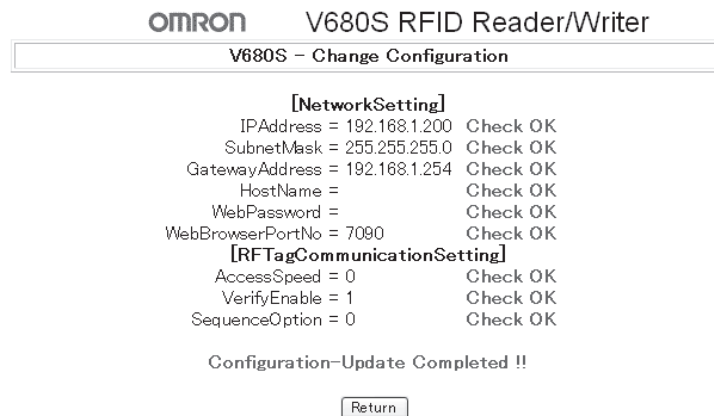

■ Initializing the Settings

Click the **Default** Button in the *Initialize Configuration Area* to return all of the settings in the Reader/Writer to the default settings. After you initialize the settings, cycle the power supply to the Reader/Writer to enable the new settings.

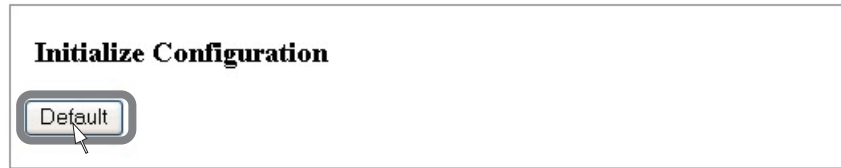

Click the **Default** Button in the *Initialize Configuration Area*. The following dialog box will be displayed. Click the **OK** Button.

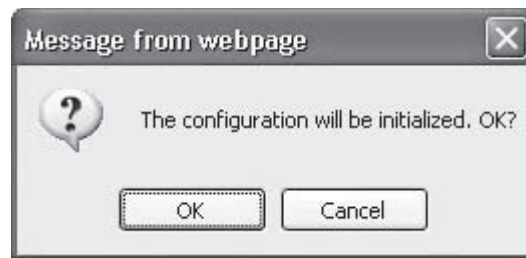

The following information is displayed after setting is completed.

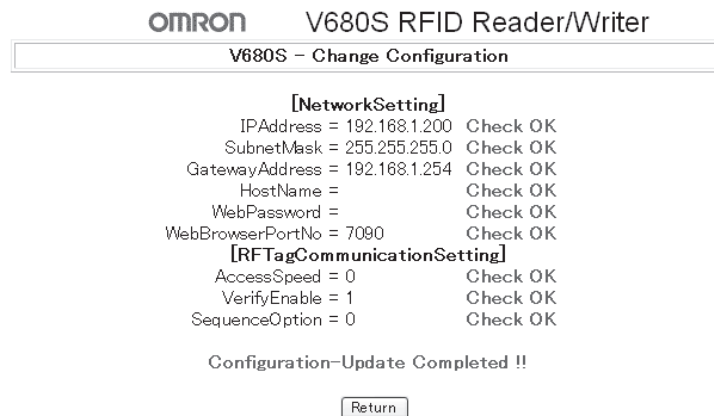

Configuration File

This section describes the format of the configuration file. The configuration file uses a normal INI file format.

- Any line that starts with a semicolon (;) is treated as a comment.
- Any line that starts with an opening bracket ([) is treated as a section declaration row. The row must also end in a closing bracket (]).
- Any row that does not start with either of the above two characters is an entry row.

Section and Entry Table

Section name	Entry name	Description	Default
NetworkSetting	IPAddress	Gives the setting of the IP address of the Reader/Writer. Specify four decimal numbers separated by periods.	192.168.1.200
	SubnetMask	Gives the setting of the subnet mask of the Reader/Writer. Specify four decimal numbers separated by periods.	255.255.255.0
	GatewayAddress	Gives the setting of the default gateway of the Reader/Writer. Specify four decimal numbers separated by periods.	192.168.1.254
	DeviceName	Gives the name of the Reader/Writer. Specify up to 63 ASCII characters.	
	WebPassword	Gives the login password for the browser interface. Specify up to 15 ASCII characters. Specify "" (blank) for no password.	
	WebPortNo	Gives the Ethernet communications port number for the browser interface. Specify 1024 to 65535 decimal.	7090
RFTagCommunicationSetting	CommunicationSpeed	Gives the communications speed between the Reader/Writer and RF Tags. Set a decimal number. 0: High speed 1: Normal speed	0
	WriteVerify	Gives the setting for write verification for write communications. Set a decimal number. 0: No verification 1: Verification	1
	CommunicationOption	Gives the setting of the RF Tag communications option. Set a decimal number. 0: Once 1: Auto 2: FIFO trigger	0

Section 7

Troubleshooting

❖ Error Descriptions	124
❖ Errors and Indicator Status	125
❖ Errors and Countermeasures	127
❖ Maintenance and Inspection	130
❖ Troubleshooting Flowcharts	131
❖ Safe Mode	136

Error Descriptions

Information on up to eight errors that occur are recorded until the power supply to the Reader/Writer is turned OFF. You can access this information from the host device or the Web server.

Fatal Errors

Reader/Writer Operation Errors

The NORM/ERR indicator in the operation indicators flashes red if the control signal is not stable or if an error occurs in user configuration memory. If the Reader/Writer detects a user configuration memory error during startup, it will start in Safe Mode and the RUN indicator will flash green.

Check the connection of the control signal or correct the user settings, and then cycle the power supply to the Reader/Writer to return to normal operation.

System Errors

The NORM/ERR indicator in the operation indicators lights red if there is a CPU error, system memory error, or hardware fault. If the Reader/Writer detects a system memory error during startup, it will start in Safe Mode and the RUN indicator will flash green.

Nonfatal Errors

The NORM/ERR indicator in the operation indicators flashes red once if an error occurs in communications between the Reader/Writer and host device or in communications with an RF Tag.

V680S-HMD64-ETN

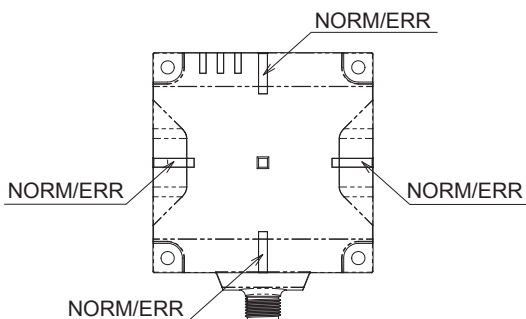

V680S-HMD66-ETN

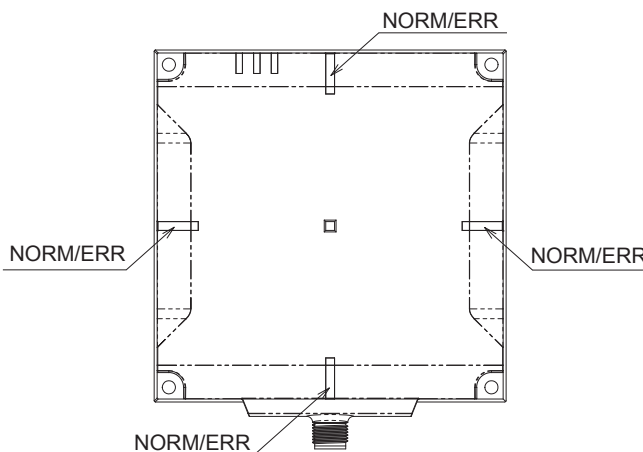





Errors and Indicator Status





Fatal Errors

Reader/Writer Operation Errors

User Configuration Memory Error



RUN	NORM/ERR	Processing when error occurs
		<p>There is an error in user configuration memory.</p> <ul style="list-style-type: none"> Initialize the settings to restore normal operation. <p> Refer to <i>User Configuration Memory Error</i> in this Section for information for Initialize the setting.</p> <p>  p.127</p>
Lit green	Flashing red	

Unstable Control Signal or User Configuration Memory (Host Device Communications Conditions Settings) Error



RUN	NORM/ERR	Processing when error occurs
		<p>The value of the control signal is not stable.</p> <ul style="list-style-type: none"> See if the control signal line in the V680S Cable is connected correctly to 24 VDC. See if there is a source of strong noise near the Reader/Writer or Cable. <p>There is an error in user configuration memory (host device communications conditions settings).</p> <ul style="list-style-type: none"> Initialize the settings to restore normal operation. <p> Refer to <i>User Configuration Memory Error</i> in this Section for information for Initialize the setting.</p> <p>  p.127</p> <p>* The Reader/Writer automatically starts in Safe Mode when it detects an error.</p>
Flashing green	Flashing red	

System Errors

CPU Error or Hardware Fault



RUN	NORM/ERR	Processing when error occurs
		<p>Please take the appropriate action referring <i>System Errors</i> in this Section</p> <p>Please replace the Reader/Writer if the condition does not change.</p> <p> p.127</p>
Lit green	Lit red	

System Memory Error

RUN	NORM/ERR	Processing when error occurs
		<p>Please take the appropriate action referring <i>System Errors</i> in this Section</p> <p>Please replace the Reader/Writer if the condition does not change.</p> <p> p.127</p> <p>* If the Reader/Writer detects a fault, the Reader/Writer will start in the "Safe mode" automatically.</p>
Flashing green	Lit red	

Nonfatal Errors



The NORM/ERR indicator flashes once if an error occurs in communications between the Reader/Writer and host device or in communications with an RF Tag.

RUN	NORM/ERR
	
Lit green	Flashes red once



If a nonfatal error occurs, the Reader/Writer will add 80 hex to the function code that was specified by the host device and set the result in the function code field in the response message. It will also set an exception code that classifies the error in the exception code field.



- Returned Function Code Example for an Error

Function code specified in query	Function code returned in response
03 hex	83 hex

 For details, refer to *Exception Code Table* in *Message Details* in *Section 5 Host Communications Specifications*.
CHECK!  p.66

After the host device detects an error, it can send a GET COMMUNICATIONS ERROR LOG query to the Reader/Writer to check the error detail information. Refer to the following tables for the error codes that indicate error detail information.

 Refer to *Error Codes* in *Message Details* in *Section 5 Host Communications Specifications* for the error codes that indicate error detail information.
CHECK!  p.66

 Refer to *GET COMMUNICATIONS ERROR LOG* in *Message Details* in *Section 5 Host Communications Specifications* for the connection procedure.
CHECK!  p.97

Errors and Countermeasures

Reader/Writer Operation Errors

■ User Configuration Memory Error

Initialize the settings to restore normal operation. There are the following two ways to initialize the Reader/Writer.

■ Initializing with a Query Message from the Host Device

You can send the INITIALIZE SETTINGS query to the Reader/Writer to return the settings to the default values. The query format is given below.

Byte 0	Byte 1	Byte 2	Byte 3	Byte 4	Byte 5	Byte 6	Byte 7	Byte 8	Byte 9	Byte 10	Byte 11	Byte 12	Byte 13	Byte 14
Transaction identifier		Protocol identifier		Field length		Unit identifier	Function code	Register address		Word count		Byte count	Option	
X	X	0000 hex		0009 hex		FF hex	10 hex	BF00 hex		0001 hex		02 hex	0000 hex	

■ Initializing through the Web Server

You can connect a computer to the network, start a Web browser, and return the settings to the default values from the Web browser window.



Refer to *Initializing the Settings in Configuration in Section 6 Browser Interface* for the procedure to Initializing through the Web Server.

CHECK!  p.121

■ Unfixed Operation Mode Error or User Configuration Memory (Host Device Communications Conditions Settings) Error

Identify the error on the Error Log View in the Web browser and restore operation with the countermeasure.



Refer to *Log View in Section 6 Browser Interface* for the procedure to check the error log contents from the Web browser window.

CHECK!  p.115

■ Unfixed Operation Mode Error

See if the control signal line in the V680S Cable is connected correctly to the 24 VDC terminal on the power source. Check for sources of noise around the Cable.

■ User Configuration Memory Error (Host Device Communications Conditions Settings)

Initialize the settings to restore normal operation. You can connect a computer to the network, start a Web browser, and return the settings to the default values from the Web browser window.



Refer to *Initializing the Settings in Configuration in Section 6 Browser Interface* for the procedure to Initializing through the Web Server.

CHECK!  p.121

System Errors

Turn OFF the power supply, check the wiring, and then turn ON the power supply. If the problem does not change, recovery is not possible for the error. Replace the Reader/Writer.





V680S Query Errors

You can send a GET COMMUNICATIONS ERROR LOG query to the Reader/Writer to check the error detail information. Refer to the following table for the error codes and countermeasures.

Error name	Error code	Countermeasure
Frame length error	1001 hex	Check the contents of the query frame and send the correct frame. Reduce the frame length.
Frame header error	1002 hex	Check the contents of the query frame and send the correct frame. Make sure the frame header is correct.
Unknown query error	1003 hex	Check the contents of the query and send the correct frame. Make sure that the value in the function code field is correct.
Query format error	1004 hex	Check the contents of the query and send the correct frame. 1. If the function code is FC3, make sure that the following fields were not omitted: Function code, register address, and number of words 2. If the function code is FC10, make sure that the following fields were not omitted: Function code, register address, number of words, and number of bytes 3. If the function code is FC10, make sure that the number of words (and number of bytes) agrees with the size of the option data.
Query parameter error	1005 hex	Check the contents of the query and send the correct frame. 1. Make sure that the value in the register address field is correct. 2. Make sure that the combination of the register address field and the number of words (and number of bytes) field is correct. 3. Make sure the value of the option data is correct.
Execution status error	1006 hex	Send the query again. Execution is not possible because the Reader/Writer is performing other processing.
Query response error	1010 hex	Reconnect to the Reader/Writer and send the query again. The response from the Reader/Writer could not be returned for some reason (TCP/IP communications were cut off, the Cable was disconnected, etc.).

RF Tag Communications Errors

You can send a GET COMMUNICATIONS ERROR LOG query to the Reader/Writer to check the error detail information. Refer to the following table for the error codes and countermeasures.

Error name	Error code	Countermeasure
RF Tag missing error	2001 hex	Change the control timing so that communications start when there is an RF Tag in the communications area of the Reader/Writer. Measure the noise and implement noise countermeasures.  p.26 Check the influence of surrounding metal and make sure there is sufficient communications distance.
RF Tag communications error	2002 hex	Change the control timing so that communications start when there is an RF Tag in the communications area of the Reader/Writer. Measure the noise and implement noise countermeasures.  p.26 Check the influence of surrounding metal and make sure there is sufficient communications distance.
UID mismatch error	2003 hex	Perform communications when the RF Tag for which data is to be restored is in the communications area of the Reader/Writer.
RF Tag address error	2004 hex	Adjust the processing area (addresses) for communications with the RF Tag to match the memory area of the RF Tag.
RF Tag lock error	2005 hex	The RF Tag memory region that contains the communications processing area (addresses) is locked. Check the communications processing area (addresses) and perform the process again or replace the RF Tag.
RF Tag verification error	2006 hex	Repeat the processing while the RF Tag is in the communications area of the Reader/Writer. Measure the noise and implement noise countermeasures.  p.26 Check the influence of surrounding metal and make sure there is sufficient communications distance.
RF Tag data lost error	2007 hex	Repeat the processing while the RF Tag is in the communications area of the Reader/Writer. Measure the noise and implement noise countermeasures.  p.26 Check the influence of surrounding metal and make sure there is sufficient communications distance.
RF Tag system error	2008 hex	Change to an RF Tag that is supported by the Reader/Writer.
RF Tag overwriting error	2009 hex	Replace the RF Tag.
Reader/Writer connection error	200A hex	Make sure that the copy destination Reader/Writer is operating normally. Make sure that the copy destination Reader/Writer is normally connected to the network and that there are no mistakes in the settings.

Maintenance and Inspection

The Reader/Writer must be inspected on a daily or periodic basis so that the functions remain in good condition. The Reader/Writer consists of semiconductors that last almost indefinitely. The following malfunctions, however, may result due to the operating environment and conditions.

- (1) Element deterioration due to overvoltage or overcurrent.
- (2) Element deterioration due to continuous stress caused by high ambient temperature.
- (3) Connector contact faults or insulation deterioration due to humidity and dust.
- (4) Connector contact faults or element corrosion due to corrosive gas.

■ Inspection Items

No.	Inspection item	Details	Criteria	Remarks
1	Power supply voltage fluctuation	(1) Make sure that the supply voltage fluctuation at the power supply terminal block is within the permissible range.	Within supply voltage specified range	Multimeter
		(2) Make sure that there are no frequent instantaneous power failures or radical voltage fluctuations.	Within permissible voltage fluctuation range	Power supply analyzer
2	Ambient environment			
	(a) Temperature	(a) Within the specified range	(a) -10 to 55°C	Maximum and minimum thermometer Hygrometer
	(b) Humidity	(b) Within the specified range	(b) 25% to 85%	
	(c) Vibration and shock	(c) Influence of vibration or shock from machines	(c) Within the specified range	
	(d) Dust	(d) Make sure that the Reader/Writer is free of accumulated dust and foreign particles.	(d) Must not be present.	
(e) Corrosive gas	(e) Make sure that no metal parts are discolored or corroded.	(e) Must not be present.		
3	Panel condition			
	(a) Ventilation	(a) Make sure that the system is ventilated properly with natural ventilation, forced ventilation, or cooling air.	(a) The interior temperature must be between -10 and 55°C with proper ventilation.	---
	(b) Damage to packing for any enclosing structure	(b) Make sure that the panel packing is properly attached with no damage.	(b) The packing must have no damage.	---
4	Mounting conditions	(1) Make sure that the Reader/Writer is securely mounted.	No loose screws	---
		(2) Make sure that each connector is fully inserted.	Each connector must be locked or securely tightened with screws.	---
		(3) Make sure that no wire is broken or nearly broken.	Must be no wire that is broken or nearly broken.	---
		(4) Make sure that the distance between the RF Tags and Reader/Writer is within the specified range.	Within the specified range	---
5	RF Tag life	Manage the number of times data is written to each RF Tag.	The maximum number of overwrites must not be exceeded	---

Troubleshooting Flowcharts

If an error occurs, fully check the whole situation, determine the relationship between the system and any other devices, and refer to the following flowcharts for the troubleshooting procedures.

Main Check Flowchart

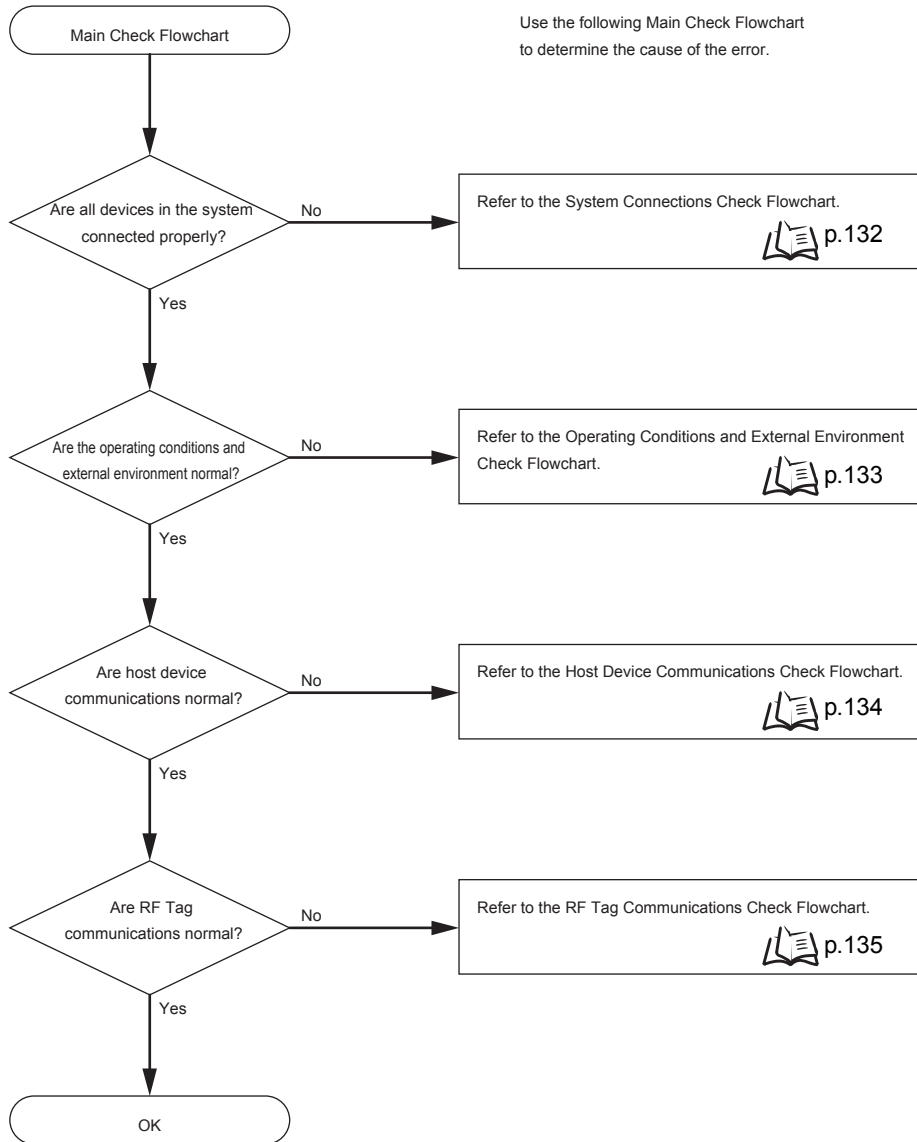

System Connections Check Flowchart

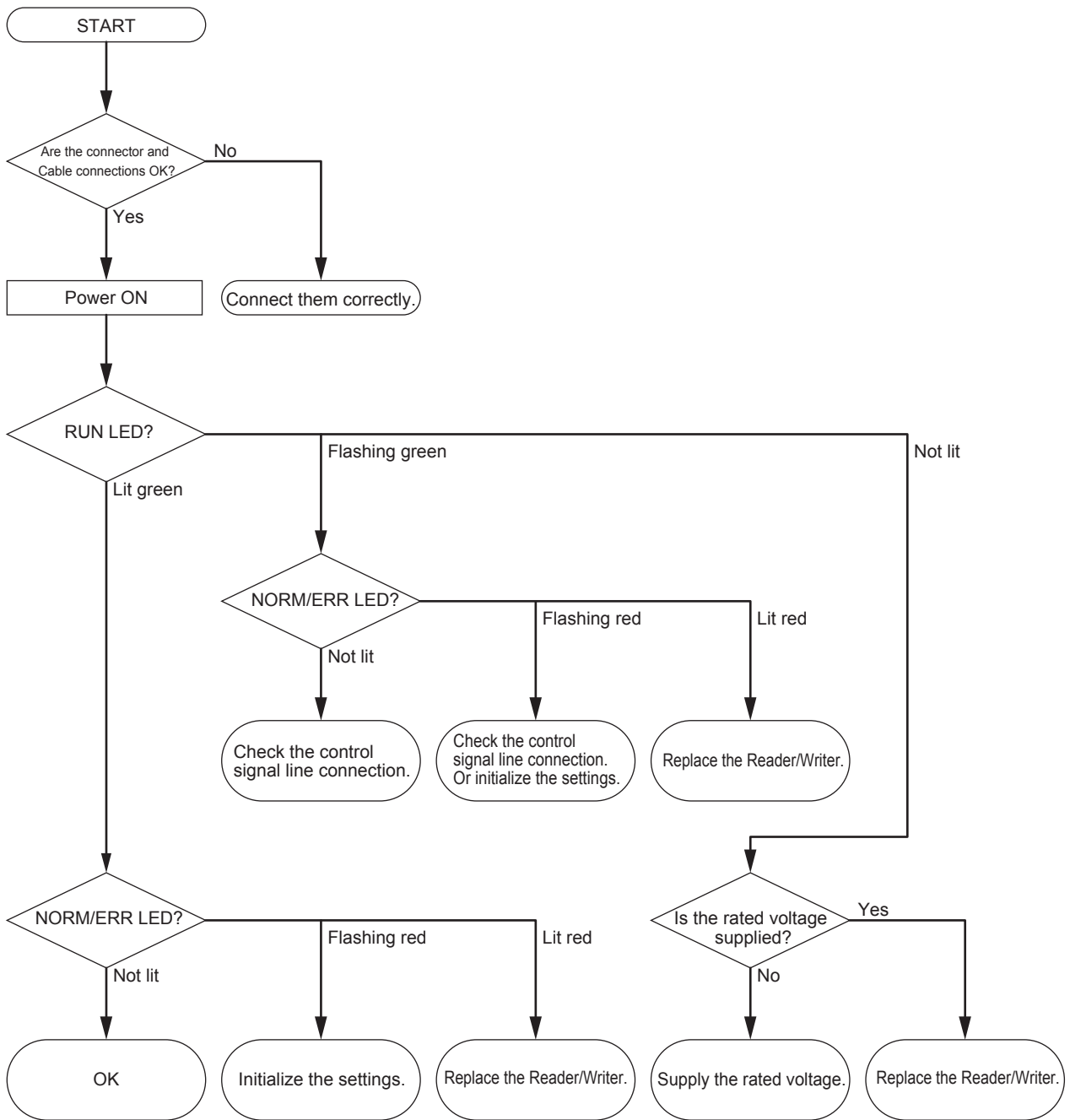

Operating Conditions and External Environment Check Flowchart

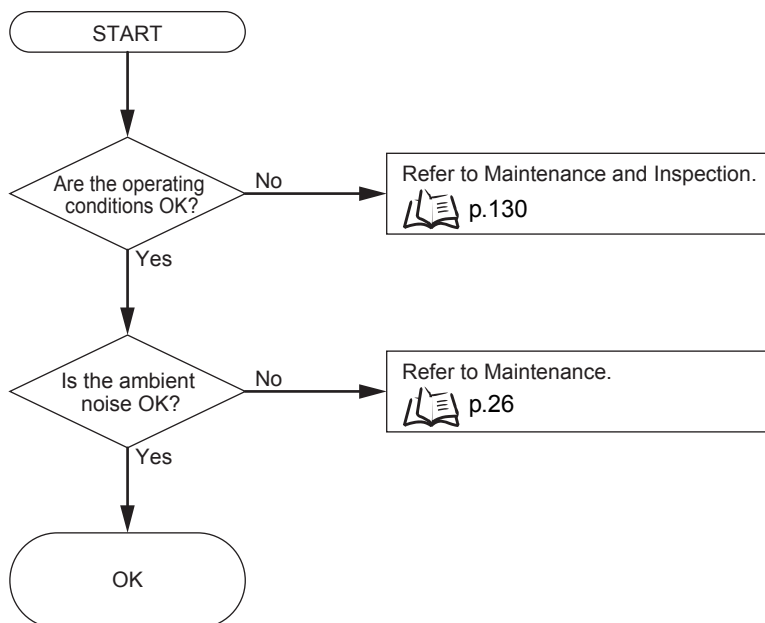

Host Device Communications Check Flowchart

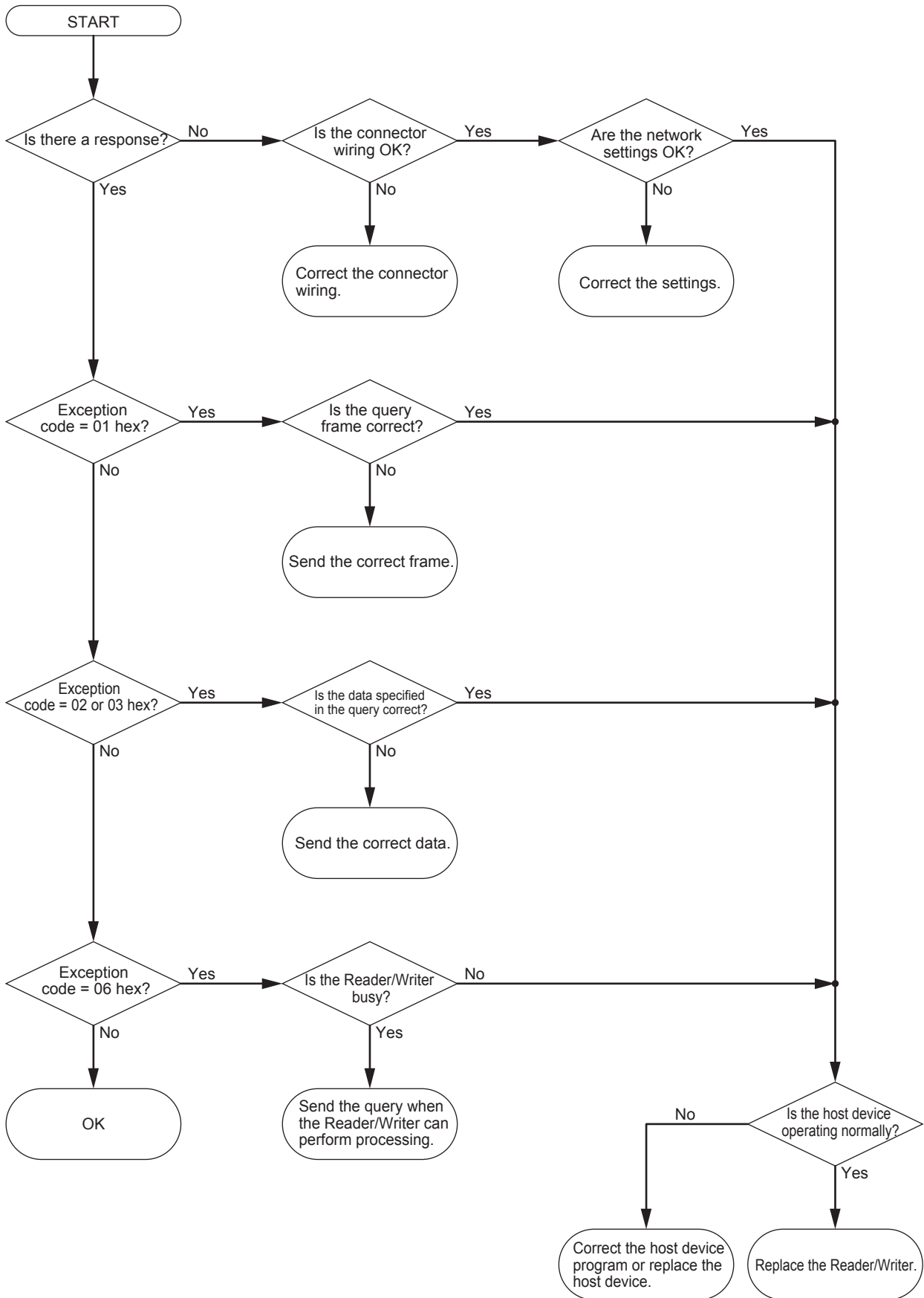

RF Tag Communications Check Flow

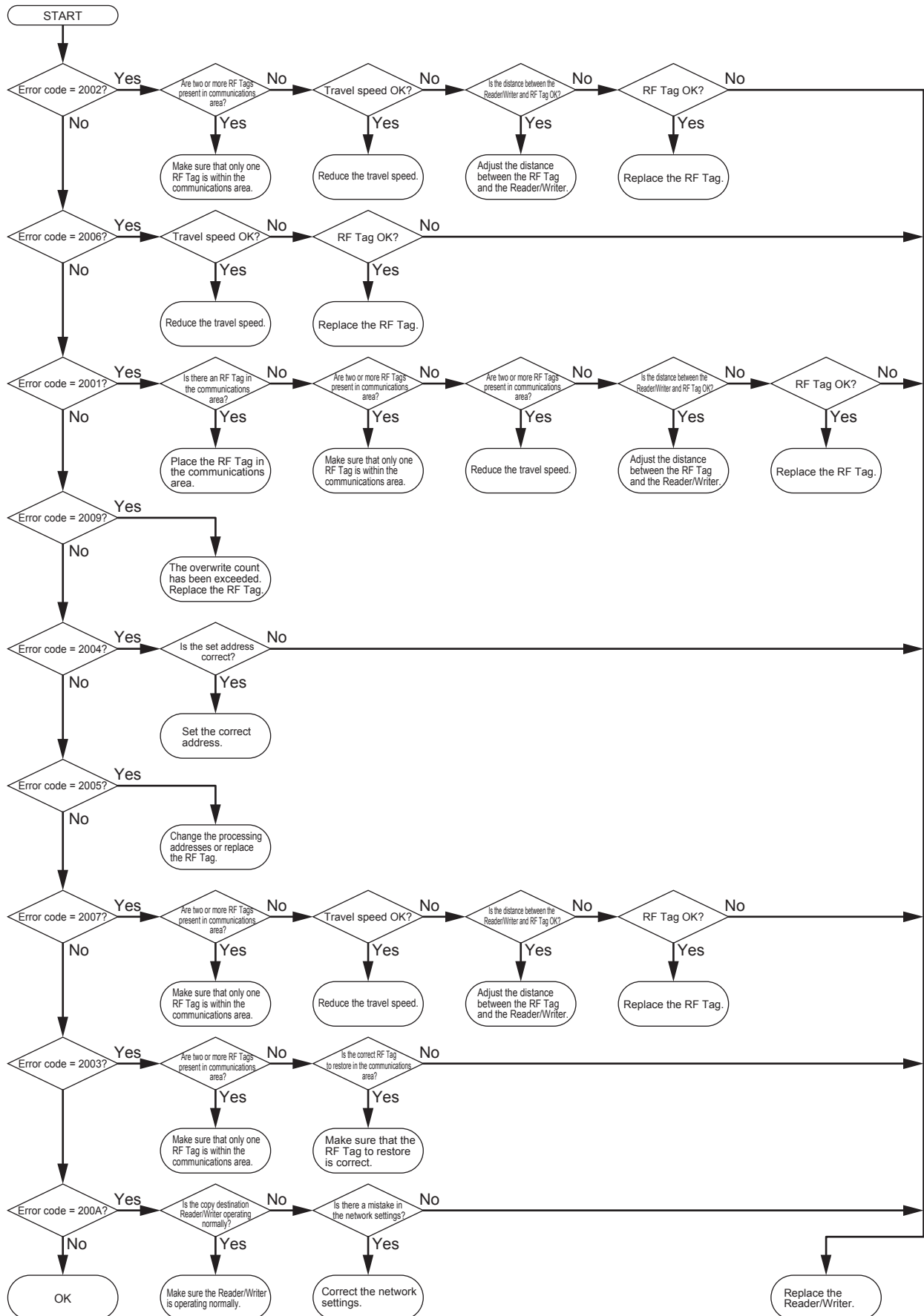

Safe Mode

In addition to the Run Mode that is used for normal operation, the Reader/Writer supports a Safe Mode operation mode. The Safe Mode is used when you do not remember the IP address that is set in the Reader/Writer.

If the Reader/Writer starts in Safe Mode, the following settings are always used. This allows you to access the Reader/Writer even if you forget the IP address so that you can set the IP address again.

IP address	192.168.1.200
Subnet mask	255.255.255.0
Port number	502



When the Reader/Writer is running in safe mode, some functions can not be used (Ex. RF tag communication and noise measurement function, etc). When you use the Reader/Writer normally, please start the Reader/Writer in RUN mode.

Starting in Safe Mode

- (1) Connect the control signal line (violet) from the Cable to the GND terminal on the DC power supply. Connect the other two lines (24P (brown) and 24N (blue)) to the DC power supply terminals.
- (2) Turn ON the power supply to the Reader/Writer.
- (3) The RUN indicator on the Reader/Writer will flash green

After the Reader/Writer starts in Safe Mode, use the Web browser or a Modbus query from the host device to reset or initialize the IP address.



If an error occurs in the Reader/Writer, the Reader/Writer may automatically start in Safe Mode. Refer to *Error Descriptions* in this Section for more information.



Section 8

Appendices

☒ Product Specifications	138
☒ Data Characteristics	154
☒ Reader/Writer Installation Precautions	164
☒ RF Tag Installation Precautions	166
☒ RF Tag Memory Map	186
☒ Chemical Resistance of the Reader/Writers and RF Tags	188
☒ Degree of Protection	191

Product Specifications

Reader/Writer

General Specifications

Item	Model	V680S-HMD64-ETN	V680S-HMD66-ETN
Dimensions		75 × 75 × 40 mm (W × H × D, excluding protruding parts)	120 × 120 × 40 mm (W × H × D, excluding protruding parts)
Power supply voltage		24 VDC (-15% to +10%)	
Consumption current		0.2A max.	
Ambient operating temperature		-10 to 55°C (with no icing)	
Ambient operating humidity		25% to 85% (with no condensation)	
Ambient storage temperature		-25 to 70°C (with no icing)	
Ambient storage humidity		25% to 85% (with no condensation)	
Insulation resistance		20 MΩ min. (at 500 VDC) between cable terminals and case	
Dielectric strength		1,000 VAC, 50/60 Hz for 1 min between cable terminals and case	
Vibration resistance		No abnormality after application of 10 to 500 Hz, 1.5-mm double amplitude, acceleration: 100 m/s ² , 10 sweeps in each of 3 axis directions (up/down, left/right, and forward/backward) for 11 minutes each	
Shock resistance		No abnormality after application of 500 m/s ² , 3 times each in 6 directions (Total: 18 times)	
Degree of protection		IP67 (IEC 60529:2001) Oil resistance equivalent to IP67F (JIS C 0920:2003, Appendix 1) <small>See Note 1</small>	
Materials		Case: PBT resin, Filled resin: Urethane resin	
Mass		Approx. 270 g	Approx. 640 g
Installation method		Four M4 screws Use a screw of 12mm or more in length.	
Host device communications interface		Ethernet 10BASE-T/100BASE-TX	
Host device communications protocol		MODBUS TCP	
Accessories		Instruction Seet Description of Regulations and Standard IP address label	Instruction Seet Description of Regulations and Standard IP address label Ferrite core

Note 1. Oil resistance has been tested using a specific oil as defined in the OMRON test method.

■ Dimensions

■ V680S-HMD64-ETN

(Unit: mm)

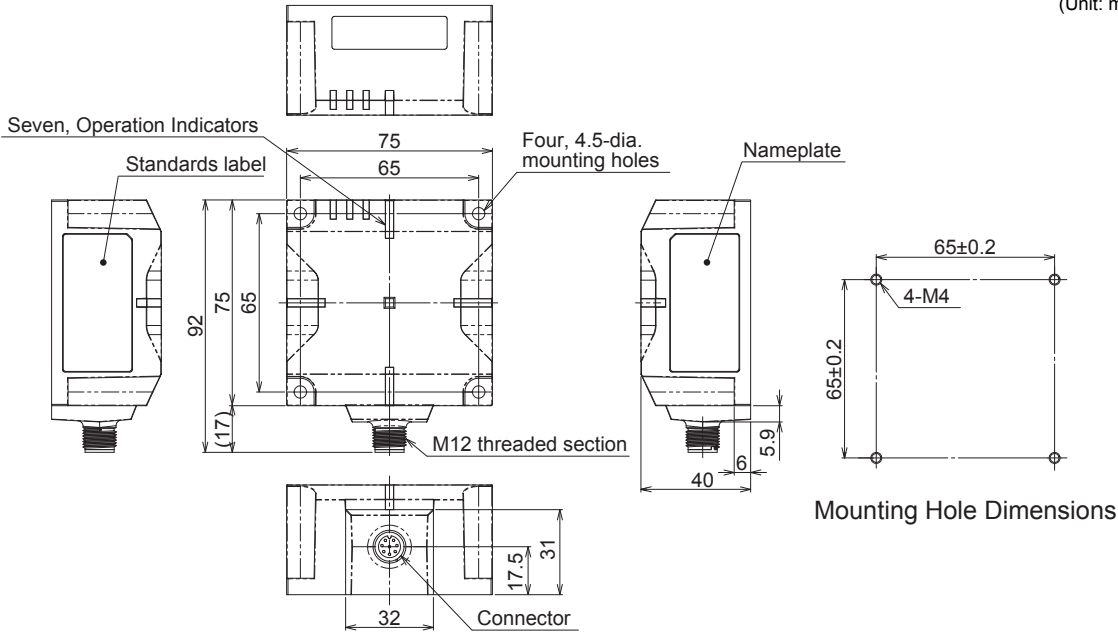

Mounting Hole Dimensions

■ V680S-HMD66-ETN

(Unit: mm)

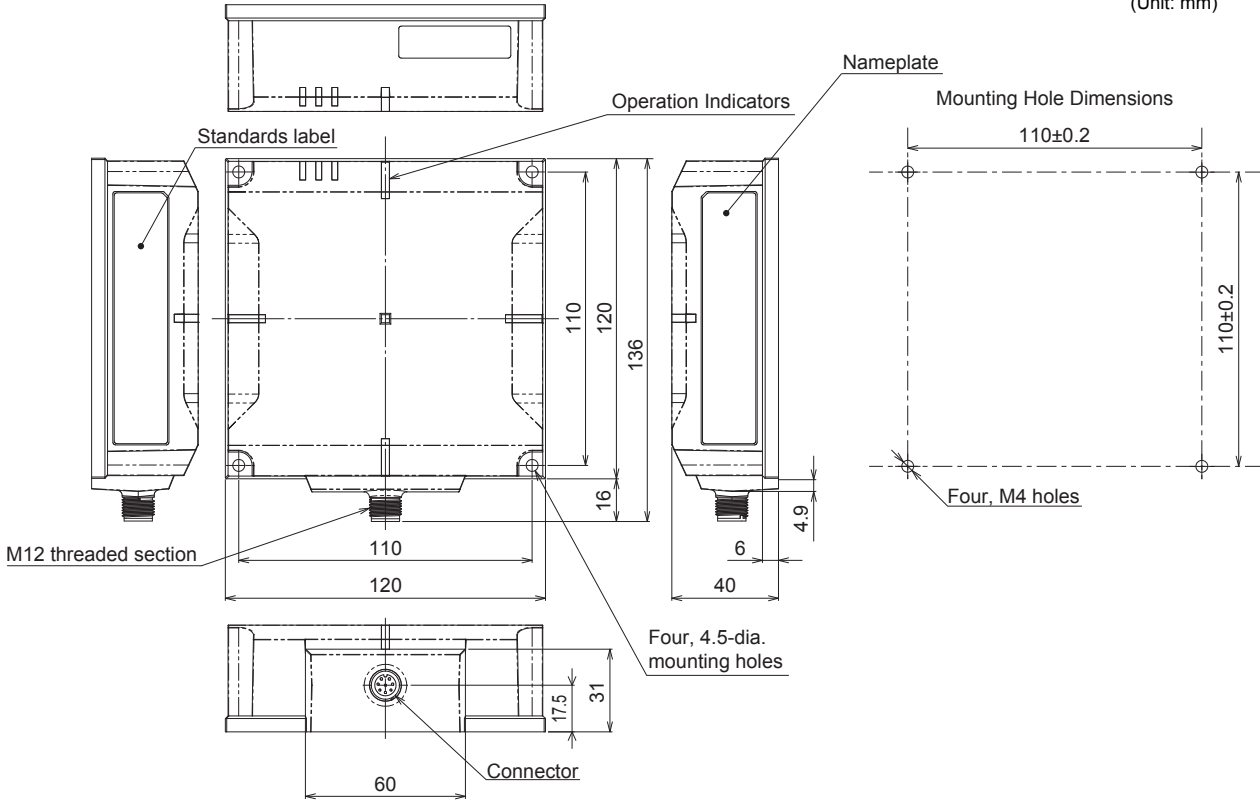

Extension cable

General Specifications

Item	Model	V680S-A40□M		
Type		Special connector--Special connector		
Length		10 m	20 m	50 m
Cable diameter		8 (number of conductors: 7)		
Insulation resistance		20 MΩ min. (at 500 VDC) between cable terminals and sheath		
Dielectric strength		1,000 VAC, 50/60 Hz for 1 min between cable terminals and sheath		
Standards		UL standards		
Degree of protection		IP67		
Maximum extension length		60 m		
Mass		Approx. 0.9 kg	Approx. 1.8 kg	Approx. 4.4 kg



The maximum extendable cable length using the cable and extension cable is 60 m.
Only one extension cable can be used.

CHECK!

Dimensions

V680S-A40□M

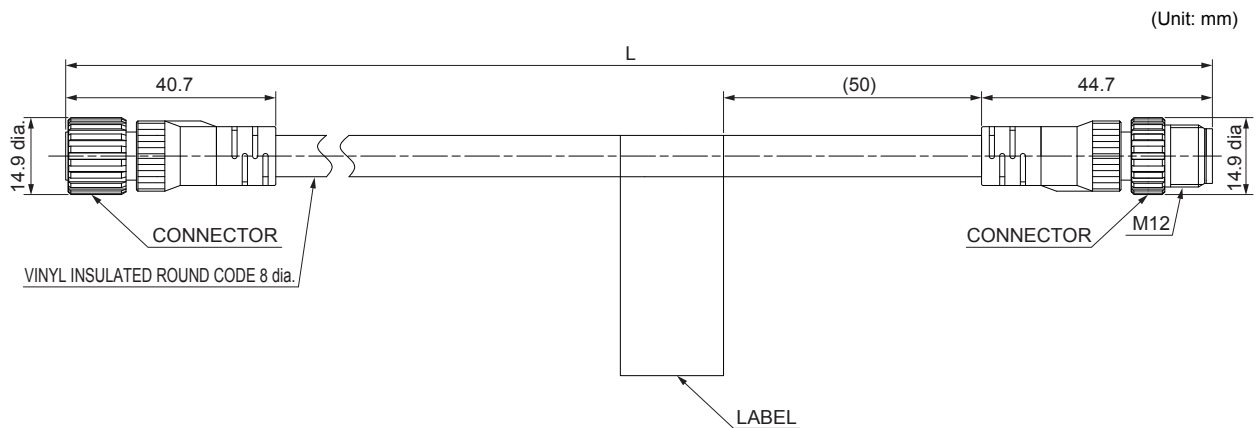

TYPE	L LENGTH
V680S-A40 10M	10000 ⁺¹⁰⁰⁰ ₀
V680S-A40 20M	20000 ⁺²⁰⁰⁰ ₀
V680S-A40 50M	50000 ⁺⁵⁰⁰⁰ ₀

Cables

General Specifications

Item	Model	V680S-A41□M			V680S-A42□M		
Type		Special connector--RJ45			Special connector--Loose wires		
Length		2 m	5 m	10 m	2 m	5 m	10 m
Cable diameter		8 (number of conductors: 7)					
Insulation resistance		20 MΩ min. (at 500 VDC) between cable terminals and sheath					
Dielectric strength		1,000 VAC, 50/60 Hz for 1 min between cable terminals and sheath					
Standards		UL standards					
Degree of protection		IP67					
Maximum extension length		60 m					
Mass		Approx. 0.2 kg	Approx. 0.5 kg	Approx. 0.9 kg	Approx. 0.2 kg	Approx. 0.5 kg	Approx. 0.9 kg

Dimensions

V680S-A41□M

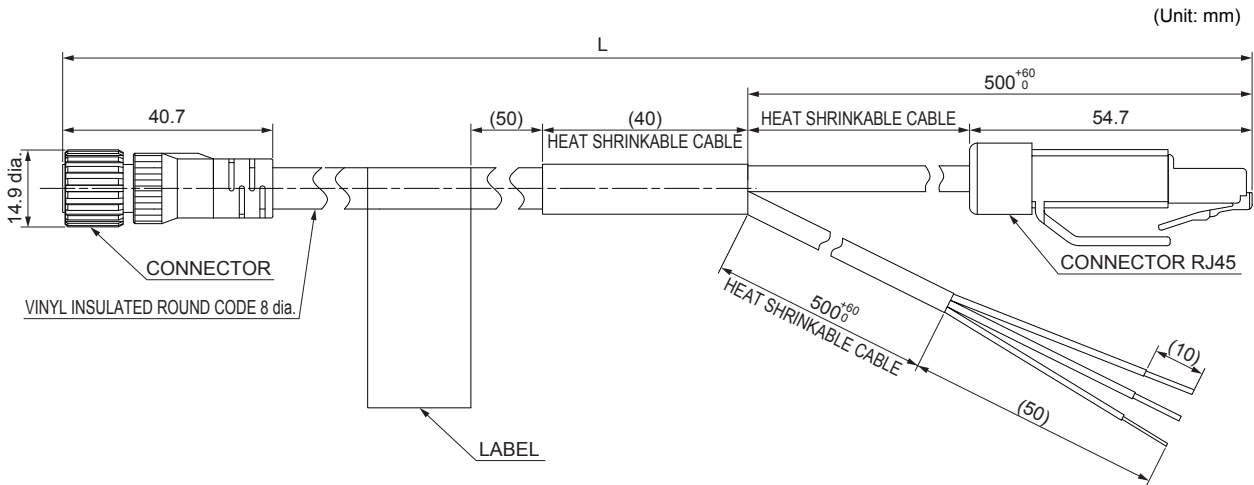

TYPE	L LENGTH
V680S-A41 2M	2000 ⁺¹⁵⁰ ₀
V680S-A41 5M	5000 ⁺³⁰⁰ ₀
V680S-A41 10M	10000 ⁺¹⁰⁰⁰ ₀

V680S-A42□M

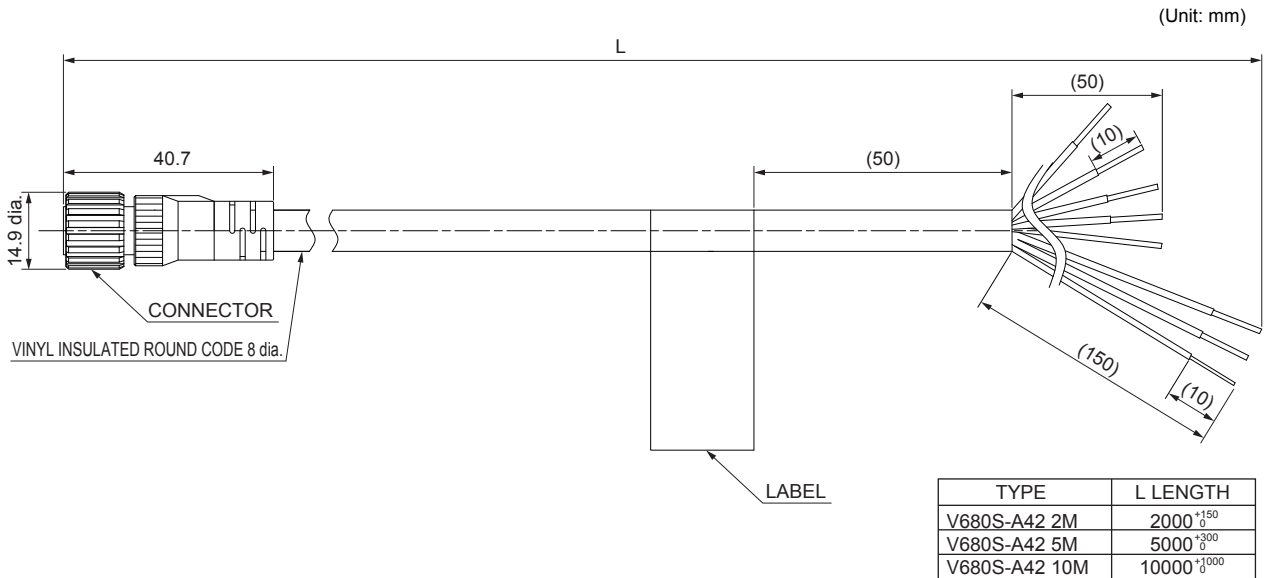

TYPE	L LENGTH
V680S-A42 2M	2000 ⁺¹⁵⁰ ₀
V680S-A42 5M	5000 ⁺³⁰⁰ ₀
V680S-A42 10M	10000 ⁺¹⁰⁰⁰ ₀

RF Tag

■ V680-D1KP54T

■ General Specifications

Item	Model	V680-D1KP54T
Memory capacity		1,000 bytes (user area)
Memory type		EEPROM
Data retention		10 years after writing at 85°C or less, 0.5 years after writing at 85°C to 125°C Total data retention at high temperatures exceeding 125°C is 10 hours <small>See Note 1.</small>
Write endurance		100,000 writes for each block (25°C)
Ambient operating temperature when communicating with RF Tags		-25 to 85°C (with no icing)
Ambient storage temperature with data retention		-40 to 125°C (with no icing)
Ambient operating humidity		35% to 95%
Degree of protection		IP67 (IEC 60529:2001) Oil resistance equivalent to IP67G (JIS C 0920:2003, Appendix 1) <small>See Note 2.</small>
Vibration resistance		No abnormality after application of 10 to 2,000 Hz, 1.5-mm double amplitude, acceleration: 150 m/s ² , 10 sweeps each in X, Y, and Z directions for 15 minutes each
Shock resistance		No abnormality after application of 500 m/s ² , 3 times each in X, Y, and Z directions (Total: 18 times)
Dimensions		20 dia. × 2.7 mm
Materials		PPS resin
Weight		Approx. 2 g
Metal countermeasures		None

Note 1. After storing RF Tags at high temperatures, rewrite the data even if changes are not required, high temperatures are those between 125 and 180°C.

2. Oil resistance has been tested using a specific oil as defined in the OMRON test method.

■ Dimensions

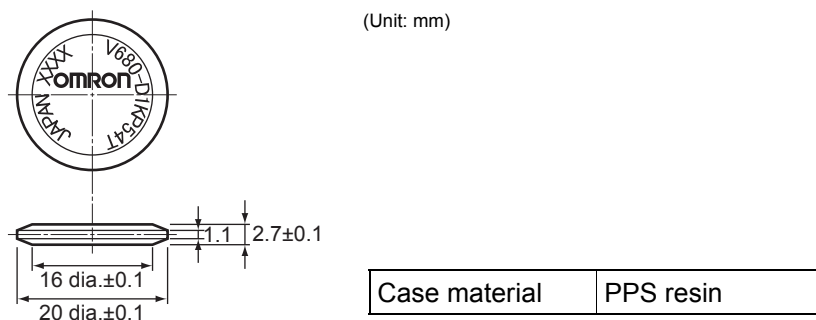

The RF Tag can be placed in the Attachment in either direction. The direction does not affect operation.



The ID code is written in the memory of the RF Tag and may be affected by data retention characteristics at high temperatures. Take suitable precautions when using the READ ID query for RF Tags operating at high temperatures.

V700-A80 Attachment

(Unit: mm)

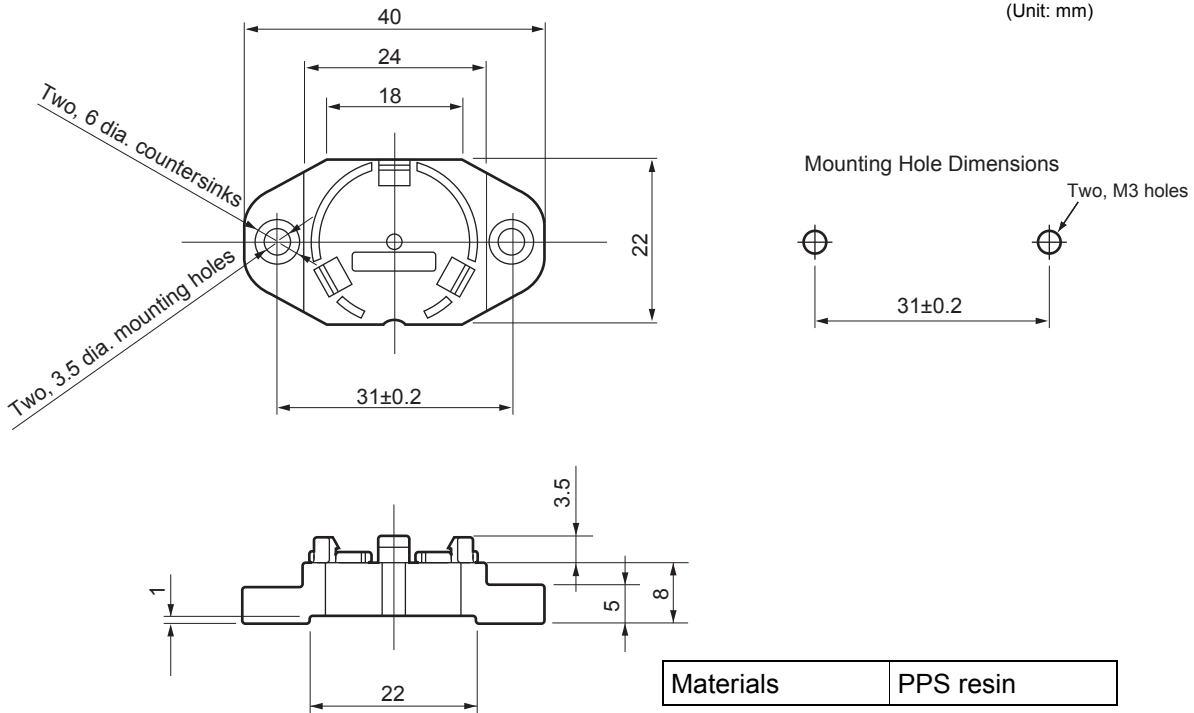

▪ **RF Tag Heat Resistance**

- Storing RF Tags under high temperatures or under heat cycles will adversely affect the performance of the internal parts and the service life of the RF Tags.

An LTPD of 10% was used for evaluation of RF Tags that reached the end of their service life after testing under the following test conditions.

- Heat cycle:
- 1,000 cycles of 30 minutes each between -10 and 150°C. No failures occurred in 22 samples.
 - 200 cycles of 30 minutes each between -10 and 180 °C. No failures occurred in 22 samples.
- High-temperature storage:
- 1,000 hours at 150°C. No failures occurred in 22 samples.
 - 200 hours at 180°C. No failures occurred in 22 samples.



LTPD: Lot Tolerance Percent Defective

The lower limit of the malfunction rate for lots to be considered unacceptable during reliability testing.

■ V680-D1KP66T/-D1KP66MT

▪ General Specifications

Item	Model	V680-D1KP66T	V680-D1KP66MT
Memory capacity		1,000 bytes (user area)	
Memory type		EEPROM	
Data retention		10 years after writing at 85°C or less, 0.5 years after writing at 85°C to 125°C Total data retention at high temperatures exceeding 125°C is 10 hours <small>See Note 1.</small>	
Write endurance		100,000 writes for each block (25°C)	
Ambient operating temperature when communicating with RF Tags		-25 to 85°C (with no icing)	
Ambient storage temperature with data retention		-40 to 125°C (with no icing)	
Ambient operating humidity		35% to 95%	
Degree of protection		IP68 (IEC 60529:2001) Oil resistance equivalent to IP67G (JIS C 0920:2003, Appendix 1) <small>See Note 2.</small>	
Vibration resistance		No abnormality after application of 10 to 2,000 Hz, 1.5-mm double amplitude, acceleration: 150 m/s ² , 10 sweeps each in X, Y, and Z directions for 15 minutes each	
Shock resistance		No abnormality after application of 500 m/s ² , 3 times each in X, Y, and Z directions (Total: 18 times)	
Dimensions		34 × 34 × 3.5 mm (W × H × D)	
Materials		Molded PPS resin	
Weight		Approx. 6 g	Approx. 7.5 g
Metal countermeasures		None	Provided

Note 1. After storing RF Tags at high temperatures, rewrite the data even if changes are not required, high temperatures are those between 125 and 180°C.

2. Oil resistance has been tested using a specific oil as defined in the OMRON test method.

The V680-D1KP66MT must be mounted on a metallic surface. The markings on the V680-D1KP66T and V680-D1KP66MT are shown below.

● V680-D1KP66MT



● V680-D1KP66T

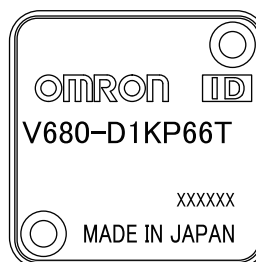

The marked surface is the communications surface. When mounting the RF Tag, face the marked surface toward the Reader/Writer.

CHECK!



The ID code is written in the memory of the RF Tag and may be affected by data retention characteristics at high temperatures. Take suitable precautions when using the READ ID query for RF Tags operating at high temperatures.

CHECK!

▪ **Dimensions**

V680-D1KP66T/-D1KP66MT

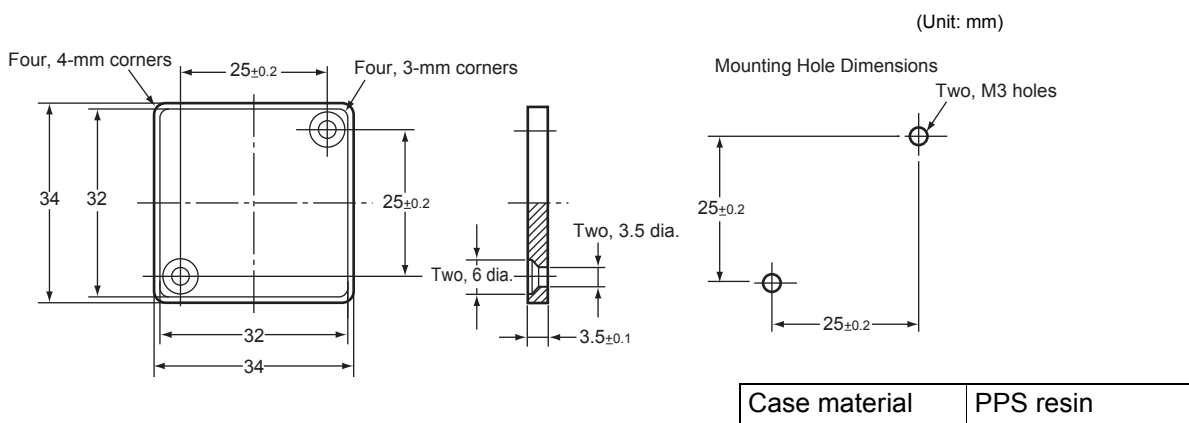

V600-A86 Attachment

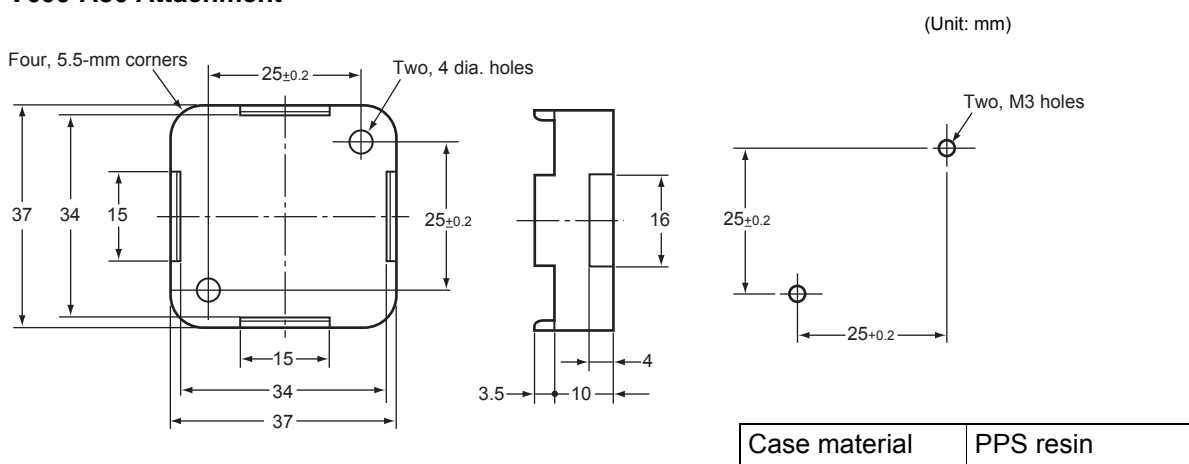

▪ **RF Tag Heat Resistance**

- Storing RF Tags under high temperatures or under heat cycles will adversely affect the performance of the internal parts and the service life of the RF Tags.

An LTPD of 10% was used for evaluation of RF Tags that reached the end of their service life after testing under the following test conditions.

Heat cycle: 1,000 cycles of 30 minutes each between -10 and 150°C. No failures occurred in 22 samples.

200 cycles of 30 minutes each between -10 and 180 °C. No failures occurred in 22 samples.

High-temperature storage: 1,000 hours at 150°C. No failures occurred in 22 samples.

200 hours at 180°C. No failures occurred in 22 samples.



LTPD: Lot Tolerance Percent Defective

The lower limit of the malfunction rate for lots to be considered unacceptable during reliability testing.

■ V680-D1KP66T-SP

■ General Specifications

Item	Specification
Memory capacity	1,000 bytes
Memory type	EEPROM
Data retention	10 years (85°C or less)
Write endurance	100,000 writes for each block (25°C)
Ambient operating temperature	During RF Tag communications: -25 to 70°C (with no icing) Not during RF Tag communications: -40 to 110°C (with no icing)
Ambient operating humidity	35% to 95% (with no condensation)
Ambient storage temperature	-40 to 110°C (with no icing)
Ambient storage humidity	35% to 95% (with no condensation)
Vibration resistance	10 to 2,000 Hz, 1.5-mm double amplitude, acceleration: 150 m/s ² , 10 sweeps each in 3 directions for 15 minutes each
Shock resistance	500 m/s ² , 3 times each in 3 directions (Total: 18 times)
Dimensions	95 × 36.5 × 6.5 mm (W × H × D, excluding protruding parts)
Degree of protection	IP67
Materials	Exterior: PFA fluoro-resin RF Tag filling: PPS resin
Weight	Approx. 20 g
Installation method	Two M5 screws
Metal countermeasures	None

■ Dimensions

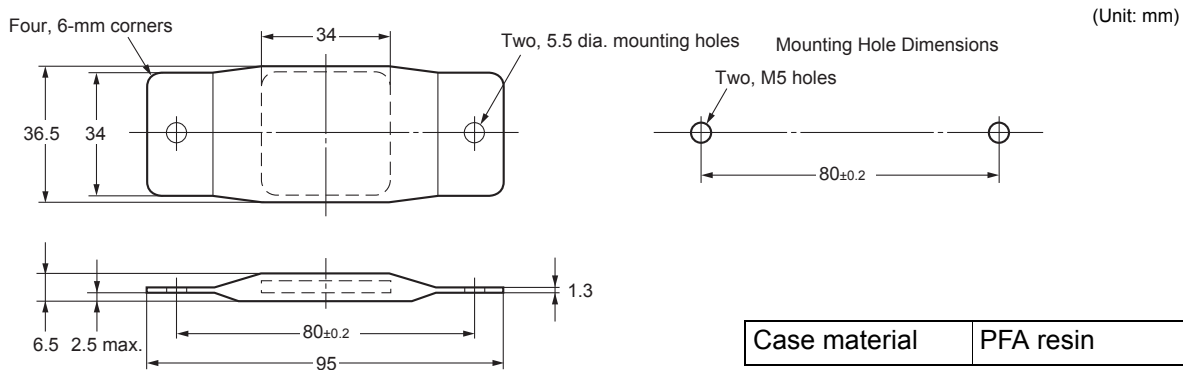

The marked surface is the communications surface. When mounting the RF Tag, face the marked surface toward the Reader/Writer.

■ V680-D1KP58HTN

■ General Specifications

Item	Model	V680-D1KP58HTN
Memory capacity		1,000 bytes (user area)
Memory type		EEPROM
Data retention		10 years after writing at 85°C or less, 0.5 years after writing at 85°C to 125°C Total data retention at high temperatures exceeding 125°C is 10 hours
Write endurance		100,000 writes for each block (25°C)
Ambient operating temperature when communicating with RF Tags		-25 to 85°C (with no icing)
Ambient storage temperature		-40 to 250°C (with no icing) (Data retention: -40 to 125°C)
Ambient storage humidity		No restrictions.
Degree of protection		IP67 (IEC 60529:2001) Oil resistance equivalent to IP67G (JIS C 0920:2003, Appendix 1) <small>See Note</small>
Vibration resistance		No abnormality after application of 10 to 2,000 Hz, 1.5-mm double amplitude, acceleration: 150 m/s ² , 10 sweeps each in X, Y, and Z directions for 15 minutes each
Shock resistance		No abnormality after application of 500 m/s ² , 3 times each in X, Y, and Z directions (Total: 18 times)
Materials		Exterior: PPS resin
Weight		Approx. 70 g

Note: Oil resistance has been tested using a specific oil as defined in the OMRON test method.

▪ Dimensions
V680-D1KP58HTN

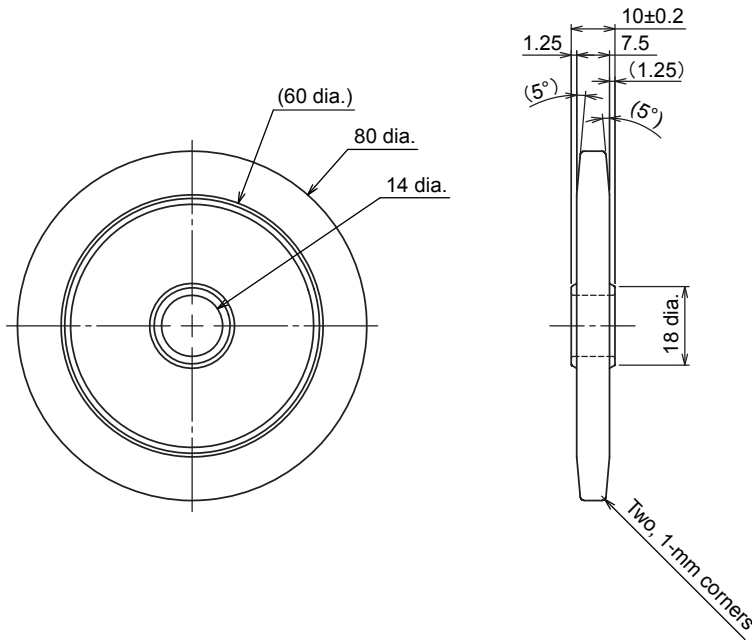

(Unit: mm)

V680-A80 Attachment

This Attachment is used to hold V680-D1KP58HTN ID Tags.

Applicable model: V680-D1KP58HTN

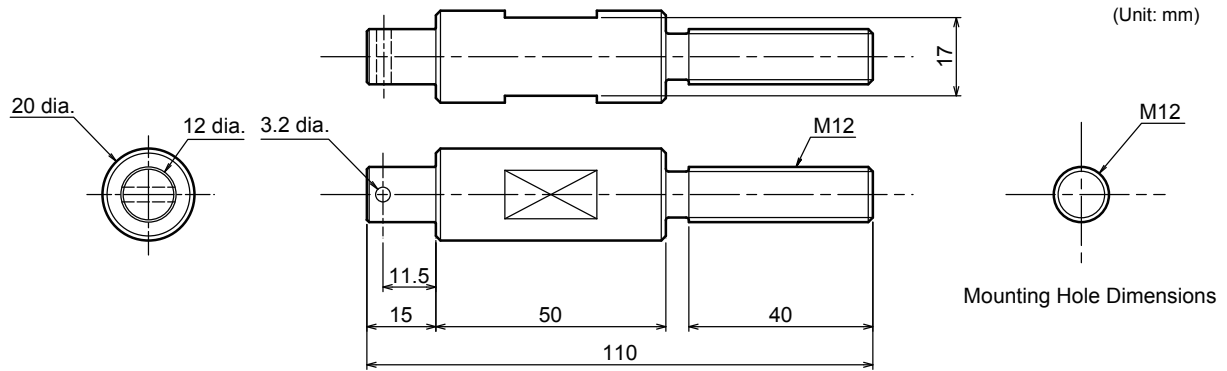

(Unit: mm)

Accessories: 2 nuts (M12)

1 split pin (nominal dimensions: 3.2-mm dia. x 20-mm length)

High-temperature Applications (V680-D1KP58HTN)

Data Retention

- Due to the characteristics of EEPROM, any data that is written to an RF Tag may be lost if it is used in a high-temperature environment that exceeds 125°C for a total of more than 10 hours. Always reset the data holding time before a total of 10 hours is reached.
- Communications between the Reader/Writer and RF Tags may fail in high-temperature environments of 85°C or higher. Do not perform communications between the Reader/Writer and RF Tag in a high-temperature environment of 85°C or higher.
- Due to the characteristics of EEPROM, the UID (RF Tag ID code) may be lost if an RF Tag is used in a high-temperature environment that exceeds 125°C. Do not use commands that use the UID in high-temperature environments that exceed 125°C.
 - Do not use the ID READ command.
 - You cannot use FIFO trigger communications.

Total Usage Time

This section gives the total time that an RF Tag can be placed at high temperatures.

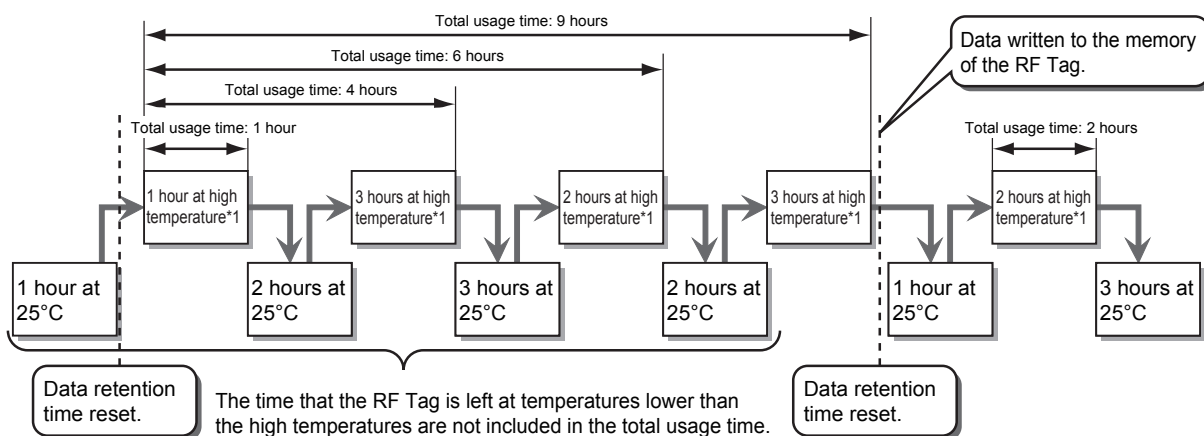

Fig. Conceptual Diagram of Resetting the Data Retention Time

*1 High temperatures are those between 125 and 250°C.

Data Retention Time Reset Procedure

Always use the following procedure to reset the data holding time before a total of 10 hours is reached.

When Using RF Tag Memory Addresses 0010 to 0015 hex

1. Read the data from RF Tag addresses 0010 to 0015 hex.

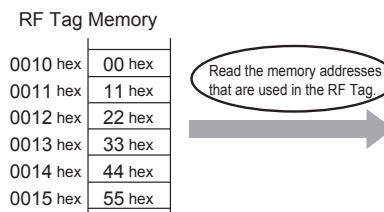

2. Write the read data to RF Tag memory addresses 0010 to 0015 hex.

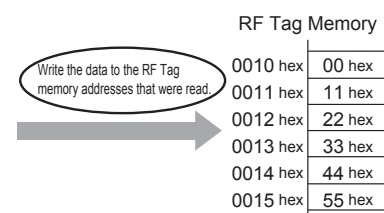

The data retention time is reset only for the RF Tag memory addresses that are written. To reset the data retention time, write the same data to all of the memory addresses that are used in the RF Tag.

▪ **Heat Resistance**

Storing RF Tags under high temperatures or under heat cycles will adversely affect the performance of the internal parts and the service life of the RF Tags.

The RF Tag were placed in the following high temperatures and then evaluated in-house. It was confirmed that no problems occurred.

- 1) 2,000 cycles of 30 minutes each between room temperature and 200°C
- 2) 500 hours at 250°C

■ V680-D8KF67/-D8KF67M

■ General Specifications

Item	Model	V680-D8KF67	V680-D8KF67M
Memory capacity		8,192 bytes (user area)	
Memory type		FRAM	
Data retention		10 years after writing at 55°C or less, 2.9 years after writing at 55°C to 85°C	
Memory life		10 billion writes for each block, Number of accesses: <i>See Note 2</i> 10 billion writes	
Ambient operating temperature		-25 to 85°C (with no icing)	
Ambient storage temperature		-40 to 85°C (with no icing)	
Ambient operating humidity		35% to 85%	
Degree of protection		IP67 (IEC 60529) Oil resistance equivalent to IP67G (JIS C 0920:2003, Appendix 1) <i>See Note 2.</i>	
Vibration resistance		No abnormality after application of 10 to 2,000 Hz, 1.5-mm double amplitude, acceleration: 150 m/s ² , 10 sweeps each in X, Y, and Z directions for 15 minutes each	
Shock resistance		No abnormality after application of 500 m/s ² , 3 times each in X, Y, and Z directions (Total: 18 times)	
Dimensions		40 × 40 × 4.5 mm (W × H × D)	
Materials		Case: PBT resin, Filling: Epoxy resin	
Weight		Approx. 8 g	Approx. 8.5 g
Metal countermeasures		None	Provided

Note 1. The number of accesses is the total number of reads and writes.

Note 2. Oil resistance has been tested using a specific oil as defined in the OMRON test method.

The V680-D8KF67M must be mounted on a metallic surface. The markings on the V680-D8KF67 and V680-D8KF67M are shown below.

● V680-D8KF67M

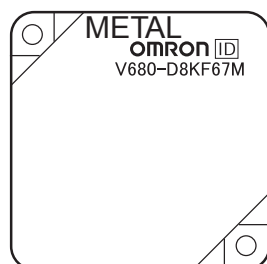

● V680-D8KF67



The marked surface is the communications surface. When mounting the RF Tag, face the marked surface toward the Reader/Writer.

▪ Dimensions

V680-D8KF67/-D8KF67M

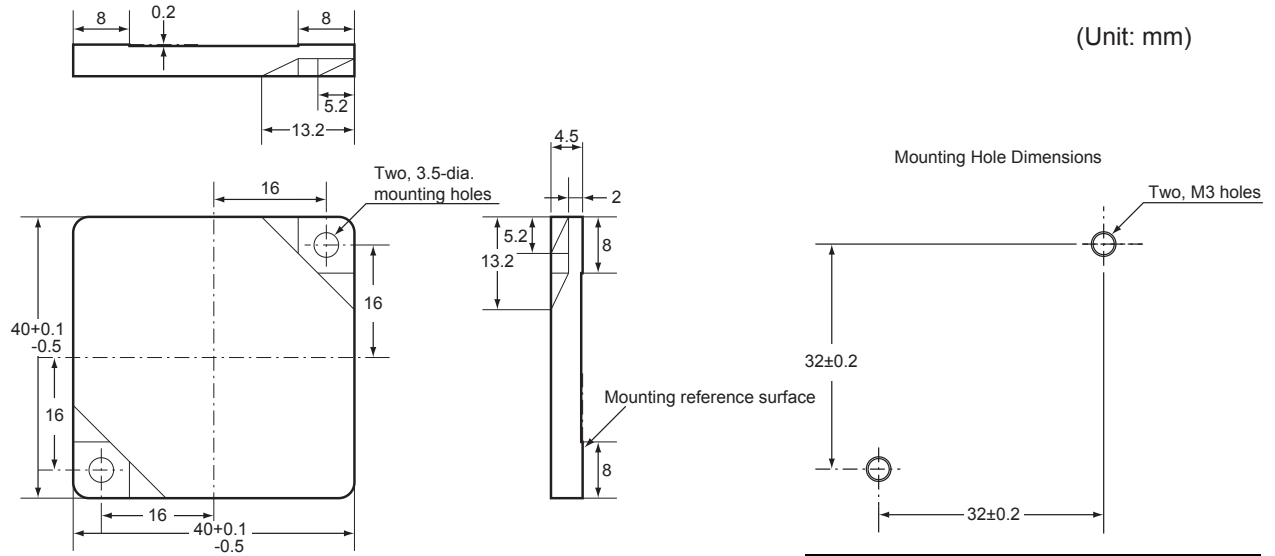

Case material	PBT resin
Filling	Epoxy resin

■ V680-D8KF68A

■ General Specifications

Item	Model	V680-D8KF68A
Memory capacity		8,192 bytes (user area)
Memory type		FRAM
Data retention		10 years after writing (70°C max.), 6 years after writing (85°C max.)
Write Endurance		10 billion times per block (85°C or less) Access frequency <i>See Note 1.</i> : 10 billion times
Ambient operating temperature		-20 to 85°C (with no icing)
Ambient storage temperature		-40 to 85°C (with no icing)
Ambient operating humidity		35% to 85%
Degree of protection		IP67 (IEC 60529) Oil resistance equivalent to IP67G (JIS C 0920:2003, Appendix 1) <i>See Note 2.</i>
Vibration resistance		No abnormality after application of 10 to 500 Hz, 1.5-mm double amplitude, acceleration: 100 m/s ² , 10 sweeps each in X, Y, and Z directions for 11 minutes each
Shock resistance		No abnormality after application of 500 m/s ² , 3 times each in X, Y, and Z directions (Total: 18 times)
Dimensions		86 × 54 × 10 mm (W × H × D)
Materials		Case: PBT resin, Filling: Epoxy resin
Weight		Approx. 50 g
Metal countermeasures		None

Note 1. The total communications frequency of the Read or Write is called an access frequency.

2. Oil resistance has been tested using a specific oil as defined in the OMRON test method.

■ Dimensions

V680-D8KF68A

(Unit: mm)

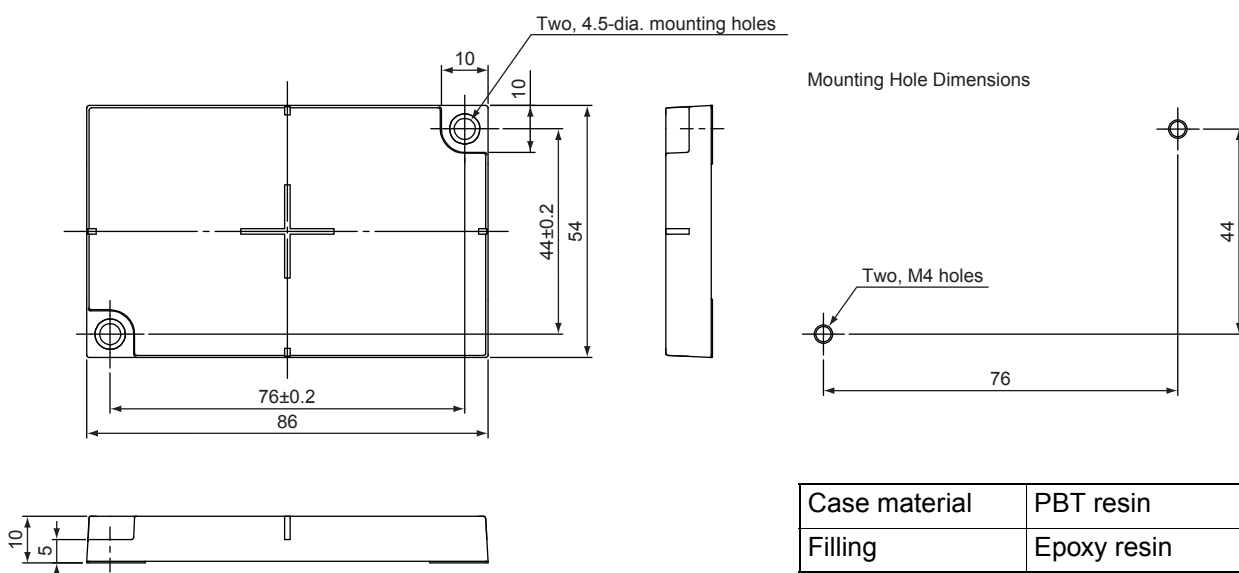

The marked surface is the communications surface. When mounting the RF Tag, face the marked surface toward the Reader/Writer.

Data Characteristics

Communications Distance Specifications

■ V680S-HMD64-ETN

Reader/Writer	RF Tag	Communications distance specification	
V680S-HMD64-ETN (mounted to metallic material)	V680-D8KF67 (mounted to non-metallic material)	Read	5.0 to 50.0 mm (axis offset: ± 10 mm)
		Write	5.0 to 50.0 mm (axis offset: ± 10 mm)
	V680-D8KF67M (mounted to metallic material)	Read	3.0 to 40.0 mm (axis offset: ± 10 mm)
		Write	3.0 to 40.0 mm (axis offset: ± 10 mm)
	V680-D8KF68A (mounted to non-metallic material)	Read	7.5 to 75.0 mm (axis offset: ± 10 mm)
		Write	7.5 to 75.0 mm (axis offset: ± 10 mm)
	V680-D1KP54T (mounted to non-metallic material)	Read	0.0 to 33.0 mm (axis offset: ± 10 mm)
		Write	0.0 to 28.0 mm (axis offset: ± 10 mm)
	V680-D1KP66T (mounted to non-metallic material)	Read	0.0 to 47.0 mm (axis offset: ± 10 mm)
		Write	0.0 to 42.0 mm (axis offset: ± 10 mm)
	V680-D1KP66MT (mounted to metallic material)	Read	0.0 to 35.0 mm (axis offset: ± 10 mm)
		Write	0.0 to 30.0 mm (axis offset: ± 10 mm)
	V680-D1KP66T-SP (mounted to non-metallic material)	Read	0.0 to 42.0 mm (axis offset: ± 10 mm)
		Write	0.0 to 37.0 mm (axis offset: ± 10 mm)
V680-D1KP58HTN	Read	7.5 to 75.0 mm (axis offset: ± 10 mm)	
	Write	7.5 to 75.0 mm (axis offset: ± 10 mm)	

■ Installation Conditions

● V680-D8KF67

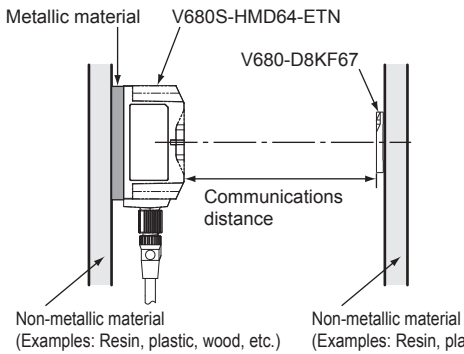

● V680-D8KF67M

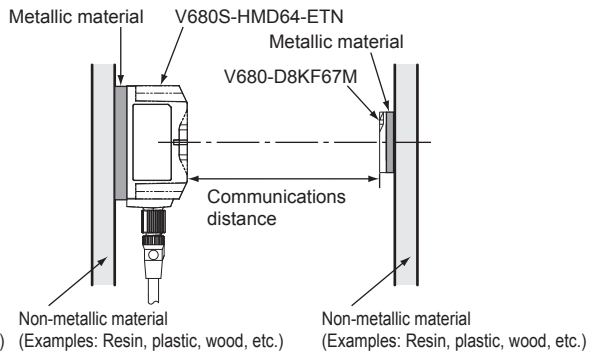

● V680-D8KF68/-D8KF68A

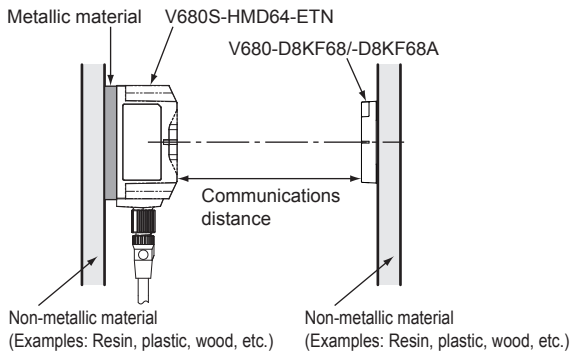

● V680-D1KP54T

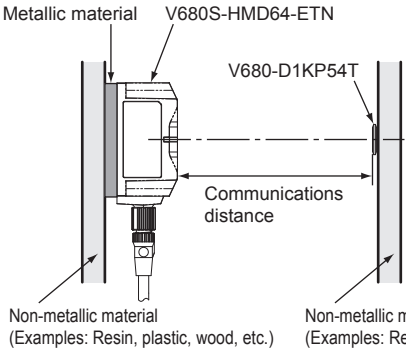

● V680-D1KP66T

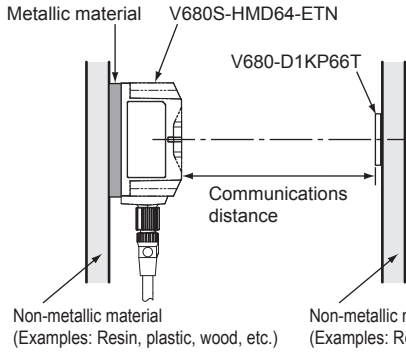

● V680-D1KP66M

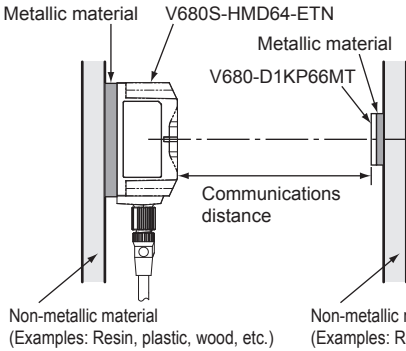

● V680-D1KP66T-SP

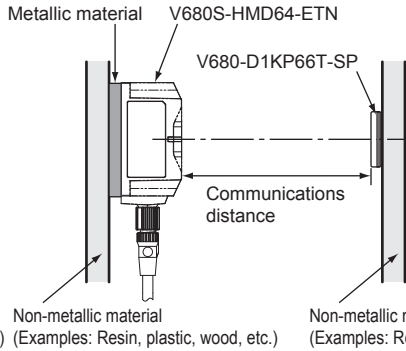

● V680-D1KP58HTN

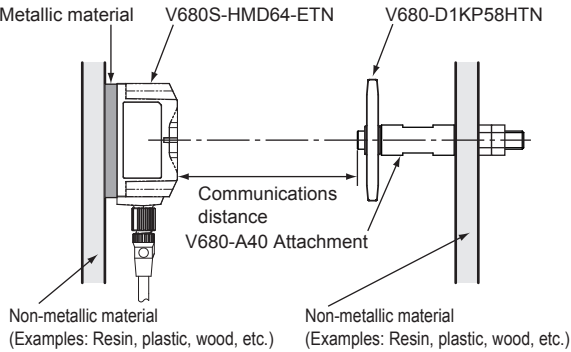

■ V680S-HMD66-ETN

Reader/Writer	RF Tag	Communications distance specification	
		Read	Write
V680S-HMD66-ETN (mounted to metallic material)	V680-D8KF67 (mounted to non-metallic material)	Read	7.0 to 70.0 mm (axis offset: ±10 mm)
		Write	7.0 to 70.0 mm (axis offset: ±10 mm)
	V680-D8KF67M (mounted to metallic material)	Read	4.0 to 45.0 mm (axis offset: ±10 mm)
		Write	4.0 to 45.0 mm (axis offset: ±10 mm)
	V680-D8KF68A (mounted to non-metallic material)	Read	10.0 to 100.0 mm (axis offset: ±10 mm)
		Write	10.0 to 100.0 mm (axis offset: ±10 mm)
	V680-D1KP54T (mounted to non-metallic material)	Read	7.5 to 75.0 mm (axis offset: ±10 mm)
		Write	7.5 to 75.0 mm (axis offset: ±10 mm)
	V680-D1KP66T (mounted to non-metallic material)	Read	0.0 to 45.0 mm (axis offset: ±10 mm)
		Write	0.0 to 38.0 mm (axis offset: ±10 mm)
V680-D1KP66MT (mounted to metallic material)	Read	0.0 to 37.0 mm (axis offset: ±10 mm)	
	Write	0.0 to 30.0 mm (axis offset: ±10 mm)	
V680-D1KP66T-SP (mounted to non-metallic material)	Read	0.0 to 59.0 mm (axis offset: ±10 mm)	
	Write	0.0 to 52.0 mm (axis offset: ±10 mm)	
V680-D1KP58HTN	Read	10.0 to 90.0 mm (axis offset: ±10 mm)	
	Write	10.0 to 800.0 mm (axis offset: ±10 mm)	

■ Installation Conditions

● V680-D8KF67

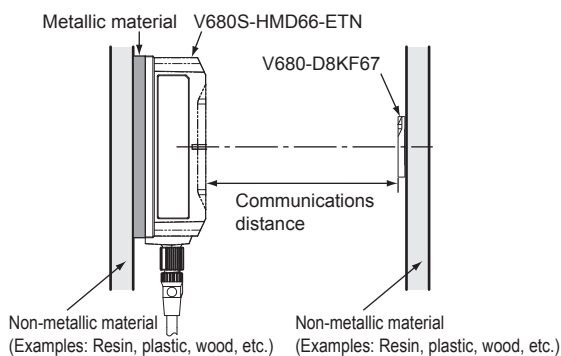

● V680-D8KF67M

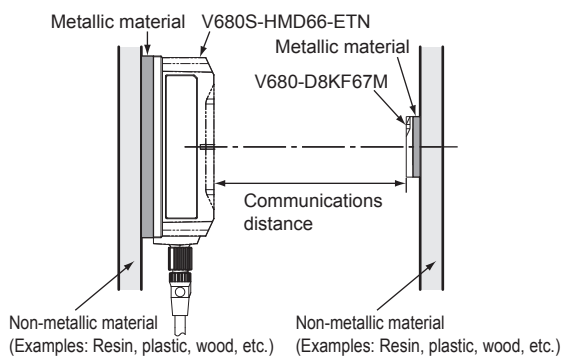

● V680-D8KF68/-D8KF68A

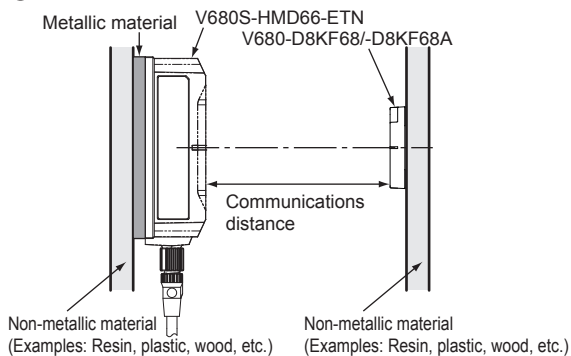

● V680-D1KP54T

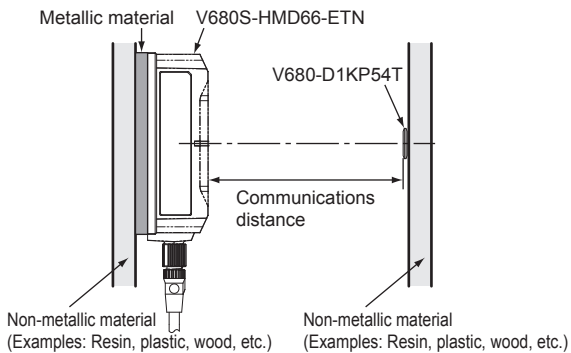

● V680-D1KP66T

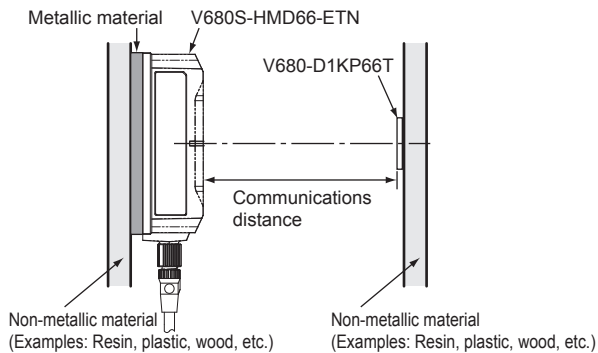

● V680-D1KP66MT

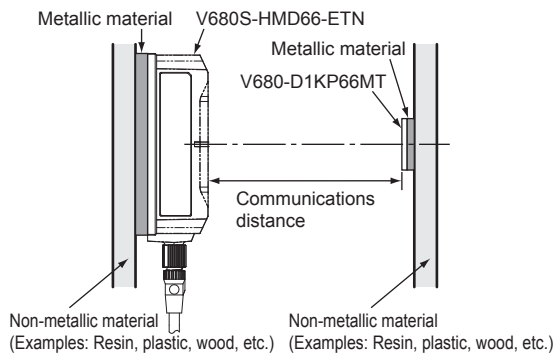

● V680-D1KP66T-SP

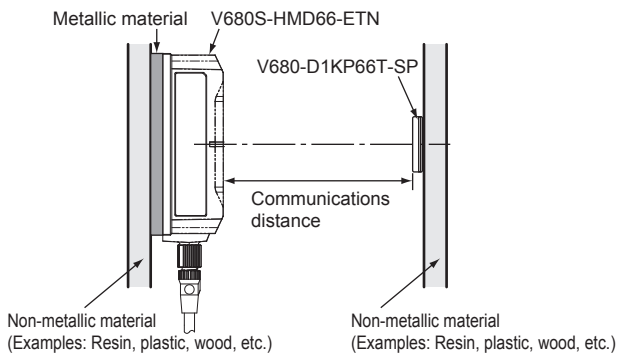

● V680-D1KP58HTN

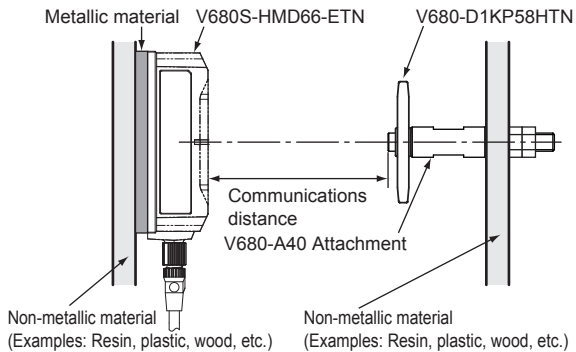

RF Tag Communications Range (for Reference Only)

■ V680S-HMD64-ETN

(Unit: mm)

● V680S-HMD64-ETN & V680-D1KP54T
(Back Surface: Metal)

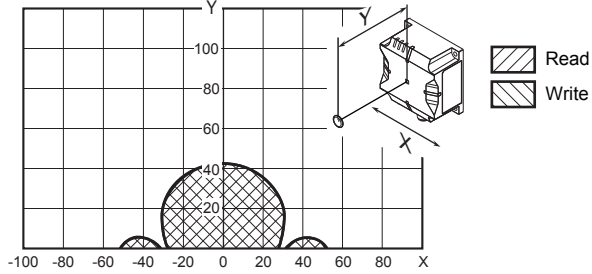

● V680S-HMD64-ETN & V680-D1KP66T
(Back Surface: Metal)

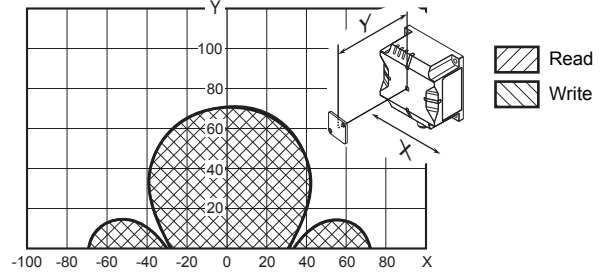

● V680S-HMD64-ETN & V680-D1KP66MT
(Back Surface: Metal) (Back Surface: Metal)

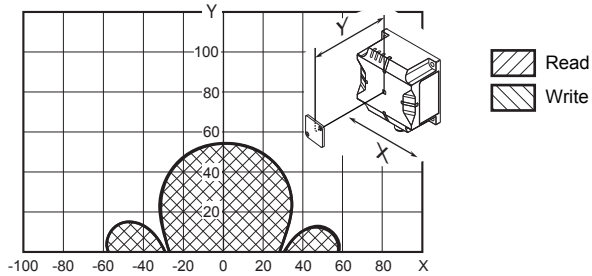

● V680S-HMD64-ETN & V680-D1KP66T-SP
(Back Surface: Metal)

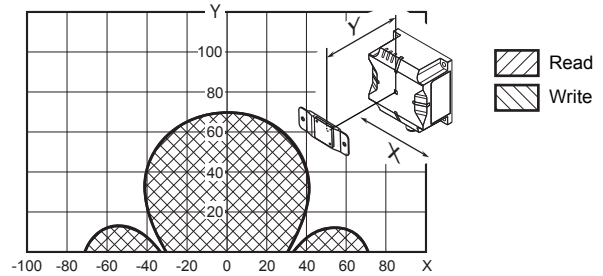

● V680S-HMD64-ETN & V680-D1KP58HTN
(Back Surface: Metal) (with Attachment, V680-A80)

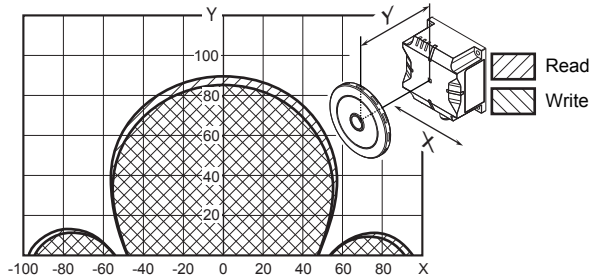

(Unit: mm)

● V680S-HMD64-ETN & V680-D8KF67
(Back Surface: Metal)

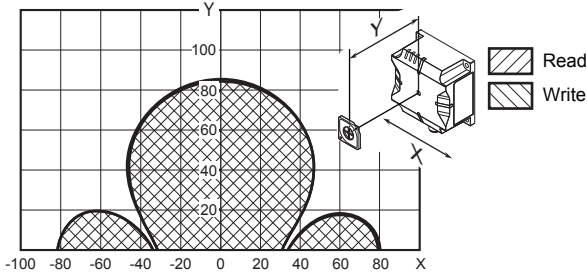

● V680S-HMD64-ETN & V680-D8KF67M
(Back Surface: Metal) (Back Surface: Metal)

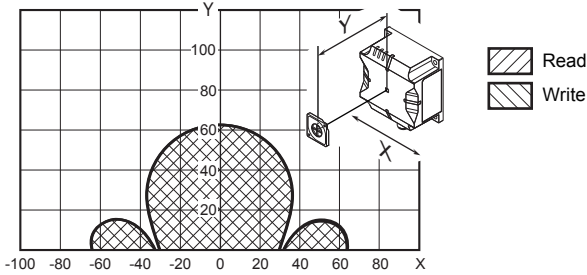

● V680S-HMD64-ETN & V680-D8KF68A
(Back Surface: Metal) (Horizontal-facing RF Tag)

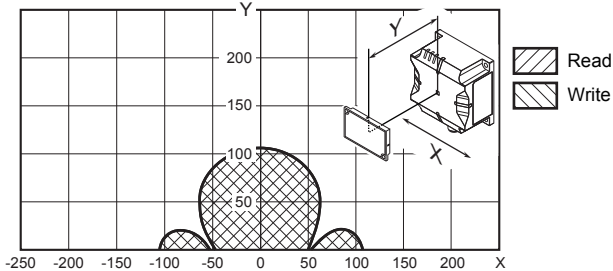

● V680S-HMD64-ETN & V680-D8KF68A
(Back Surface: Metal) (Vertical-facing RF Tag)

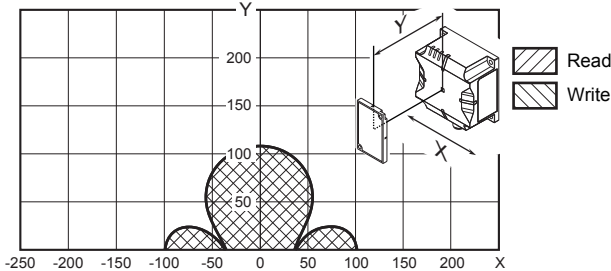

■ V680S-HMD66-ETN

(Unit: mm)

- V680S-HMD66-ETN & V680-D1KP54T
(Back Surface: Metal)

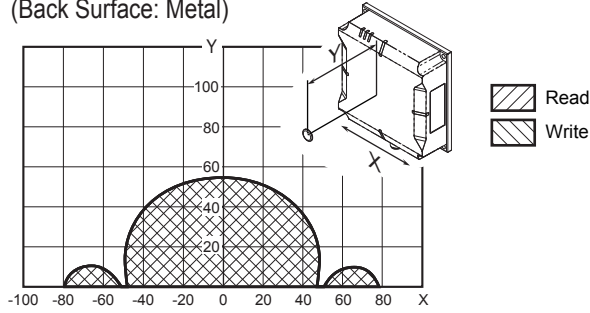

- V680S-HMD66-ETN & V680-D1KP66T
(Back Surface: Metal)

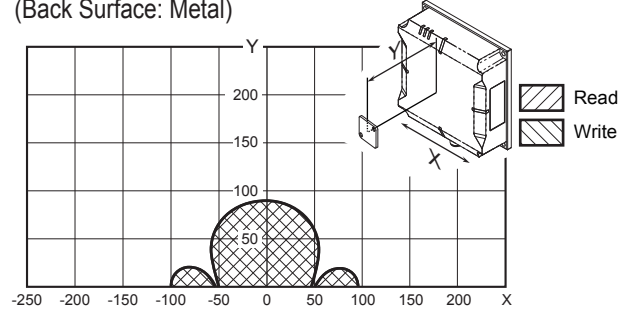

- V680S-HMD66-ETN & V680-D1KP66MT
(Back Surface: Metal) (Back Surface: Metal)

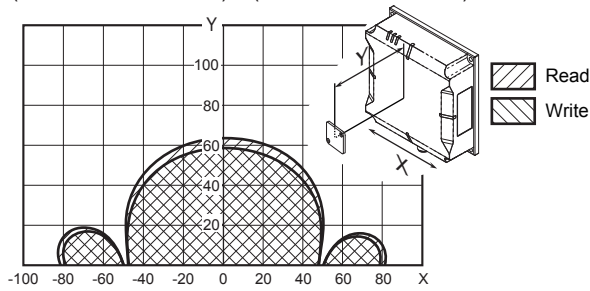

- V680S-HMD66-ETN & V680-D1KP66T-SP
(Back Surface: Metal)

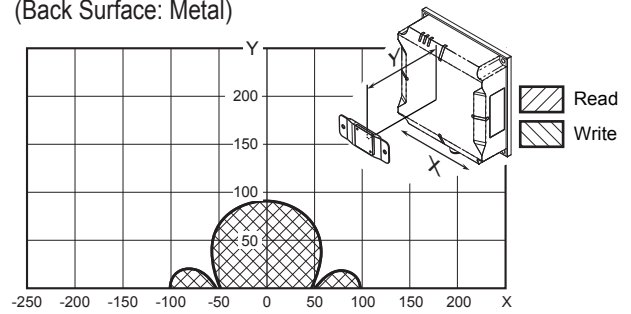

- V680S-HMD66-ETN & V680-D1KP58HTN
(Back Surface: Metal) (with Attachment, V680-A80)

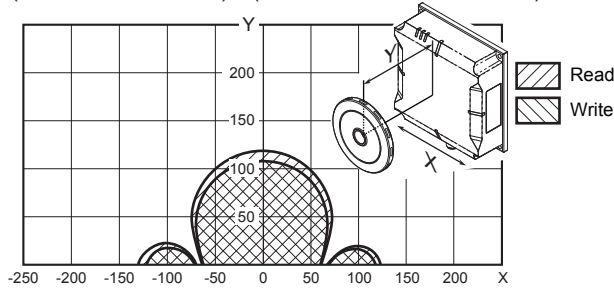

(Unit: mm)

● V680S-HMD66-ETN & V680-D8KF67
(Back Surface: Metal)

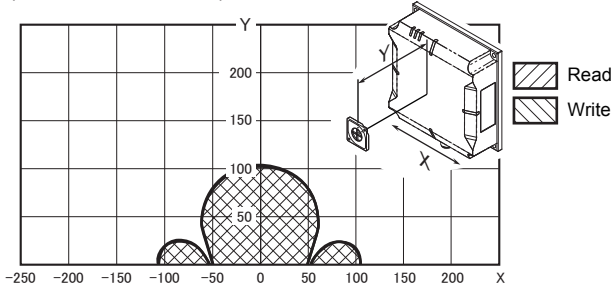

● V680S-HMD66-ETN & V680-D8KF67M
(Back Surface: Metal) (Back Surface: Metal)

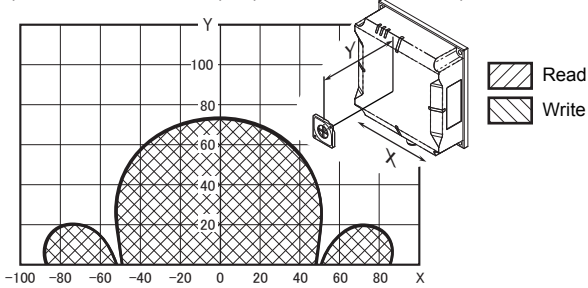

● V680S-HMD66-ETN & V680-D8KF68A
(Back Surface: Metal) (Horizontal-facing RF Tag)

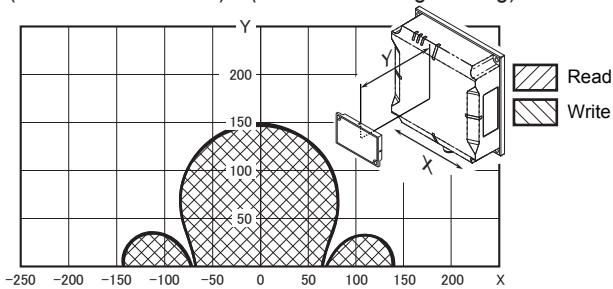

● V680S-HMD66-ETN & V680-D8KF68A
(Back Surface: Metal) (Vertical-facing RF Tag)

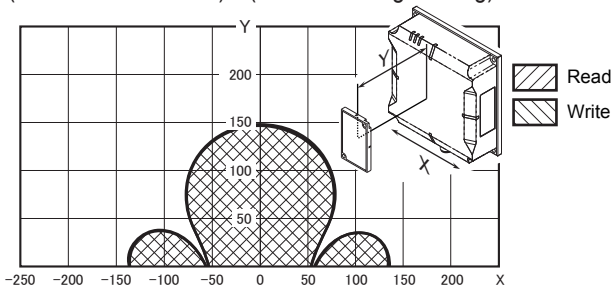

RF Tag Communications Time (for Reference Only)

Communications Time

V680S-HMD64-ETN/-HMD66-ETN and V680-D1KP

Query	Communications time (ms) N: No. of bytes processed
Read	$T = 0.88N + 5.01$
Write(with verification)	$T = 1.69N + 3.01$
Write(without verification)	$T = 1.41N + 2.98$

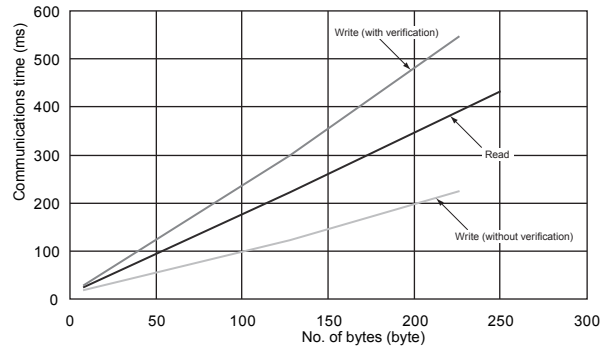

V680S-HMD64-ETN/-HMD66-ETN and V680-D8KF6

Query	Communications time (ms) N: No. of bytes processed
Read	$T = 0.84N + 5.05$
Write(with verification)	$T = 1.18N + 3.58$
Write(without verification)	$T = 0.91N + 3.55$

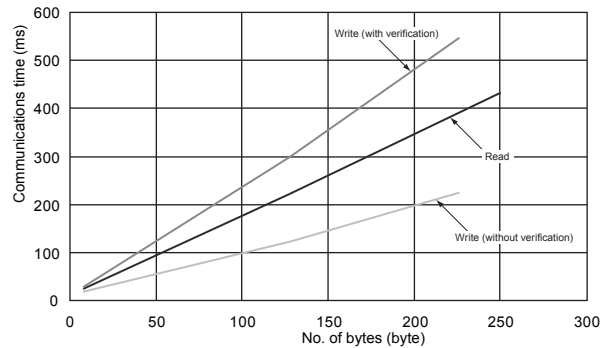

Travel Speed Calculations

When communicating with a moving RF Tag, specify an AUTO mode.

The maximum speed for communicating with the RF Tag can be calculated simply using the following formula.

$$\text{Maximum speed} = \frac{D \text{ (Distance travelled in communications area)}}{T \text{ (Communications time)}}$$

D (Distance travelled in communications area) is calculated from the actual measurement or the communications area between the Reader/Writer and RF Tag.

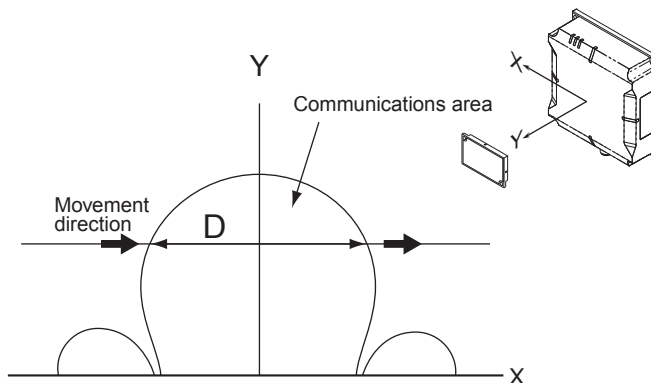

Calculation Example

The following example is for reading 128 bytes with the V680-D8KF68A, and V680S-HMD66-ETN.

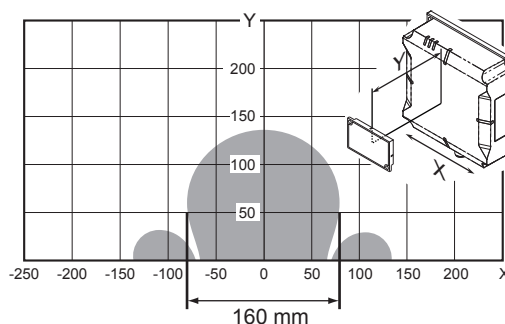

From the above chart,

Distance travelled in communications area = 160 mm when Y (communications distance) is 50 mm

Communications time T = 225.5 ms (calculated from the communications time, i.e., $1.2 \times 128 \text{ bytes} + 10.46$)

Therefore, the maximum speed of the Tag is as follows:

$$\begin{aligned} \text{Maximum speed} &= \frac{D \text{ (Distance travelled in communications area)}}{T \text{ (Communications time)}} = \frac{160(\text{mm})}{225.5(\text{ms})} \\ &= 42.57 \text{ m/min} \end{aligned}$$

Reader/Writer Installation Precautions

V680S-HMD64-ETN

■ Influence of Surrounding Metal on Reader/Writer (for Reference Only)

The Reader/Writer can be surface-mounted or it can be embedded in metal to protect it from collisions. If you embed the Reader/Writer in metal, separate it as least 100 mm from any metallic surface to prevent malfunctions. If the distance between surrounding metal and the Reader/Writer is less than 100 mm, the Reader/Writer communications distance will be greatly reduced. Do not allow the height of the metal to exceed the height of the Reader/Writer.

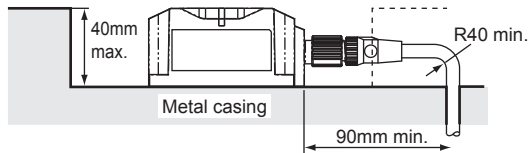

- Note**
1. Do not bend the cable into a curve tighter than 40 mm in radius.
 2. The communications distance will be reduced significantly if the Reader/Writer is installed closer than 100 mm to metal surfaces.

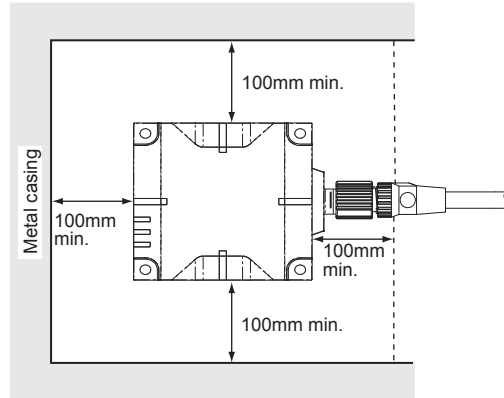

■ Mutual Interference of Reader/Writers (for Reference Only)

To prevent malfunctioning due to mutual interference when using more than one Reader/Writer, leave sufficient space between them as shown in the following diagrams.

If the distance between the Reader/Writers is too short, read / write distance will be reduced.

Model	Mounting distance	
	Installing the Reader/Writer Facing Each Other	Installing the Reader/Writer in Parallel
V680-D1KP54T	250mm	125mm
V680-D1KP66T	350mm	150mm
V680-D1KP66MT	250mm	150mm
V680-D1KP66T-SP	350mm	150mm
V680-D1KP58HTN	450mm	125mm
V680-D8KF67	300mm	105mm
V680-D8KF67M	200mm	95mm
V680-D8KF68A (horizontally)	550mm	150mm
V680-D8KF68A (Vertically)	450mm	150mm

• Installing the Reader/Writer Facing Each Other

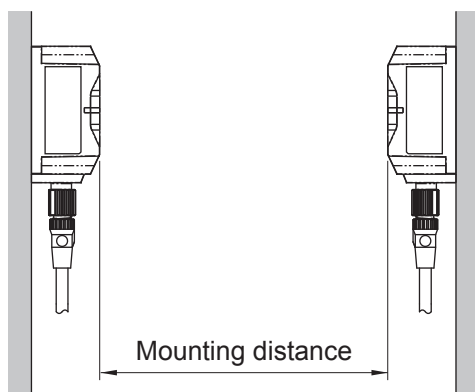

• Installing the Reader/Writer in Parallel

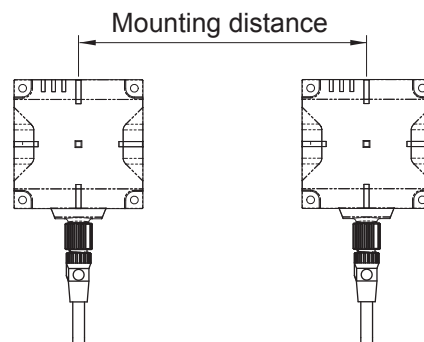

V680S-HMD66-ETN

■ Influence of Surrounding Metal on Reader/Writer (for Reference Only)

The Reader/Writer can be surface-mounted or it can be embedded in metal to protect it from collisions. If you embed the Reader/Writer in metal, separate it as least 160 mm from any metallic surface to prevent malfunctions. If the distance between surrounding metal and the Reader/Writer is less than 160 mm, the Reader/Writer communications distance will be greatly reduced. Do not allow the height of the metal to exceed the height of the Reader/Writer.

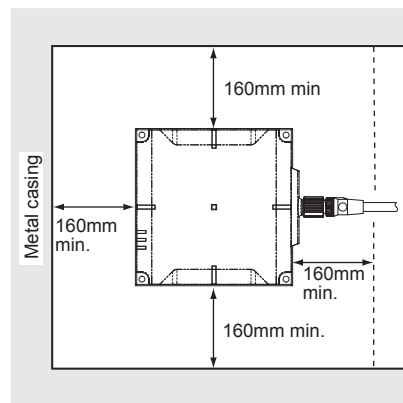
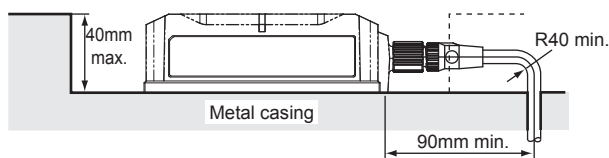

- Note**
1. Do not bend the cable into a curve tighter than 40 mm in radius.
 2. The communications distance will be reduced significantly if the Reader/Writer is installed closer than 160 mm to metal surfaces.

■ Mutual Interference of Reader/Writers (for Reference Only)

To prevent malfunctioning due to mutual interference when using more than one Reader/Writer, leave sufficient space between them as shown in the following diagrams.

If the distance between the Reader/Writers is too short, read / write distance will be reduced.

Model	Mounting distance	
	Installing the Reader/Writer Facing Each Other	Installing the Reader/Writer in Parallel
V680-D1KP54T	340mm	190mm
V680-D1KP66T	410mm	190mm
V680-D1KP66MT	300mm	180mm
V680-D1KP66T-SP	410mm	190mm
V680-D1KP58HTN	500mm	170mm
V680-D8KF67	360mm	150mm
V680-D8KF67M	280mm	160mm
V680-D8KF68A (horizontally)	510mm	180mm
V680-D8KF68A (Vertically)	500mm	170mm

• Reader/Writers Installed Facing Each Other

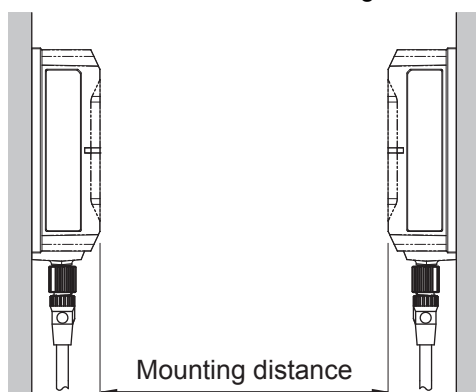

• Reader/Writers Installed in Parallel

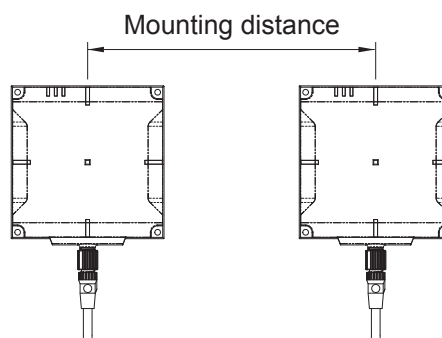

RF Tag Installation Precautions

V680-D1KP54T

Effect of Metal behind RF Tags

The communications distance will decrease if there is metal at the back of the V680-D1KP54T RF Tag. The V700-A80 Attachment is 8 mm thick. If the RF Tag is mounted on metallic material, use a non-metallic spacer (e.g., plastic or resin). The following graphs show the relationship between the distance from the RF Tag to the metallic surface and the communications distance.

The V700-A80 Attachment is 8 mm thick.

● V680S-HMD64-ETN and V680-D1KP54T

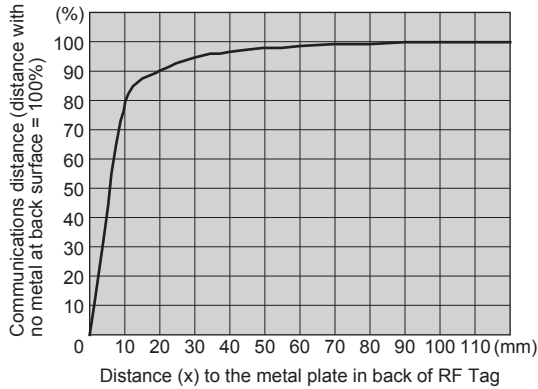

● V680S-HMD66-ETN and V680-D1KP54T

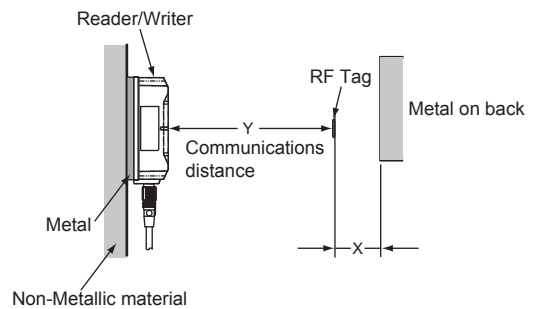
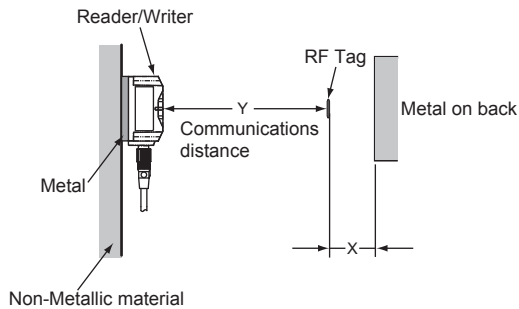
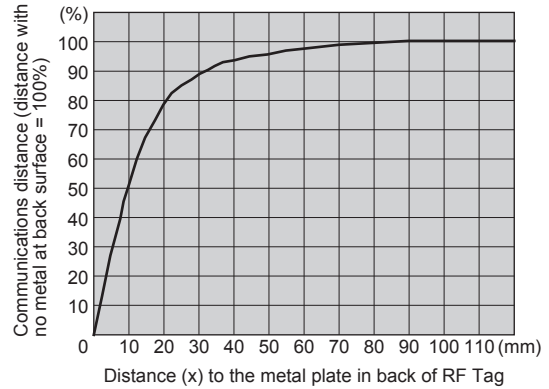

Mutual Interference of RF Tags

If you use more than one RF Tag, separate them by at least the interval shown below to prevent malfunctions due to mutual interference.

If the distance between the RF tags is too short, read / write distance will be reduced.

V680S-HMD64-ETN Reader/Writer

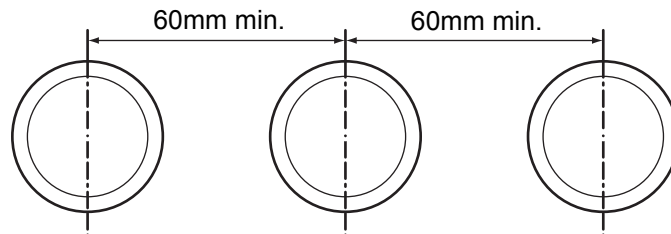

V680S-HMD66-ETN Reader/Writer

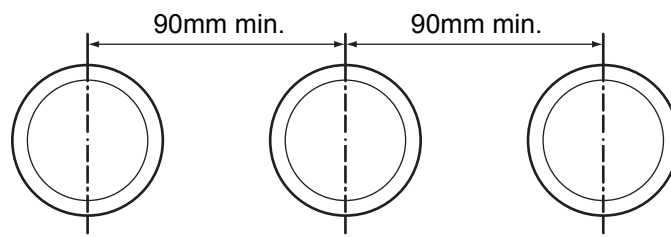

■ Influence of Inclination

Install the Reader/Writer and RF Tags so that the Reader/Writer and RF Tags are as parallel to each other as possible.

Communications will be possible even if the Reader/Writer and RF Tags are not parallel to each other; however, the communications distance is affected by the inclination between them as shown in the following graphs.

■ Rates of Change in Communications Distance for Inclination of V680-D1KP54T

	RF Tag inclination (θ°)									
	0	10	20	30	40	50	60	70	80	90
V680S-HMD64-ETN and V680-D1KP54T	0%	-1%	-3%	-6%	-12%	-19%	-29%	-43%	-70	---
V680S-HMD66-ETN and V680-D1KP54T	0%	-1%	-3%	-6%	-11%	-18%	-27%	-42%	-67	---

■ Measurement Conditions

- V680S-HMD64-ETN and V680-D1KP54T

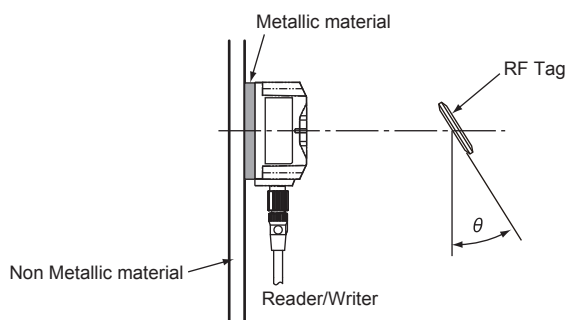

- V680S-HMD66-ETN and V680-D1KP54T

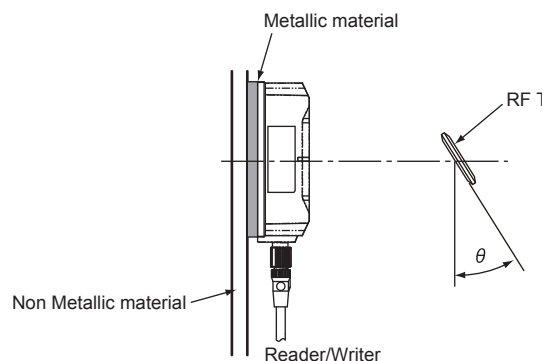

V680-D1KP66T

■ Influence of Metal at Back Surface

The communications distance will decrease if there is metal at the back of the V680-D1KP66T RF Tag. If the RF Tag is mounted on metallic material, use the V600-A86 Attachment (sold separately) or insert a non-metallic spacer (e.g., plastic or resin). The following graphs show the relationship between the distance from the RF Tag to the metallic surface and the communications distance.

You can also use more than one Attachment (10 mm).

Installation with the V600-A86 Attachment

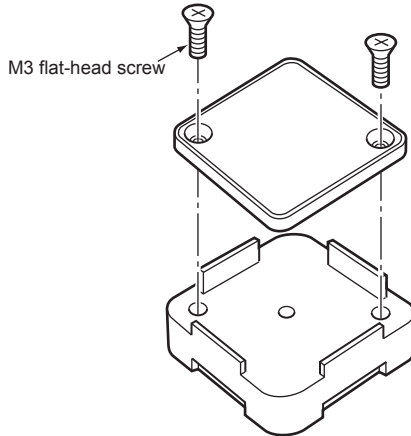

Orient the RF Tag so that the mounting holes are aligned.

● V680S-HMD64-ETN and V680-D1KP66T

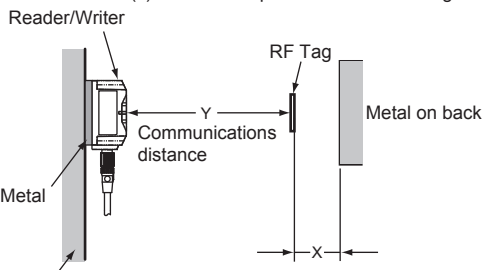
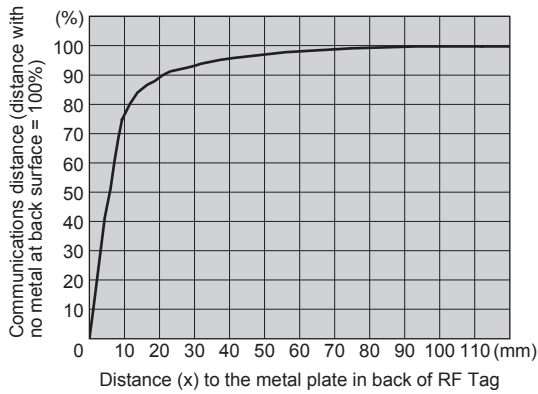

● V680S-HMD66-ETN and V680-D1KP66T

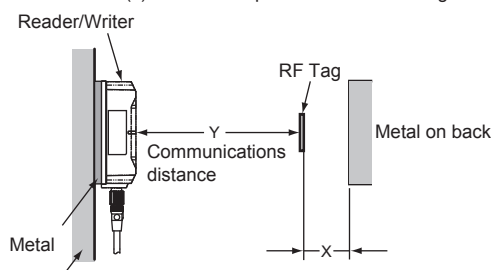
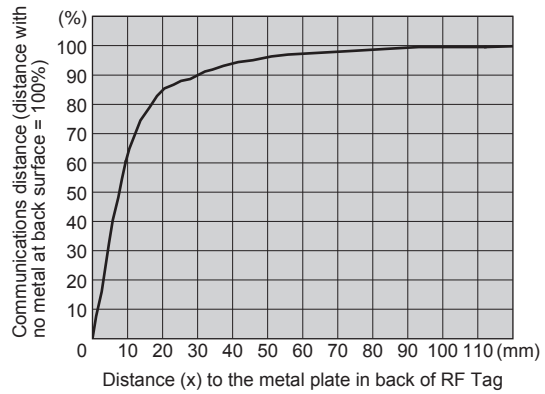

■ Mutual Interference of RF Tags

If you use more than one RF Tag, separate them by at least the interval shown below to prevent malfunctions due to mutual interference.

If the distance between the RF tags is too short, read / write distance will be reduced.

■ V680S-HMD64-ETN Reader/Writer

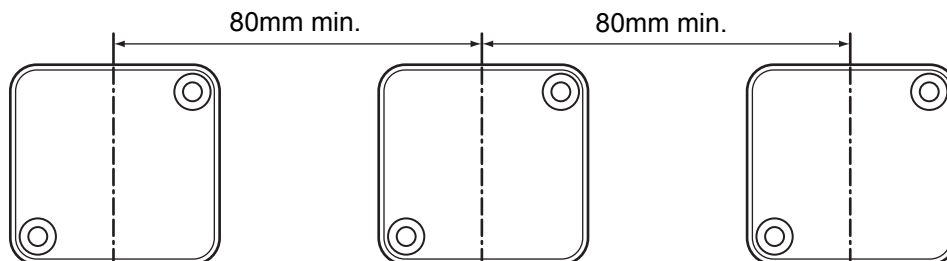

■ V680S-HMD66-ETN Reader/Writer

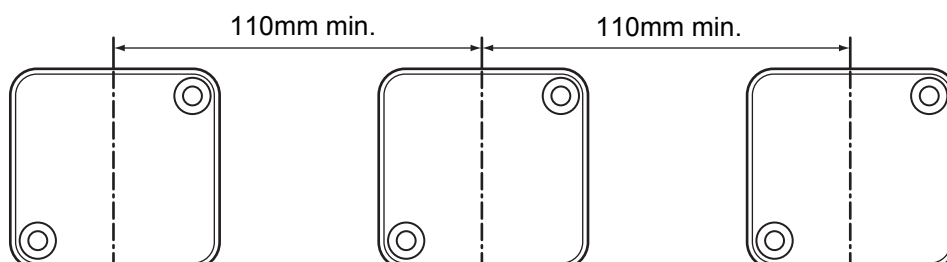

■ Influence of Inclination

Install the Reader/Writer and RF Tags so that the Reader/Writer and RF Tags are as parallel to each other as possible.

Communications will be possible even if the Reader/Writer and RF Tags are not parallel to each other; however, the communications distance is affected by the inclination between them as shown in the following graphs.

■ Rates of Change in Communications Distance for Inclination of V680-D1KP66T

	RF Tag inclination (θ°)									
	0	10	20	30	40	50	60	70	80	90
V680S-HMD64-ETN and V680-D1KP66T	0%	-1%	-3%	-5%	-9%	-14%	-21%	-32%	-48	---
V680S-HMD66-ETN and V680-D1KP66T	0%	-1%	-3%	-6%	-10%	-17%	-27%	-41%	-62	---

■ Measurement Conditions

- V680S-HMD64-ETN and V680-D1KP66T

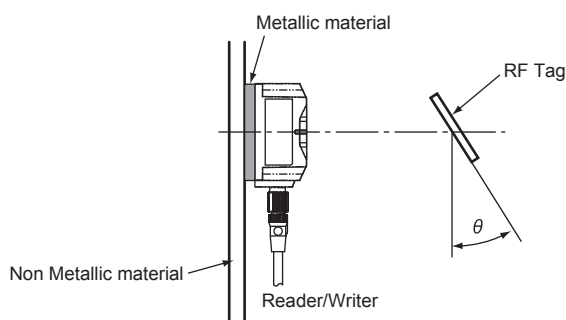

- V680S-HMD66-ETN and V680-D1KP66T

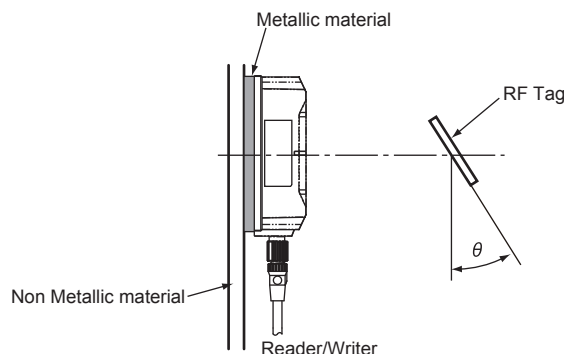

V680-D1KP66MT

■ Influence of Surrounding Metal

The V680-D1KP66MT can be surface-mounted or it can be embedded in metal. However, do not allow the height of the metal to exceed the height of the V680-D1KP66MT.

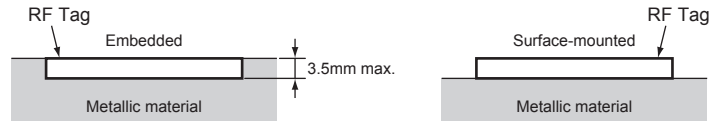

● V680S-HMD64-ETN and V680-D1KP66MT

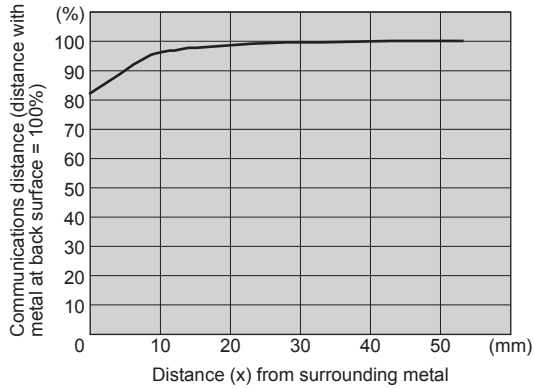

● V680S-HMD66-ETN and V680-D1KP66MT

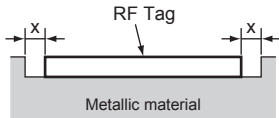
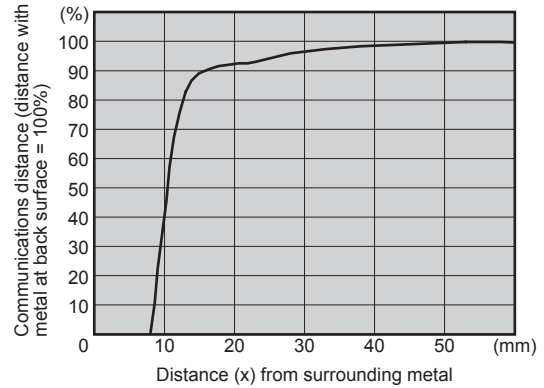

■ Mutual Interference of RF Tags

If you use more than one RF Tag, separate them by at least the interval shown below to prevent malfunctions due to mutual interference.

If the distance between the RF tags is too short, read / write distance will be reduced.

■ V680S-HMD64-ETN Reader/Writer

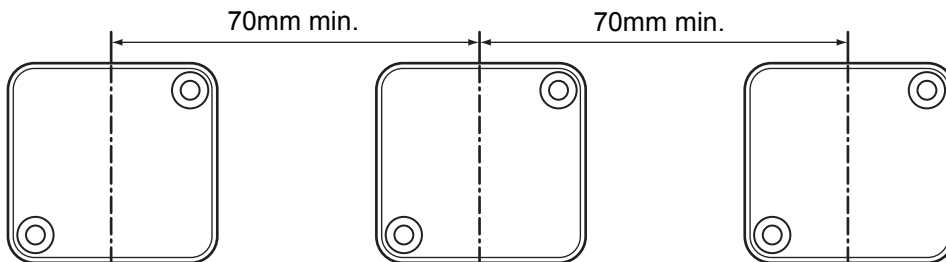

■ V680S-HMD66-ETN Reader/Writer

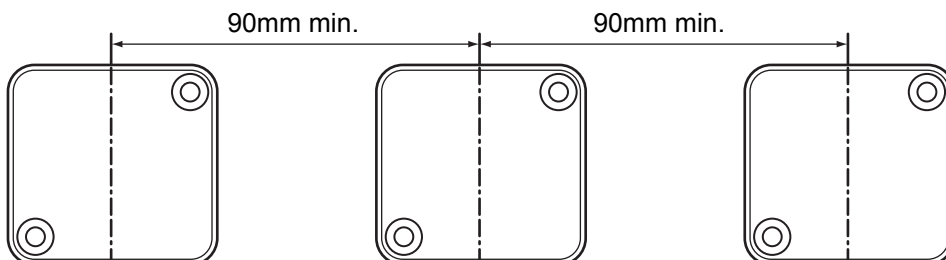

■ Influence of Inclination

Install the Reader/Writer and RF Tags so that the Reader/Writer and RF Tags are as parallel to each other as possible.

Communications will be possible even if the Reader/Writer and RF Tags are not parallel to each other; however, the communications distance is affected by the inclination between them as shown in the following graphs.

■ Rates of Change in Communications Distance for Inclination of V680-D1KP66MT

	RF Tag inclination (θ°)									
	0	10	20	30	40	50	60	70	80	90
V680S-HMD64-ETN and V680-D1KP66MT (Metal at back surface: Steel)	0%	0%	-2%	-5%	-10%	-18%	-31%	-59%	---	---
V680S-HMD66-ETN and V680-D1KP66MT (Metal at back surface: Steel)	0%	0%	-3%	-7%	-16%	-28%	-49%	---	---	---

■ Measurement Conditions

- V680S-HMD64-ETN and V680-D1KP66MT
(Metal at Back Surface: Steel)

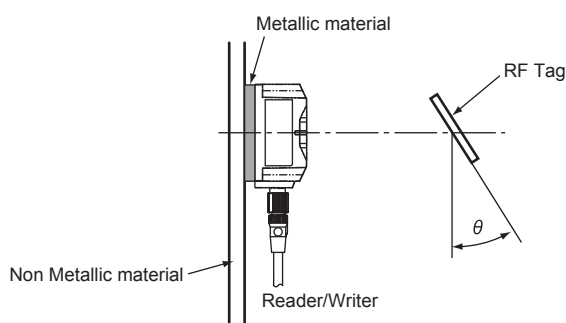

- V680S-HMD66-ETN and V680-D1KP66MT
(Metal at Back Surface: Steel)

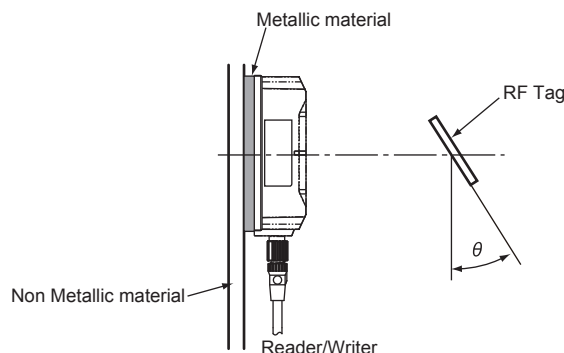

V680-D1KP66T-SP

■ Influence of Metal at Back Surface

The communications distance will decrease if there is metal at the back of the V680-D1KP66T-SP RF Tag. If the RF Tag is mounted on metallic material, use a non-metallic spacer (e.g., plastic or resin). The following graphs show the relationship between the distance from the RF Tag to the metallic surface and the communications distance.

● V680S-HMD64-ETN and V680-D1KP66T-SP

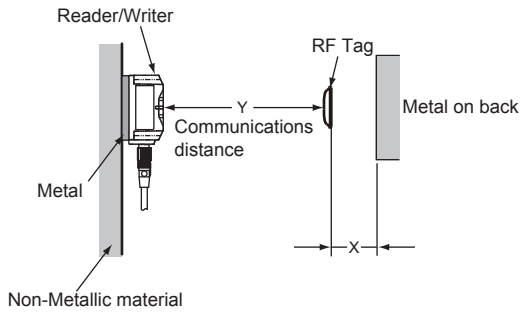
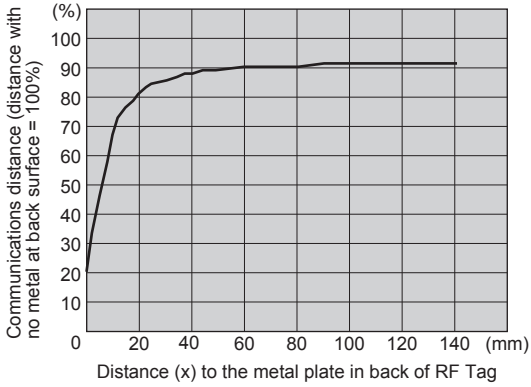

● V680S-HMD66-ETN and V680-D1KP66T-SP

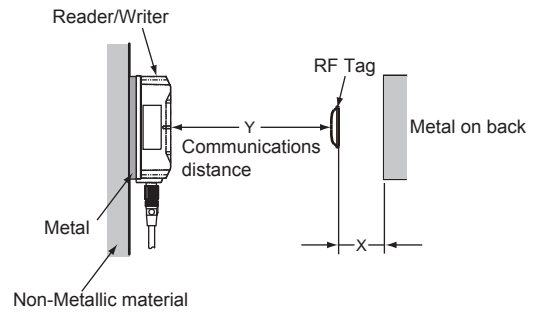
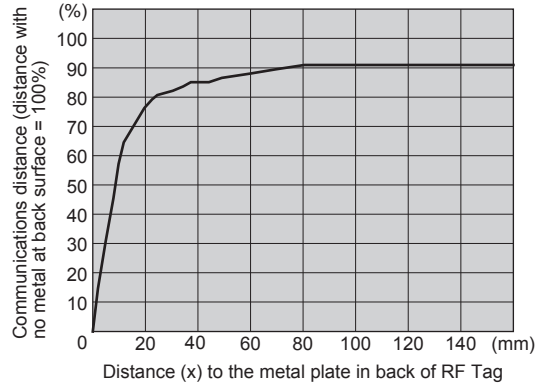

■ Mutual Interference of RF Tags

If you use more than one RF Tag, separate them by at least the interval shown below to prevent malfunctions due to mutual interference.

If the distance between the RF tags is too short, read / write distance will be reduced.

■ V680S-HMD64-ETN Reader/Writer

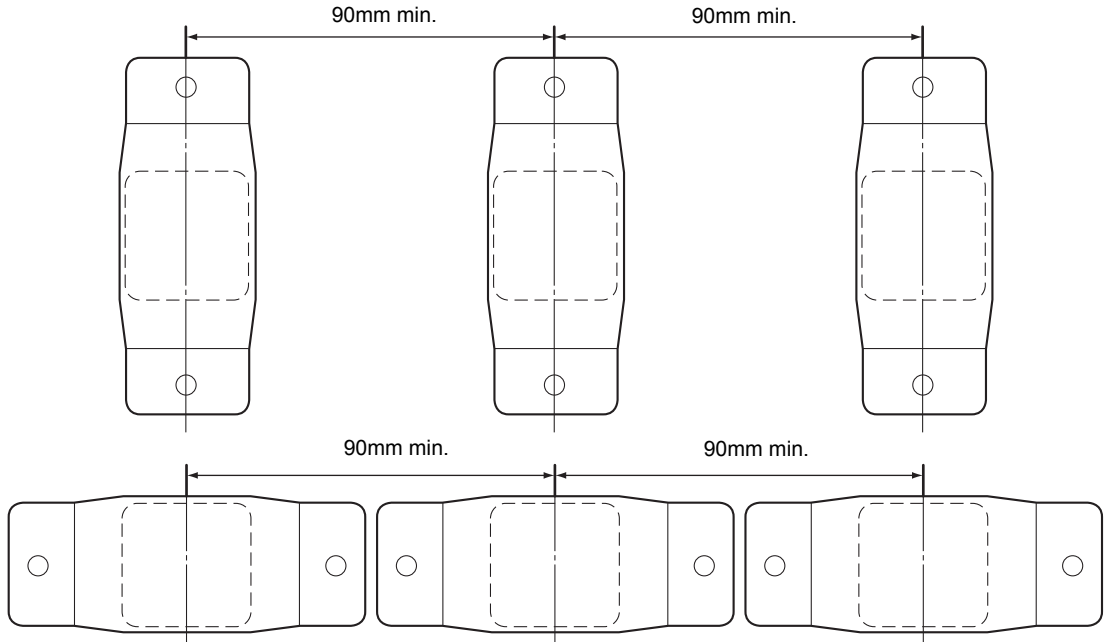

V680S-HMD66-ETN Reader/Writer

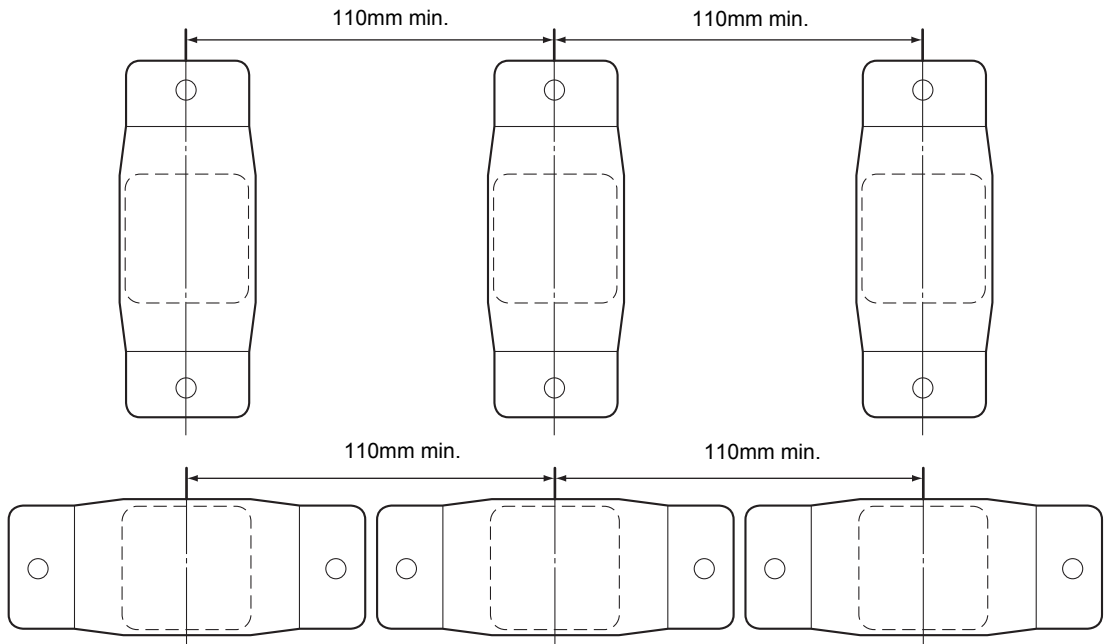

■ **Influence of Inclination**

Install the Reader/Writer and RF Tags so that the Reader/Writer and RF Tags are as parallel to each other as possible.

Communications will be possible even if the Reader/Writer and RF Tags are not parallel to each other; however, the communications distance is affected by the inclination between them as shown in the following graphs.

■ **Rates of Change in Communications Distance for Inclination of V680-D1KP66T-SP**

	RF Tag inclination (θ°)									
	0	10	20	30	40	50	60	70	80	90
V680S-HMD64-ETN and V680-D1KP66T-SP	0%	-1%	-3%	-5%	-9%	-14%	-21%	-32%	-48%	---
V680S-HMD66-ETN and V680-D1KP66T-SP	0%	-1%	-3%	-6%	-10%	-17%	-27%	-41%	-62%	---

■ **Measurement Conditions**

- V680S-HMD64-ETN and V680-D1KP66T-SP

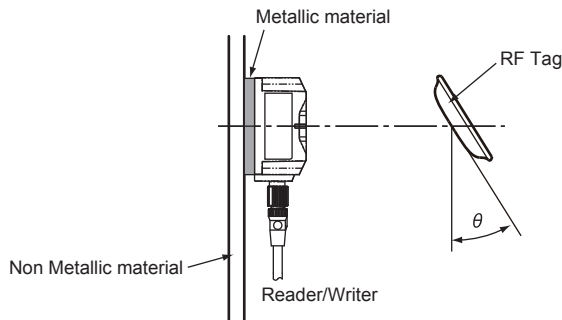

- V680S-HMD66-ETN and V680-D1KP66T-SP

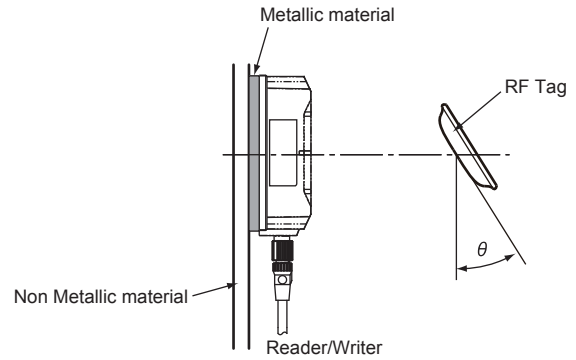

V680-D1KP58HTN

■ Influence of Metal at Back Surface

You must consider the influence of the mounting location when mounting RF Tags.

The communications distance of an RF Tag may be reduced by the influence of the surrounding objects. The amount that the communications distance decreases will depend on the materials and shapes of the surrounding objects. As reference data, this section shows the influence of metal at the back surface of an RF Tag.

■ Influence of Metal Objects

The following figure shows the percentage of decrease in the communications distance when there is a metal object at the back surface of an RF Tag.

The X axis gives the distance between the RF Tag and a metal plate. The Y axis shows the relative communications distance taking the communications distance with no metal plate as 100% (i.e., it shows the percentage of decrease in the communications distance).

● V680S-HMD64-ETN and V680-D1KP58HTN

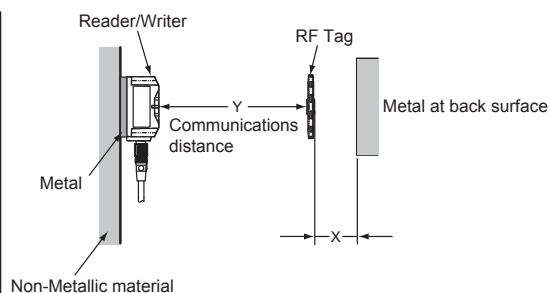
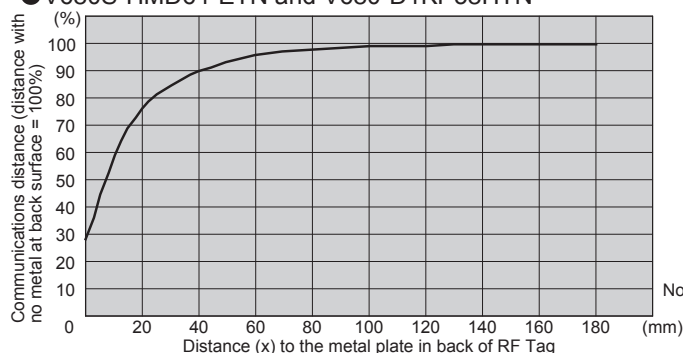

● V680S-HMD66-ETN and V680-D1KP58HTN

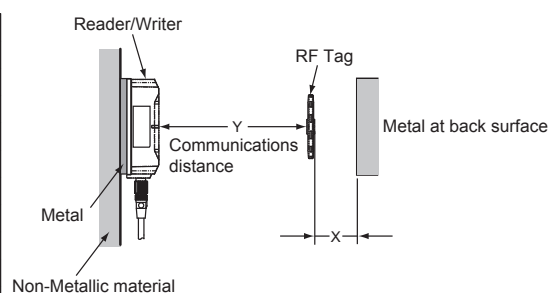
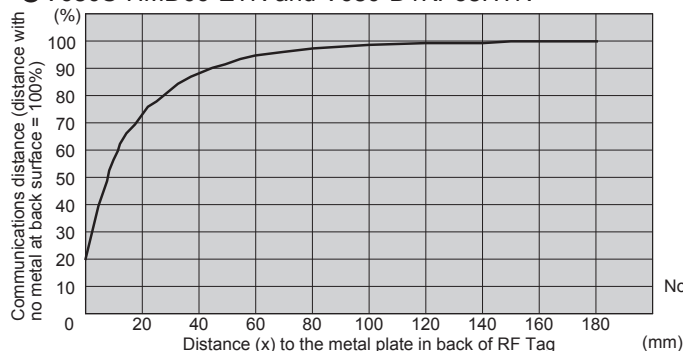

Material: Steel (thickness: 1.5 mm)

Shape: 295 × 295 mm

■ Mutual Interference of RF Tags

If you use more than one RF Tag, separate them by at least the interval shown below to prevent malfunctions due to mutual interference.

If the distance between the RF tags is too short, read / write distance will be reduced.

■ V680S-HMD64-ETN Reader/Writer

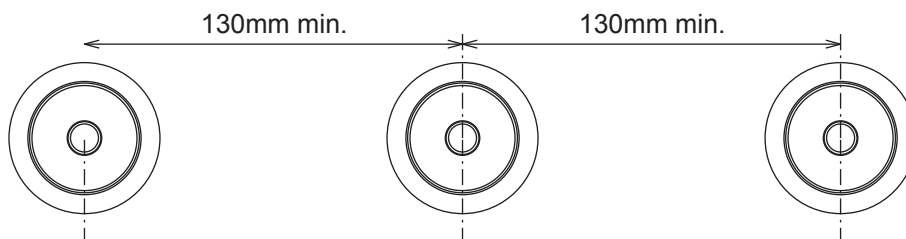

■ V680S-HMD66-ETN Reader/Writer

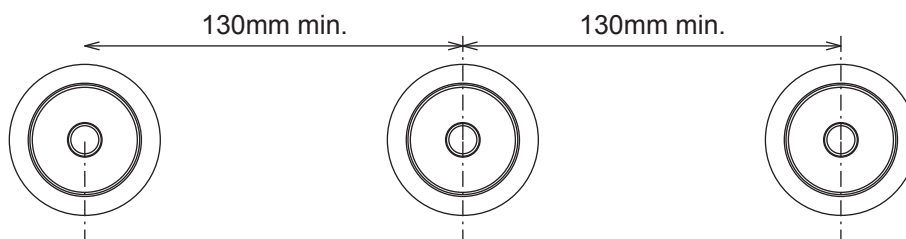

■ Influence of Inclination

The maximum communications distance is achieved when the RF Tags are mounted so that the surfaces of the RF Tags are parallel with the surface of the Reader/Writer. If the RF Tags are mounted at an angle, the communications distance will decrease. You must consider the influence of the inclination of the RF Tags when mounting RF Tags.

As reference data, this section shows the decrease in the communications distance due to RF Tag inclination.

The X axis gives the angle with 0° which indicates that the RF Tag and Reader/Writer surfaces are parallel to each other. The Y axis shows the relative communications distance taking the communications distance at 0° as 100% (i.e., it shows the percentage of decrease in the communications distance).

■ Rates of Change in Communications Distance for Inclination of V680-D1KP58HTN

	RF Tag inclination (θ°)									
	0	10	20	30	40	50	60	70	80	90
V680S-HMD64-ETN and V680-D1KP58HTN	0%	-1%	-3%	-5%	-8%	-14%	-22%	-32%	-35%	---
V680S-HMD66-ETN and V680-D1KP58HTN	0%	-1%	-2%	-4%	-7%	-11%	-17%	-27%	-44%	---

■ Measurement Conditions

- V680S-HMD64-ETN and V680-D1KP58HTN

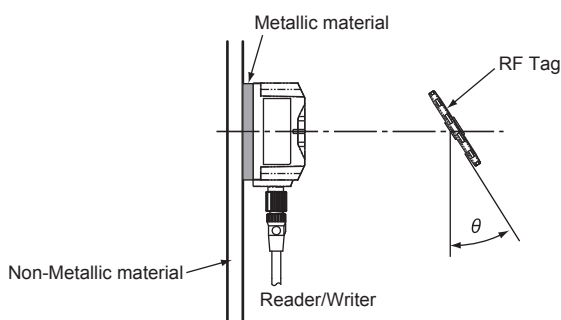

- V680S-HMD66-ETN and V680-D1KP58HTN

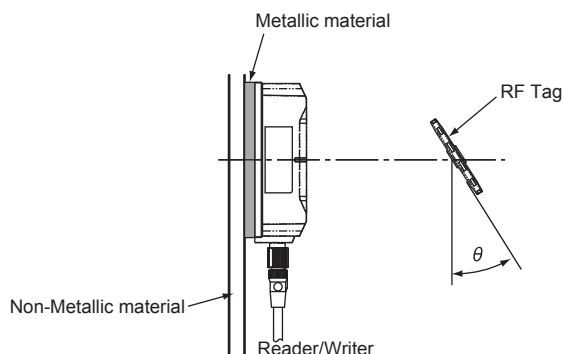

V680-D8KF67

■ Influence of Metal at Back Surface of RF Tags

The communications distance will decrease if there is metal at the back of the V680-D1KP66T-SP RF Tag. If the RF Tag is mounted on metallic material, use a non-metallic spacer (e.g., plastic or resin). The following graphs show the relationship between the distance from the RF Tag to the metallic surface and the communications distance.

● V680S-HMD64-ETN and V680-D8KF67

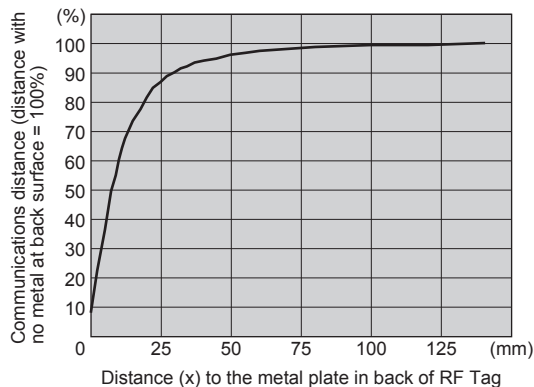

● V680S-HMD66-ETN and V680-D8KF67

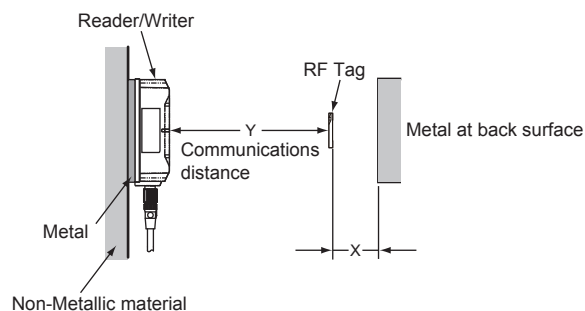
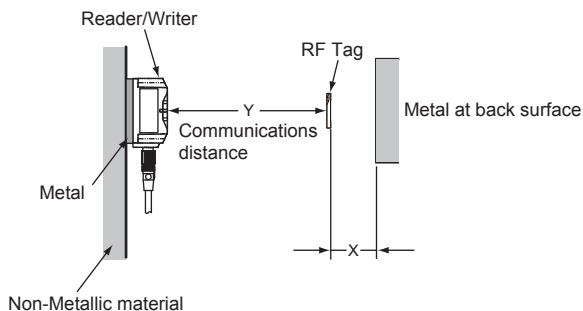
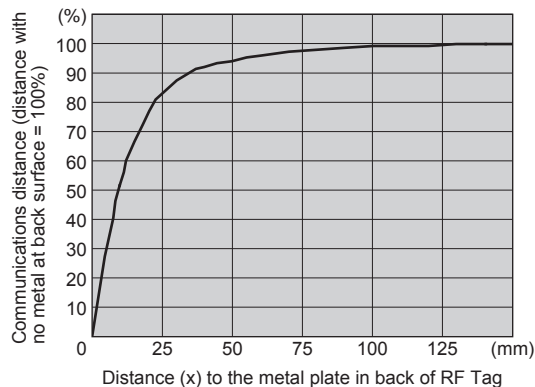

■ Mutual Interference of RF Tags

If you use more than one RF Tag, separate them by at least the interval shown below to prevent malfunctions due to mutual interference.

If the distance between the RF tags is too short, read / write distance will be reduced.

■ V680S-HMD64-ETN Reader/Writer

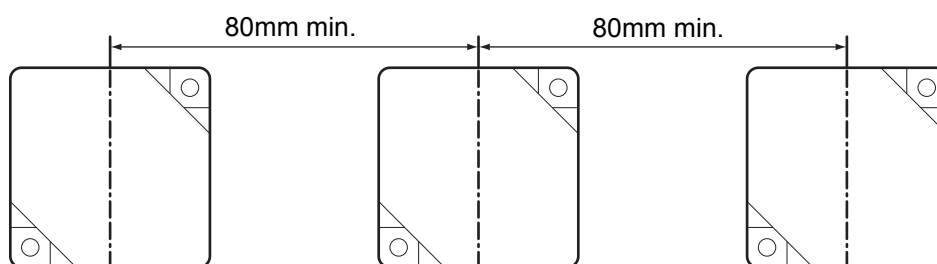

■ V680S-HMD66-ETN Reader/Writer

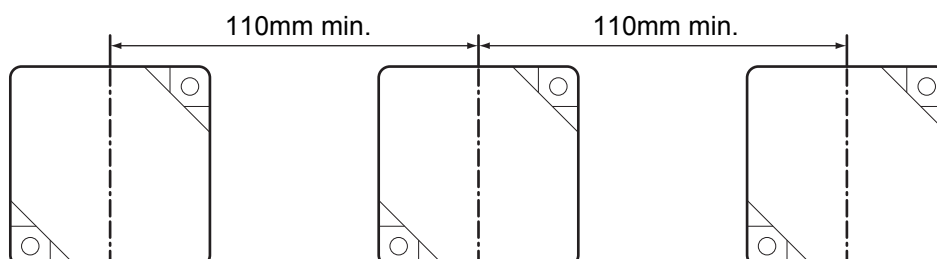

■ Influence of Inclination

Install the Reader/Writer and RF Tags so that the Reader/Writer and RF Tags are as parallel to each other as possible.

Communications will be possible even if the Reader/Writer and RF Tags are not parallel to each other; however, the communications distance is affected by the inclination between them as shown in the following graphs.

■ Rates of Change in Communications Distance for Inclination of V680-D8KF67

	RF Tag inclination (θ°)									
	0	10	20	30	40	50	60	70	80	90
V680S-HMD64-ETN and V680-D8KF67	0%	0%	-1%	-2%	-3%	-7%	-13%	-21%	-34%	-59%
V680S-HMD66-ETN and V680-D8KF67	0%	-1%	-3%	-6%	-10%	-15%	-24%	-34%	-53%	---%

■ Measurement Conditions

- V680S-HMD64-ETN and V680-D18KF67

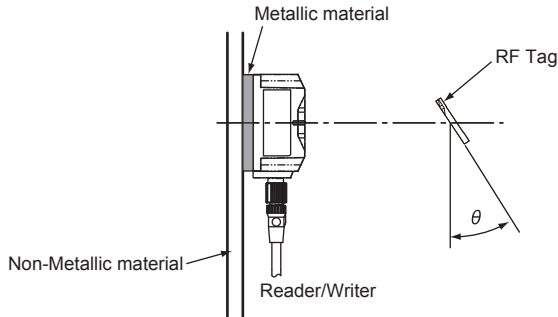

- V680S-HMD66-ETN and V680-D8KF67

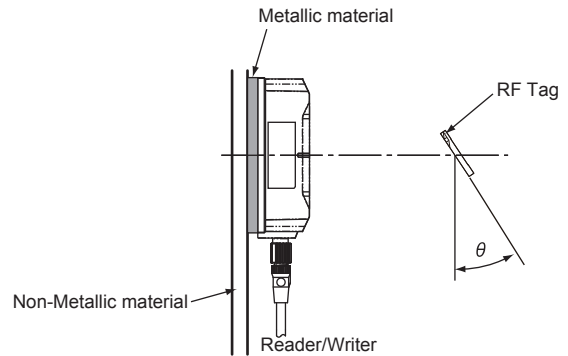

V680-D8KF67M

■ Influence of Surrounding Metal

The V680-D8KF67M can be surface-mounted or it can be embedded in metal. However, do not allow the height of the metal to exceed the height of the V680-D8KF67M.

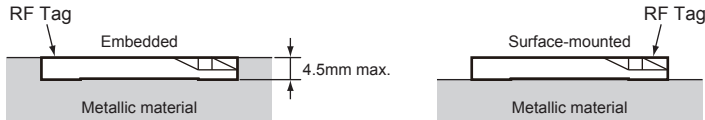

● V680S-HMD64-ETN and V680-D8KF67M

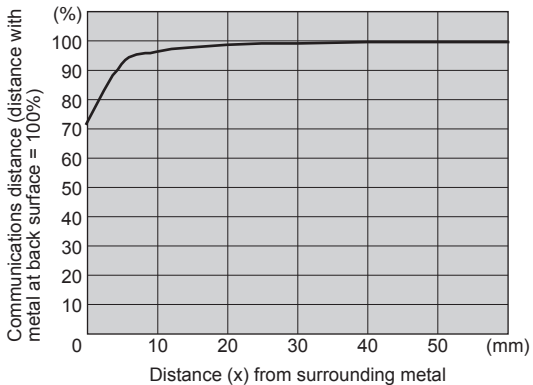

● V680S-HMD66-ETN and V680-D8KF67M

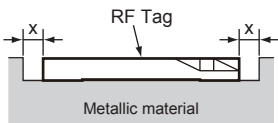
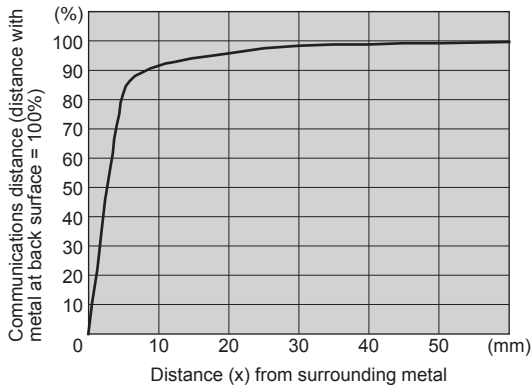

■ Mutual Interference of RF Tags

If you use more than one RF Tag, separate them by at least the interval shown below to prevent malfunctions due to mutual interference.

If the distance between the RF tags is too short, read / write distance will be reduced.

■ V680S-HMD64-ETN Reader/Writer

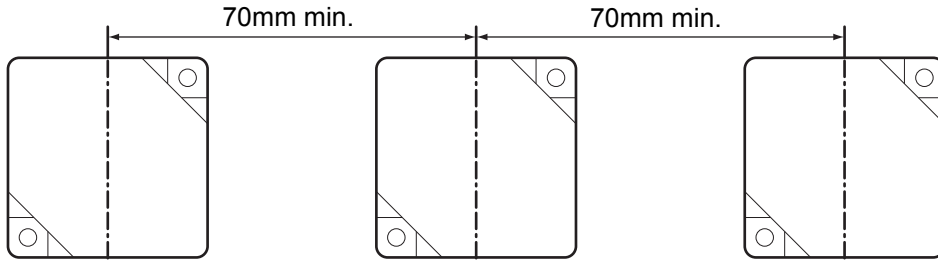

■ V680S-HMD66-ETN Reader/Writer

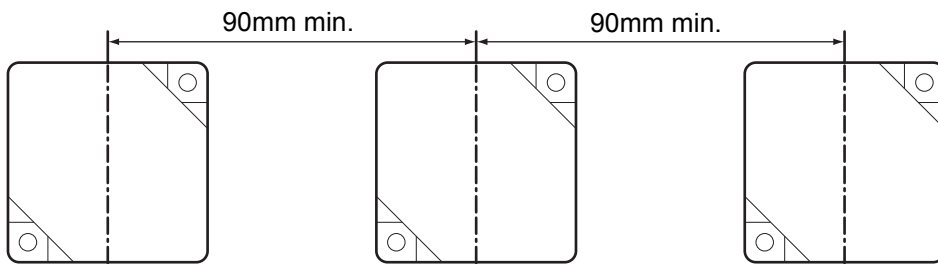

■ Influence of Inclination

Install the Reader/Writer and RF Tags so that the Reader/Writer and RF Tags are as parallel to each other as possible.

Communications will be possible even if the Reader/Writer and RF Tags are not parallel to each other; however, the communications distance is affected by the inclination between them as shown in the following graphs.

■ Rates of Change in Communications Distance for Inclination of V680-D8KF67M

	RF Tag inclination (θ°)									
	0	10	20	30	40	50	60	70	80	90
V680S-HMD64-ETN and V680-D8KF67M (Metal at back surface: Steel)	0%	-1%	-3%	-7%	-12%	-20%	-33%	-56%	---%	---%
V680S-HMD66-ETN and V680-D8KF67M (Metal at back surface: Steel)	0%	-1%	-4%	-8%	-15%	-26%	-41%	-66%	---%	---%

■ Measurement Conditions

- V680S-HMD64-ETN and V680-D18KF67M
(Metal at Back Surface: Steel)

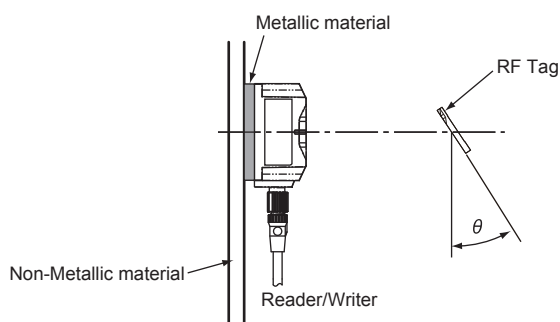

- V680S-HMD66-ETN and V680-D8KF67M
(Metal at Back Surface: Steel)

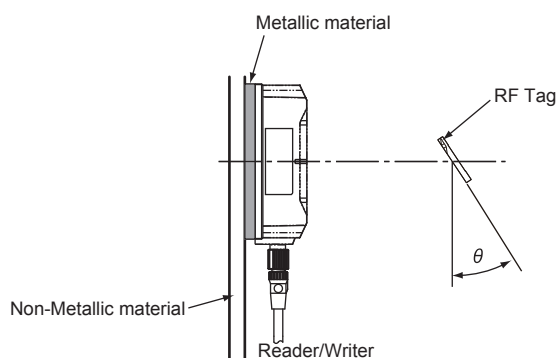

V680-D8KF68A

■ Influence of Metal at Back Surface of RF Tags

The communications distance will decrease if there is metal at the back of the V680-D1KP68A RF Tag. If the RF Tag is mounted on metallic material, use a non-metallic spacer (e.g., plastic or resin). The following graphs show the relationship between the distance from the RF Tag to the metallic surface and the communications distance.

● V680S-HMD64-ETN and V680-D8KF68A

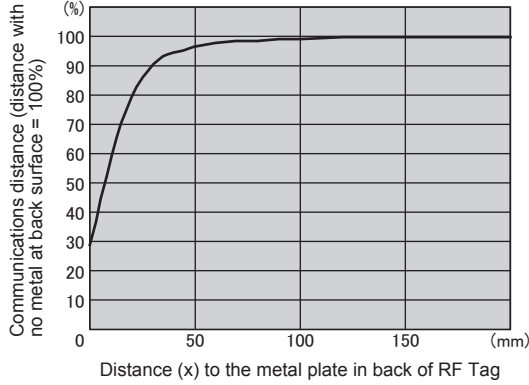

● V680S-HMD66-ETN and V680-D8KF68A

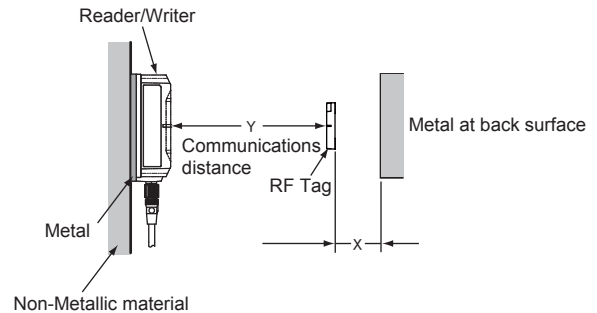
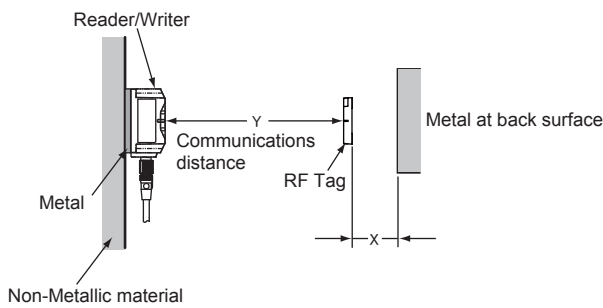
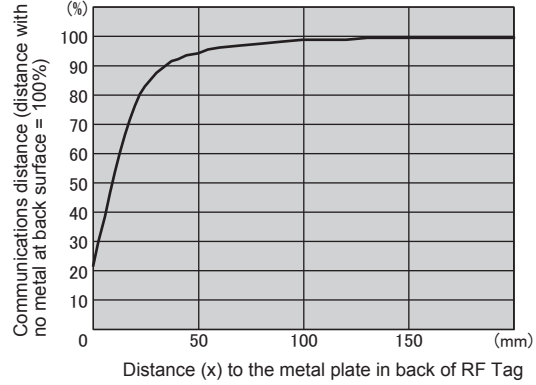

■ **Mutual Interference of RF Tags**

If you use more than one RF Tag, separate them by at least the interval shown below to prevent malfunctions due to mutual interference.

If the distance between the RF tags is too short, read / write distance will be reduced.

■ **V680S-HMD64-ETN Reader/Writer**

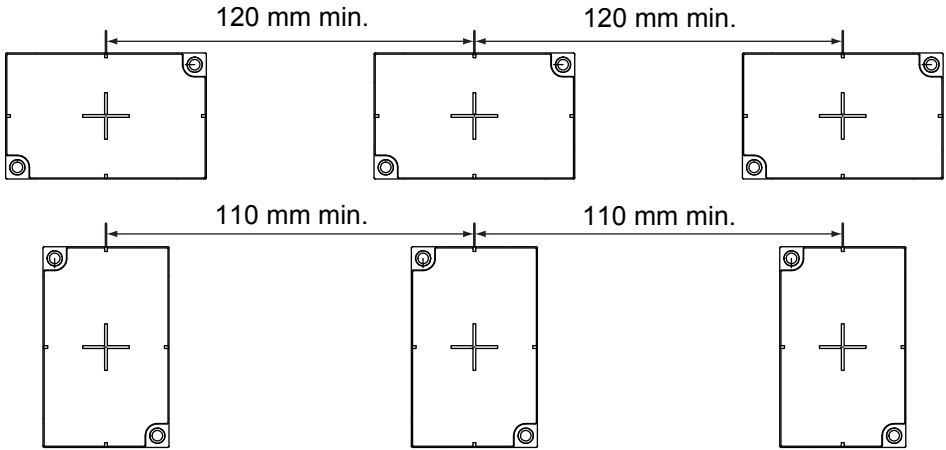

■ **V680S-HMD66-ETN Reader/Writer**

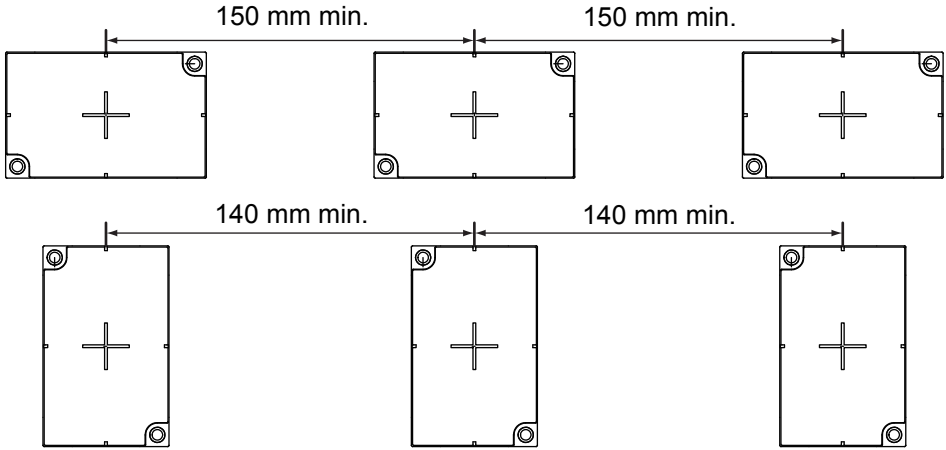

■ **Influence of Inclination (for Reference Only)**

Install the Reader/Writer and RF Tags so that the Reader/Writer and RF Tags are as parallel to each other as possible.

Communications will be possible even if the Reader/Writer and RF Tags are not parallel to each other; however, the communications distance is affected by the inclination between them as shown in the following graphs.

■ **Rates of Change in Communications Distance for Inclination of V680-D8KF68A**

	RF Tag inclination (θ°)									
	0	10	20	30	40	50	60	70	80	90
V680S-HMD64-ETN and V680-D8KF68A horizontally	0%	-1%	-2%	-5%	-8%	-14%	-21%	-30%	-47%	---
V680S-HMD64-ETN and V680-D8KF68A vertically	0%	-1%	-1%	-3%	-5%	-8%	-13%	-21%	-35%	---
V680S-HMD66-ETN and V680-D8KF68A horizontally	0%	-1%	-2%	-4%	-7%	-11%	-17%	-27%	-41%	---
V680S-HMD66-ETN and V680-D8KF68A vertically	0%	-1%	-2%	-5%	-8%	-14%	-20%	-31%	-48%	---

■ **Measurement Conditions**

- V680S-HMD64-ETN and V680-D8KF68A

horizontally

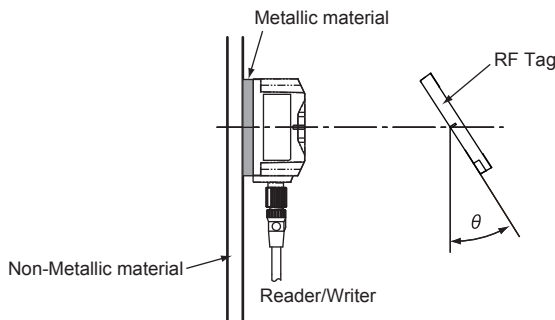

- V680S-HMD64-ETN and V680-D8KF68A

vertically

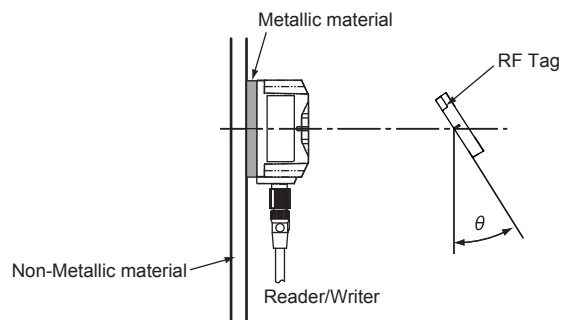

- V680S-HMD66-ETN and V680-D8KF68A

horizontally

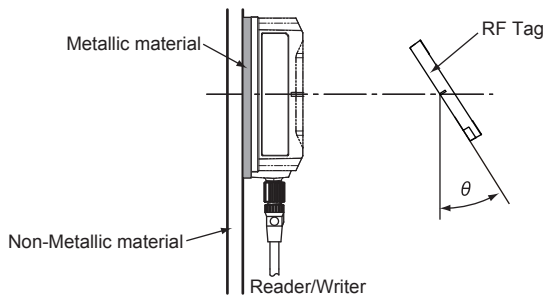

- V680S-HMD66-ETN and V680-D8KF68A

vertically

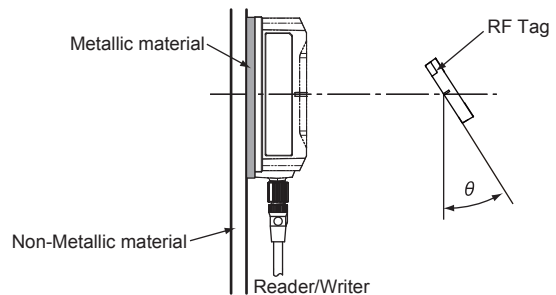

RF Tag Memory Capacities and Memory Types

(As of April 2013)

Model	Memory capacity (user memory)	Memory type	Life expectancy
V680-D1KP54T V680-D1KP66T V680-D1KP66MT V680-D1KP66T-SP	1,000 bytes	EEPROM	<ul style="list-style-type: none"> • Overwrite operations: 100,000 times for each address at 25°C • Data retention: 10 years (at 85°C)
V680-D1KP58HTN			<ul style="list-style-type: none"> • Overwrite operations: 100,000 times for each address at 25°C • Data retention: 10 years (at 85°C) * Total data retention at high temperatures exceeding 125°C is 10 hours
V680-D8KF67 V680-D8KF67M V680-D8KF68A	8,192 bytes	FRAM	<ul style="list-style-type: none"> • Number of accesses: 10 billion • Data retention: 10 years (at 55°C)

RF Tag Memory Map

V680-D1KP□□ RF Tags

Block	Address(W)	Data	
0	0000 hex	} User area	
	0001 hex		
	0002 hex		
	0003 hex		
1	0004 hex		
	0005 hex		
	0006 hex		
	0007 hex		
⋮	⋮		
⋮	⋮		
123	01EC hex		
	01ED hex		
	01EE hex		
	01EF hex		
124	01F0 hex		
	01F1 hex		
	01F2 hex		
	01F3 hex		

← 1 word →

EEPROM is used as the memory in the RF Tag.
The user-accessible capacity is 1,000 bytes.

V680-D8KF6 RF Tags

Sector	Block	Address(W)	Data
0	0	0000 hex	}-----
		0001 hex	
		0002 hex	
		0003 hex	
	1	0004 hex	
		0005 hex	
		0006 hex	
		0007 hex	
	⋮	⋮	
		⋮	
	254	03F8 hex	
		03F9 hex	
		03FA hex	
		03FB hex	
	255	03FC hex	
		03FD hex	
03FE hex			
03FF hex			
⋮	⋮		
	⋮		
3	768	0C00 hex	}-----
		0C01 hex	
		0C02 hex	
		0C03 hex	
	769	0C04 hex	
		0C05 hex	
		0C06 hex	
		0C07 hex	
	⋮	⋮	
		⋮	
	1,022	0FF8 hex	
		0FF9 hex	
		0FFA hex	
		0FFB hex	
	1,023	0FFC hex	
		0FFD hex	
		0FFE hex	
		0FFF hex	

User area

FRAM is used as the memory in the RF Tag.
The user-accessible capacity is 8,192 bytes.

1 word

Chemical Resistance of the Reader/Writers and RF Tags

Chemical Resistance of the Reader/Writers

■ Applicable Models

V680S-HMD64-ETN/-HMD66-ETN

The chemicals that affect the Reader/Writer are listed below.

PBT (polybutylene terephthalate) is used as the case material and a urethane resin is used as the filling. Refer to the following lists and do not use chemicals that affect PBT and urethane resins.

Reader/Writers cannot be used in applications with explosion-proof specifications.

■ Chemicals That Cause Deformations, Cracks, Etc.

Chemical name
Acetone, trichloroethylene, ethylene dichloride, sodium hydroxide, and other alkaline substances, hydrochloric acid (35% or more), nitric acid (70% or more)

■ Chemicals That May Cause Discoloration, Swelling, Etc.

Chemical name
Hydrochloric acid (10% RT), acetic acid (5% RT), benzene, nitric acid (20% or more)

Note: The above results are from tests conducted at room temperature (23°C). Even if the chemicals do not affect the PPS or epoxy resins at room temperature, they may affect the resins at higher or lower temperatures. Check the chemicals carefully in advance.

■ Applicable Models

V680-D1KP54T/-D1KP66T/-D1KP66MT/-D1KP58HTN

PPS resin is used for case material. Refer to the following lists and do not use chemicals that affect PPS and epoxy resin.

RF Tags cannot be used in applications with explosion-proof specifications.

Chemical		At room temperature	At 90°C
Hydrochloric acid	37%	A	A
	10%	A	A
Sulfuric acid	98%	A	B
	50%	A	A
	30%	A	A
	3%	A	A
Nitric acid	60%	B	C
	40%	A	B
	10%	A	A
Hydrogen fluoride solution	40%	B	B
Chromic acid	40%	A	A
Hydrogen peroxide solution	28%	A	B
	3%	A	A
Sodium hydroxide solution	60%	A	A
	10%	A	A
	1%	A	A
Ammonia solution	28%	A	B
	10%	A	B
Sodium chloride	10%	A	A
Sodium carbonate	20%	A	A
	2%	A	A

Chemical		At room temperature	At 90°C
Sodium hypochlorite		A	A
Phenol solution	5%	A	A
Glacial acetic acid		A	A
Acetic acid		A	A
Oleic acid		A	A
Methyl alcohol	95%	A	A
Ethyl alcohol	95%	A	A
Ethyl acetate		A	A
Sebacic acid diethylhexyl		A	A
Acetone		A	A
Diethyl ether		A	A
n-heptane		A	A
2-2-4 trimethylpentane		A	A
Benzene		A	A
Toluene		A	A
Aniline		A	A
Mineral oil		A	A
Gasoline		A	A
Insulating oil		A	A
Dichloroethylene		A	A
Carbon tetrachloride		A	A

A: Has no adverse effect, B: May cause discoloration, swelling, etc., C: Causes deformation, cracks, etc.



The above table shows the extent of changes in PPS resin exposed to each chemical at room temperature and at 90°C. If actual chemicals, concentrations, and temperatures are different from those shown in the tables, always conduct tests under the actual conditions in which the RF Tags are to be used.

■ **Applicable Models**

V680-D8KF67/-D8KF67M/-D8KF68A

Chemicals that affect RF Tags are shown below.

Polybutylene terephthalate (PBT) resin is used for case material and epoxy resin for filling material.

Refer to the following lists and do not use chemicals that affect PBT and epoxy resins.

RF Tags cannot be used in applications with explosion-proof specifications.

■ **Chemicals That Cause Deformations, Cracks, Etc.**

PBT resin	Epoxy resin
Acetone, trichloroethylene, ethylene dichloride, sodium hydroxide, and other alkaline substances	Aqua regia, chromic acid, sulfuric acid (90% RT), nitric acid (60% RT), liquid ammonia, acetone, methylene chloride, phenol

■ **Chemicals That May Cause Discoloration, Swelling, Etc.**

PBT resin	Epoxy resin
Hydrochloric acid (10% RT), acetic acid (5% RT), benzene	Sulfuric acid (10% RT), nitric acid (10% RT), concentrated hydrochloric acid, acetic acid (50% RT), oxalic acid, calcium hydroxide, benzene, cresol, alcohol, microhexanon, toluene, xylene, benzene, grease

■ **Chemicals that Do Not Affect PPS Resin or Epoxy Resin**

PBT resin	Epoxy resin
Nitric acid (30% RT), concentrated hydrochloric acid, acetic acid, ethyl acetate (100% RT), potassium permanganate (5% RH), ethyl acetate, carbon tetrachloride, methanol, ethanol, gasoline	Ammonia, hydrochloric acid (10% RT), potassium hydrate, petroleum, gasoline, Yushiroken S50, Chemi-cool Z, Velocity No. 3, Yushiroken EEE-30Y, methyl ethyl ketone, sodium hydroxide (10% RH)

Note: The above results are from tests conducted at room temperature (23°C). Even if the chemicals do not affect the PPS or epoxy resins at room temperature, they may affect the resins at higher or lower temperatures. Check the chemicals carefully in advance.

Degree of Protection

Ingress protection degrees (IP-□□) are determined by the following tests. Be sure to check the sealing capability under the actual operating environment and conditions before actual use.

■ IEC (International Electrotechnical Commission)

IEC 60529:1989-11

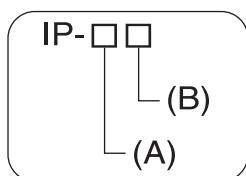







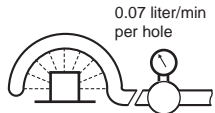

(A) First Digit: Degree of Protection from Solid Materials

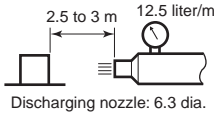
Degree	Protection	
0		No protection
1		Protects against penetration of any solid object such as a hand that is 50 mm or more in diameter.
2		Protects against penetration of any solid object, that is 12.5 mm or more in diameter. Even if finger or other object 12 mm in diameter penetrates, it will not reach a hazardous part.
3		Protects against penetration of any solid object, such as a wire, that is 2.5 mm or more in diameter.
4		Protects against penetration of any solid object, such as a wire, that is 1 mm or more in diameter.
5		Protects against penetration of dust of a quantity that may cause malfunction or obstruct the safe operation of the product.
6		Protects against penetration of all dust.

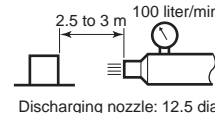
(B) Second Digit: Degree of Protection Against Water

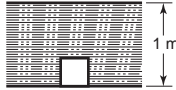
Degree	Protection	Test method (with pure water)
0	No protection	Not protected against water. No test
1	Protection against water drops 	Protects against vertical drops of water towards the product. Water is dropped vertically towards the product from the test machine for 10 min.
2	Protection against water drop 	Protects against drops of water approaching at a maximum angle of 15° to the left, right, back, and front from vertical towards the product. Water is dropped for 25 min each (i.e., 10 min in total) towards the product inclined 15° to the left, right, back, and front from the test machine.
3	Protection against sprinkled water 	Protects against sprinkled water approaching at a maximum angle of 60° from vertical towards the product. Water is sprinkled for 10 min at a maximum angle of 60° to the left and right from vertical from the test machine.

Degree	Protection		Test method (with pure water)
4	Protection against water spray 	Protects against water spray approaching at any angle towards the product.	Water is sprayed at any angle towards the product for 10 min from the test machine. 
5	Protection against water jet spray 	Protects against water jet spray approaching at any angle towards the product.	Water is jet sprayed at any angle towards the product for 1 min per square meter for at least 3 min in total from the test machine. 
6	Protection against high pressure water jet spray 	Protects against high-pressure water jet spray approaching at any angle towards the product.	Water is jet sprayed at any angle towards the product for 1 min per square meter for at least 3 min in total from the test machine. 
7	Protection against limited immersion in water 	Resists the penetration of water when the product is placed underwater at specified pressure for a specified time.	The product is placed 1 m deep in water (if the product is 850 mm max. in height) for 30 min. 
8 (See note.)	Protection against long-term immersion in water 	Can be used continuously underwater.	The test method is determined by the manufacturer and user.

Note: OMRON Test Method

Usage condition: 10 m or less under water in natural conditions

1. No water ingress after 1 hour under water at 2 atmospheres of pressure.
2. Sensing distance and insulation resistance specifications must be met after 100 repetitions of half hour in 5°C water and half hour in 85°C water.

■ Oil Resistance (OMRON in-house standard)

Protection	
Oil-resistant	No adverse affect from oil drops or oil spray approaching from any direction.
Oil-proof	Protects against penetration of oil drops or oil spray approaching from any direction.

Note: This OMRON in-house standard confirms resistance to cutting and other oils. It is equivalent to the former JEM standard.

MEMO

Revision History

AA manual revision code appears as a suffix to the catalog number at the bottom of the front and rear pages.

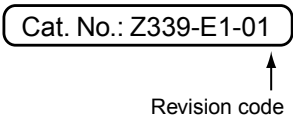

Revision code	Date	Revised contents
01	April 2013	Original production

Terms and Conditions of Sale

1. **Offer; Acceptance.** These terms and conditions (these "**Terms**") are deemed part of all quotes, agreements, purchase orders, acknowledgments, price lists, catalogs, manuals, brochures and other documents, whether electronic or in writing, relating to the sale of products or services (collectively, the "**Products**") by Omron Electronics LLC and its subsidiary companies ("**Omron**"). Omron objects to any terms or conditions proposed in Buyer's purchase order or other documents which are inconsistent with, or in addition to, these Terms.
2. **Prices; Payment Terms.** All prices stated are current, subject to change without notice by Omron. Omron reserves the right to increase or decrease prices on any unshipped portions of outstanding orders. Payments for Products are due net 30 days unless otherwise stated in the invoice.
3. **Discounts.** Cash discounts, if any, will apply only on the net amount of invoices sent to Buyer after deducting transportation charges, taxes and duties, and will be allowed only if (i) the invoice is paid according to Omron's payment terms and (ii) Buyer has no past due amounts.
4. **Interest.** Omron, at its option, may charge Buyer 1-1/2% interest per month or the maximum legal rate, whichever is less, on any balance not paid within the stated terms.
5. **Orders.** Omron will accept no order less than \$200 net billing.
6. **Governmental Approvals.** Buyer shall be responsible for, and shall bear all costs involved in, obtaining any government approvals required for the importation or sale of the Products.
7. **Taxes.** All taxes, duties and other governmental charges (other than general real property and income taxes), including any interest or penalties thereon, imposed directly or indirectly on Omron or required to be collected directly or indirectly by Omron for the manufacture, production, sale, delivery, importation, consumption or use of the Products sold hereunder (including customs duties and sales, excise, use, turnover and license taxes) shall be charged to and remitted by Buyer to Omron.
8. **Financial.** If the financial position of Buyer at any time becomes unsatisfactory to Omron, Omron reserves the right to stop shipments or require satisfactory security or payment in advance. If Buyer fails to make payment or otherwise comply with these Terms or any related agreement, Omron may (without liability and in addition to other remedies) cancel any unshipped portion of Products sold hereunder and stop any Products in transit until Buyer pays all amounts, including amounts payable hereunder, whether or not then due, which are owing to it by Buyer. Buyer shall in any event remain liable for all unpaid accounts.
9. **Cancellation; Etc.** Orders are not subject to rescheduling or cancellation unless Buyer indemnifies Omron against all related costs or expenses.
10. **Force Majeure.** Omron shall not be liable for any delay or failure in delivery resulting from causes beyond its control, including earthquakes, fires, floods, strikes or other labor disputes, shortage of labor or materials, accidents to machinery, acts of sabotage, riots, delay in or lack of transportation or the requirements of any government authority.
11. **Shipping; Delivery.** Unless otherwise expressly agreed in writing by Omron:
 - a. Shipments shall be by a carrier selected by Omron; Omron will not drop ship except in "break down" situations.
 - b. Such carrier shall act as the agent of Buyer and delivery to such carrier shall constitute delivery to Buyer;
 - c. All sales and shipments of Products shall be FOB shipping point (unless otherwise stated in writing by Omron), at which point title and risk of loss shall pass from Omron to Buyer; provided that Omron shall retain a security interest in the Products until the full purchase price is paid;
 - d. Delivery and shipping dates are estimates only; and
 - e. Omron will package Products as it deems proper for protection against normal handling and extra charges apply to special conditions.
12. **Claims.** Any claim by Buyer against Omron for shortage or damage to the Products occurring before delivery to the carrier must be presented in writing to Omron within 30 days of receipt of shipment and include the original transportation bill signed by the carrier noting that the carrier received the Products from Omron in the condition claimed.
13. **Warranties.** (a) **Exclusive Warranty.** Omron's exclusive warranty is that the Products will be free from defects in materials and workmanship for a period of twelve months from the date of sale by Omron (or such other period expressed in writing by Omron). Omron disclaims all other warranties, express or implied. (b) **Limitations.** OMRON MAKES NO WARRANTY OR REPRESENTATION, EXPRESS OR IMPLIED, ABOUT NON-INFRINGEMENT, MERCHANTABILITY OR FITNESS FOR A PARTICULAR PURPOSE OF THE PRODUCTS. BUYER ACKNOWLEDGES THAT IT ALONE HAS DETERMINED THAT THE PRODUCTS WILL SUITABLY MEET THE REQUIREMENTS OF THEIR INTENDED USE. Omron further disclaims all warranties and responsibility of any type for claims or expenses based on infringement by the Products or otherwise of any intellectual property right. (c) **Buyer Remedy.** Omron's sole obligation hereunder shall be, at Omron's election, to (i) replace (in the form originally shipped with Buyer responsible for labor charges for removal or replacement thereof) the non-complying Product, (ii) repair the non-complying Product, or (iii) repay or credit Buyer an amount equal to the purchase price of the non-complying Product; provided that in no event shall Omron be responsible for warranty, repair, indemnity or any other claims or expenses regarding the Products unless Omron's analysis confirms that the Products were properly handled, stored, installed and maintained and not subject to contamination, abuse, misuse or inappropriate modification. Return of any Products by Buyer must be approved in writing by Omron before shipment. Omron Companies shall not be liable for the suitability or unsuitability or the results from the use of Products in combination with any electrical or electronic components, circuits, system assemblies or any other materials or substances or environments. Any advice, recommendations or information given orally or in writing, are not to be construed as an amendment or addition to the above warranty. See <http://www.omron247.com> or contact your Omron representative for published information.
14. **Limitation on Liability; Etc.** OMRON COMPANIES SHALL NOT BE LIABLE FOR SPECIAL, INDIRECT, INCIDENTAL, OR CONSEQUENTIAL DAMAGES, LOSS OF PROFITS OR PRODUCTION OR COMMERCIAL LOSS IN ANY WAY CONNECTED WITH THE PRODUCTS, WHETHER SUCH CLAIM IS BASED IN CONTRACT, WARRANTY, NEGLIGENCE OR STRICT LIABILITY. Further, in no event shall liability of Omron Companies exceed the individual price of the Product on which liability is asserted.
15. **Indemnities.** Buyer shall indemnify and hold harmless Omron Companies and their employees from and against all liabilities, losses, claims, costs and expenses (including attorney's fees and expenses) related to any claim, investigation, litigation or proceeding (whether or not Omron is a party) which arises or is alleged to arise from Buyer's acts or omissions under these Terms or in any way with respect to the Products. Without limiting the foregoing, Buyer (at its own expense) shall indemnify and hold harmless Omron and defend or settle any action brought against such Companies to the extent based on a claim that any Product made to Buyer specifications infringed intellectual property rights of another party.
16. **Property; Confidentiality.** Any intellectual property in the Products is the exclusive property of Omron Companies and Buyer shall not attempt to duplicate it in any way without the written permission of Omron. Notwithstanding any charges to Buyer for engineering or tooling, all engineering and tooling shall remain the exclusive property of Omron. All information and materials supplied by Omron to Buyer relating to the Products are confidential and proprietary, and Buyer shall limit distribution thereof to its trusted employees and strictly prevent disclosure to any third party.
17. **Export Controls.** Buyer shall comply with all applicable laws, regulations and licenses regarding (i) export of products or information; (ii) sale of products to "forbidden" or other proscribed persons; and (iii) disclosure to non-citizens of regulated technology or information.
18. **Miscellaneous.** (a) **Waiver.** No failure or delay by Omron in exercising any right and no course of dealing between Buyer and Omron shall operate as a waiver of rights by Omron. (b) **Assignment.** Buyer may not assign its rights hereunder without Omron's written consent. (c) **Law.** These Terms are governed by the law of the jurisdiction of the home office of the Omron company from which Buyer is purchasing the Products (without regard to conflict of law principles). (d) **Amendment.** These Terms constitute the entire agreement between Buyer and Omron relating to the Products, and no provision may be changed or waived unless in writing signed by the parties. (e) **Severability.** If any provision hereof is rendered ineffective or invalid, such provision shall not invalidate any other provision. (f) **Setoff.** Buyer shall have no right to set off any amounts against the amount owing in respect of this invoice. (g) **Definitions.** As used herein, "including" means "including without limitation"; and "Omron Companies" (or similar words) mean Omron Corporation and any direct or indirect subsidiary or affiliate thereof.

Certain Precautions on Specifications and Use

1. **Suitability of Use.** Omron Companies shall not be responsible for conformity with any standards, codes or regulations which apply to the combination of the Product in the Buyer's application or use of the Product. At Buyer's request, Omron will provide applicable third party certification documents identifying ratings and limitations of use which apply to the Product. This information by itself is not sufficient for a complete determination of the suitability of the Product in combination with the end product, machine, system, or other application or use. Buyer shall be solely responsible for determining appropriateness of the particular Product with respect to Buyer's application, product or system. Buyer shall take application responsibility in all cases but the following is a non-exhaustive list of applications for which particular attention must be given: (i) Outdoor use, uses involving potential chemical contamination or electrical interference, or conditions or uses not described in this document. (ii) Use in consumer products or any use in significant quantities. (iii) Energy control systems, combustion systems, railroad systems, aviation systems, medical equipment, amusement machines, vehicles, safety equipment, and installations subject to separate industry or government regulations. (iv) Systems, machines and equipment that could present a risk to life or property. Please know and observe all prohibitions of use applicable to this Product. NEVER USE THE PRODUCT FOR AN APPLICATION INVOLVING SERIOUS RISK TO LIFE OR PROPERTY OR IN LARGE QUANTITIES WITHOUT ENSURING THAT THE SYSTEM AS A WHOLE HAS BEEN DESIGNED TO ADDRESS THE RISKS, AND THAT THE OMRON'S PRODUCT IS PROPERLY RATED AND INSTALLED FOR THE INTENDED USE WITHIN THE OVERALL EQUIPMENT OR SYSTEM.
2. **Programmable Products.** Omron Companies shall not be responsible for the user's programming of a programmable Product, or any consequence thereof.
3. **Performance Data.** Data presented in Omron Company websites, catalogs and other materials is provided as a guide for the user in determining suitability and does not constitute a warranty. It may represent the result of Omron's test conditions, and the user must correlate it to actual application requirements. Actual performance is subject to the Omron's Warranty and Limitations of Liability.
4. **Change in Specifications.** Product specifications and accessories may be changed at any time based on improvements and other reasons. It is our practice to change part numbers when published ratings or features are changed, or when significant construction changes are made. However, some specifications of the Product may be changed without any notice. When in doubt, special part numbers may be assigned to fix or establish key specifications for your application. Please consult with your Omron's representative at any time to confirm actual specifications of purchased Product.
5. **Errors and Omissions.** Information presented by Omron Companies has been checked and is believed to be accurate; however, no responsibility is assumed for clerical, typographical or proofreading errors or omissions.

OMRON INDUSTRIAL AUTOMATION • THE AMERICAS HEADQUARTERS

Schaumburg, IL USA • 847.843.7900 • 800.556.6766 • www.omron247.com

OMRON CANADA, INC. • HEAD OFFICE

Toronto, ON, Canada • 416.286.6465 • 866.986.6766 • www.omron247.com

OMRON ELECTRONICS DE MEXICO • HEAD OFFICE

México DF • 52.55.59.01.43.00 • 001.800.556.6766 • mela@omron.com

OMRON ELECTRONICS DE MEXICO • SALES OFFICE

Apodaca, N.L. • 52.81.11.56.99.20 • 001.800.556.6766 • mela@omron.com

OMRON ELETRÔNICA DO BRASIL LTDA • HEAD OFFICE

São Paulo, SP, Brasil • 55.11.2101.6300 • www.omron.com.br

OMRON ARGENTINA • SALES OFFICE

Cono Sur • 54.11.4783.5300

OMRON CHILE • SALES OFFICE

Santiago • 56.9.9917.3920

OTHER OMRON LATIN AMERICA SALES

54.11.4783.5300

OMRON EUROPE B.V. • Wegalaan 67-69, NL-2132 JD, Hoofddorp, The Netherlands. • Tel: +31 (0) 23 568 13 00

Fax: +31 (0) 23 568 13 88 • www.industrial.omron.eu