

SP5000X Series - Display Module

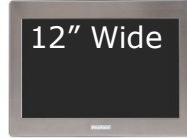

SP-5790WA
Model: PFXSP5790WAD
Model: PFXSP5790WADF0H
(Harsh environment model)



SP-5690WA
Model: PFXSP5690WAD
Model: PFXSP5690WADF0H
(Harsh environment model)



SP-5490WA
Model: PFXSP5490WAD
Model: PFXSP5490WADF0H
(Harsh environment model)

SP5000X Series is a combined unit of Display Module and Box Module.

Model Number Configuration

Display Module							(1) Size	(2) Type	(3) Resolution	(4) Touch Panel		(5) Power Supply		(6) Other				
PFXSP5	*	*	*	*	*	*	7	15"	90	eXtreme	W	Wide TFT	A	Analog	D	DC	F0H	Harsh environment model
	(1)	(2)	(3)	(4)	(5)	(6)	6	12"										
							4	7"										

×

Box Module				(7) Module Type	(8) Class	(9) Other		
PFXSP5	B	*	*	*	*	*		
	(7)	(8)	(9)	B	Box	90	eXtreme	F0H

■ Display Specifications

	SP-5790WA	SP-5690WA	SP-5490WA
Display Type	TFT Color LCD (High-brightness)		
Display Size	15.6" wide	12.1" wide	7" wide
Resolution	1,366 x 768 pixels (FWXGA)	1,280 x 800 pixels (WXGA)	800 x 480 pixels (WVGA)
Effective Display Area	344.2 x 193.5 mm [13.55 x 7.62 in]	261.1 x 163.2 mm [10.28 x 6.43 in]	152.4 x 91.4 mm [6.00 x 3.60 in]
Display Colors	262,144 colors		
Backlight	White LED (Not user replaceable. When replacement is required, contact customer support.)		
Backlight Service Life	50,000 hrs. or more (each in continuous operation at 25 °C [77 °F] before backlight brightness decreases to 50%)		
Brightness Control	0 to 100 (Adjusted with touch panel or software)		
Brightness	1000 cd/m ² (typ.)		
Touch panel type	Analog resistive		
Touch panel resolution	1,024 x 1,024		
Touch panel lifetime	1,000,000 times or more		

■ Electrical Specifications

	SP-5790WA	SP-5690WA	SP-5490WA	
Rated Input Voltage	12 to 24 Vdc			
Input Voltage Limits	10.8 to 28.8 Vdc			
Voltage Drop	12 Vdc: 1.25 ms or less 24 Vdc: 5 ms or less			
Power Consumption *1	Max	48 W	37 W	29 W
	When power is not supplied to external devices	34 W or less	23 W or less	17.5 W or less
	When screen turns off the backlight (Standby Mode)	12.5 W or less		
	When screen backlight 20%	19 W or less	16 W or less	15 W or less
In-Rush Current	30 A or less			
Noise Immunity	Noise voltage: 1,000 Vp-p, Pulse duration: 1 μs, Rise time: 1 ns, (via noise simulator)			
Dielectric Strength	1,000 Vac for 1 minute (between power terminal and FG terminal), leakage current: 20 mA or less			
Insulation resistance	500 Vdc, 10 MΩ or more (between power terminal and FG terminal)			

*1 The power consumption is the sum of the power consumption of Box Module and Display Module.

SP5000X Series - Display Module

Environmental Specification

NOTE:

1) Box Module environmental specifications follow those of the connected Display Module.

2) When using any of the options for this product, check the specifications for special conditions or cautions that may apply to this product.

	SP-5790WA	SP-5690WA	SP-5490WA
Ambient air temperature*1	-20 to 60 °C (-4 to 140 °F) When installing and wiring: -5 to 60 °C (23 to 140 °F)	-30 to 70 °C (-22 to 158 °F) When installing and wiring: -5 to 70 °C (23 to 158 °F)	-30 to 65 °C (-22 to 149 °F) When installing and wiring: -5 to 65 °C (23 to 149 °F)
Storage temperature*1	-20 to 60 °C [-4 to 140 °F] -30 to 70 °C [-22 to 158 °F]		
Ambient humidity	10 to 90 % RH (Wet bulb temperature: 39 °C [102.2 °F] max. - no condensation)		
Storage humidity	10 to 90 % RH (Wet bulb temperature : 39 °C [102.2 °F] max. - no condensation)		
Dust	0.1 mg/m ³ (10 ⁻⁷ oz/ft ³) or less (non-conductive levels)		
Pollution degree	3 for front face, 2 for other sides		
Corrosive gases	Free of corrosive gases Harsh environment model (Model numbers ending with "F0H") : IEC/EN 60721-3-3 Class 3C3 *2		
Atmospheric pressure (operating altitude)	800 to 1,114 hPa (2,000 m [6,561 ft] or lower)		
UV resistance (front side)	Cutoff: 99% or more (380 nm)		
Vibration resistance*1	IEC 60068-2-6 compliant 5 to 9 Hz Single amplitude 3.5 mm (0.14 in) 9 to 150 Hz Fixed acceleration: 9.8 m/s ² X, Y, Z directions for 10 cycles (approximately 100 minutes) IEC 61373: 1999 (Category 1, Class B) 5≤f≤150 Hz (weight < 500 kg: f1=5 Hz, f2=150 Hz) acceleration: Up and down: 7.90 m/s ² , Right and left: 3.50 m/s ² , Back and forward: 5.50 m/s ² *3	IEC 60068-2-6 compliant 5 to 9 Hz Single amplitude 7 mm (0.28 in) 9 to 150 Hz Fixed acceleration: 19.6 m/s ² X, Y, Z directions for 10 cycles (approximately 100 minutes) IEC 61373: 1999 (Category 1, Class B) 5≤f≤150 Hz (weight < 500 kg: f1=5 Hz, f2=150 Hz) acceleration: Up and down: 7.90 m/s ² , Right and left: 3.50 m/s ² , Back and forward: 5.50 m/s ²	
Shock resistance*1	IEC 60068-2-27 compliant 147 m/s ² , 11 ms, X, Y, Z directions for 3 times	IEC 60068-2-27 compliant 392 m/s ² , 11 ms, X, Y, Z directions for 3 times	
Electronic fast transient/burst immunity	IEC 61000-4-4 2 kV: Power port 1 kV: Signal ports		
Electrostatic discharge immunity	Contact discharge method: 6 kV/Air discharge method: 8 kV(IEC/EN 61000-4-2 Level 3)		

*1 When using the fieldbus unit, environmental specifications follow those of the fieldbus unit.

*2 For use in more severe environments, products with model numbers that end in "F0H" have conformal coating of electronic boards. Test levels are as follows.

Model	Standards	Levels
Products with model numbers that end in "F0H"	IEC/EN 60721-3-3	Flowing mixed gas; class 3C3, 25 ° C (77 ° F), 75% relative humidity, t = 7 days Concentrations (ppm): H2S: 2.5 / Cl2: 0.1 / SO2: 2.0

Apply grease (Nyogel 760G) for corrosion prevention to the following interface points.

Box Module	Display module interface, expansion unit interface, Ethernet interface x 2, USB (Type A) interface x 2, USB (mini-B) interface, system card interface, storage card interface
Display Module	Box module interface

*3 When using <J1939 unit>:

IEC 60068-2-6 compliant

5...9 Hz Single amplitude: 1.75 mm (0.069 in)

9...150 Hz Fixed acceleration: 4.9 m/s², X, Y, Z directions for 10 cycles (approximately 100 minutes)

Structural specifications

	SP-5790WA	SP-5690WA	SP-5490WA
Cooling method	Functional grounding: Grounding resistance of 100 Ω or less, 2 mm ² (AWG 14) or thicker wire, or your country's applicable standard (same for FG and SG terminals)		
Cooling method	Natural air circulation		
Structure*4	IP66F, IP67F, Type 4X (indoor and outdoor use), Type 12, Type 13 *5 * on the front panel when properly installed in an enclosure.		
External dimensions	408 x 264 x 68 mm [16.06 x 10.39 x 2.68 in]	308.5 x 230.5 x 68 mm [12.15 x 9.07 x 2.68 in]	203.6 x 148.6 x 37 mm [8.02 x 5.85 x 1.45 in]
Panel cut-out dimensions	394 x 250 mm [15.51 x 9.84 in]*6 Panel thickness area: 1.6 to 5 mm [0.06 to 0.2 in]*7	295 x 217 mm [11.61 x 8.54 in]*6 Panel thickness area: 1.6...5 mm [0.06...0.2 in]*7	190 x 135 mm [7.48 x 5.31 in]*6 Panel thickness area: 1.6...5 mm [0.06...0.2 in]*7
Weight	4.8 kg (10.6 lb) or less	3.2 kg (7.1 lb) or less	1.3 kg (2.9 lb) or less
Front bezel materials	Aluminum die-cast Stainless steel		

*4 The front face of this product, installed in a solid panel, has been tested using conditions equivalent to the standards shown in the specification. Even though this product's level of resistance is equivalent to these standards, oils that should have no effect on this product can possibly harm this product. This can occur in areas where either vaporized oils are present, or where low viscosity cutting oils are allowed to adhere to this product for long periods of time. If this product's front face protection sheet or cover glass peels off, these conditions can lead to the ingress of oil into this product and separate protection measures are suggested. Also, if non-approved oils are present, they may cause deformation or corrosion of the front panel's cover. Therefore, prior to installing this product, be sure to confirm the type of conditions that will be present in this product's operating environment. If the installation gasket is used for a long period of time, or if this product and its gasket are removed from the panel, the original level of protection cannot be kept. To maintain the original protection level, be sure to replace the installation gasket regularly.

*5 Check the model number and product version (PV) on the product label. If the product version is "PV: 01" and only with one of the following model numbers, the protection level is IP66F. Model number: PFXSP5490WAD, PFXSP5690WAD

*6 For dimensional tolerance, everything +1/-0 mm (+0.04/-0 in) and R in angle are below R3 (R0.12 in).

*7 Even if the installation wall thickness is within the recommended range for the Panel Cut Dimensions, depending on wall's material, size, and installation location of this product and other devices, the installation wall could warp. To prevent warping, the installation surface may need to be strengthened.

SP5000X Series - Display Module

External Dimensions / Panel Cut Dimensions

SP-5790WA

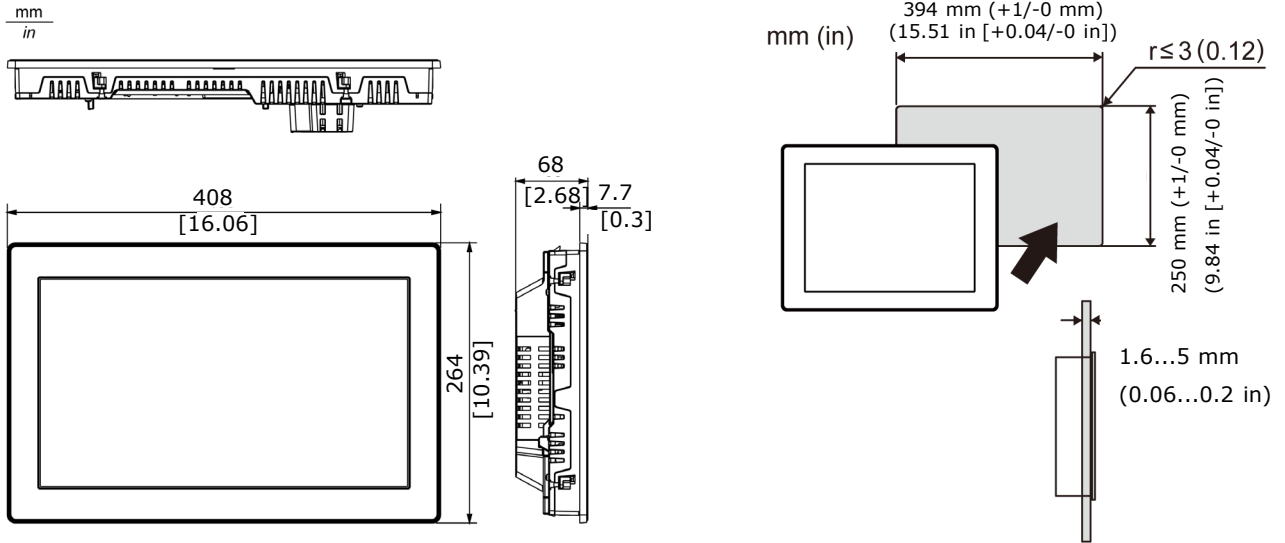

SP-5690WA

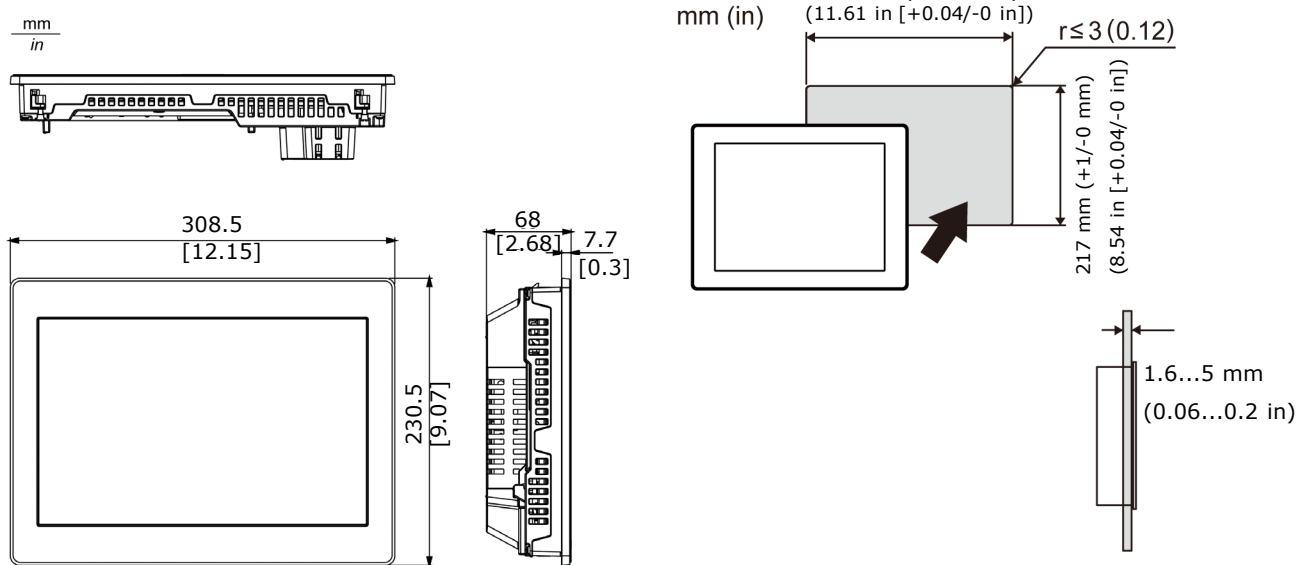

SP-5490WA

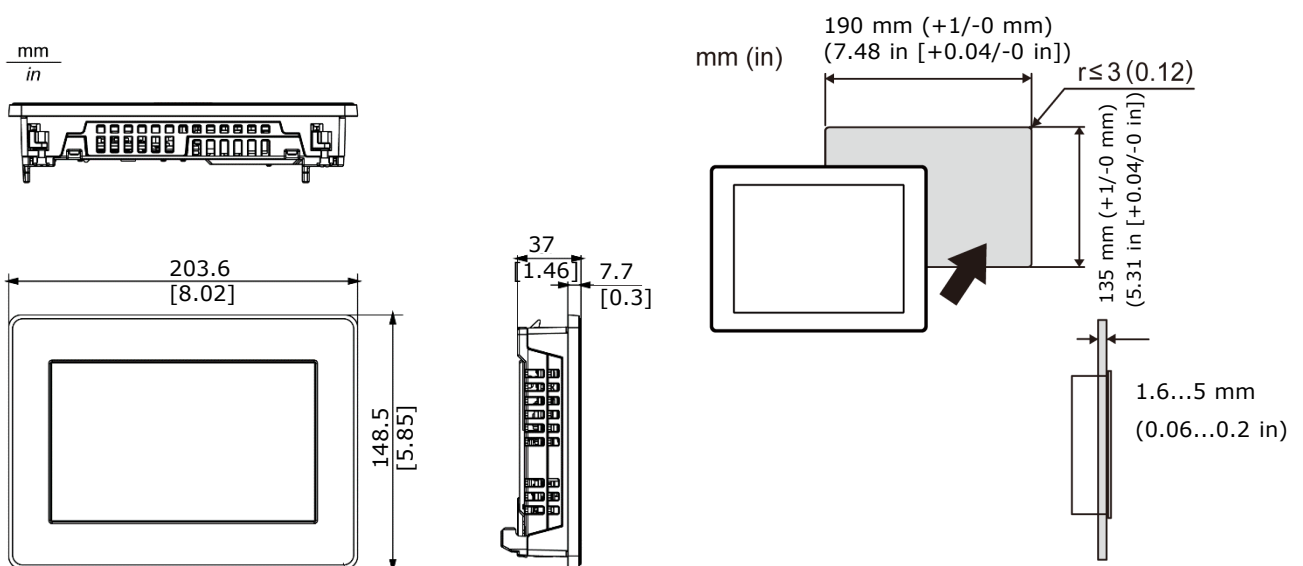

SP5000X Series - BOX Module



SP-5B90

Model: PFXSP5B90
Model: PFXSP5B90F0H (Harsh environment model)

SP5000X Series is a combined unit of Display Module and Box Module.

Model Number Configuration

Display Module							(1) Size	(2) Type	(3) Resolution	(4) Touch Panel		(5) Power Supply		(6) Other				
PFXSP5	*	*	*	*	*	*	7	15"	90	eXtreme	W	Wide TFT	A	Analog	D	DC	F0H	Harsh environment model
	(1)	(2)	(3)	(4)	(5)	(6)	6	12"										
							4	7"										
×																		
Box Module							(7) Module Type	(8) Class	(9) Other									
PFXSP5	B	*	*	*	*	*	B	Box	90	eXtreme	F0H	Harsh environment model						
	(7)	(8)	(9)															

Memory

		Media		SP-5B90
Application memory	Editor : GP-Pro EX	Screen area*1		SD Card
		User font area		64 MB
		Logic program area		8 MB
		Free space		132KB (Equivalent to 15,000 steps)
		Removable system		—
Backup memory	Editor : GP-Pro EX	Screen area		Yes
		Variable area		NVRAM 320 KB
	Battery		NVRAM 64 KB	— *2

*1 Use the screen area when the user font area's capacity is exceeded – for example, when an image font or a picture font is used –.

*2 SP5000X series can retain NVRAM (backup memory) and RTC (clock data) without any batteries. But, when no power is supplied for 100 days or more, it's necessary to additionally mount this option item to retain RTC (clock data).

Interface Specification

SP-5B90	
Serial (COM1)	Asynchronous Transmission: RS-232C / 422 / 485, Data Length: 7 or 8 bits, Stop Bit: 1 or 2 bits, Parity: None, Even or Odd, Data Transmission Speed: 2,400 (1,200) to 115,200 bps, Connector: D-Sub 9 pin (plug)
Serial (COM2)	Asynchronous Transmission: RS-232C / 422 / 485, Data Length: 7 or 8 bits, Stop Bit: 1 or 2 bits, Parity: None, Even or Odd, Data Transmission Speed: 2,400 (1,200) to 115,200 bps, Connector: D-Sub 9 pin (plug)
USB (Type A)	Conforms to USB 2.0 (Type A) x 2 Power supply voltage: 5 Vdc ± 5 % Output Current: 500 mA/port Communication distance: 5 m [16.4 ft.]
USB (mini-B)	Conforms to USB 2.0 (mini-B) x 1, Communication Distance: 5 m [16.4 ft] or less
Ethernet	EEE802.3i / IEEE802.3u / IEEE802.3ab, 10BASE-T / 100BASE-TX / 1000BASE-T, Connector: Modular jack (RJ-45) x 2 *3
SD card	SD Card Slot (System) x 1, SD Card Slot (Storage) x 1
Expansion unit	Fieldbus Unit (J1939 or PROFIBUS or CANopen or FLEX NETWORK) x 1
Sound output	Speaker Output: 300mW (Rated Load: 8Ω, Frequency: 1kHz) (Software Switch), LINE Output: Rated load: 10kΩ or more (Software Switch), Connector: 2-piece terminal block (AUX) x 1
AUX output	Alarm Output or Buzzer Output x 1 Rated Voltage: 24 Vdc, Rated Current: 50 mA or less Connector: 2-piece terminal block (AUX) x 1

*3 For 1000BASE-T communication, use twisted pair Ethernet cables with a rating of category 5e or higher.

NOTE:

1) Box Module environmental specifications follow those of the connected Display Module.

2) When using any of the options for this product, check the specifications for special conditions or cautions that may apply to this product.

SP5000X Series - BOX Module

External Dimensions / Panel Cut Dimensions

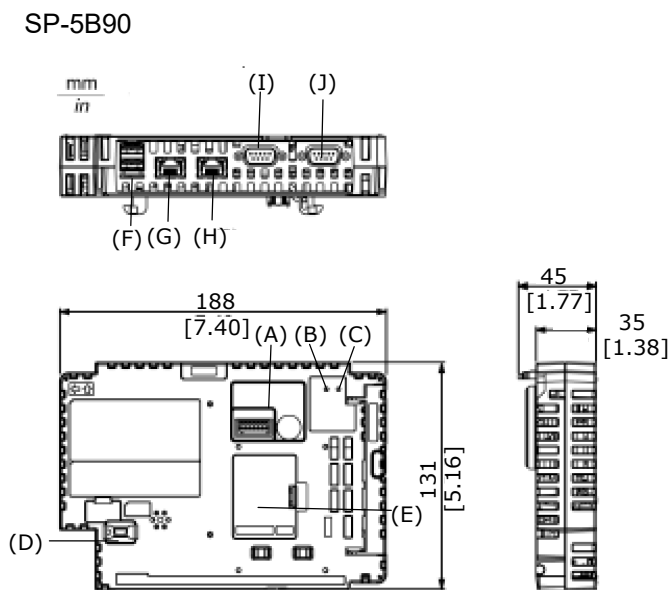

- A : Auxiliary output/ Speaker output interface (AUX)
This interface is alarm output or buzzer output, and sound output.
- B : Status LED
- C : Card access LED
- D : USB(mini-B) interface
- E : Expansion unit interface cover (EXIT)
- F : USB(Type A)interface
- G : Ethernet interface(Ethernet1)
- H : Ethernet interface(Ethernet2)
- I : Serial interface(COM1)
- J : Serial interface(COM2)